



US00D551202S

(12) **United States Design Patent**
Choi

(10) **Patent No.:** **US D551,202 S**

(45) **Date of Patent:** **** Sep. 18, 2007**

(54) **MOBILE PHONE**

(75) Inventor: **Won Seok Choi**, Gyeonggi-do (KR)

(73) Assignee: **LG Electronics Inc.**, Seoul (KR)

(**) Term: **14 Years**

(21) Appl. No.: **29/262,504**

(22) Filed: **Jul. 5, 2006**

(30) **Foreign Application Priority Data**

Jan. 6, 2006 (KR) 30-2006-0000581

(51) **LOC (8) Cl.** **14-03**

(52) **U.S. Cl.** **D14/138**

(58) **Field of Classification Search** D14/137-138,
D14/147-148, 156, 218, 247-248, 341-347,
D14/496; D16/208; D21/329, 331, 333,
D21/517; 348/14.01-14.02; 361/814; 379/
433.01-433.13; 455/556.1-556.2, 575.1,
455/575.3, 575.4, 566, 90.3

See application file for complete search history.

(56) **References Cited**

U.S. PATENT DOCUMENTS

D488,471 S *	4/2004	Yagawa et al.	D14/346
D496,645 S *	9/2004	Yoo et al.	D14/138
D502,160 S *	2/2005	Chen et al.	D14/138
D502,703 S *	3/2005	Tsujimoto et al.	D14/346
D515,528 S *	2/2006	Miyazawa et al.	D14/138
D523,836 S *	6/2006	Park	D14/138
D523,837 S *	6/2006	Lee	D14/138
D528,093 S *	9/2006	Yang et al.	D14/138
D536,325 S *	2/2007	Kim et al.	D14/138
D538,252 S *	3/2007	Joung	D14/138
D538,773 S *	3/2007	Joung	D14/138

2004/0180703 A1* 9/2004 Kim et al. 455/575.1
2005/0245295 A1* 11/2005 Lee et al. 455/575.1

FOREIGN PATENT DOCUMENTS

WO DM/067687 * 3/2006

OTHER PUBLICATIONS

“Nokia 3250”, 3 p including photos, [online], <URL:http://www.gsmarena.com/nokia_3250-1296.php>, announced Sep. 2005, site visited Apr. 12, 2007.*

* cited by examiner

Primary Examiner—Charles A. Rademaker

Assistant Examiner—Carla Jobe Wright

(74) *Attorney, Agent, or Firm*—Birch, Stewart, Kolasch & Birch, LLP

(57) **CLAIM**

The ornamental design for a mobile phone, as shown and described.

DESCRIPTION

FIG. 1 is a perspective view of a mobile phone showing my new design;

FIG. 2 is a front view thereof;

FIG. 3 is a rear view thereof;

FIG. 4 is a left side view thereof;

FIG. 5 is a right side view thereof;

FIG. 6 is a top plan view thereof;

FIG. 7 is a bottom plan view thereof; and,

FIG. 8 is a front view thereof showing the lower portion in a rotated condition.

1 Claim, 7 Drawing Sheets

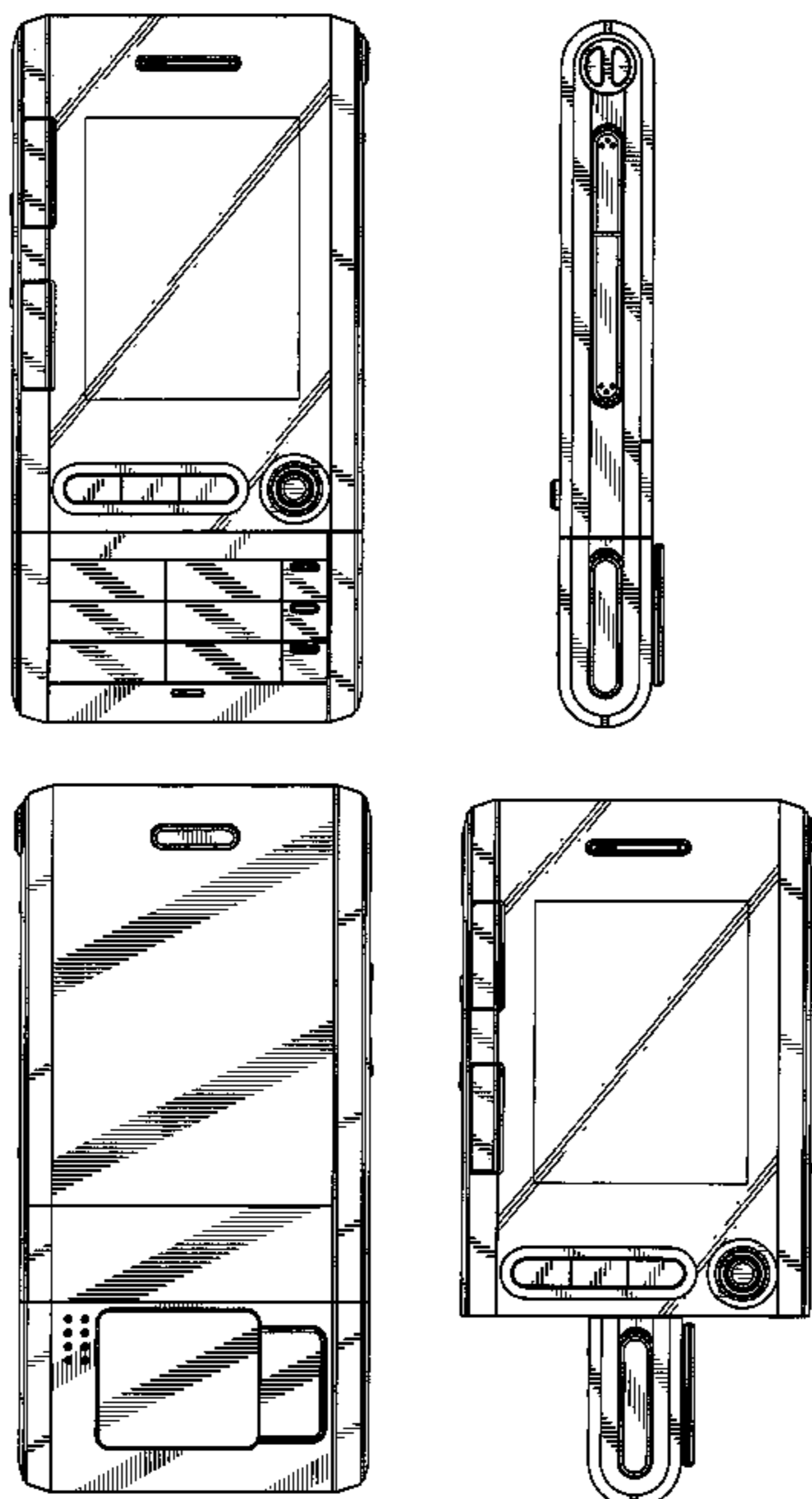

FIG. 1

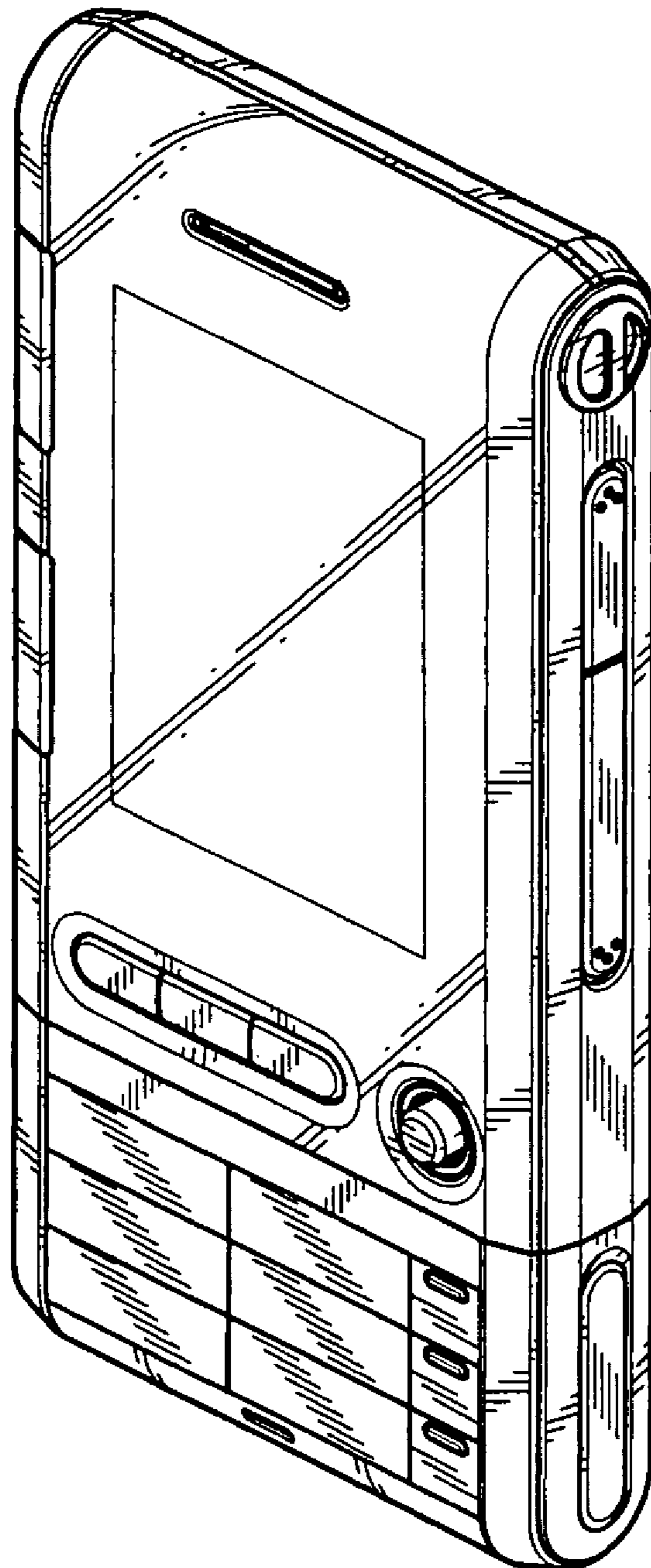

FIG. 2

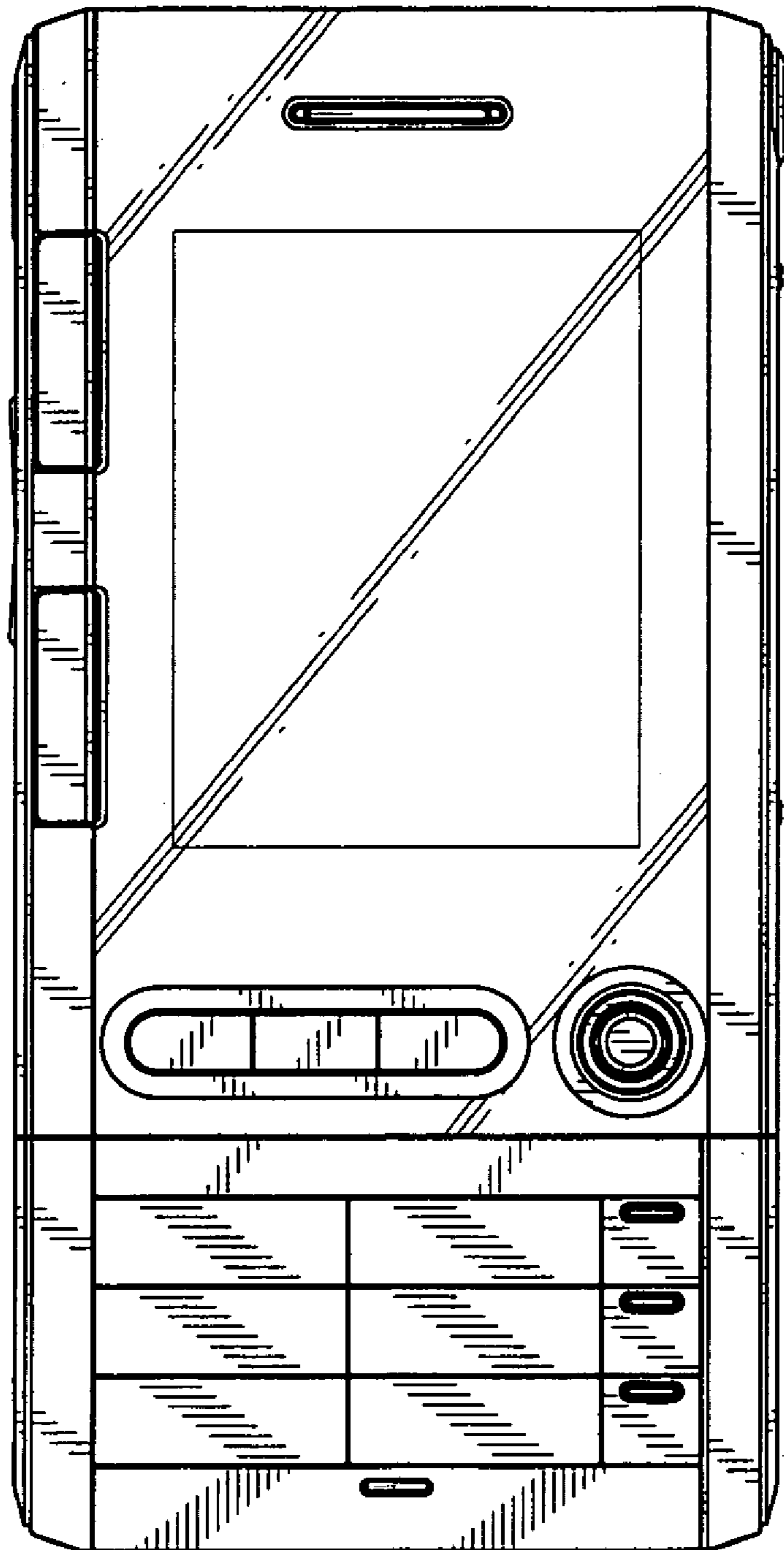

FIG. 3

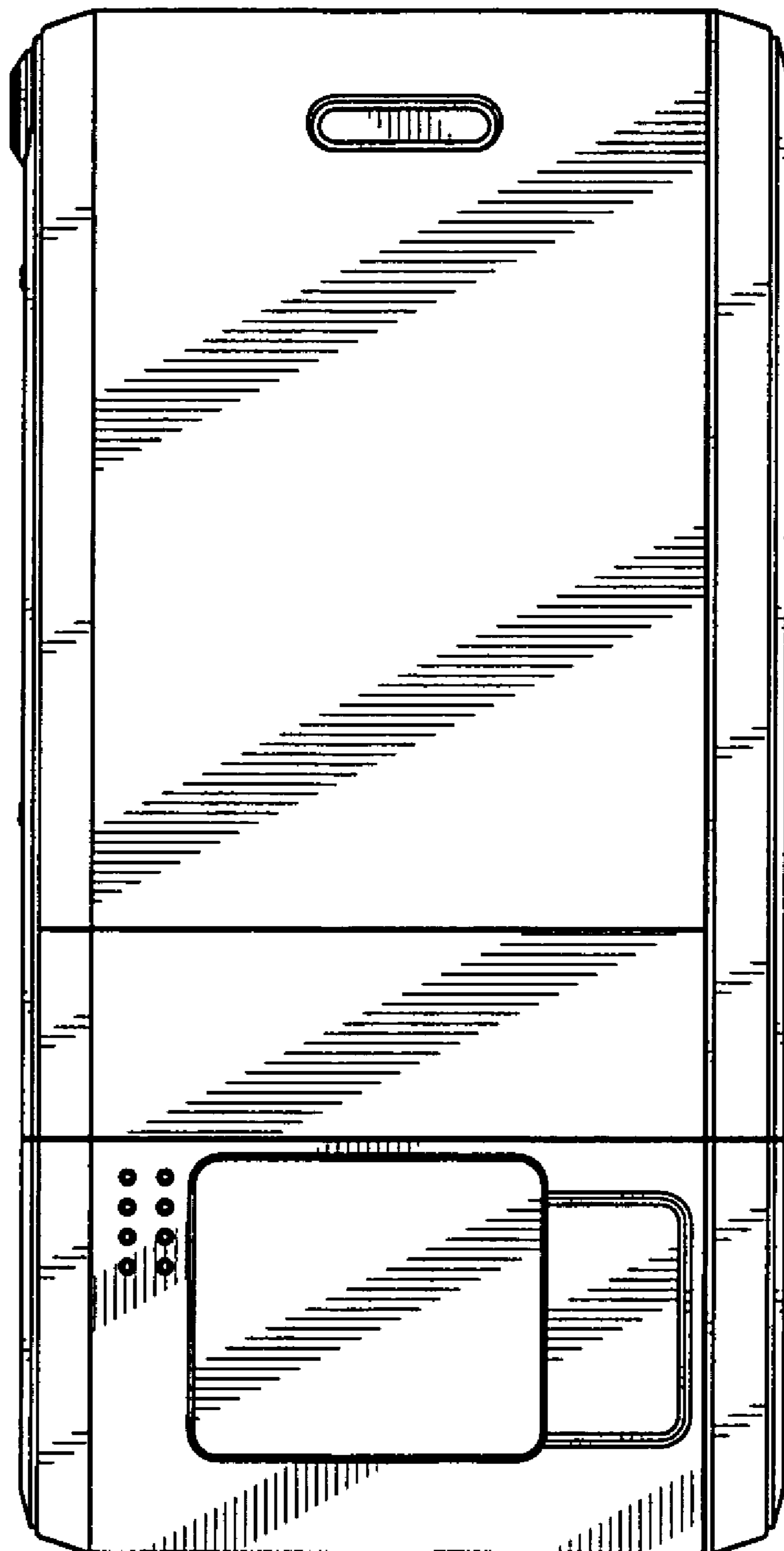

FIG. 4

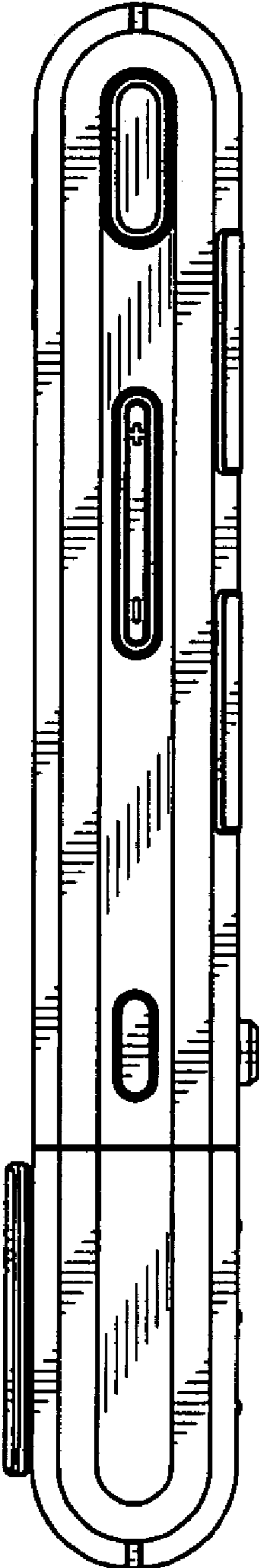

FIG. 5

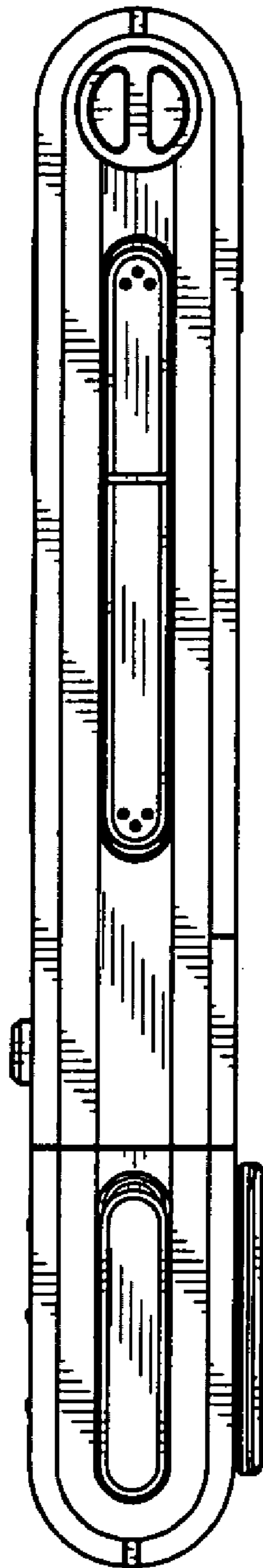

FIG. 6

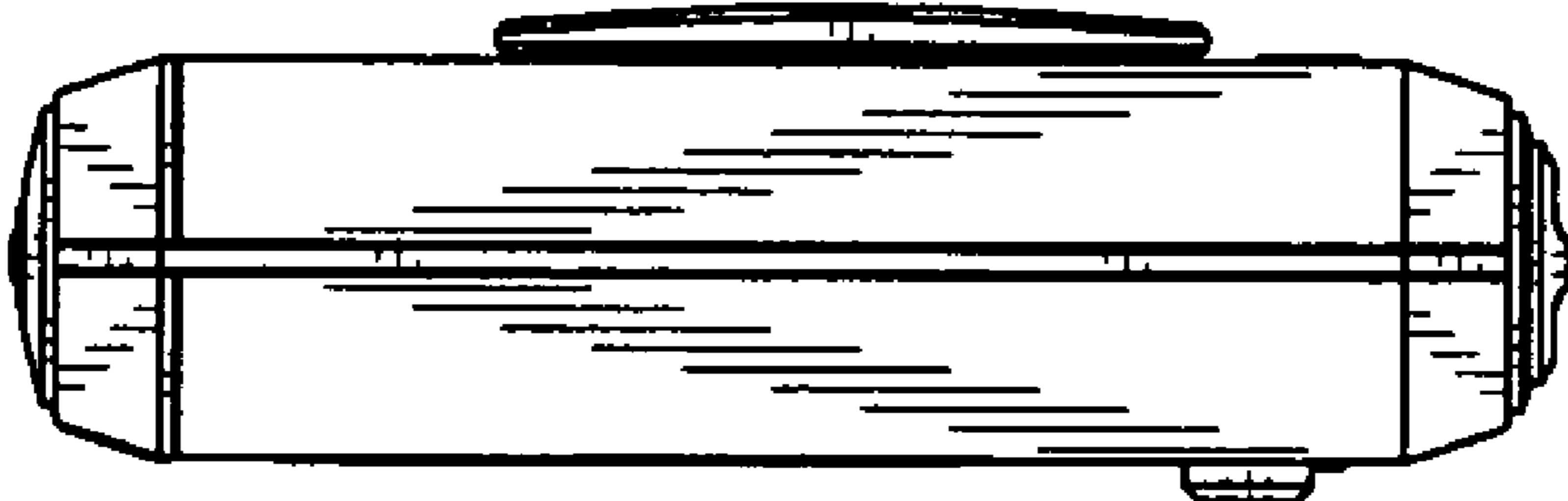

FIG. 7

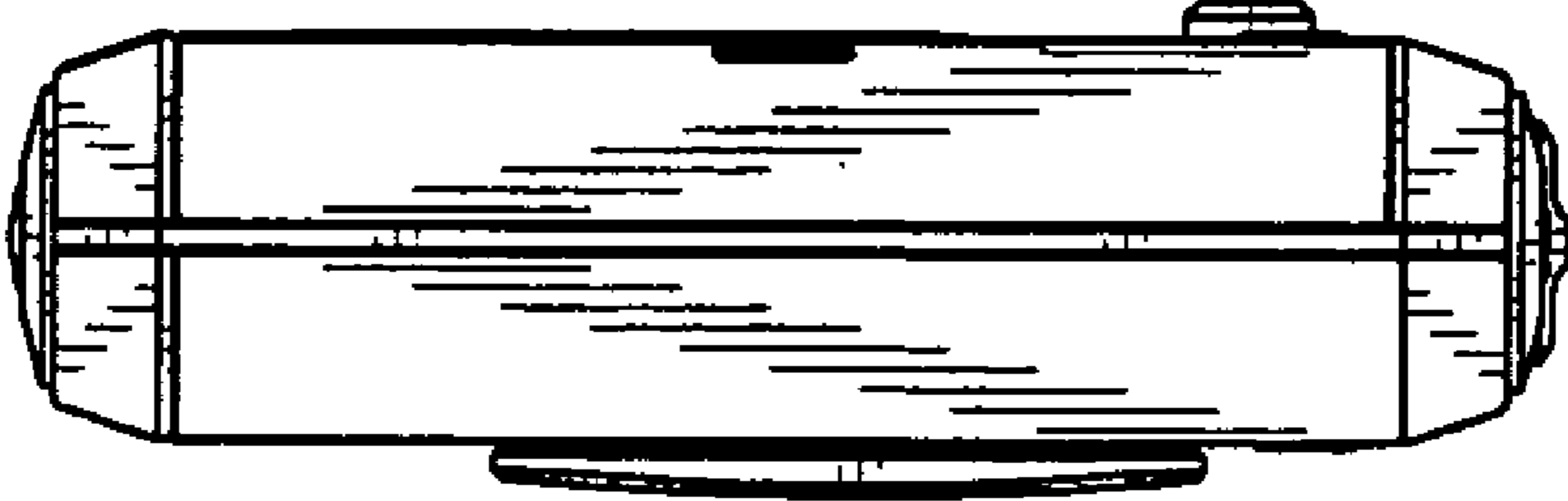

FIG. 8

