



US00D551139S

(12) **United States Design Patent** (10) **Patent No.:** **US D551,139 S**
Barnes et al. (45) **Date of Patent:** **** Sep. 18, 2007**

(54) **SUPPLEMENTAL BRAKING UNIT**

(57) **CLAIM**

(75) Inventors: **Jimmie Barnes**, Emporia, KS (US);
Vicki Sickler, Emporia, KS (US)

The ornamental design for a supplemental braking unit, as shown and described.

(73) Assignee: **Hopkins Manufacturing Corp.**,
Emporia, KS (US)

DESCRIPTION

(**) Term: **14 Years**

(21) Appl. No.: **29/243,369**

(22) Filed: **Nov. 23, 2005**

(51) **LOC (8) Cl.** **12-16**

(52) **U.S. Cl.** **D12/180**

(58) **Field of Classification Search** D12/179-180;
188/21, 22, 73.3, 71.1, 352, 73.31, 73.45;
303/7, 20; 73/132

See application file for complete search history.

(56) **References Cited**

U.S. PATENT DOCUMENTS

1,907,835 A	5/1933	Langbein
2,566,859 A	9/1951	Seeler
2,676,225 A	4/1954	Jubell
2,711,228 A	6/1955	Shank
2,964,965 A	12/1960	Hanson
3,662,593 A	5/1972	Pirrello et al.
3,866,719 A	2/1975	Streutker
3,877,318 A	4/1975	Castoe
3,991,609 A	11/1976	Asmus et al.

(Continued)

OTHER PUBLICATIONS

2004 BrakePro Owner's Manual, Roadmaster, Inc., 12 pages.
3 Digital Photographs of Tekonsha Prodigy Brake Control unit
purchased prior to Nov. 15, 2002.

(Continued)

Primary Examiner—Stacia Cadmus
(74) *Attorney, Agent, or Firm*—Sheridan Ross P.C.

FIG. 1 is a perspective view of a supplemental braking unit showing our new design;

FIG. 2 is a top plan view of the design illustrated in FIG. 1;

FIG. 3 is a front elevation view of the design illustrated in FIG. 1;

FIG. 4 is a left elevation view of the design illustrated in FIG. 1;

FIG. 5 is a rear elevation view of the design illustrated in FIG. 1;

FIG. 6 is a right elevation view of the design illustrated in FIG. 1;

FIG. 7 is a bottom plan view of the design illustrated in FIG. 1;

FIG. 8 is a perspective view of an alternative embodiment of the design illustrated in FIG. 1, the broken lines being for illustrative purposes only and forming no part of the claimed design, and the only difference being the omission of certain external grooves and appendages;

FIG. 9 is a top plan view of the design illustrated in FIG. 8;

FIG. 10 is a front elevation view of the design illustrated in FIG. 8;

FIG. 11 is a left elevation view of the design illustrated in FIG. 8;

FIG. 12 is a rear elevation view of the design illustrated in FIG. 8;

FIG. 13 is a right elevation view of the design illustrated in FIG. 8; and,

FIG. 14 is a bottom plan view of the design illustrated in FIG. 8.

1 Claim, 8 Drawing Sheets

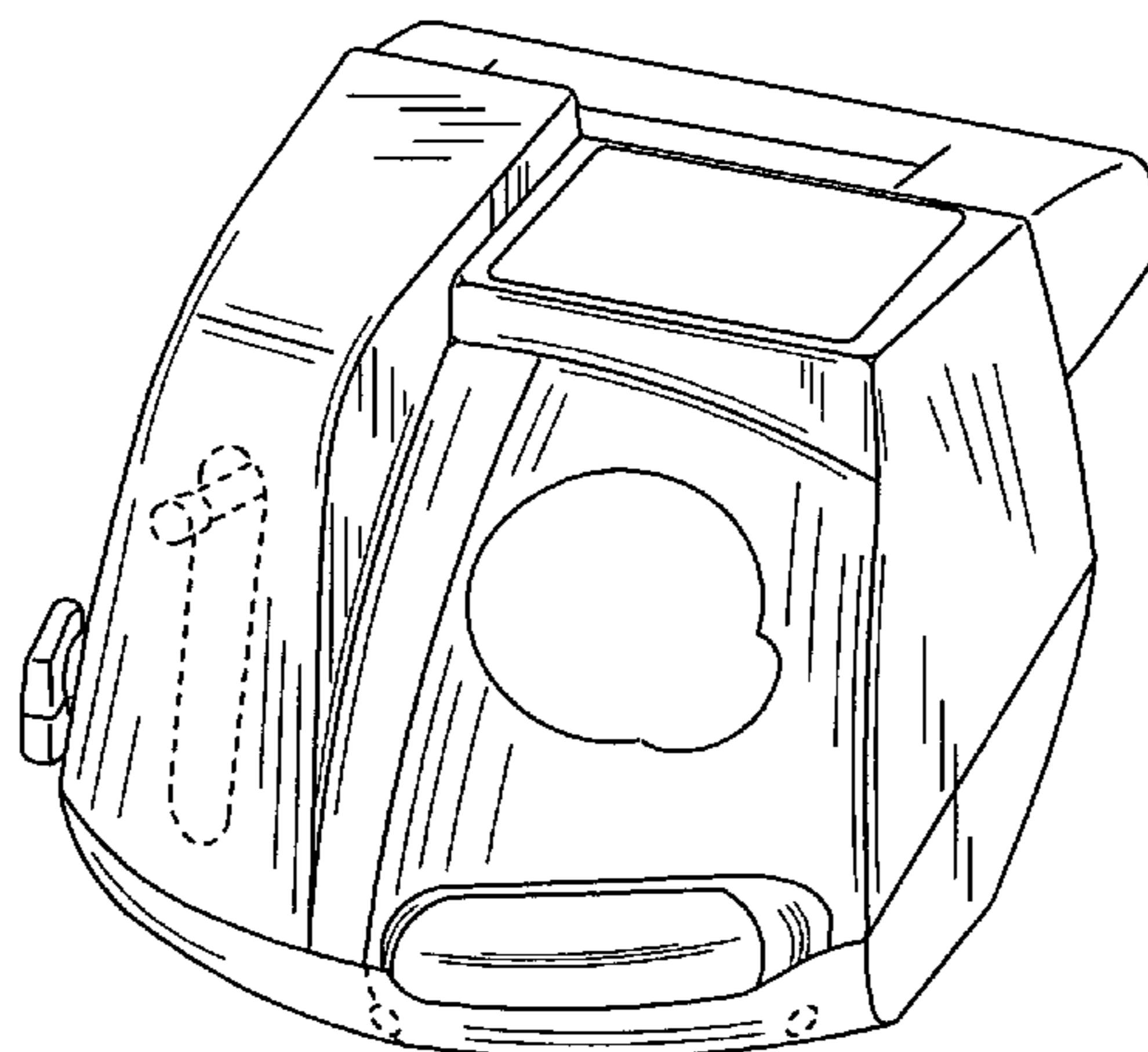

U.S. PATENT DOCUMENTS

4,186,595	A	2/1980	Domitter	
D308,525	S	6/1990	Robbins	
5,012,689	A	5/1991	Smith	
5,031,729	A	7/1991	Wittkop et al.	
5,078,024	A	1/1992	Cicotte et al.	
5,299,668	A	4/1994	Youngers et al.	
5,368,135	A	11/1994	Sallee	
5,411,321	A	5/1995	Harness	
5,460,061	A	10/1995	Redding et al.	
D370,448	S	6/1996	McCoy et al.	
5,911,483	A	6/1999	Overhulser	
5,915,797	A	6/1999	Springer	
5,915,798	A	6/1999	Ford	
5,954,164	A	9/1999	Latham	
D418,098	S	12/1999	Wallace	
6,050,649	A	4/2000	Hensley	
6,095,619	A	8/2000	Granata	
6,126,246	A	10/2000	Decker, Sr. et al.	
6,131,712	A	10/2000	Rhodenizer	
6,158,823	A	12/2000	Sauck	
6,280,004	B1	8/2001	Greaves, Jr.	
D468,243	S	1/2003	Iida	
D477,553	S	7/2003	Brock et al.	
6,626,504	B2	9/2003	Harner et al.	
6,634,466	B1	10/2003	Brock et al.	
6,644,761	B2	11/2003	Schuck	
6,652,042	B2	11/2003	Johnson	
D490,349	S *	5/2004	Brock et al.	D12/180
D498,190	S	11/2004	Brock et al.	
2004/0007913	A1	1/2004	Erwin	
2005/0093366	A1	5/2005	Elstad et al.	
2005/0146212	A1	7/2005	Cannon	
2005/0225169	A1	10/2005	Skinner et al.	

OTHER PUBLICATIONS

Activator Brake Control description as found on Jun. 16, 2000, www.hitchcorner.com, 1 page.
 Busick, Stephen, "Supplemental Braking Systems," Family Motor Coaching, Jul. 2001, pp. 60-75.

Brake Controllers Article, circa Oct. 10, 1999, reprinted from www.rversonline.org, 1 page.
 Digital photographs of a Roadmaster BrakePro braking system unit with fastening device, purchased on Jan. 29, 2004, 5 pages.
 Draw-Tite Activator Manual, date unknown, 9 pages.
 Installation Instructions for the Second Vehicle Kit # 98100 for Brake Master 9000 & 9100, copyright 1999, from <http://www.roadmasterinc.com/pdf/85-1850.pdf>, printed Jun. 25, 2004, 11 pages.
 Master Concepts Inc. Brakebuddy® brochure dated Aug. 2001, 6 pages.
 Master concepts Inc. Brakebuddy® brochure dated Jun. 2003, 6 pages.
 Master Concepts Inc. Brakebuddy® brochure dated Jan. 2002, 6 pages.
 BrakePro Braking System, www.roadmaster-tow-bars.com/Brakepro.htm, printed on May 19, 2004 (product believed to be added to the website after Jun. 23, 2003), 4 pages.
 Tekonsha Prodigy Product, circa 2002, but date uncertain, www.tekonsha.com, 3 pages.
 Unified Tow Brake Brochure, circa 2001, printed from www.usgear.com, 6 pages.
 D-Celerator Unified Tow Brake Manual, date uncertain, printed from www.usgear.com, 9 pages.
 D-Celerator, Unified Tow rake Manual, Aug. 2005, www.usgear.com, 11 pages.
 U.S. Gear Corp. Website, www.usgear.com, D-Celerator Unified Tow Brake product, 5 pages.
 New Even Brake Portable Proportional Braking System, Road Master, Inc. Website, www.roadmasterinc.com/evenbrake.html, Nov. 2005, 3 pages.
 Even Brake Owner's Manual, 24 pages, Oct. 2005.
 BX 88179 Installation Instructions, Blue Ox, Apollo Brake System, 2003, 4 pages.
 Blue Ox Apollo Braking System, www.bludox.com, US/Brakes/apollo.htm, Nov. 2005, 3 pages.
 Brake Buddy Vantage Installation Manual, 2004, 5 pages.
 Brake Buddy Vantage, Break-away Installation Manual, 2004, 2 pages.

* cited by examiner

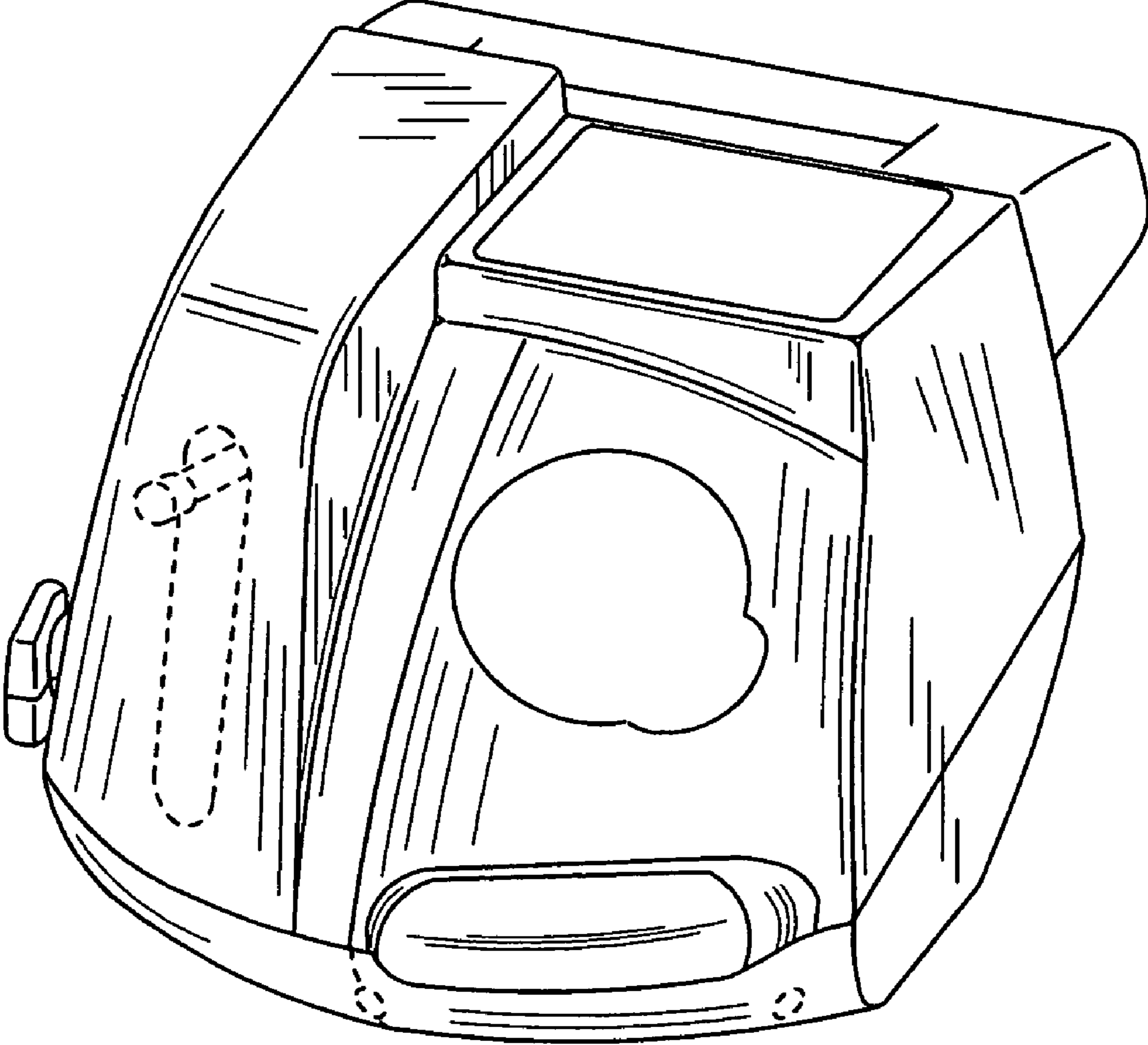

Fig. 1

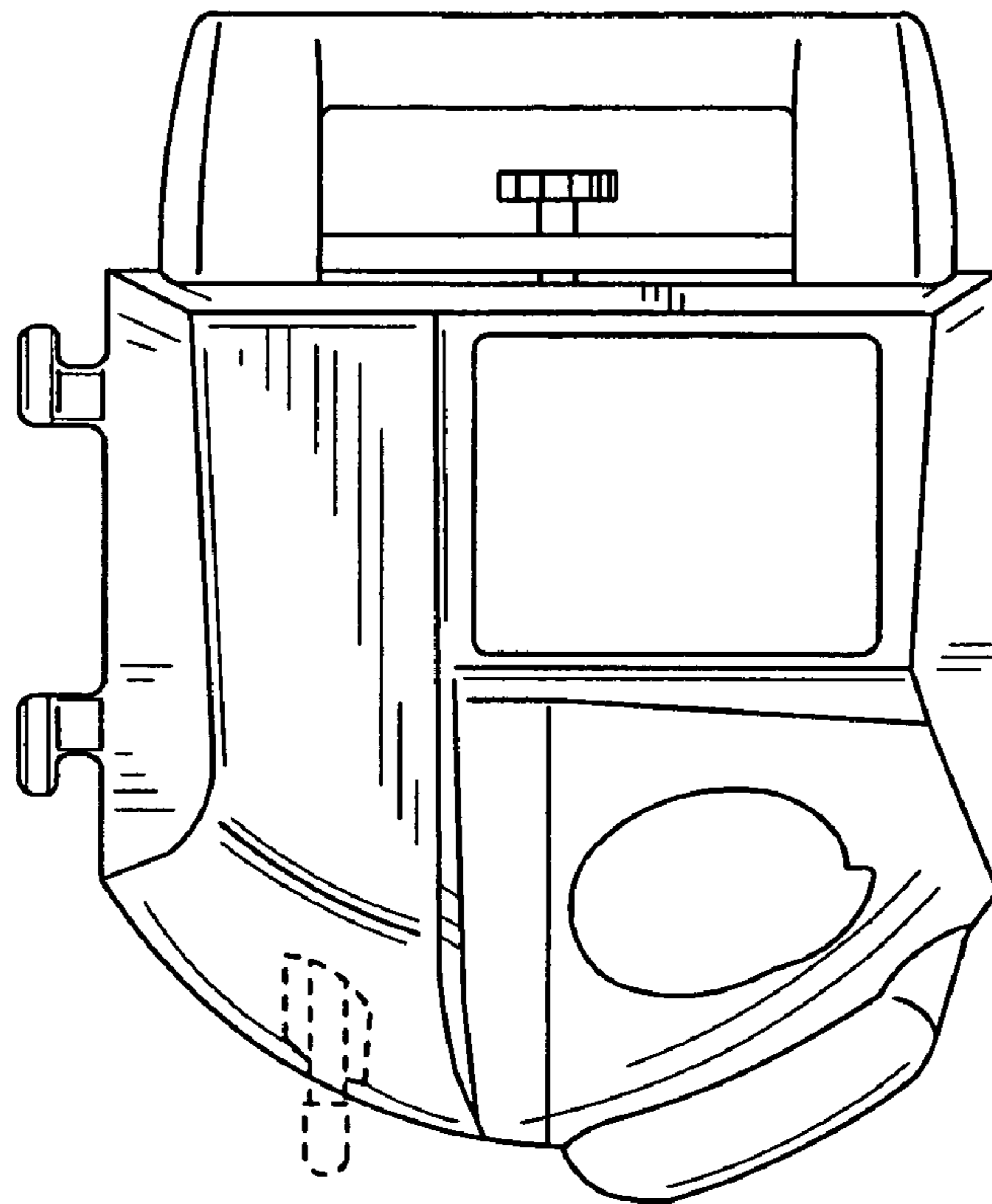

Fig. 2

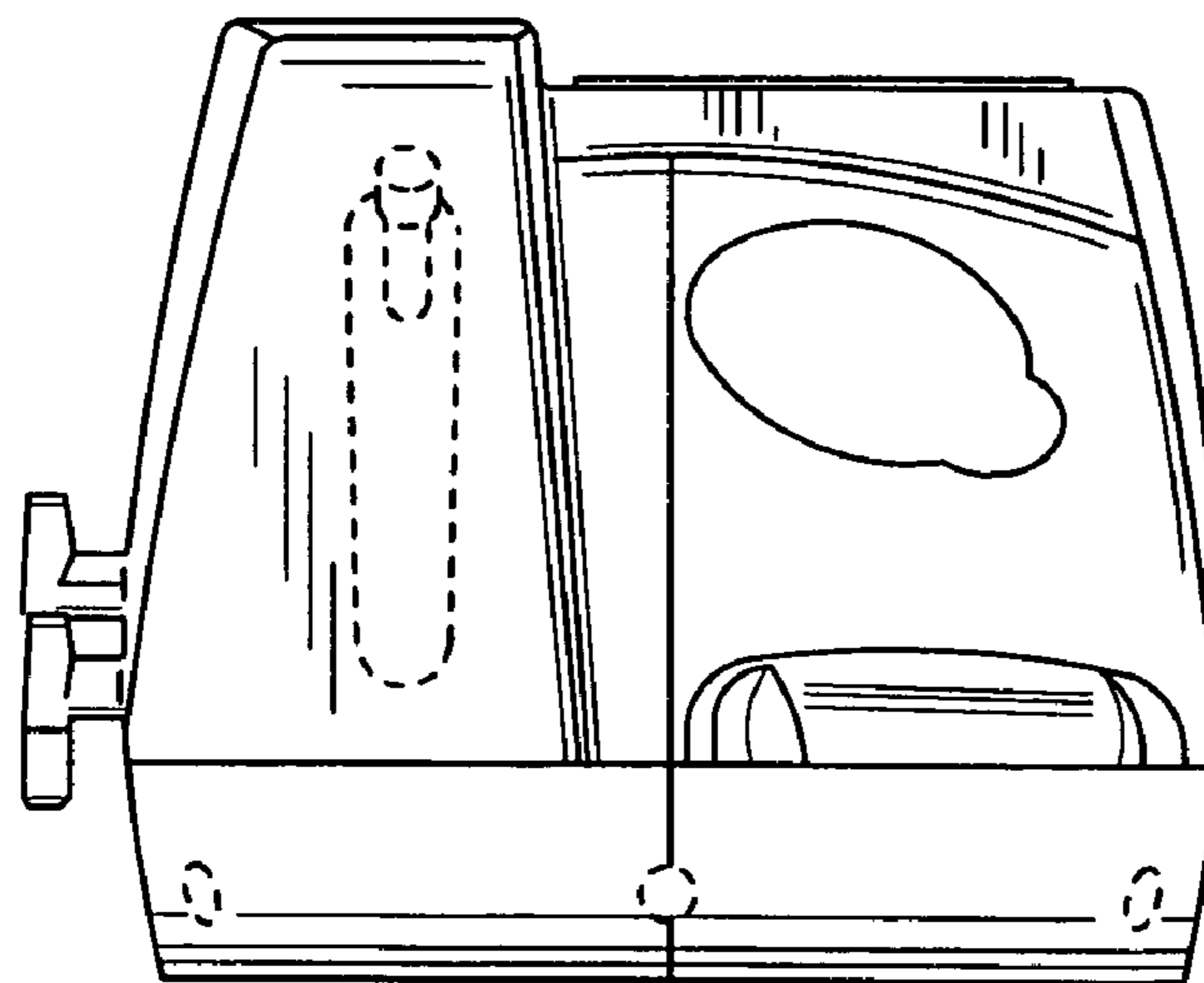

Fig. 3

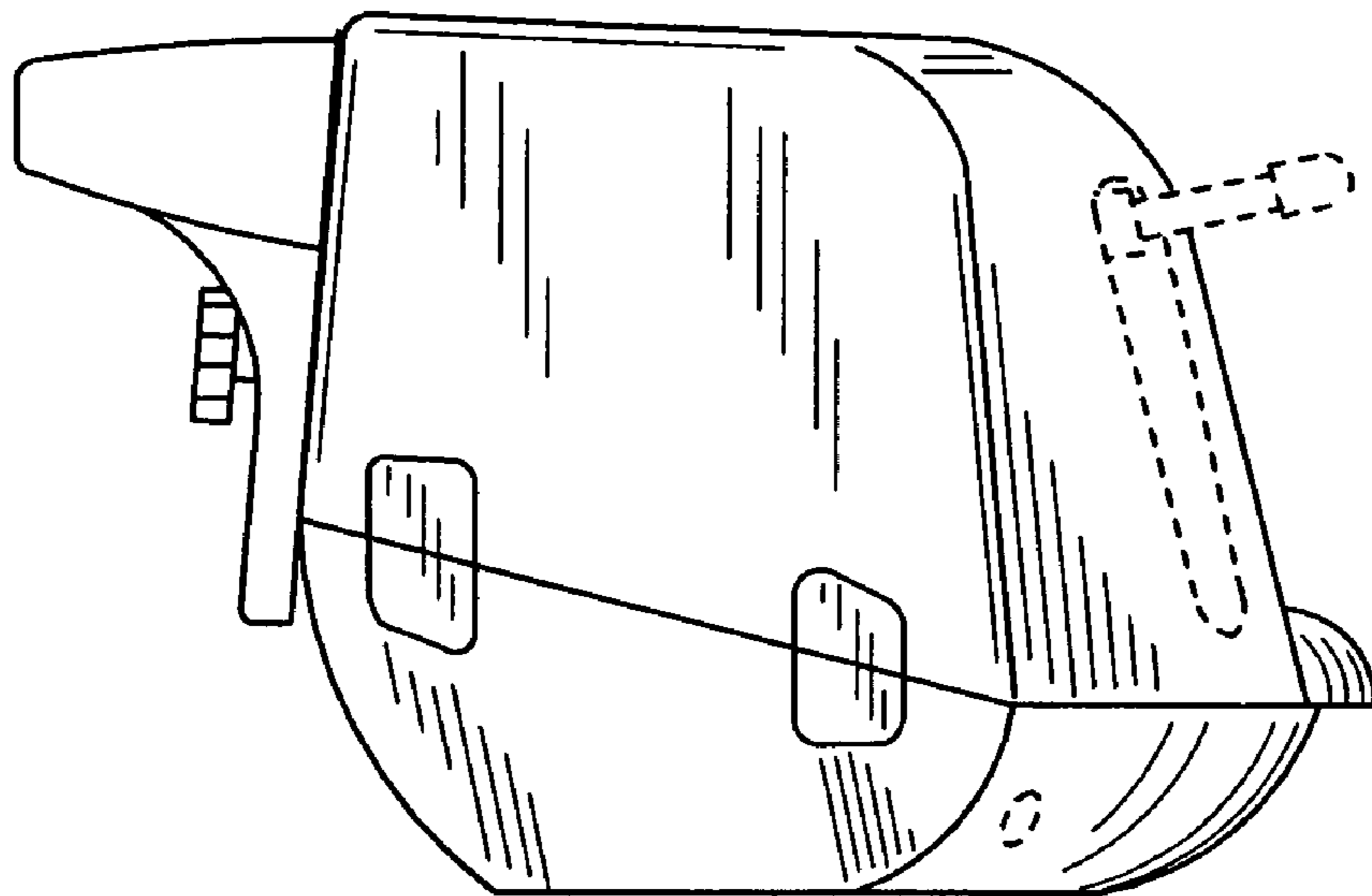

Fig. 4

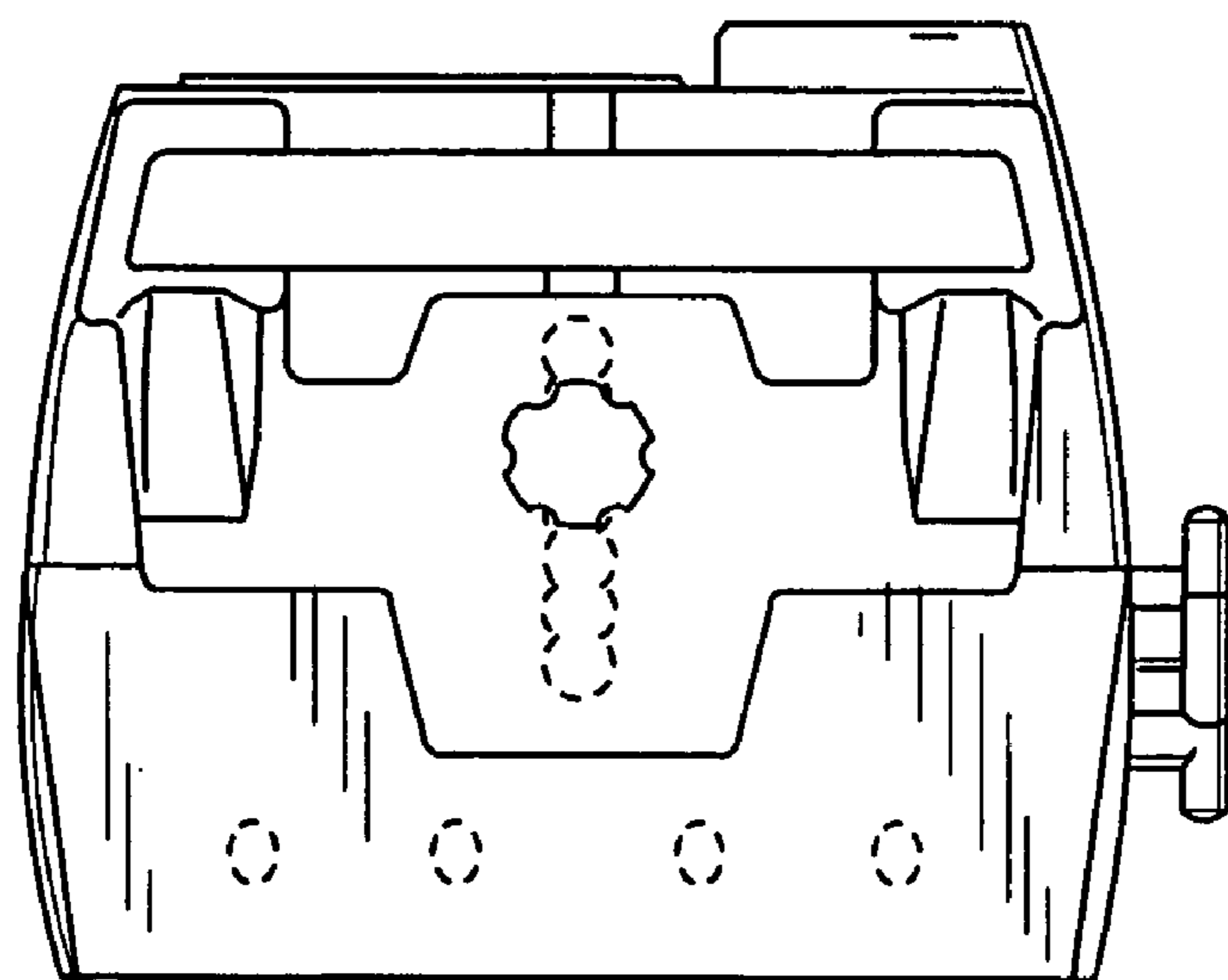

Fig. 5

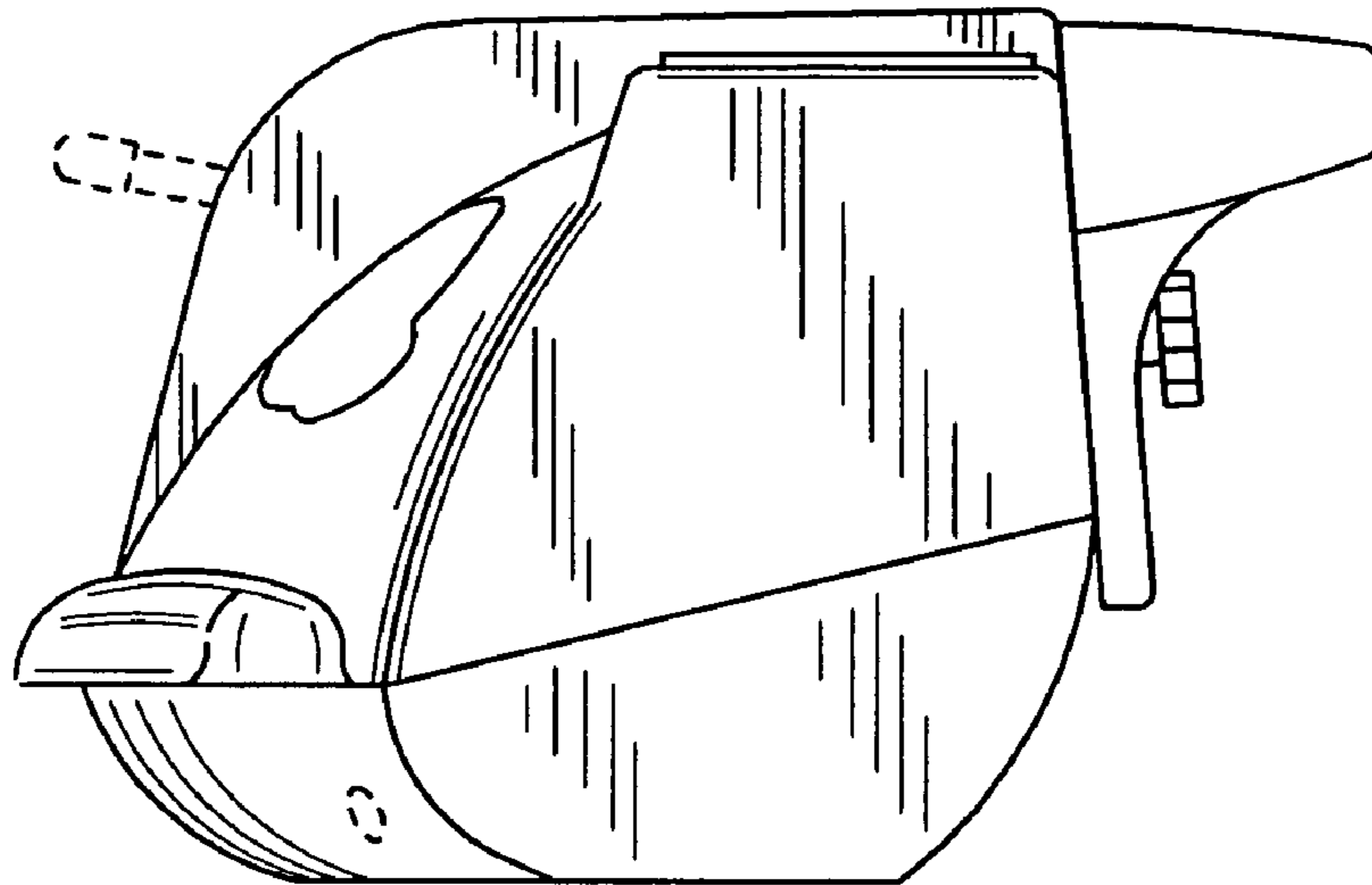

Fig. 6

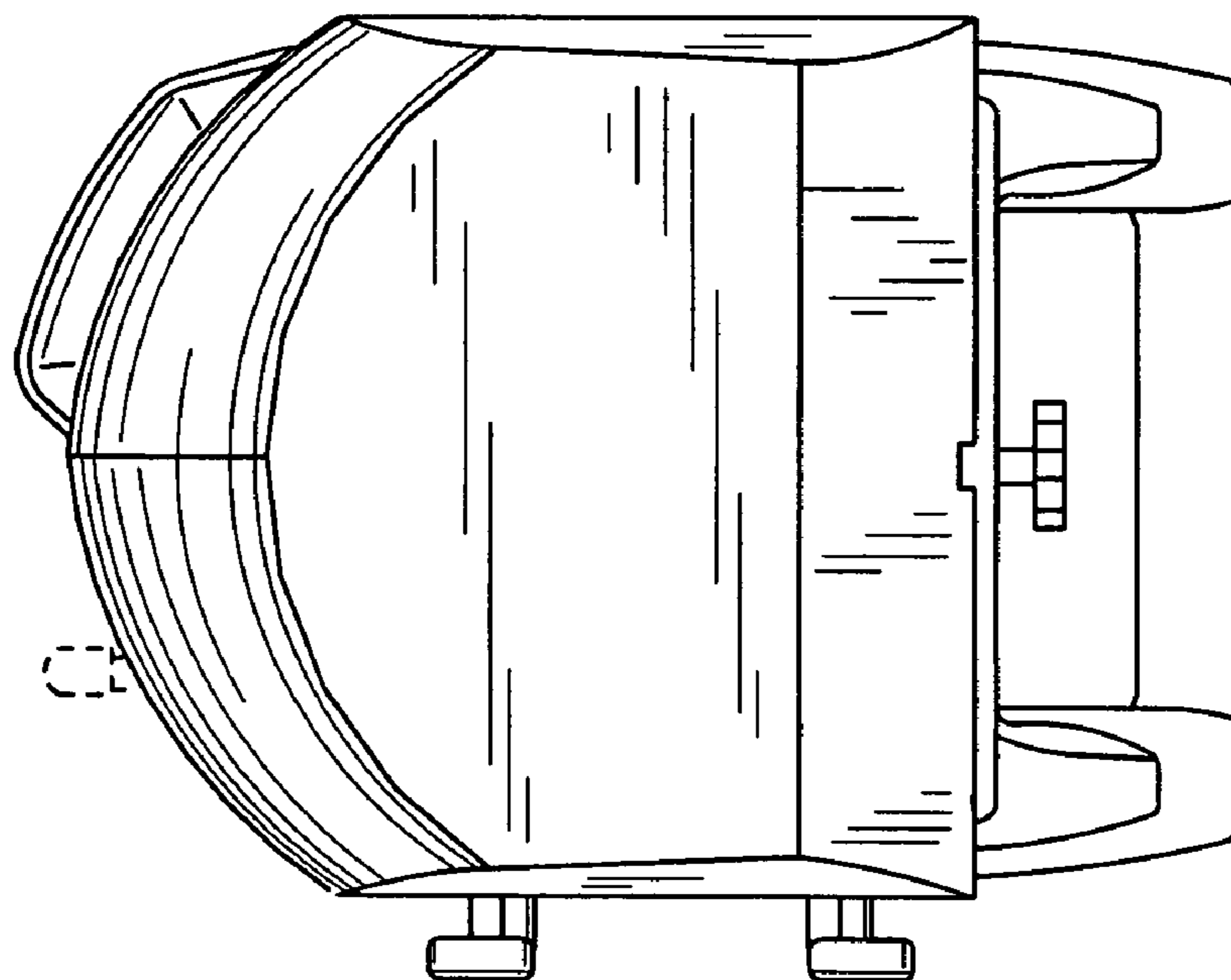

Fig. 7

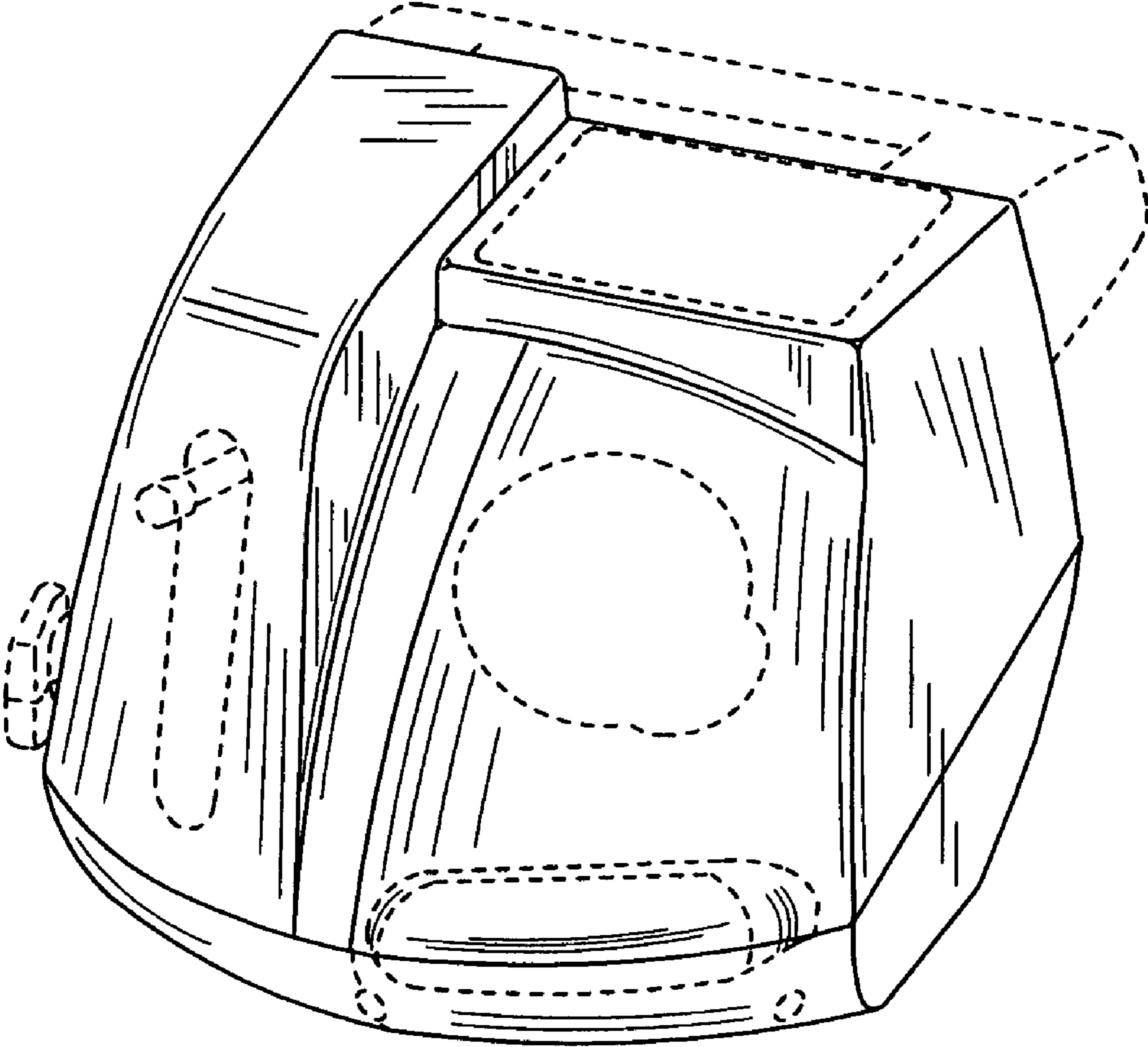

Fig. 8

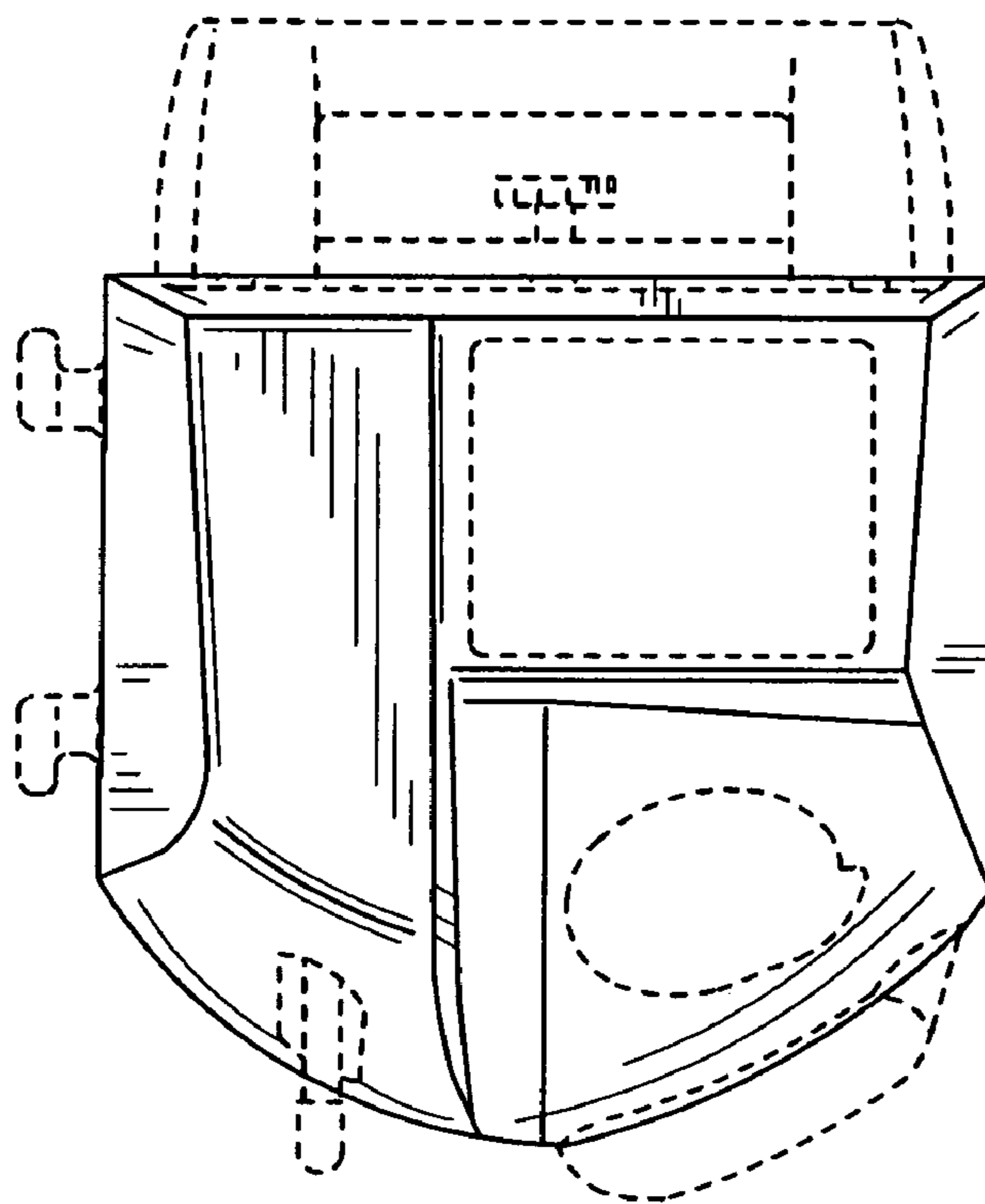

Fig. 9

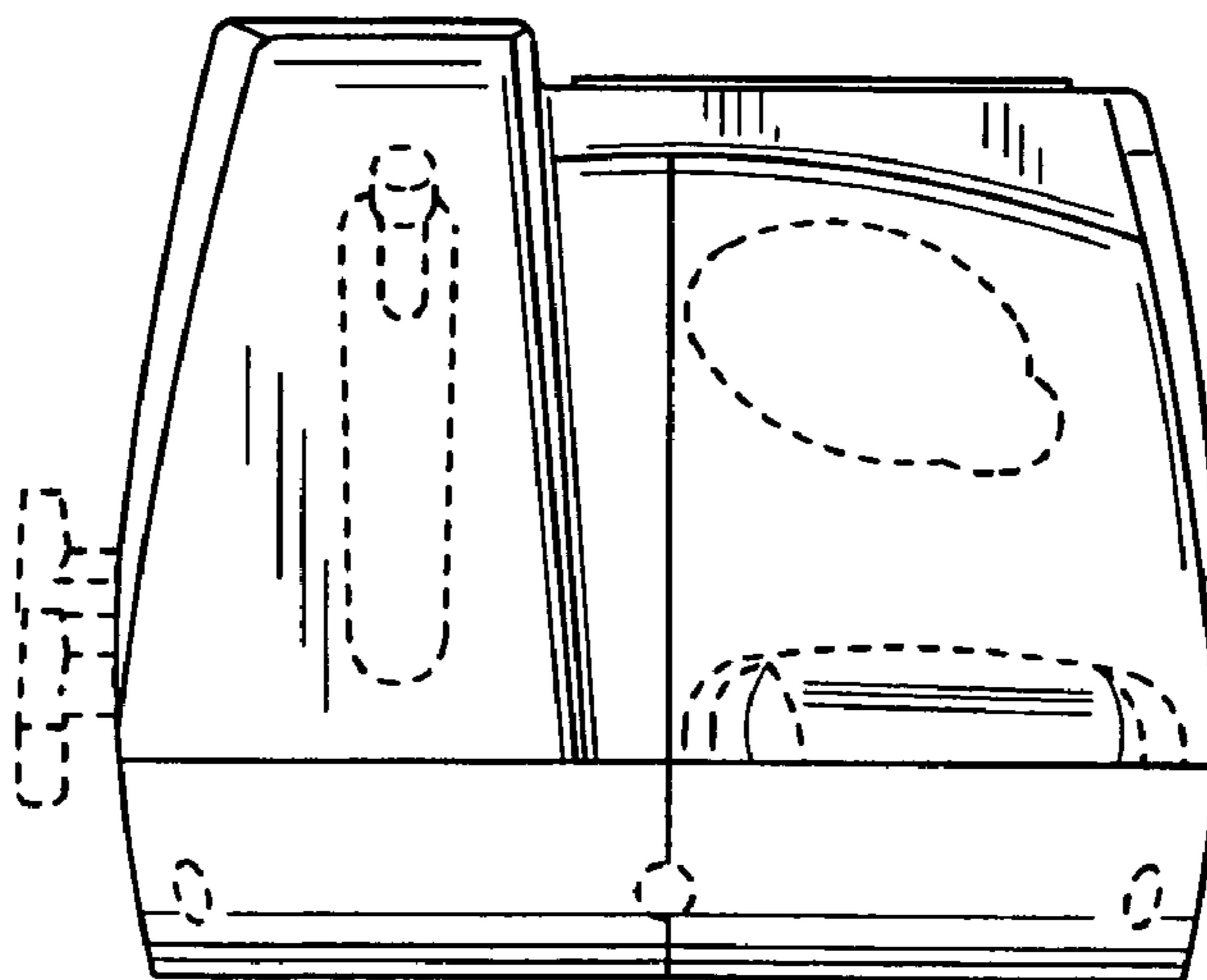

Fig. 10

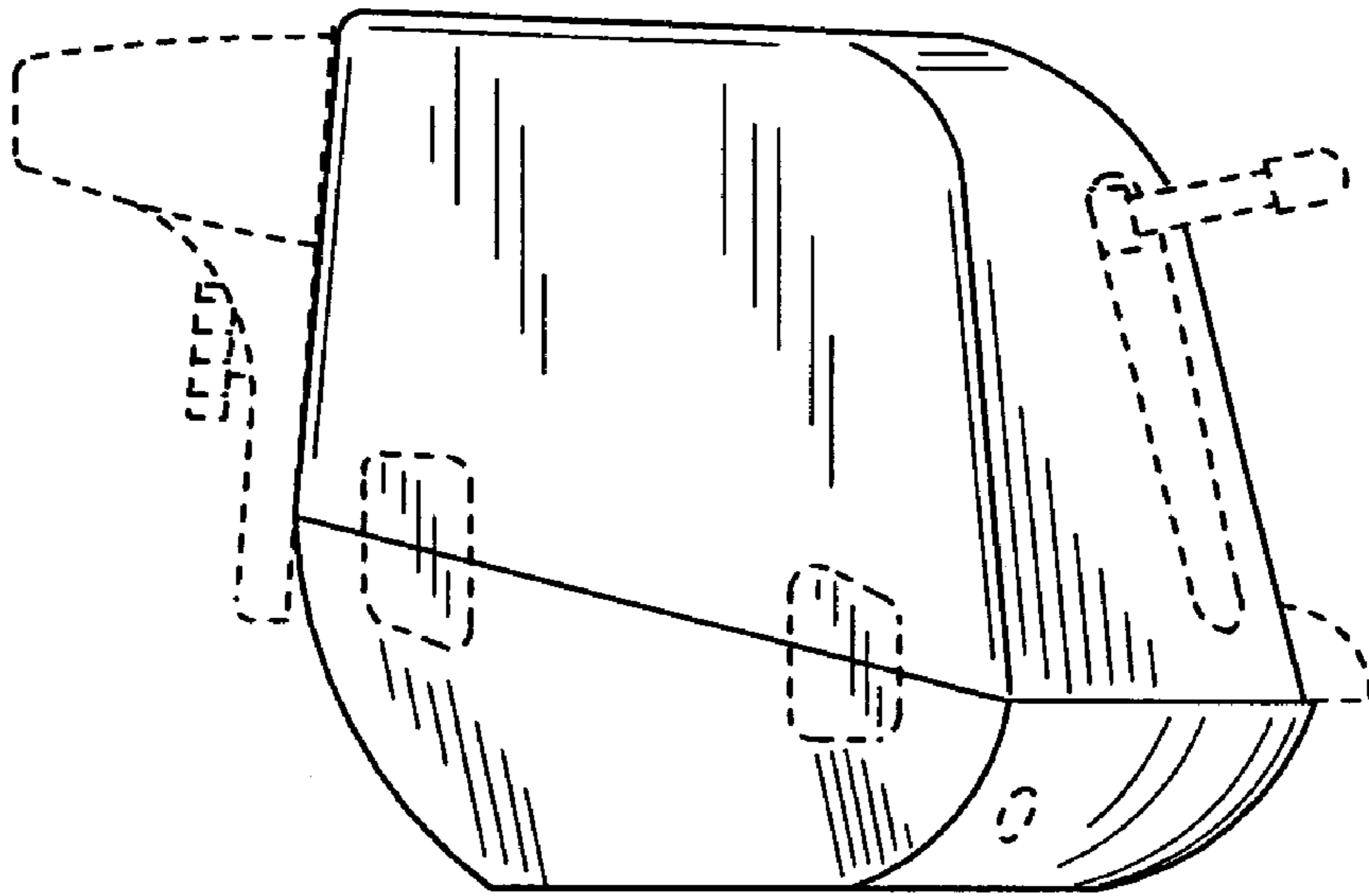

Fig. 11

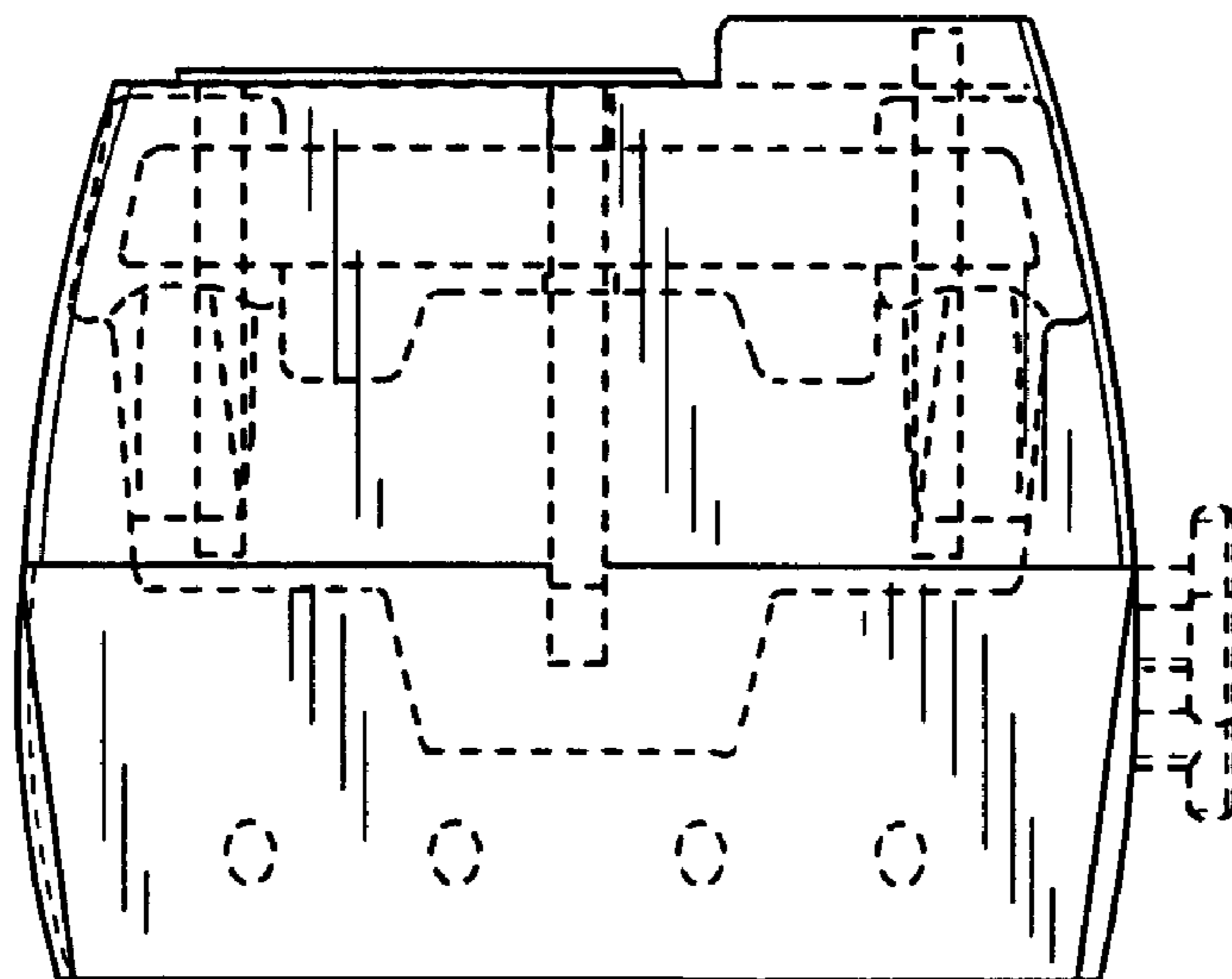

Fig. 12

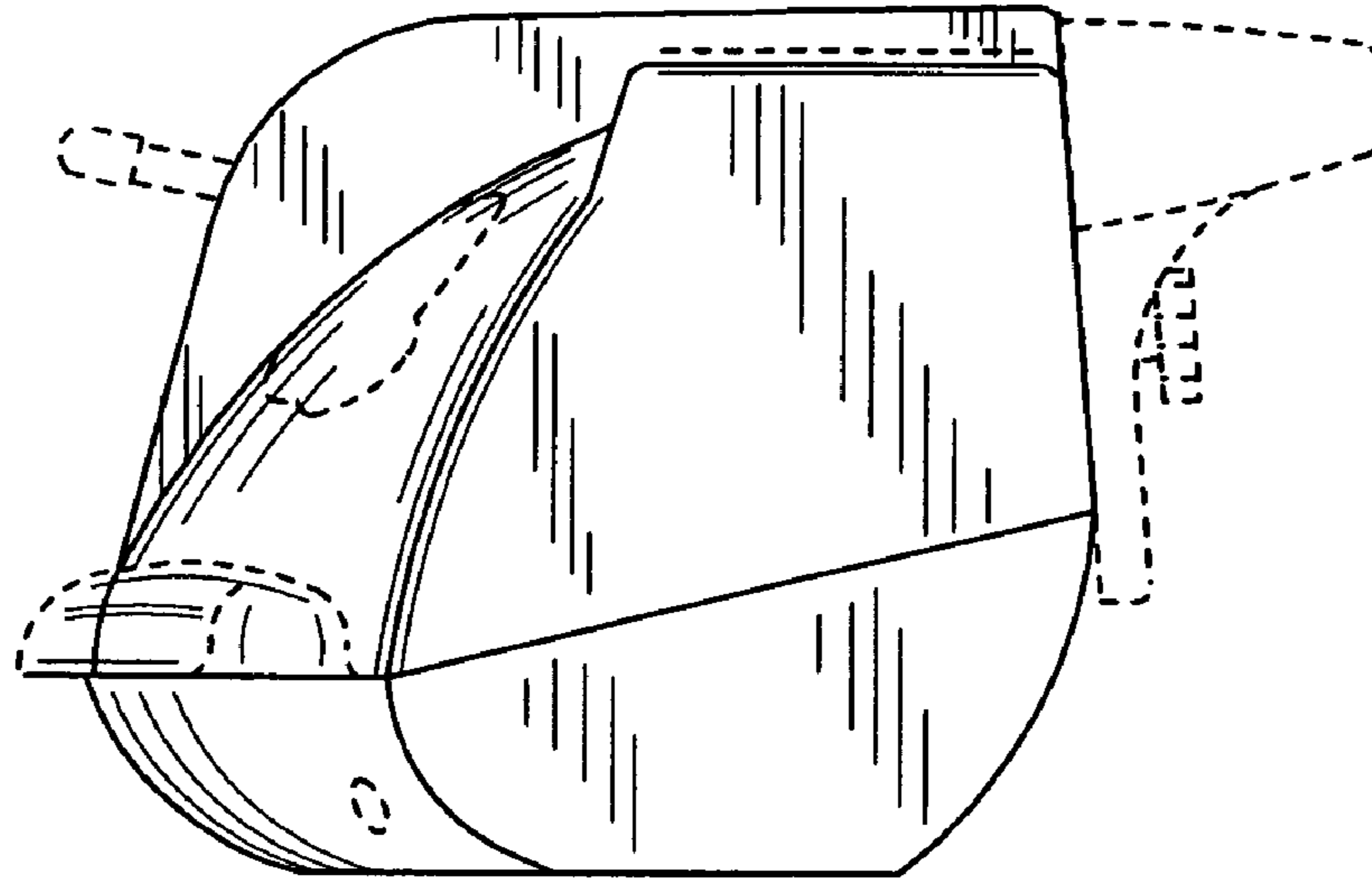

Fig. 13

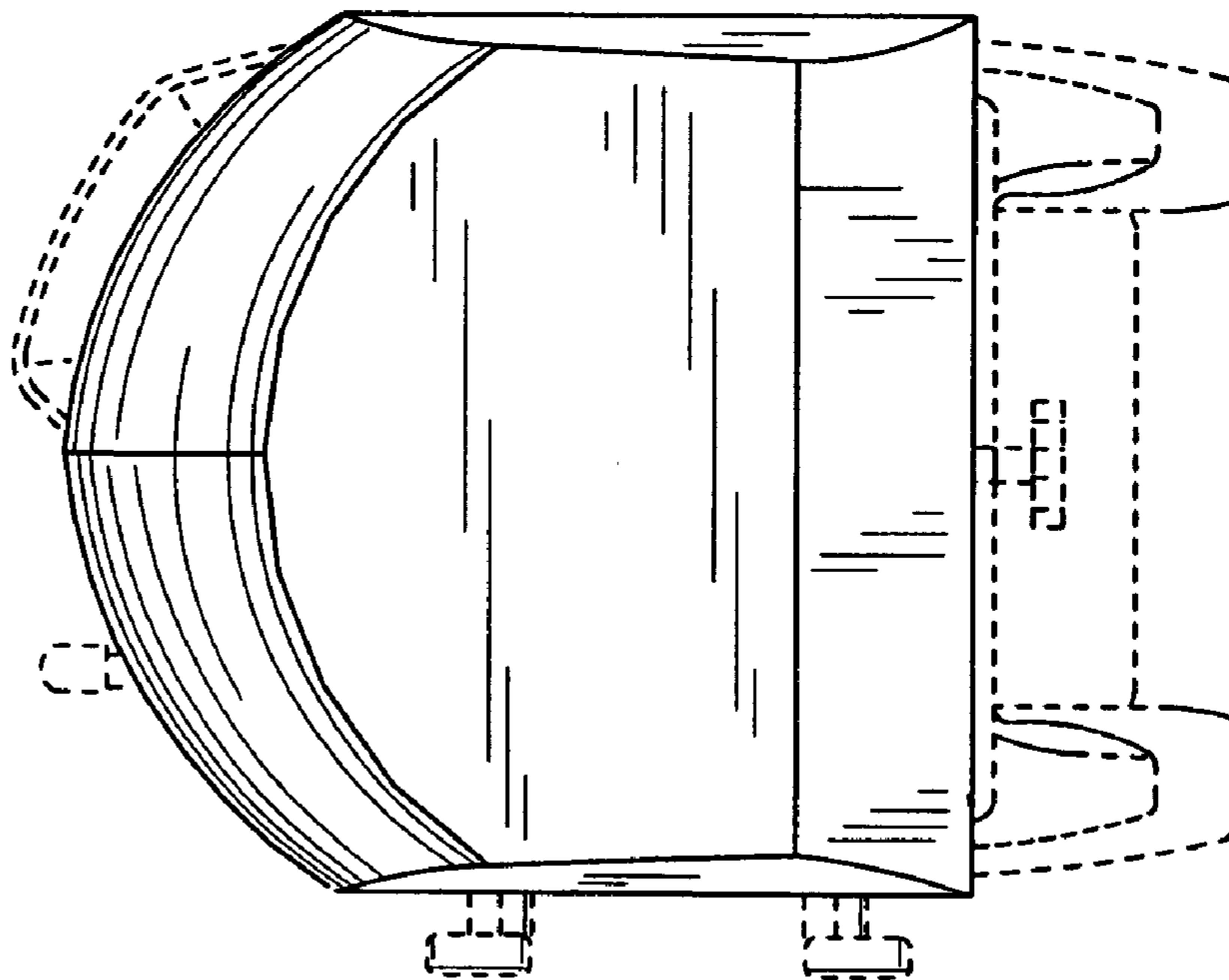

Fig. 14