



US00D551045S

(12) **United States Design Patent**
Kokawa

(10) **Patent No.:** **US D551,045 S**

(45) **Date of Patent:** **** Sep. 18, 2007**

(54) **PORTABLE ELECTRIC SAW**

(75) Inventor: **Kiyozumi Kokawa**, Anjo (JP)

(73) Assignee: **Makita Corporation**, Anjo-Shi (JP)

(**) Term: **14 Years**

(21) Appl. No.: **29/252,928**

(22) Filed: **Jan. 31, 2006**

(30) **Foreign Application Priority Data**

Aug. 1, 2005 (JP) 2005-022269

(51) **LOC (8) Cl.** **08-03**

(52) **U.S. Cl.** **D8/64**

(58) **Field of Classification Search** D8/69,
D8/68, 67, 66, 65, 64, 62, 61; 30/92, 394,
30/393, 392, 377, 376, 371; 74/50, 49; 173/217,
173/216; 83/699.21; 446/145

See application file for complete search history.

(56) **References Cited**

U.S. PATENT DOCUMENTS

- D401,128 S * 11/1998 Zurwelle D8/64
- D428,786 S 8/2000 Hayakawa et al.
- D434,627 S * 12/2000 Buck D8/64
- 6,189,217 B1 * 2/2001 Melvin et al. 30/125
- D440,849 S 4/2001 Sakai et al.
- D440,851 S * 4/2001 Sakai et al. D8/69
- 6,286,609 B1 * 9/2001 Carrier et al. 173/1
- D456,233 S * 4/2002 Main D8/64
- D471,417 S * 3/2003 Chunn et al. D8/64
- D471,418 S * 3/2003 Chunn et al. D8/64

- D473,771 S * 4/2003 Hayakawa et al. D8/64
- D474,088 S * 5/2003 Chunn et al. D8/64
- 6,568,089 B1 * 5/2003 Popik et al. 30/392
- D480,616 S 10/2003 Welsh
- D507,953 S * 8/2005 Watson et al. D8/69
- D523,310 S * 6/2006 Wikle et al. D8/64
- D523,312 S * 6/2006 Ozawa et al. D8/64
- D524,131 S * 7/2006 Chunn et al. D8/64
- D524,132 S * 7/2006 Welsh D8/64
- D524,619 S * 7/2006 Ng D8/64
- D525,845 S * 8/2006 Welsh D8/64
- D526,177 S * 8/2006 Lui D8/64

* cited by examiner

Primary Examiner—Cathron C. Brooks

Assistant Examiner—Austin Murphy

(74) *Attorney, Agent, or Firm*—Oliff & Berridge, PLC.

(57) **CLAIM**

The ornamental design for a portable electric saw, as shown and described.

DESCRIPTION

FIG. 1 is a perspective view of a portable electric saw showing my new design;

FIG. 2 is a front elevation view thereof;

FIG. 3 is a rear elevation view thereof;

FIG. 4 is a left side elevation view thereof;

FIG. 5 is a right side elevation view thereof;

FIG. 6 is a top plan view thereof; and,

FIG. 7 is a bottom plan view thereof.

1 Claim, 5 Drawing Sheets

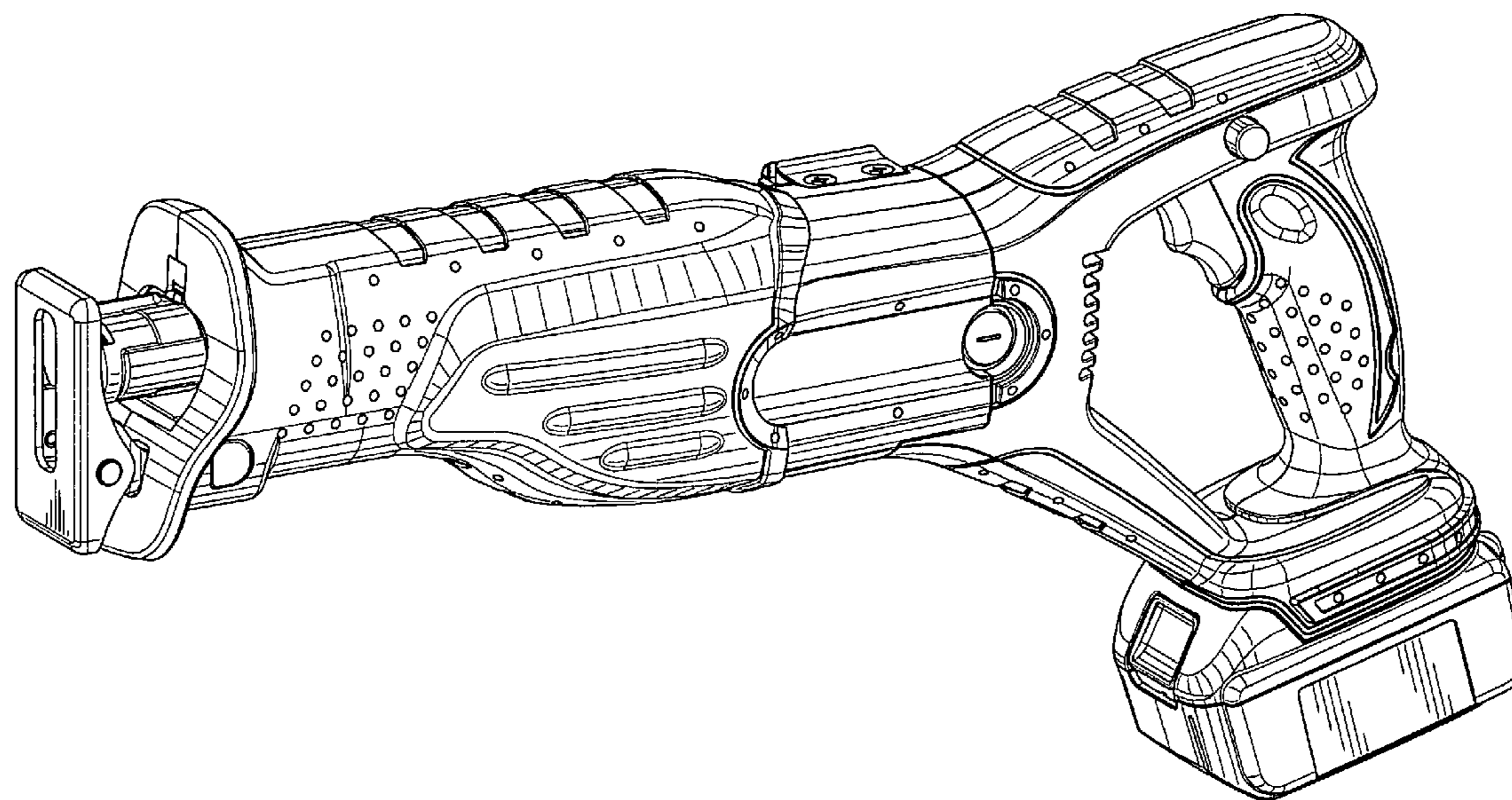

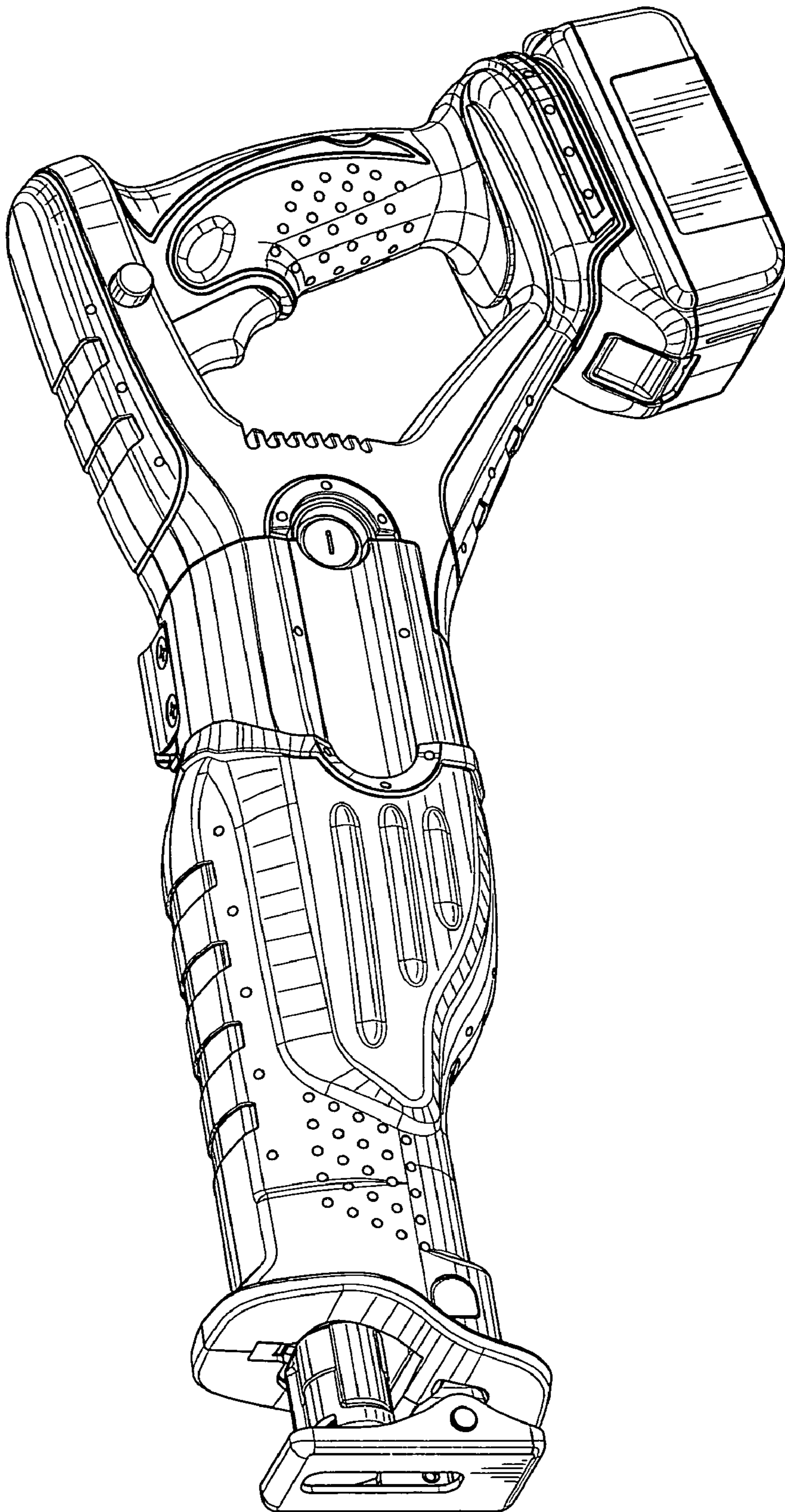

FIG. 1

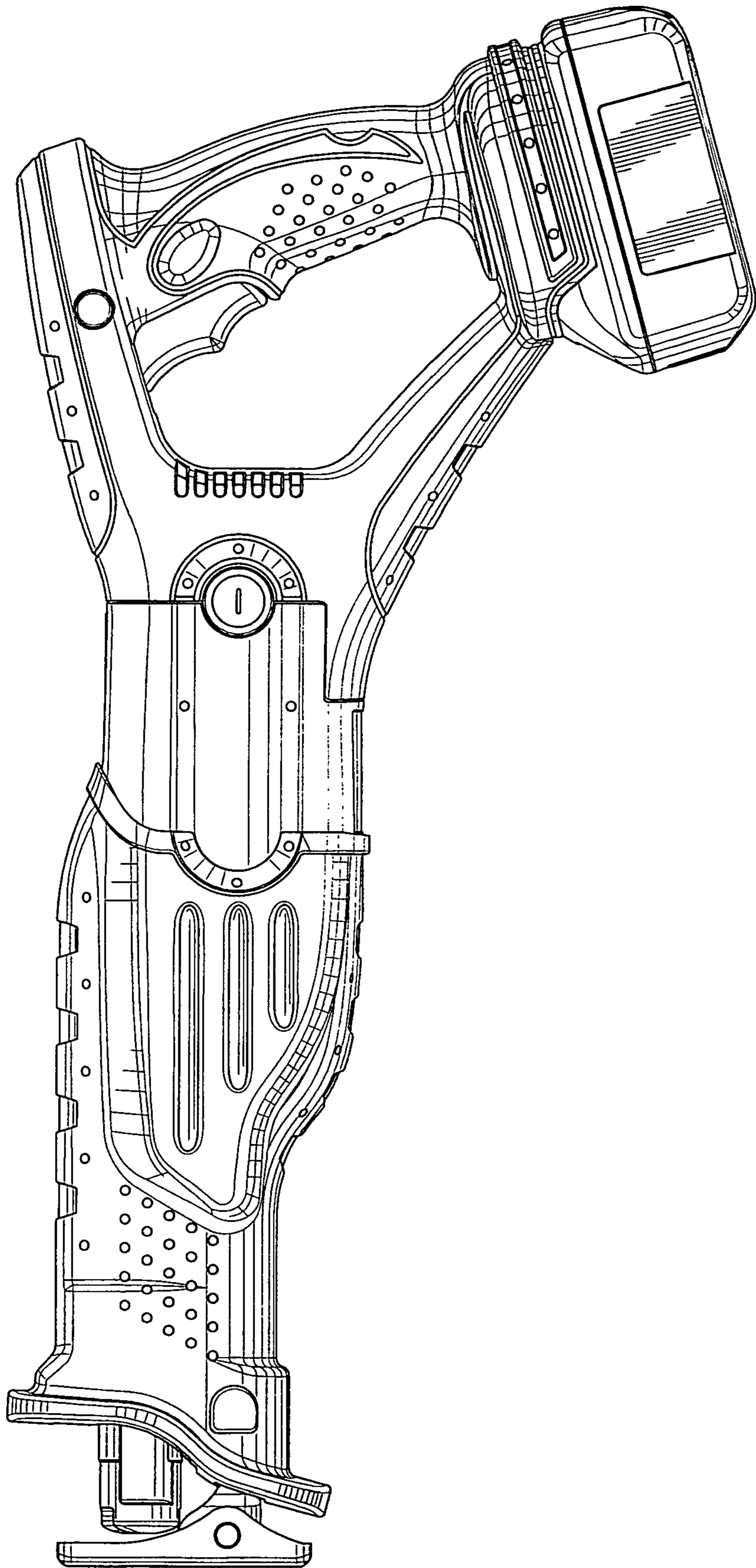

FIG. 2

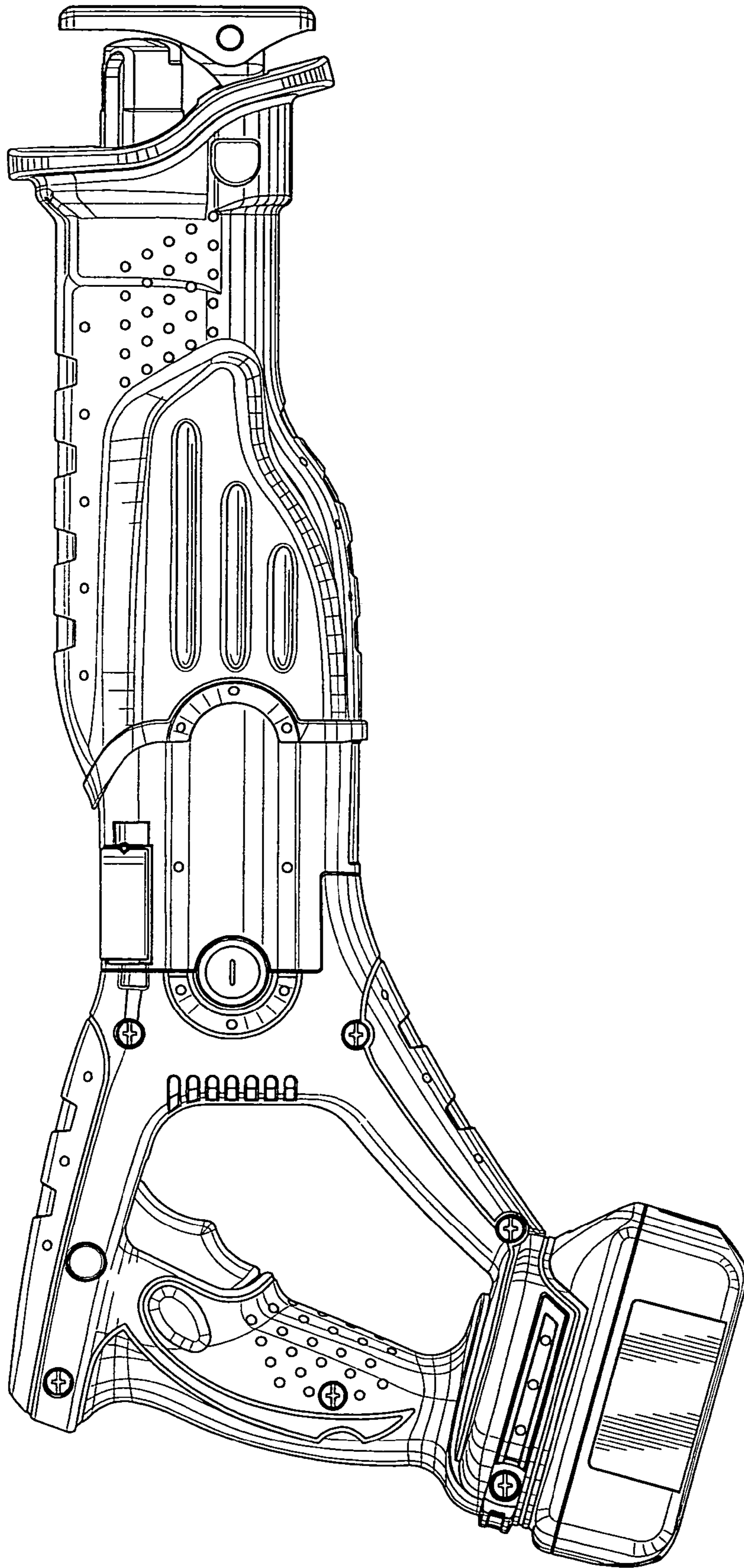

FIG. 3

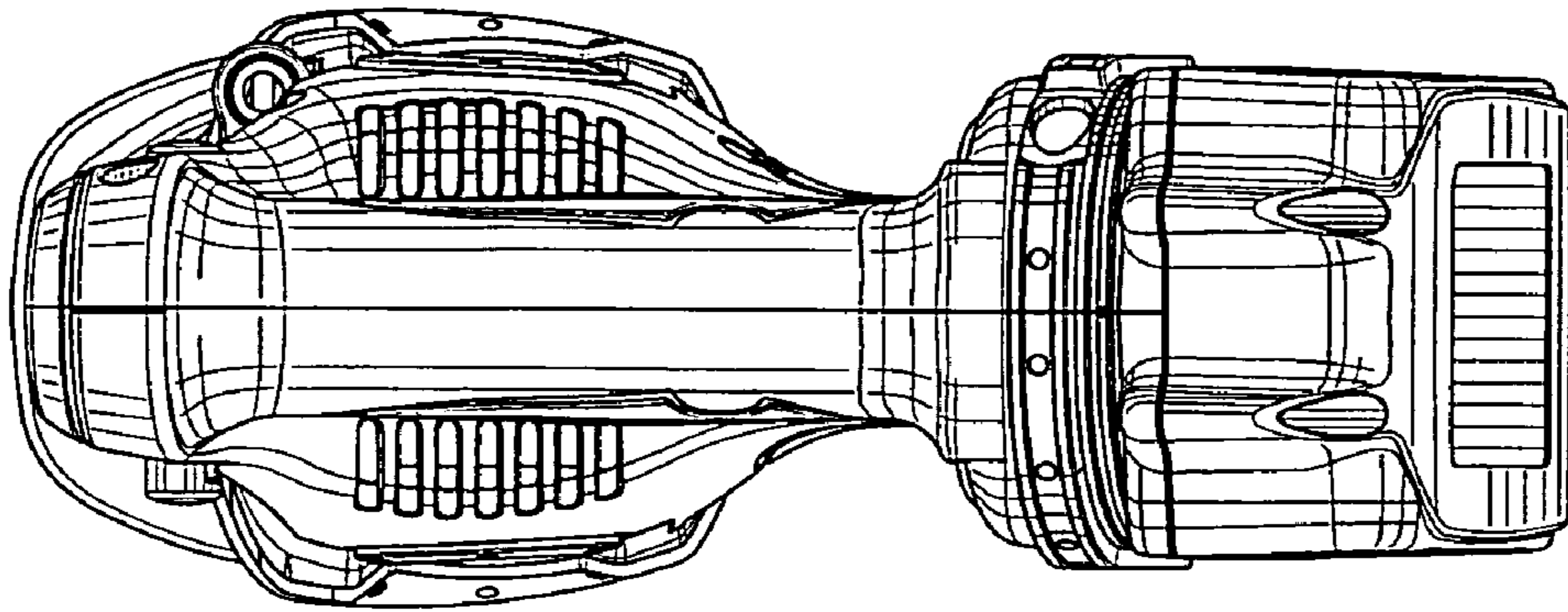

FIG. 5

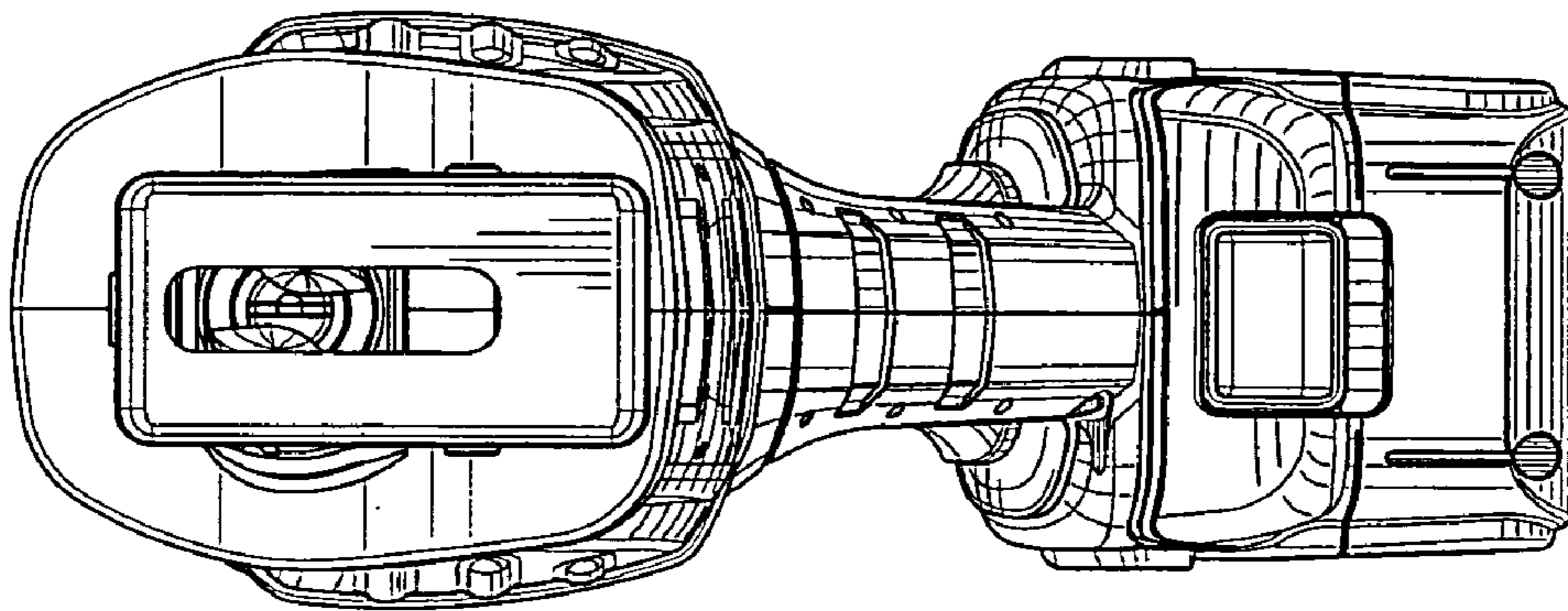

FIG. 4

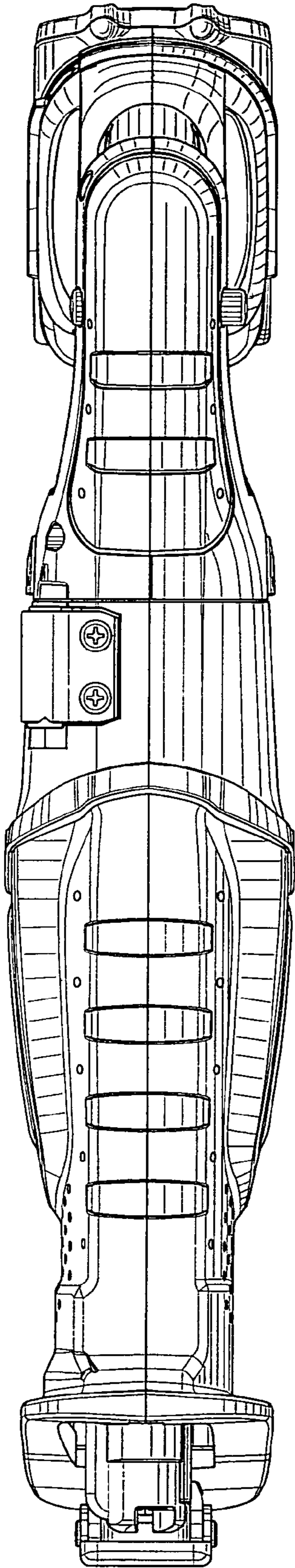

FIG. 6

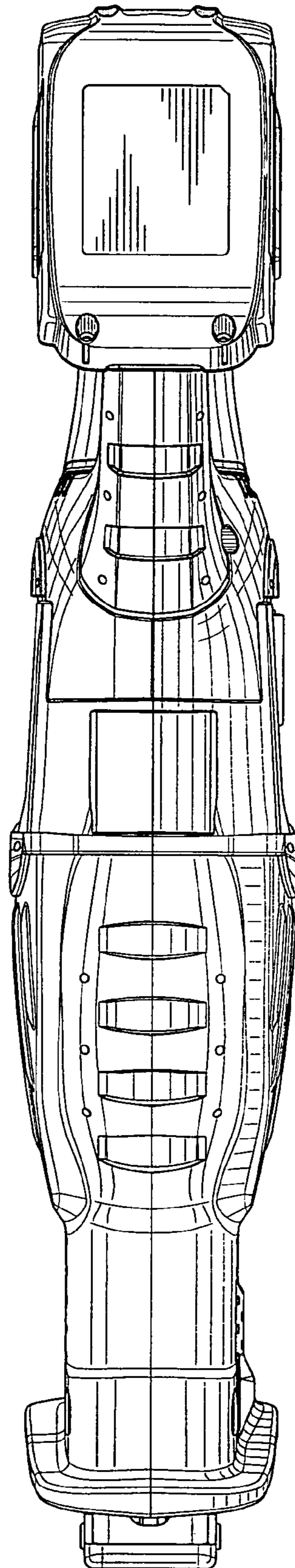

FIG. 7