



US00D550589S

(12) **United States Design Patent** (10) **Patent No.:** **US D550,589 S**
Brockington et al. (45) **Date of Patent:** **** Sep. 11, 2007**

(54) **WIND ASSISTED RV HOLDING TANK VENT**

D453,823 S * 2/2002 Wagner D23/370
D456,889 S * 5/2002 Rossman D23/370
6,468,147 B1 * 10/2002 Thomas 454/136

(75) Inventors: **William T. Brockington**, Kernersville, NC (US); **Clay D. Price**, Stokesdale, NC (US); **Jeffrey R. Russell**, Winston Salem, NC (US)

(73) Assignee: **Camco Manufacturing, Inc.**, Greensboro, NC (US)

(**) Term: **14 Years**

(21) Appl. No.: **29/252,808**

(22) Filed: **Jan. 27, 2006**

(51) **LOC (8) Cl.** **12-10**

(52) **U.S. Cl.** **D12/106**

(58) **Field of Classification Search** D12/101–106,
D12/400, 317; D23/263, 370, 375, 324,
D23/373, 393–394; 4/216, 218, 321; 296/216.02;
454/136, 199, 367.94; 114/211, 201 R; 141/301,
141/387, 65; 210/199

See application file for complete search history.

(56) **References Cited**

U.S. PATENT DOCUMENTS

2,728,921 A	1/1956	Dorko	
3,192,539 A	7/1965	Martz	
3,230,552 A	1/1966	Schulz	
3,551,916 A	1/1971	Ried	
3,776,383 A	12/1973	Hargraves	
3,981,323 A	9/1976	Watson	
4,615,263 A *	10/1986	Titterud	454/94
D316,595 S *	4/1991	Sauber	D23/324
D330,588 S *	10/1992	Lindeen	D23/373
D365,873 S *	1/1996	Van Belle	D12/317
D376,007 S *	11/1996	Thomas	D23/393
D389,564 S *	1/1998	Owusu	D23/324
D428,130 S *	7/2000	Zirk	D23/393
6,189,161 B1	2/2001	Rijn et al.	

OTHER PUBLICATIONS

Ref. No. 1, RV-360 Rotating Vent/Odor Extractor, RV-360 website (www.RV-360.com), Dec. 27, 2005.

Ref. No. 2, Vac-U- Jet RV Roof Vent, PPL Motor Homes website (www.pplmotorhomes.com), Dec. 27, 2005.

* cited by examiner

Primary Examiner—Stacia Cadmus

(57) **CLAIM**

The ornamental design for an wind assisted RV holding tank vent, as shown and described.

DESCRIPTION

FIG. 1 is a front elevational view of our design;
FIG. 2 is a transverse sectional view taken along line 2—2 in FIG. 1;
FIG. 3 is a rear elevational view of our design;
FIG. 4 is a top plan view of our design;
FIG. 5 is a bottom plan view of our design;
FIG. 6 is a top, right front perspective view embodying our design;
FIG. 7 is a right side elevational view of our design and the left side elevational view being a mirror image;
FIG. 8 is a sectional view taken along line 8—8 in FIG. 7; and,
FIG. 9 is a sectional view taken along line 9—9 in FIG. 7; and,
FIG. 10 is a bottom, left rear perspective view embodying our design and being some what enlarged from that of FIGS. 1 through 9.

1 Claim, 5 Drawing Sheets

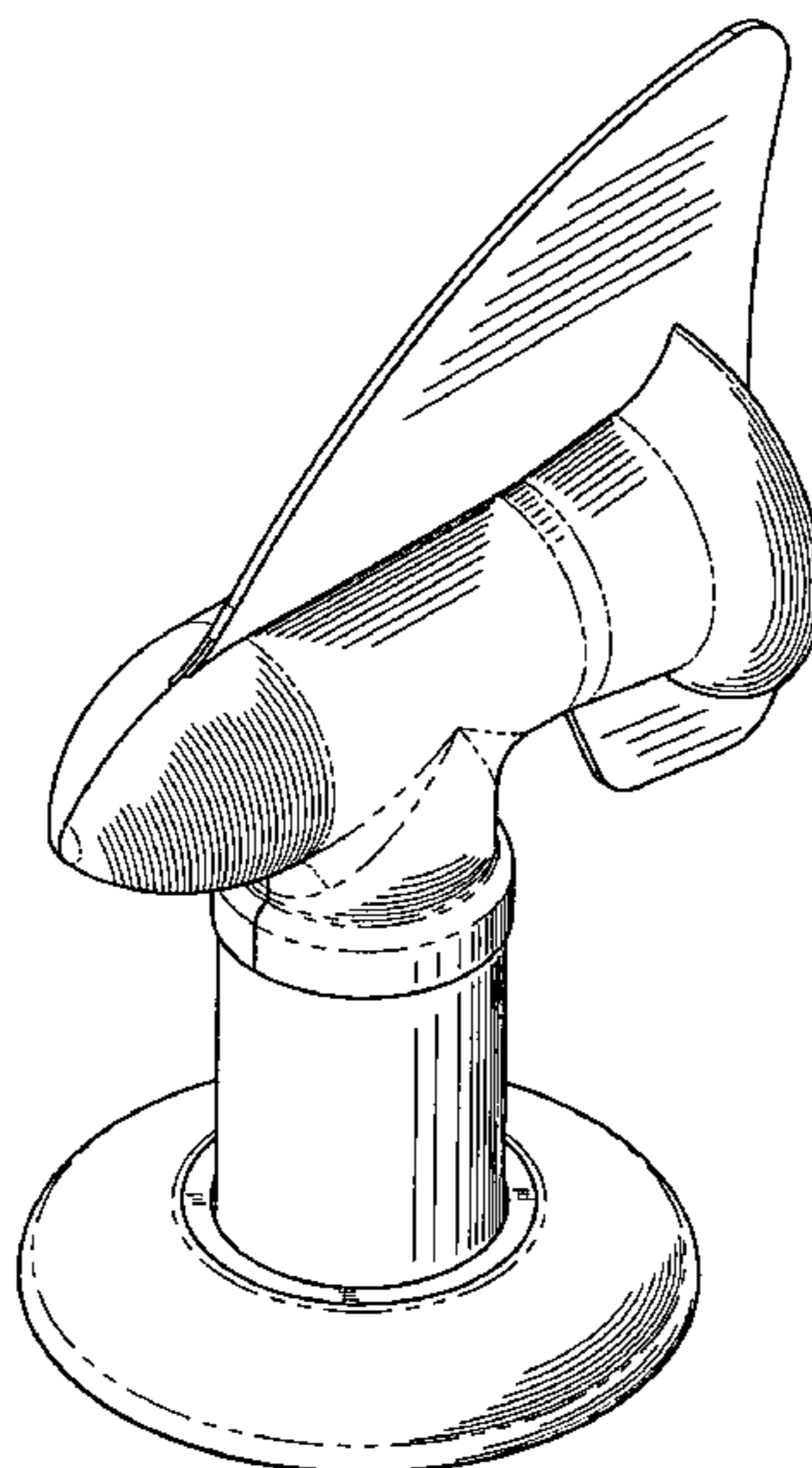

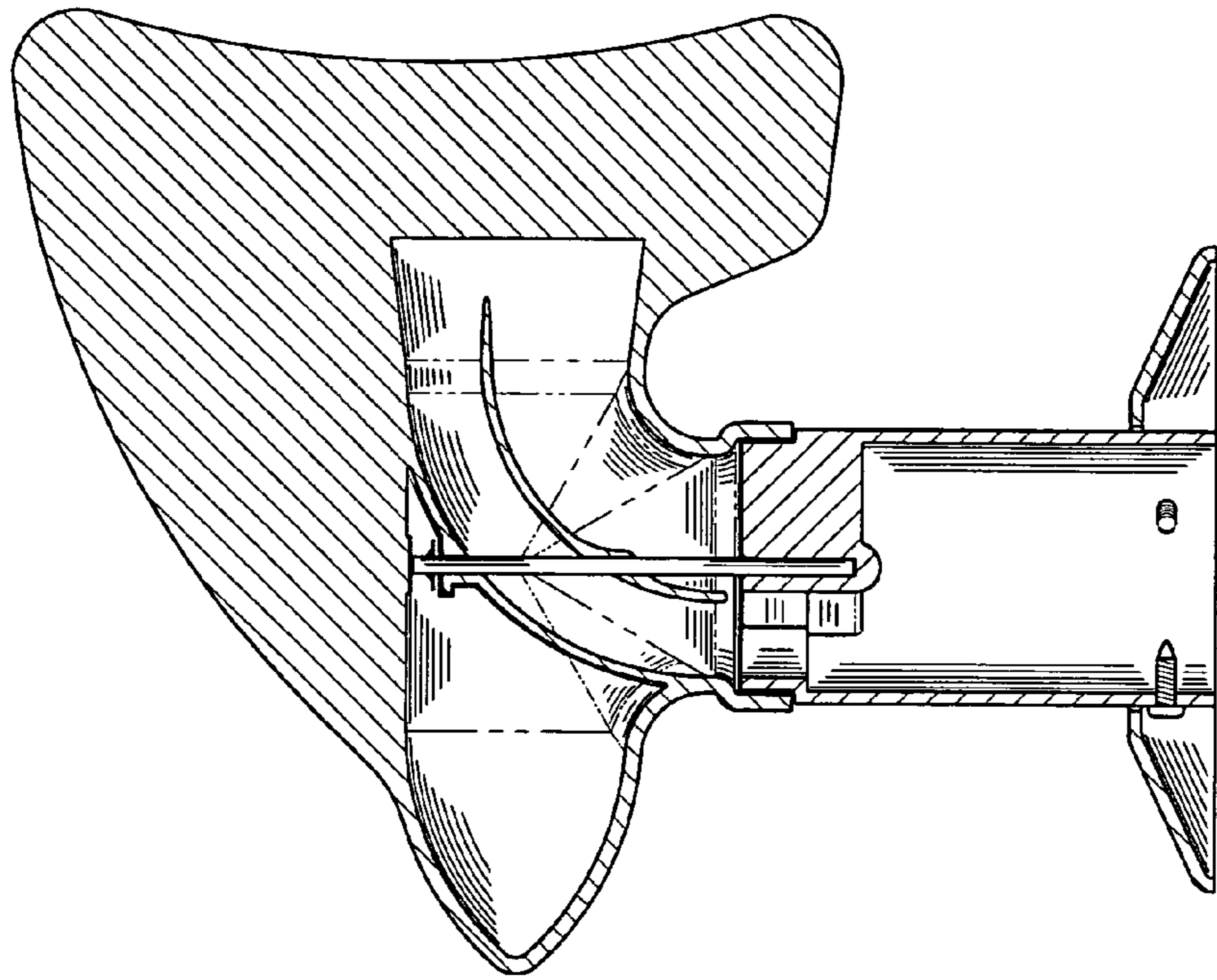
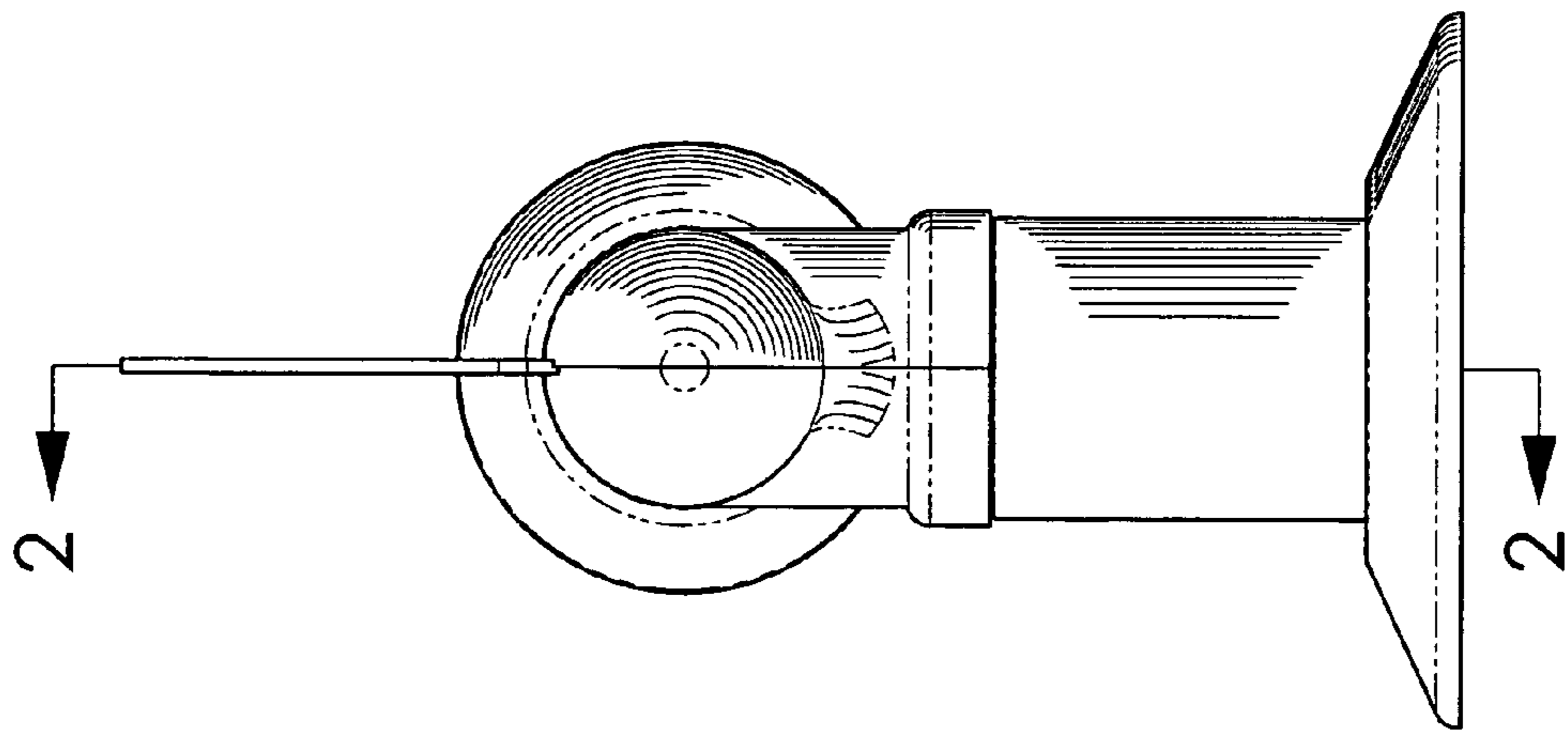

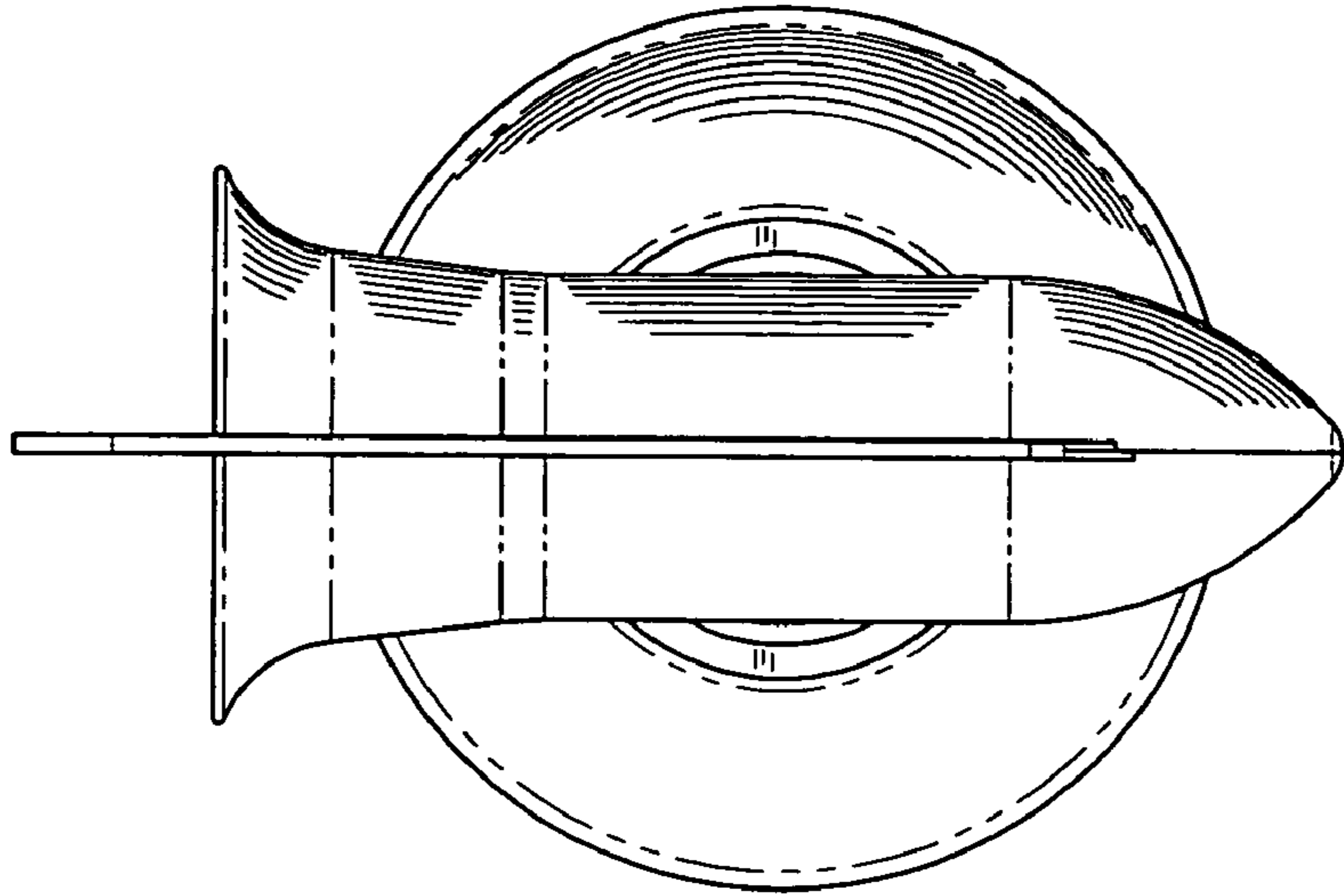

FIG. 4

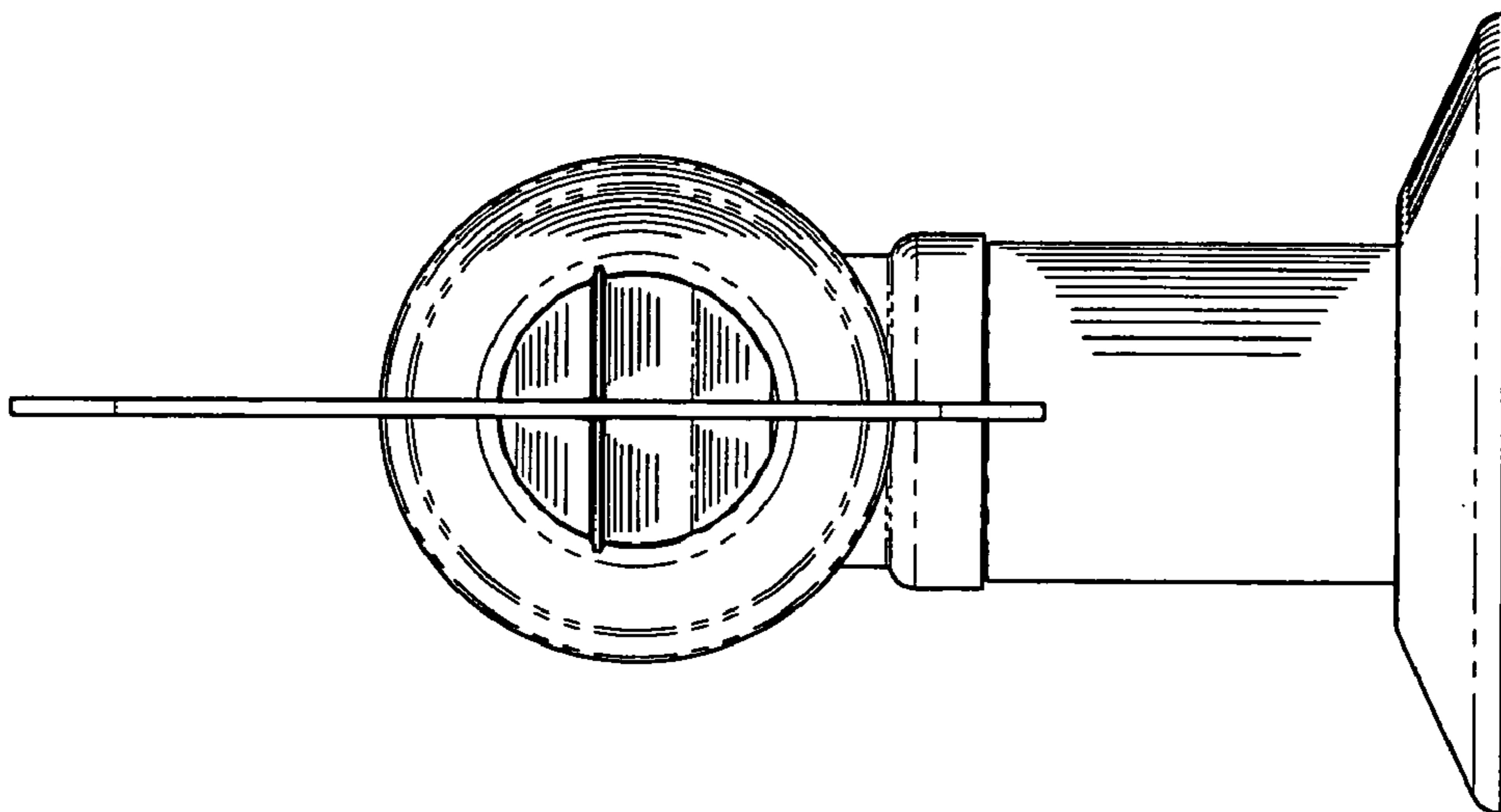

FIG. 3

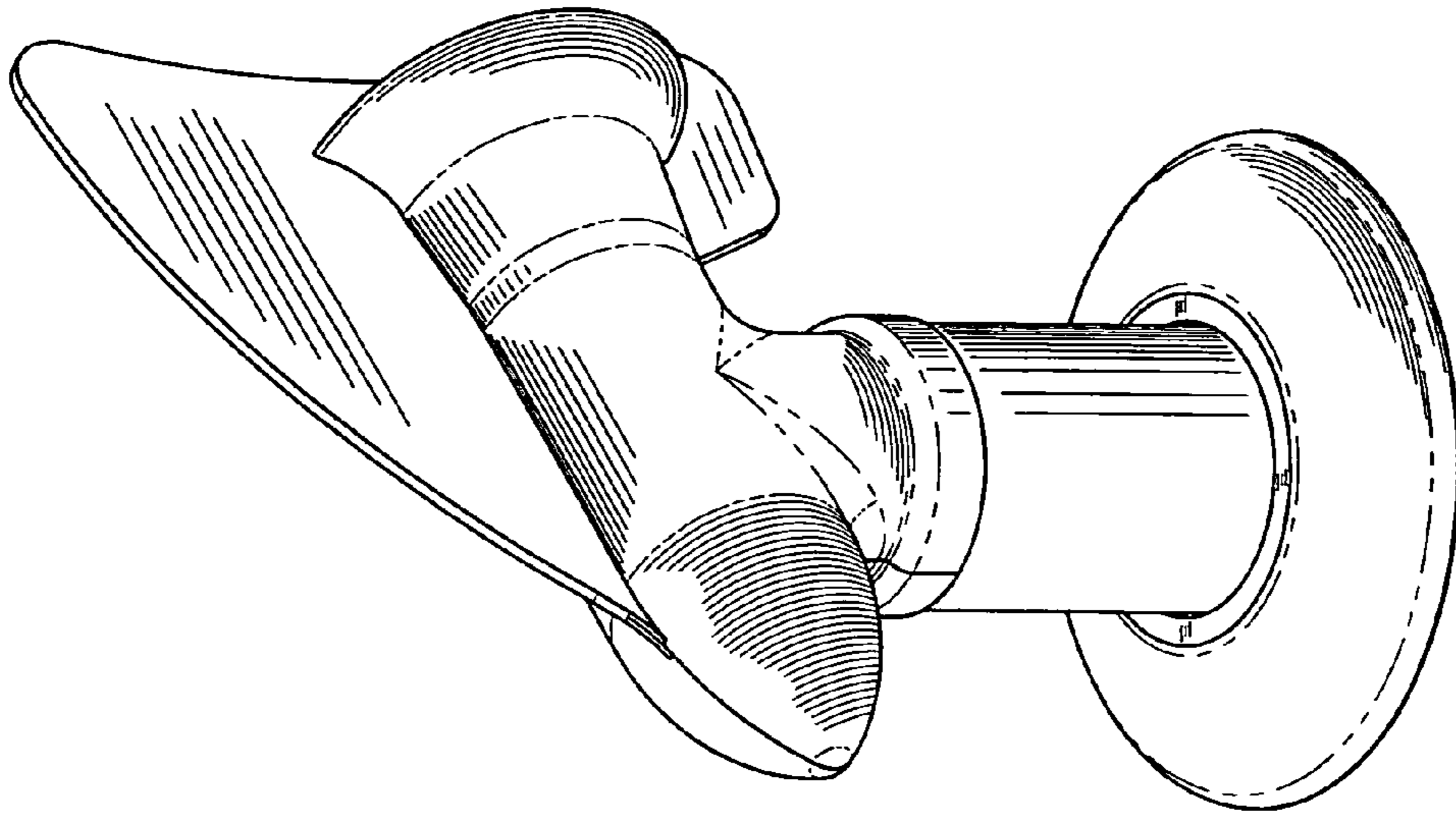

FIG. 6

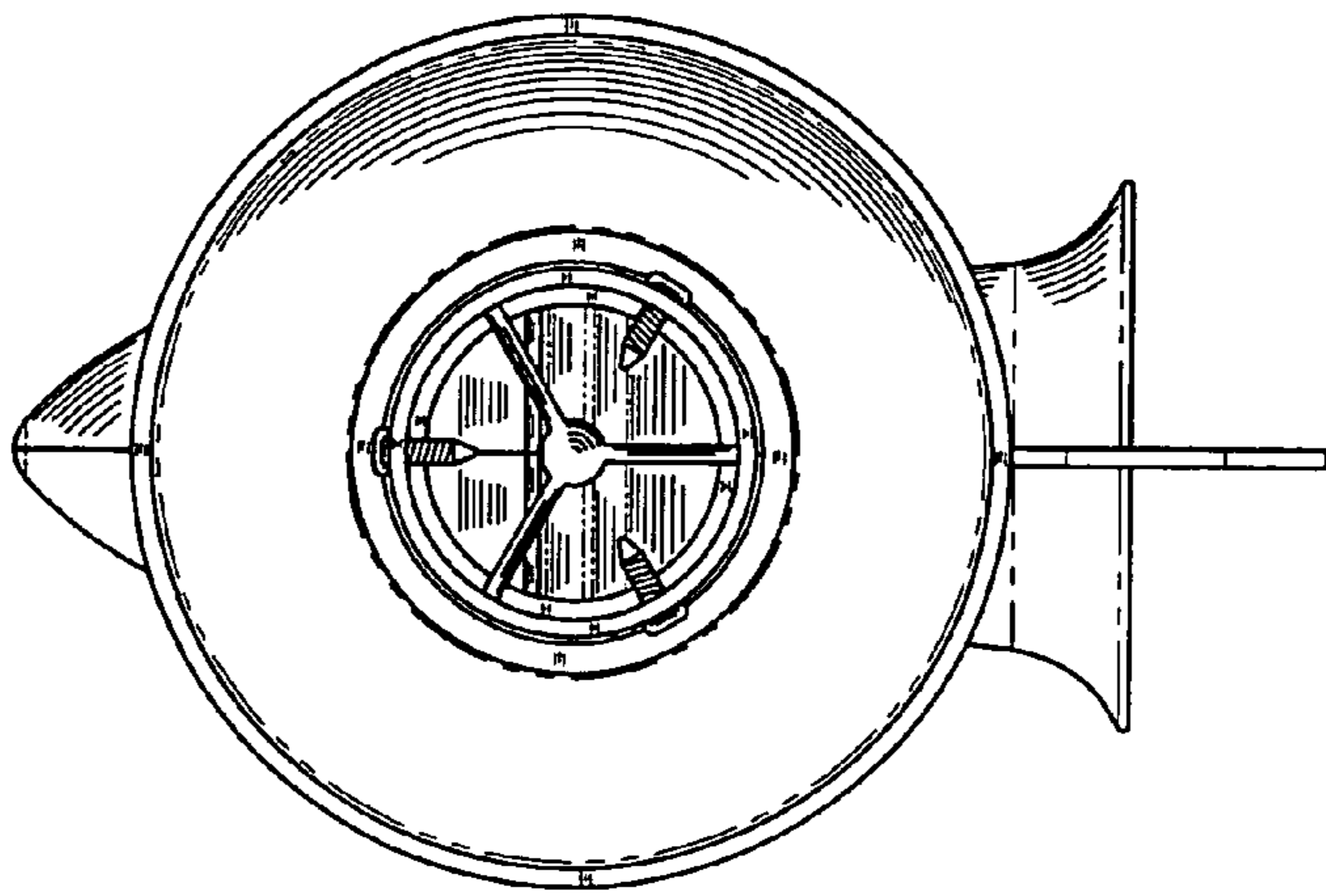

FIG. 5

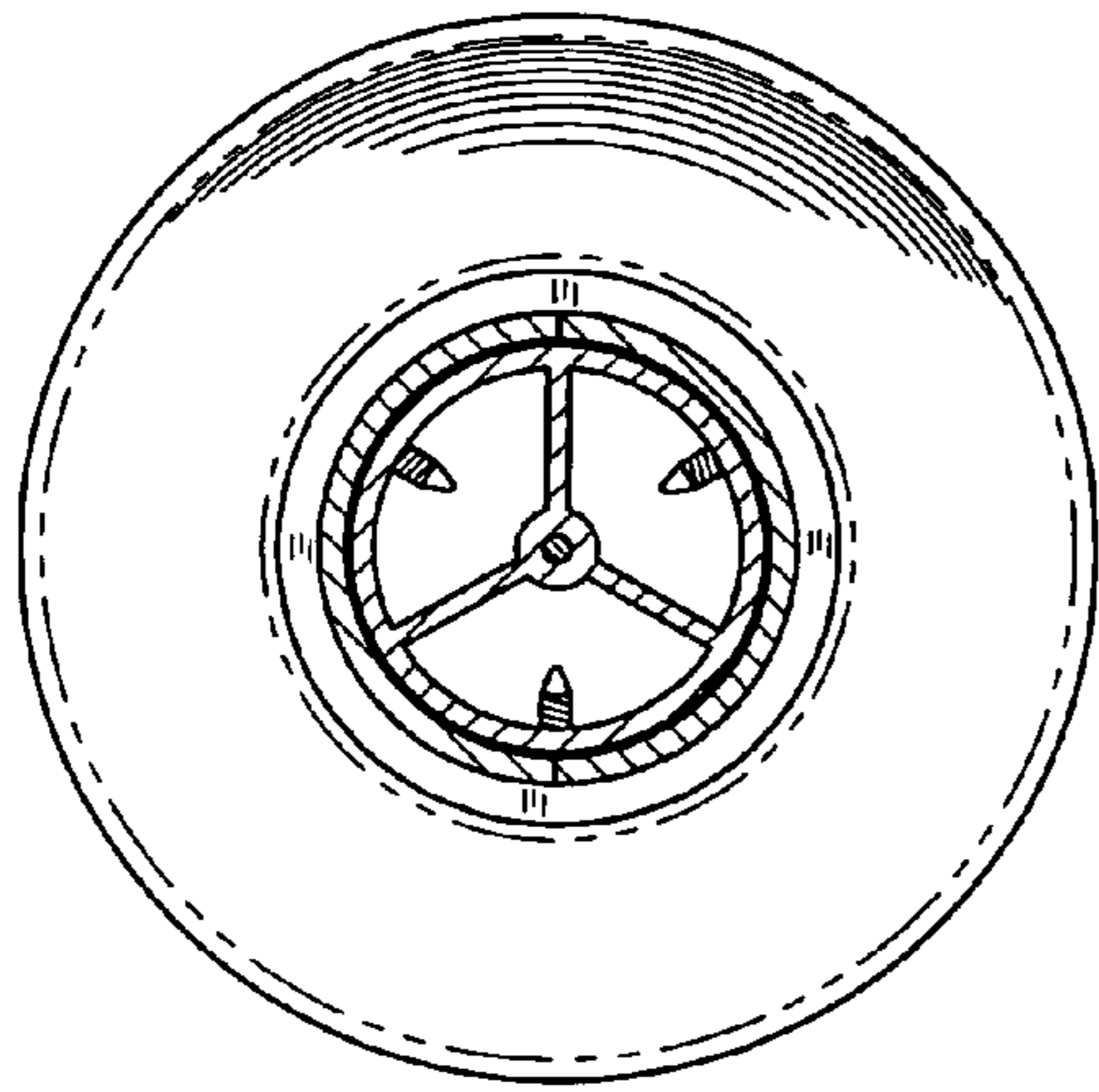

FIG. 8

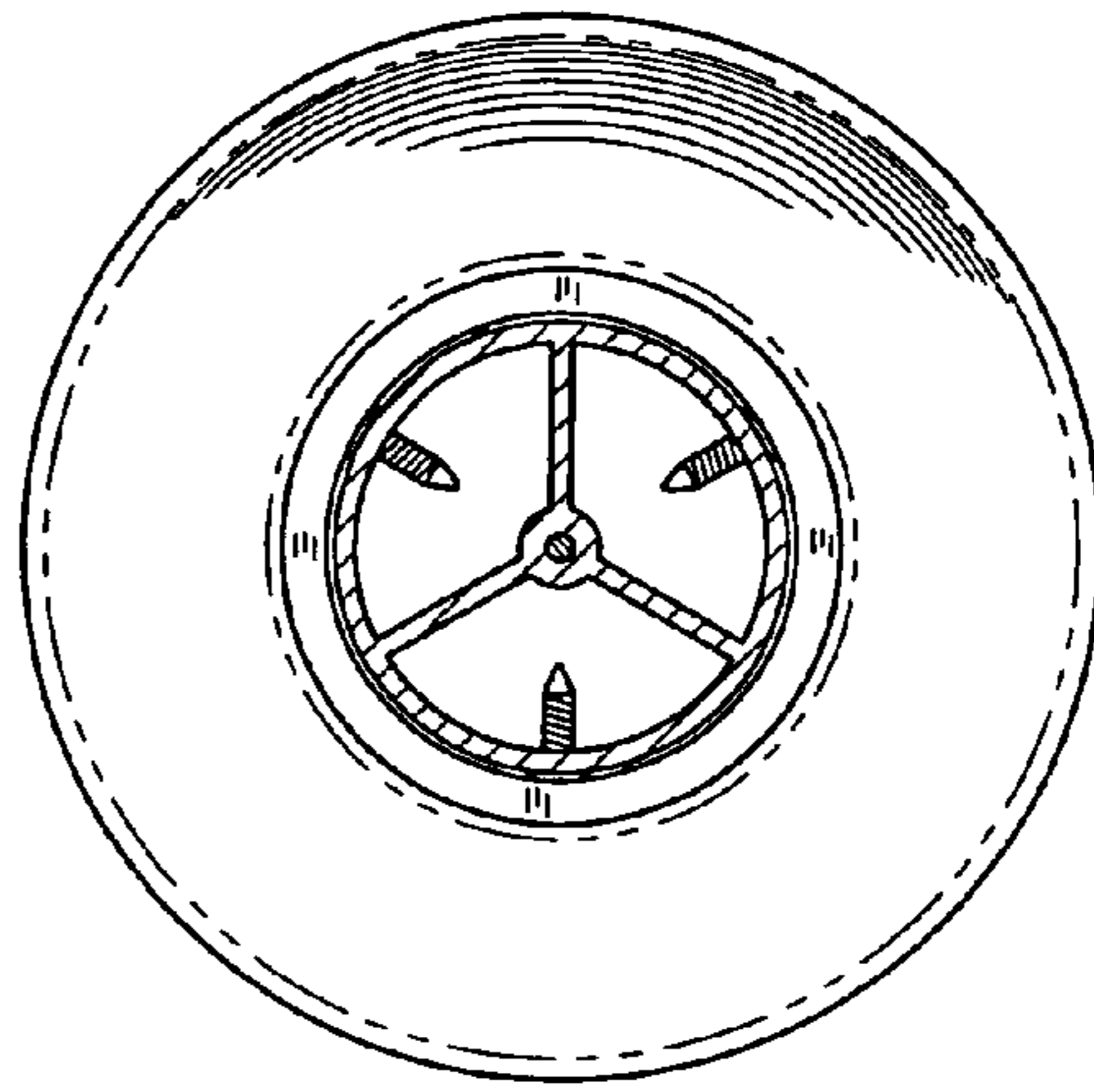

FIG. 9

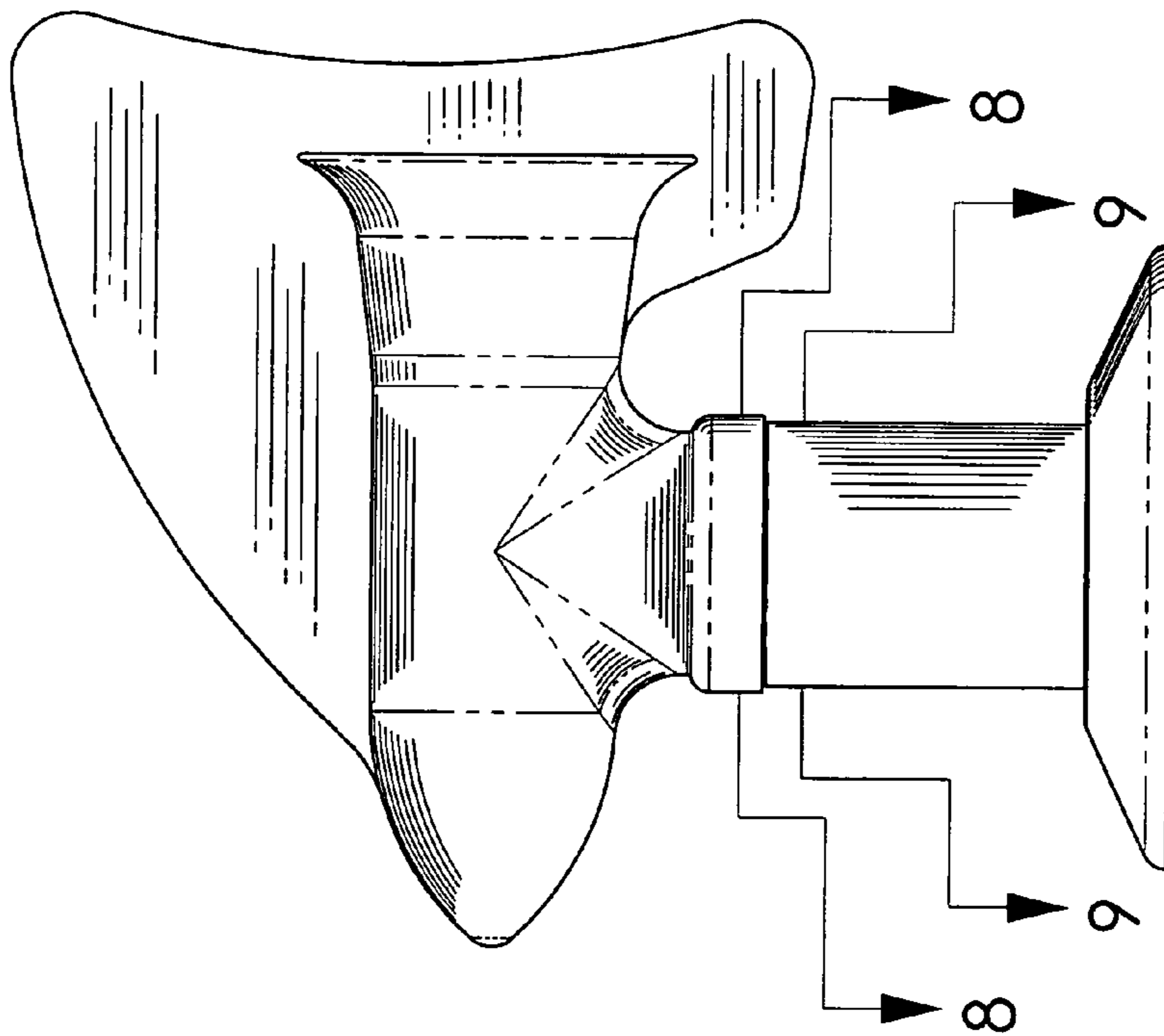

FIG. 7

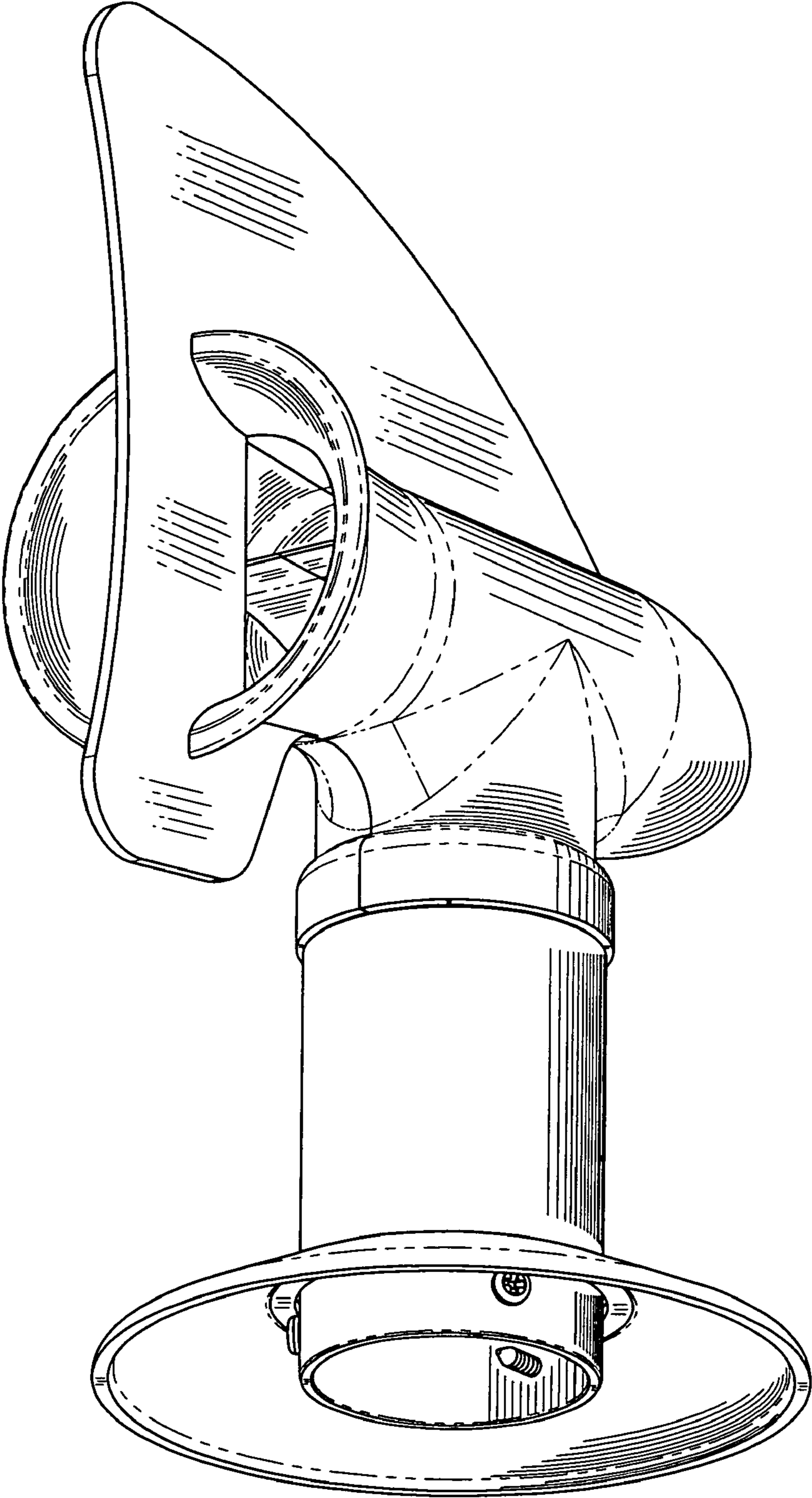

FIG. 10