



US00D550207S

(12) **United States Design Patent**  
**Mizokawa**

(10) **Patent No.:** **US D550,207 S**

(45) **Date of Patent:** **\*\* Sep. 4, 2007**

(54) **SPEAKER FOR AN AUTOMOBILE**

D320,020 S 9/1991 Iwano  
D336,475 S \* 6/1993 Christie ..... D14/215  
6,095,278 A \* 8/2000 Lin ..... 181/148

(75) Inventor: **Hiroyuki Mizokawa**, Osaka (JP)

(73) Assignee: **Matsushita Electric Industrial Co., Ltd.**, Osaka (JP)

(Continued)

(\*\*) Term: **14 Years**

JP D1157504 11/2002  
JP D1157505 11/2002

(21) Appl. No.: **29/260,726**

FOREIGN PATENT DOCUMENTS

(22) Filed: **May 31, 2006**

(Continued)

(30) **Foreign Application Priority Data**

*Primary Examiner*—Nanda Bondade  
(74) *Attorney, Agent, or Firm*—Brinks Hofer Gilson & Lione

Dec. 2, 2005 (JP) ..... 2005-035665

(51) **LOC (8) Cl.** ..... **14-01**

(52) **U.S. Cl.** ..... **D14/216**; D14/221

(58) **Field of Classification Search** ..... D14/204,  
D14/209–216, 221–222; 181/143–144, 147–148,  
181/150, 157, 198–199, 151, 153; 381/300–302,  
381/306, 333, 345, 361–364, 386–388, 332,  
381/336

See application file for complete search history.

(57) **CLAIM**

I claim the ornamental design for a speaker for an automobile, as shown and described.

(56) **References Cited**

**DESCRIPTION**

U.S. PATENT DOCUMENTS

D87,689 S 8/1932 Sinel  
D186,670 S 11/1959 Durbin  
D188,542 S 8/1960 Levy et al.  
D197,716 S 3/1964 Boldt et al.  
D253,108 S 10/1979 Schroeder  
D254,252 S \* 2/1980 Matsubara ..... D14/216  
D265,086 S 6/1982 Kawachi  
D265,556 S \* 7/1982 Iijima ..... D14/216  
D270,909 S 10/1983 Iijima  
D273,008 S 3/1984 Ishizaki  
D281,065 S \* 10/1985 Katsuno ..... D14/215  
4,837,839 A \* 6/1989 Andrews ..... 381/182  
D302,556 S \* 8/1989 Weissberg et al. .... D14/222  
D302,695 S \* 8/1989 Weissberg et al. .... D14/222  
4,965,837 A 10/1990 Murayama et al.  
D317,160 S 5/1991 Kurata et al.

FIG. 1 is a top perspective view of a speaker for an automobile of the present invention;

FIG. 2 is a front view thereof;

FIG. 3 is a top view thereof;

FIG. 4 is a first side view thereof;

FIG. 5 is a second side view thereof;

FIG. 6 is a bottom view thereof;

FIG. 7 is a rear view thereof;

FIG. 8 is a cross-section view taken along the line 8–8' of FIG. 2; and,

FIG. 9 is a cross-section view taken along the line of 9–9' of FIG. 2.

The ornamental design which is claimed is shown in solid lines in the drawings. Any broken lines in the drawings are for illustrative purposes only and form no part of the claimed design.

**1 Claim, 4 Drawing Sheets**

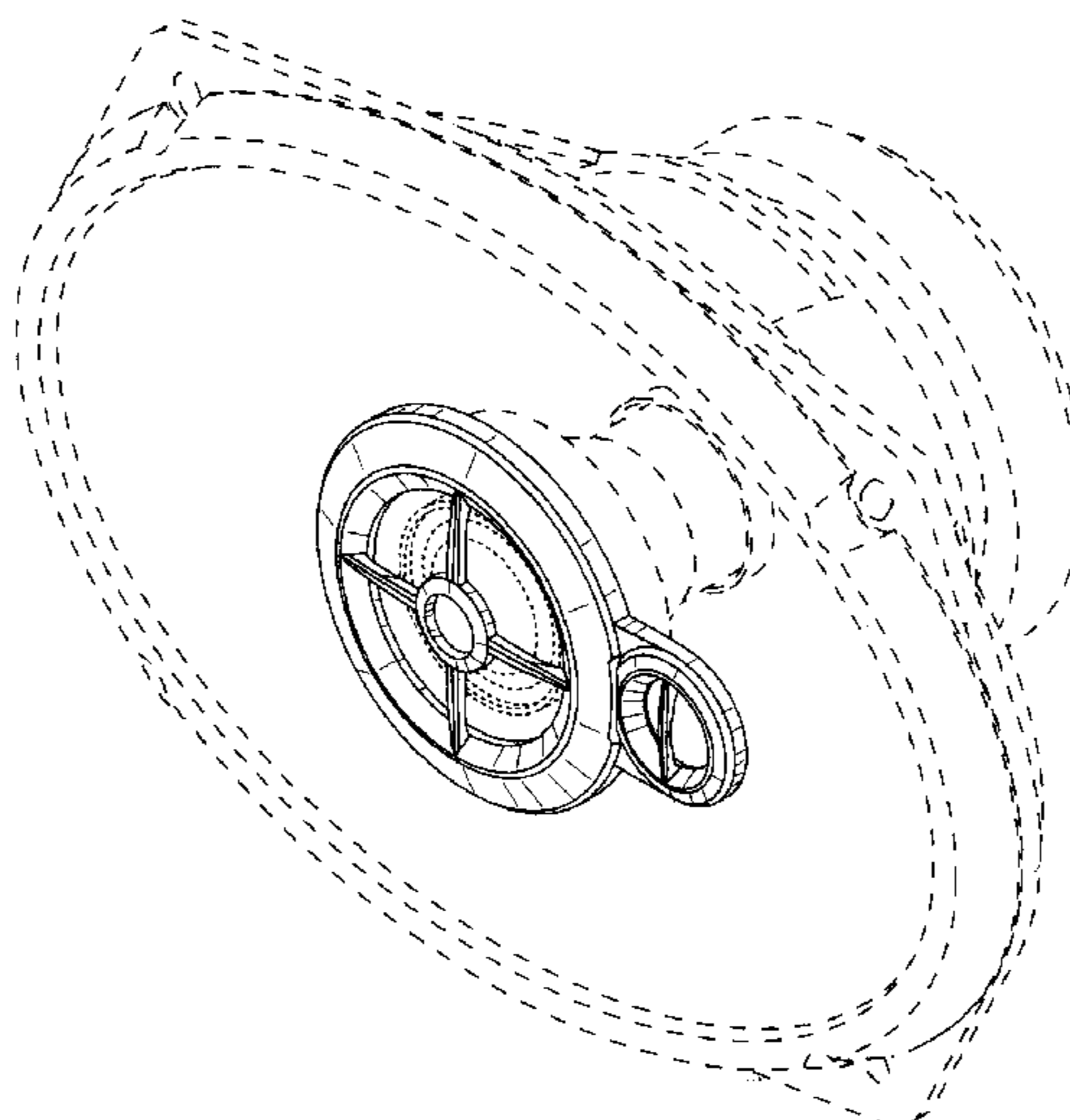

# US D550,207 S

Page 2

---

## U.S. PATENT DOCUMENTS

D451,908 S 12/2001 Mackie et al.  
D465,780 S 11/2002 Shindo  
D472,545 S 4/2003 Iijima et al.  
D480,070 S 9/2003 Hakoda  
D480,710 S 10/2003 Rivera  
D506,748 S 6/2005 Garretson et al.  
D506,992 S 7/2005 Suzuki  
D506,993 S 7/2005 Suzuki  
D507,560 S 7/2005 Sugiyama  
D509,213 S 9/2005 Hasbrook  
D510,084 S 9/2005 Hasbrook

## FOREIGN PATENT DOCUMENTS

JP D1159674 12/2002  
JP D1191947 12/2003  
JP D1191948 12/2003  
JP D1192160 12/2003

JP D1192162 12/2003  
JP D1193799 1/2004  
JP D1201052 4/2004  
JP D1201607 4/2004  
JP D1223330 11/2004  
JP D1223331 11/2004  
JP D1241403 6/2005  
JP D1241405 6/2005  
JP D1244078 6/2005  
JP D1244110 6/2005  
JP D1245202 7/2005  
JP D1247477 8/2005  
JP D1247478 8/2005  
JP D1247584 8/2005  
JP D1247585 8/2005  
JP D1256577 11/2005  
JP D1256578 11/2005

\* cited by examiner

FIG. 1

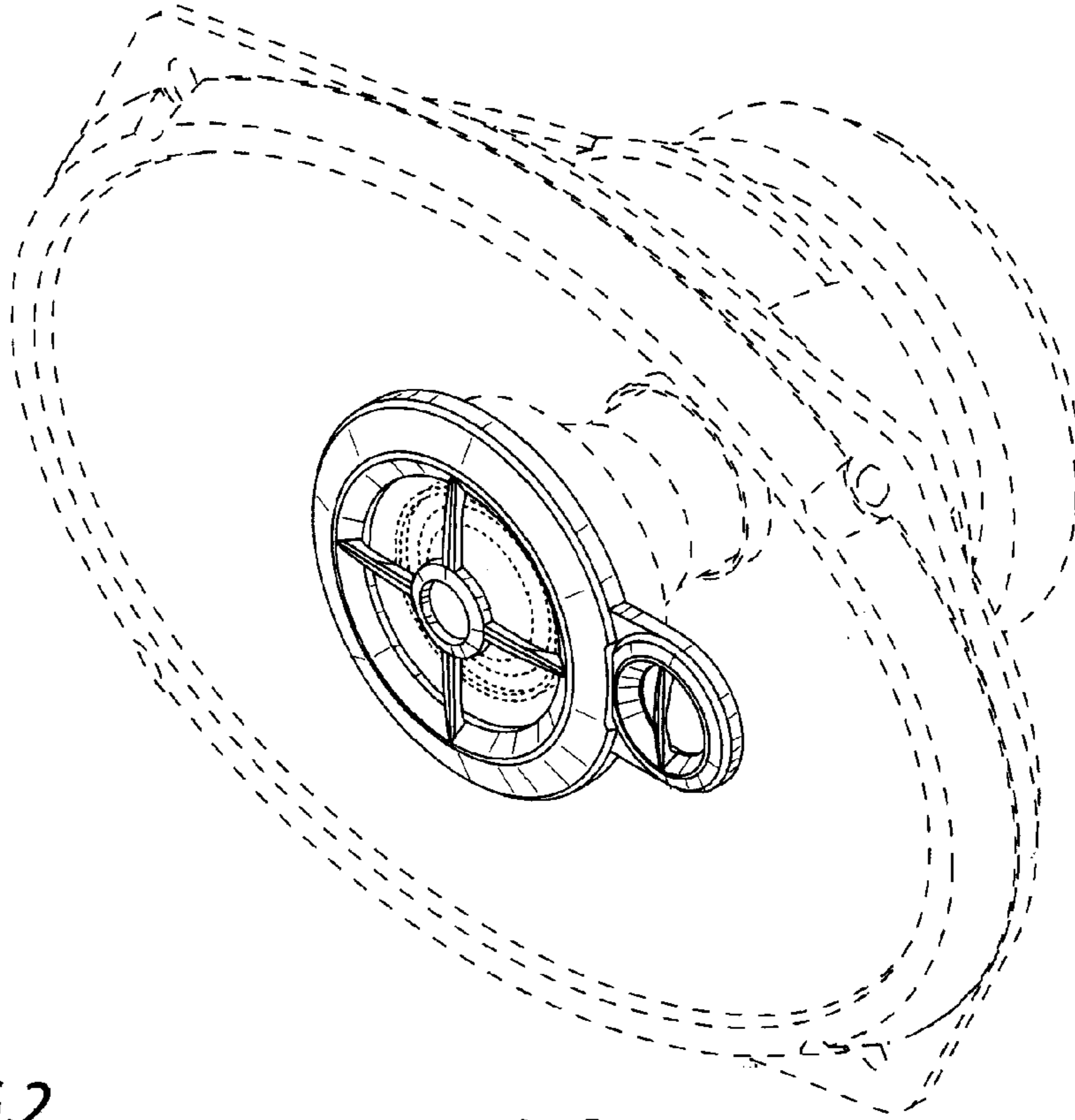

FIG. 2

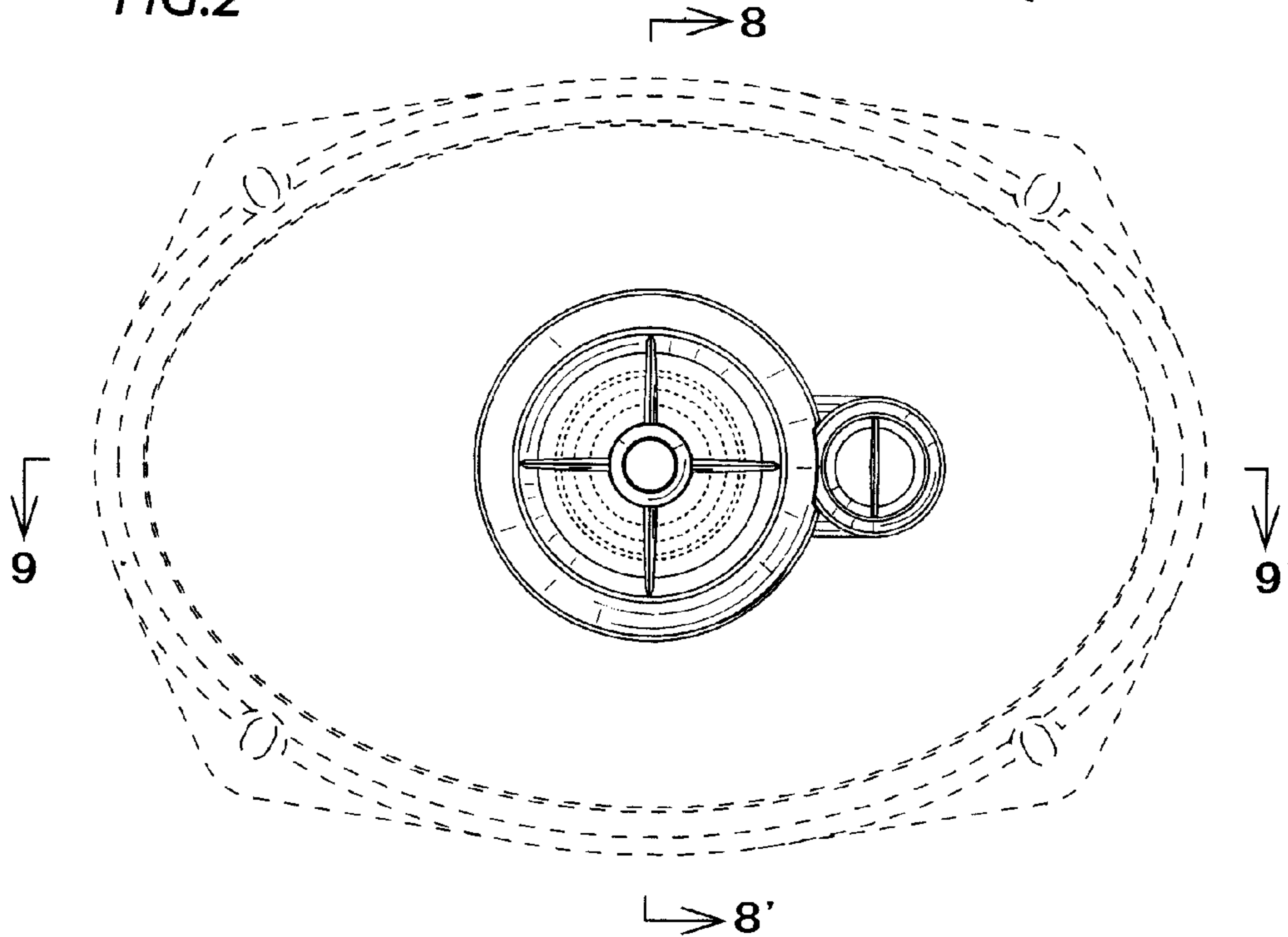

FIG.3

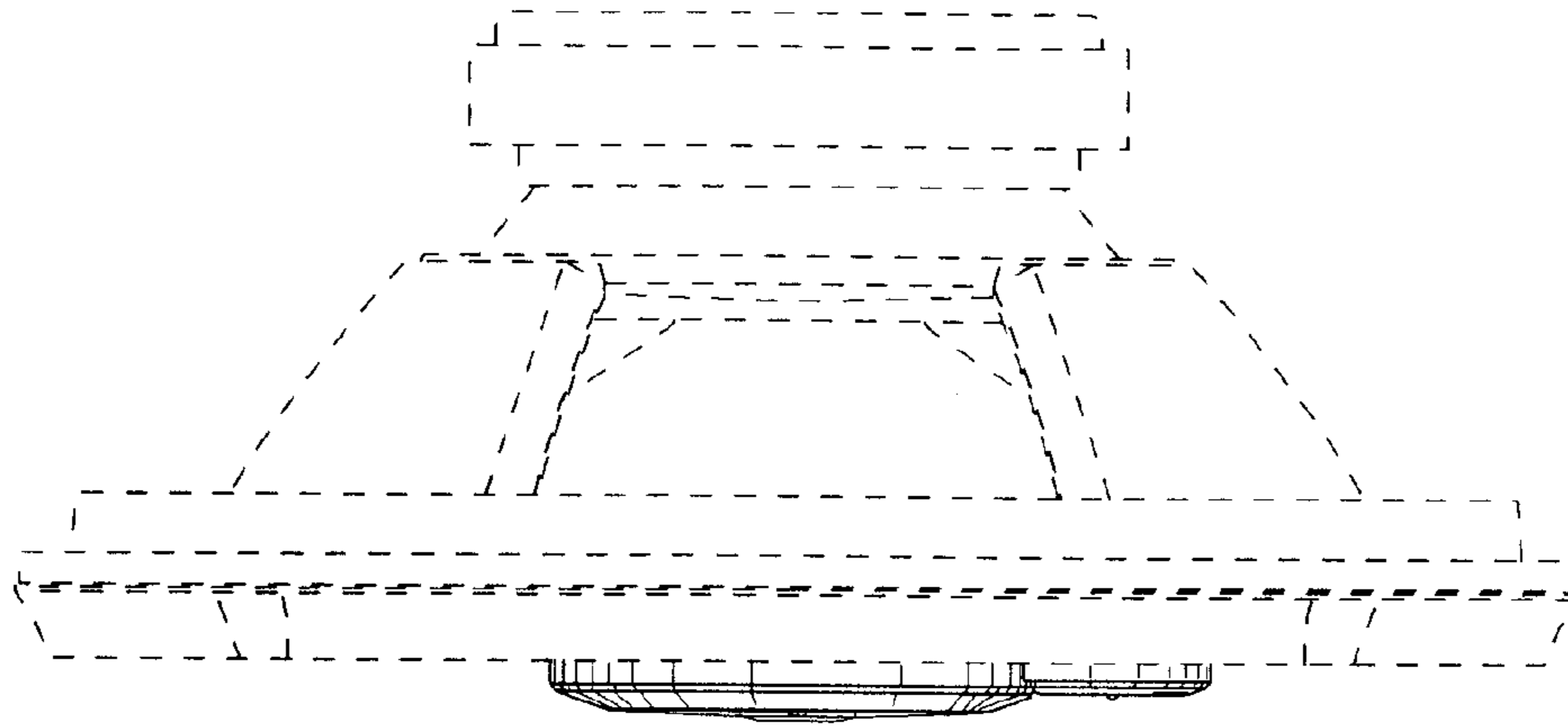

FIG.4

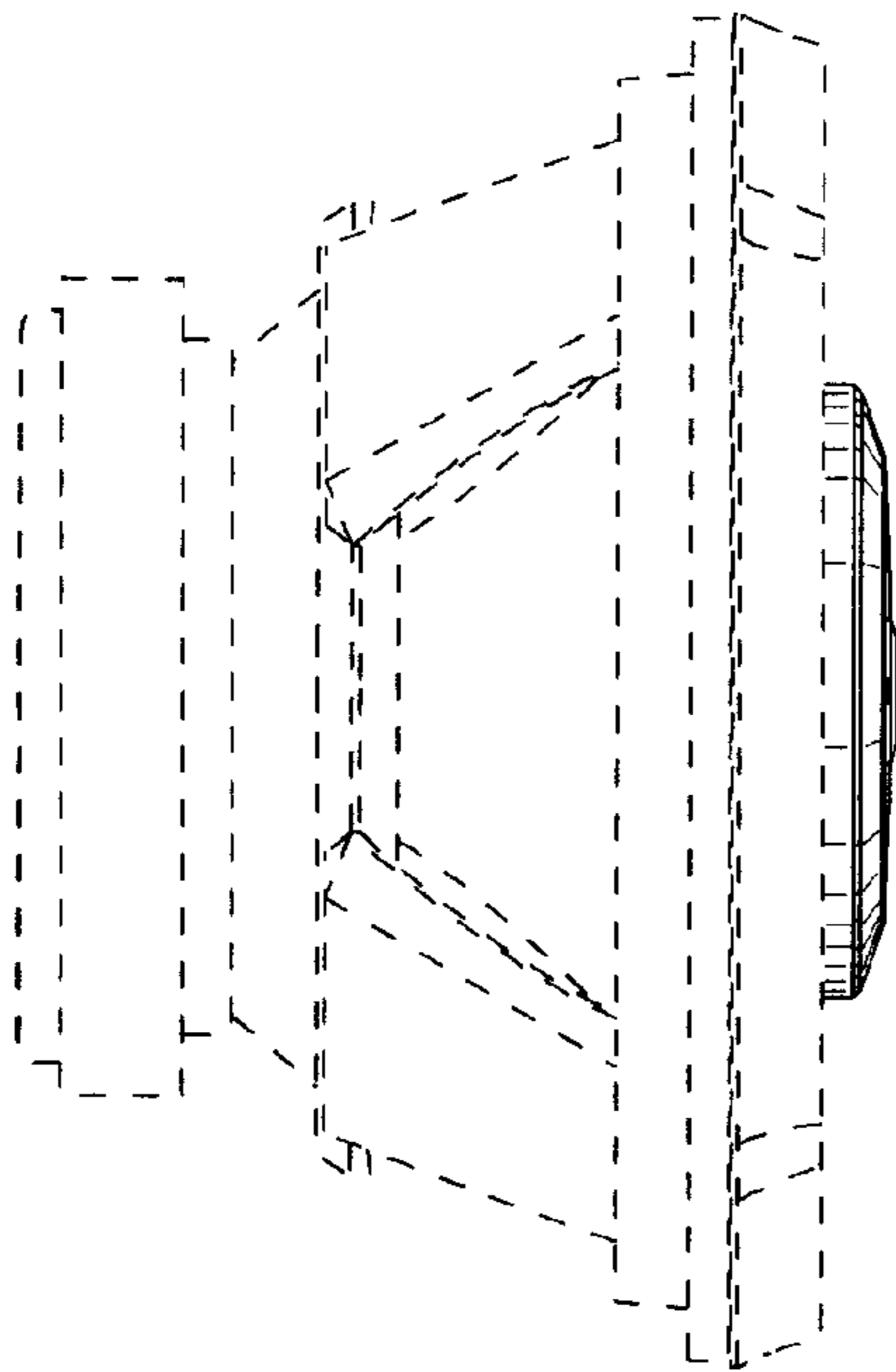
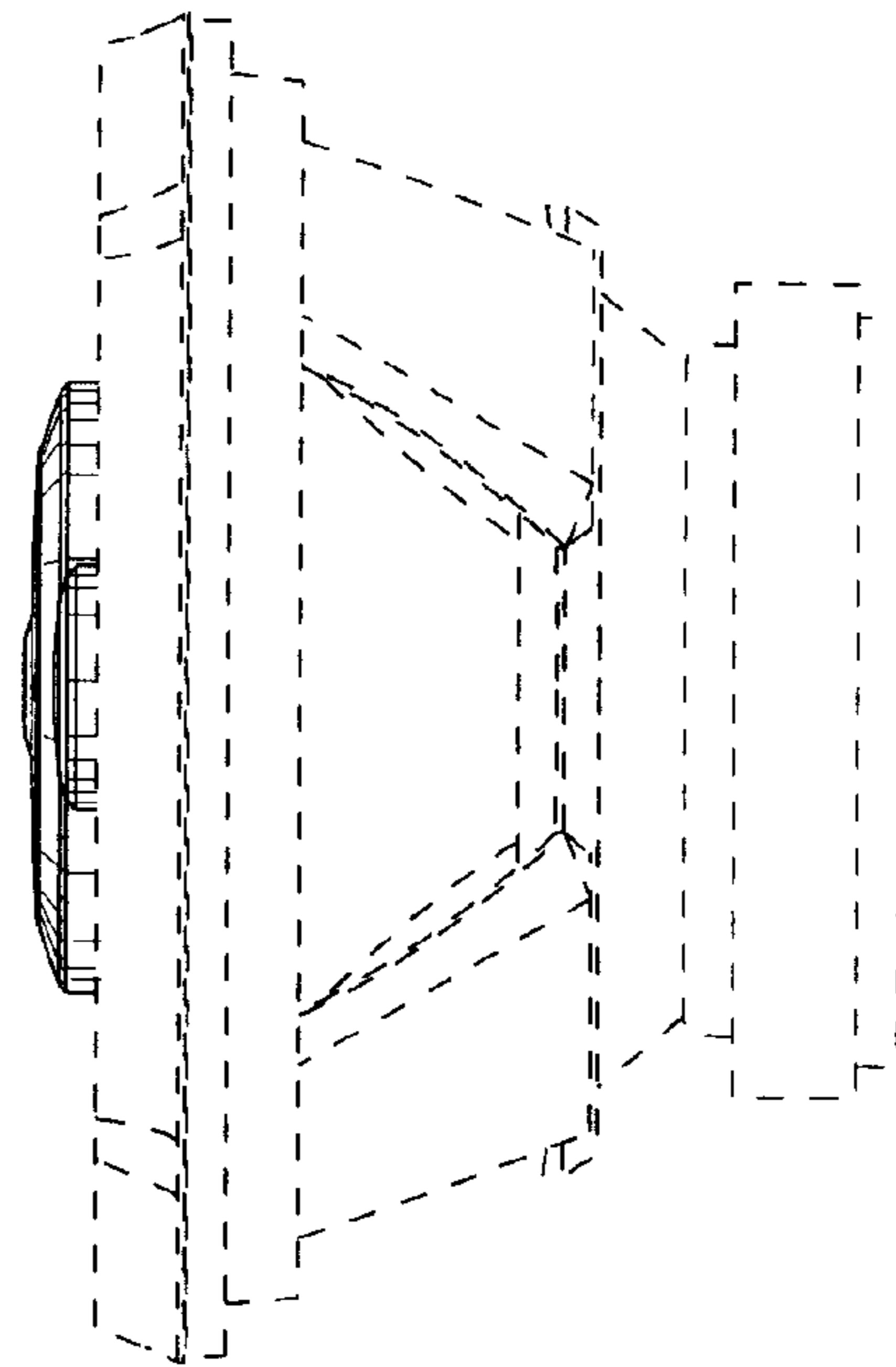
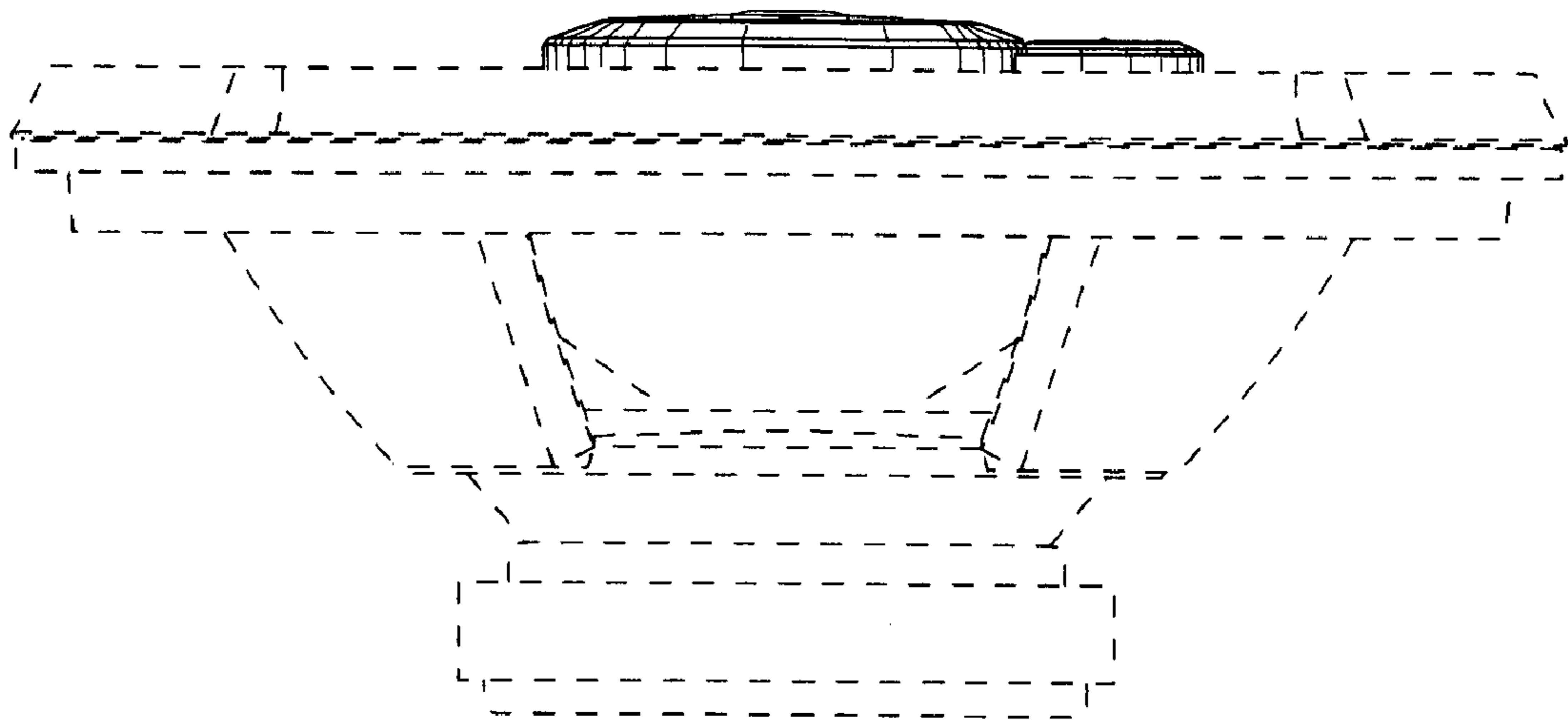

FIG.5



*FIG.6*



*FIG.7*

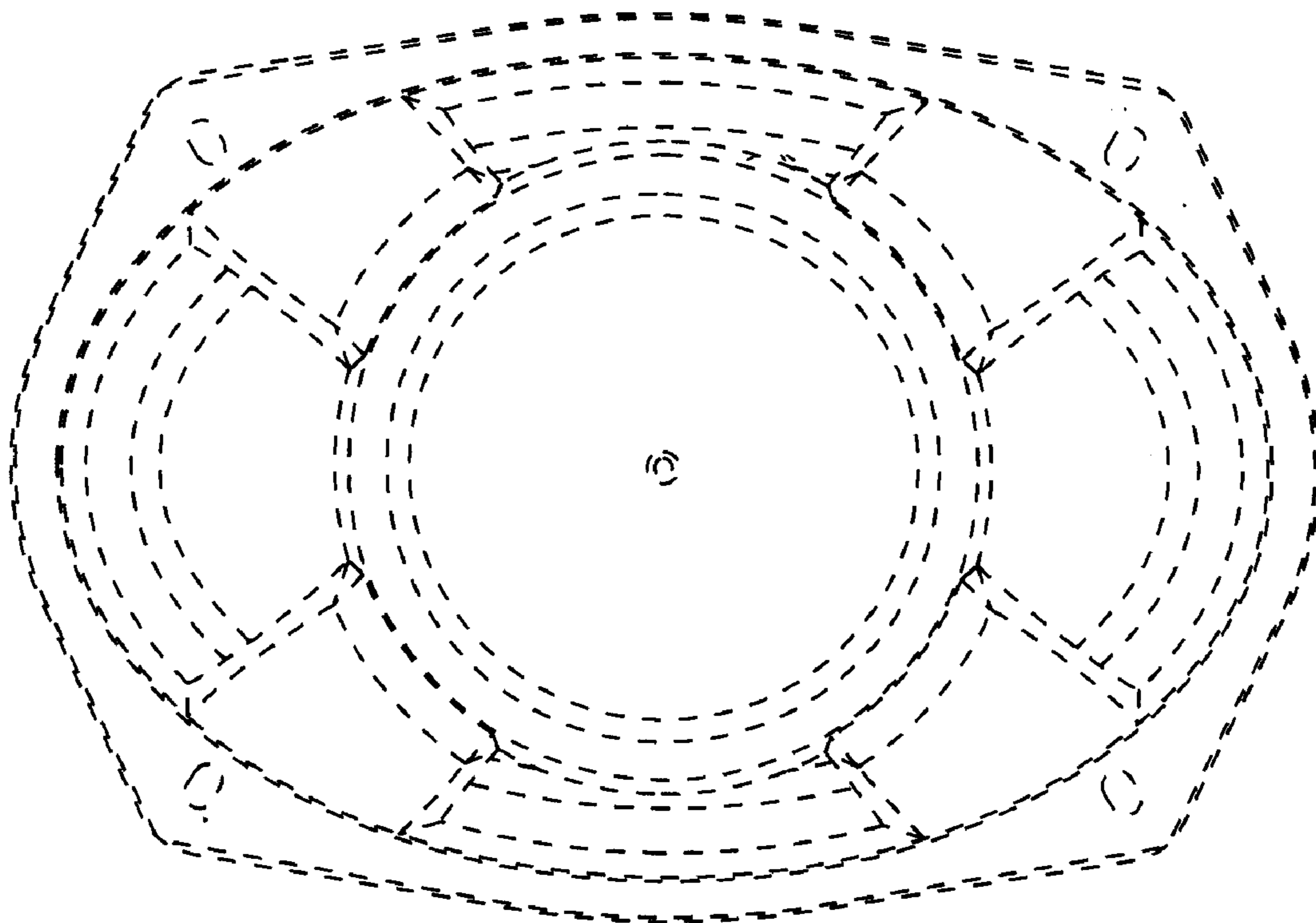

FIG.8

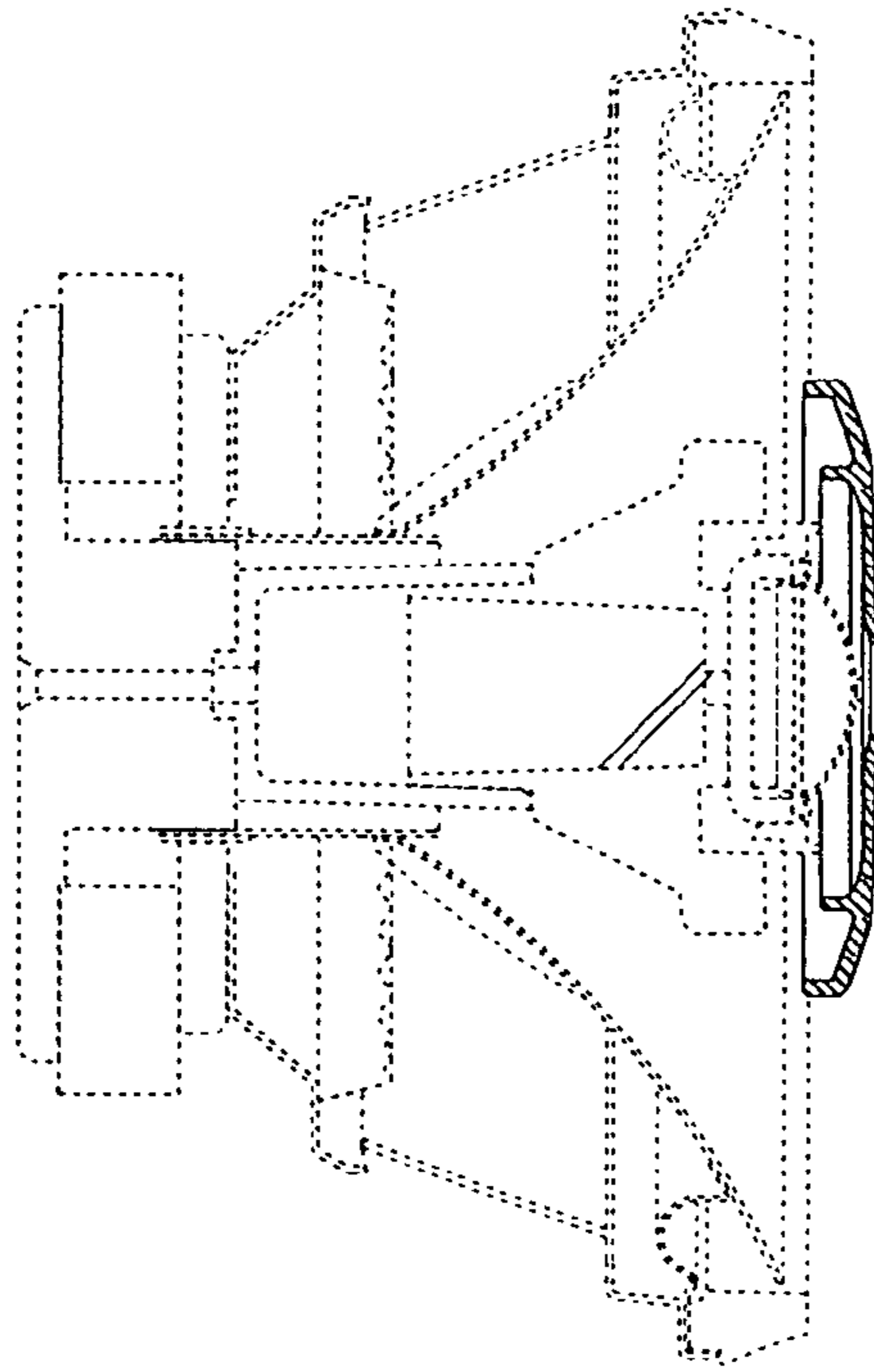

FIG.9

