

US00D550135S

(12) **United States Design Patent**  
**McChesney et al.**

(10) **Patent No.:** **US D550,135 S**

(45) **Date of Patent:** **\*\* Sep. 4, 2007**

(54) **AUTOMOTIVE QUARTER PANEL**

(75) Inventors: **Mark McChesney**, Saline, MI (US);  
**James Kuo**, Farmington, MI (US);  
**Patrick Schiavone**, Birmingham, MI  
(US); **Chelsia Lau**, Ann Arbor, MI  
(US)

(73) Assignee: **Ford Global Technologies, LLC**,  
Dearborn, MI (US)

(\*\*) Term: **14 Years**

(21) Appl. No.: **29/225,433**

(22) Filed: **Mar. 15, 2005**

(51) **LOC (8) Cl.** ..... **12-16**

(52) **U.S. Cl.** ..... **D12/196; D12/184**

(58) **Field of Classification Search** ..... D12/196,  
D12/98, 15, 14, 184; 296/183.1, 21, 24.3,  
296/24.43

See application file for complete search history.

(56) **References Cited**

**U.S. PATENT DOCUMENTS**

D503,912 S	*	4/2005	Metros et al.	.....	D12/184
D509,778 S	*	9/2005	Minami	.....	D12/184
D542,200 S	*	5/2007	Levy	.....	D12/184

**OTHER PUBLICATIONS**

<http://www.fordvehicles.com/suvs/explorersporttrac/>, Ford  
Vehicles: 2005 Ford Explorer Sport Trac—See pricing details, SUV  
options, packages and more, 16 pages.

\* cited by examiner

*Primary Examiner*—Melody N. Brown

(74) *Attorney, Agent, or Firm*—Frank A. MacKenzie;  
Brooks Kushman P.C.

(57) **CLAIM**

The ornamental design for an automotive quarter panel, as  
shown and described.

**DESCRIPTION**

FIG. 1 is a right side perspective view of an automotive  
quarter panel showing our new design;

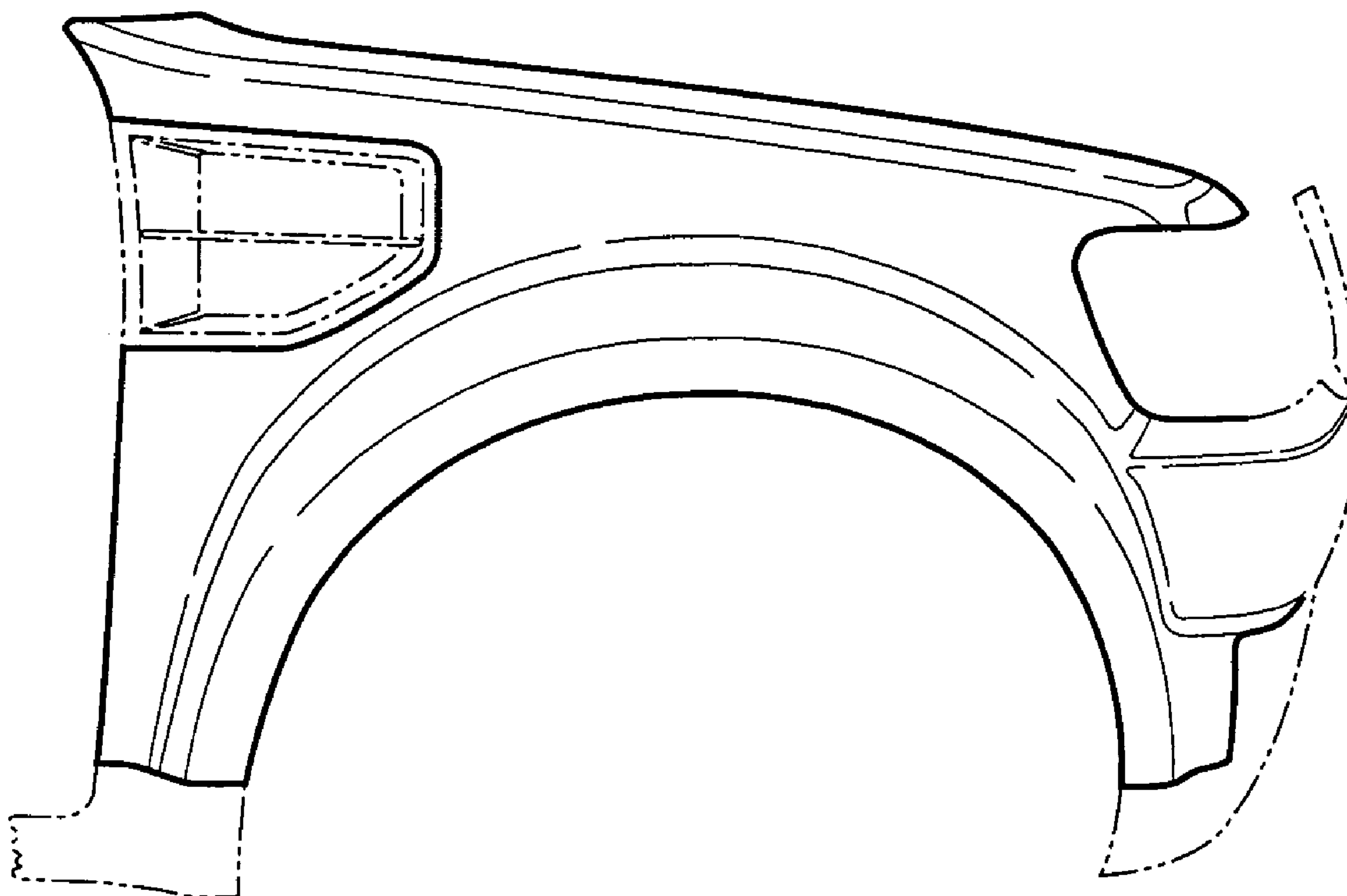
FIG. 2 is a right side elevation view thereof;

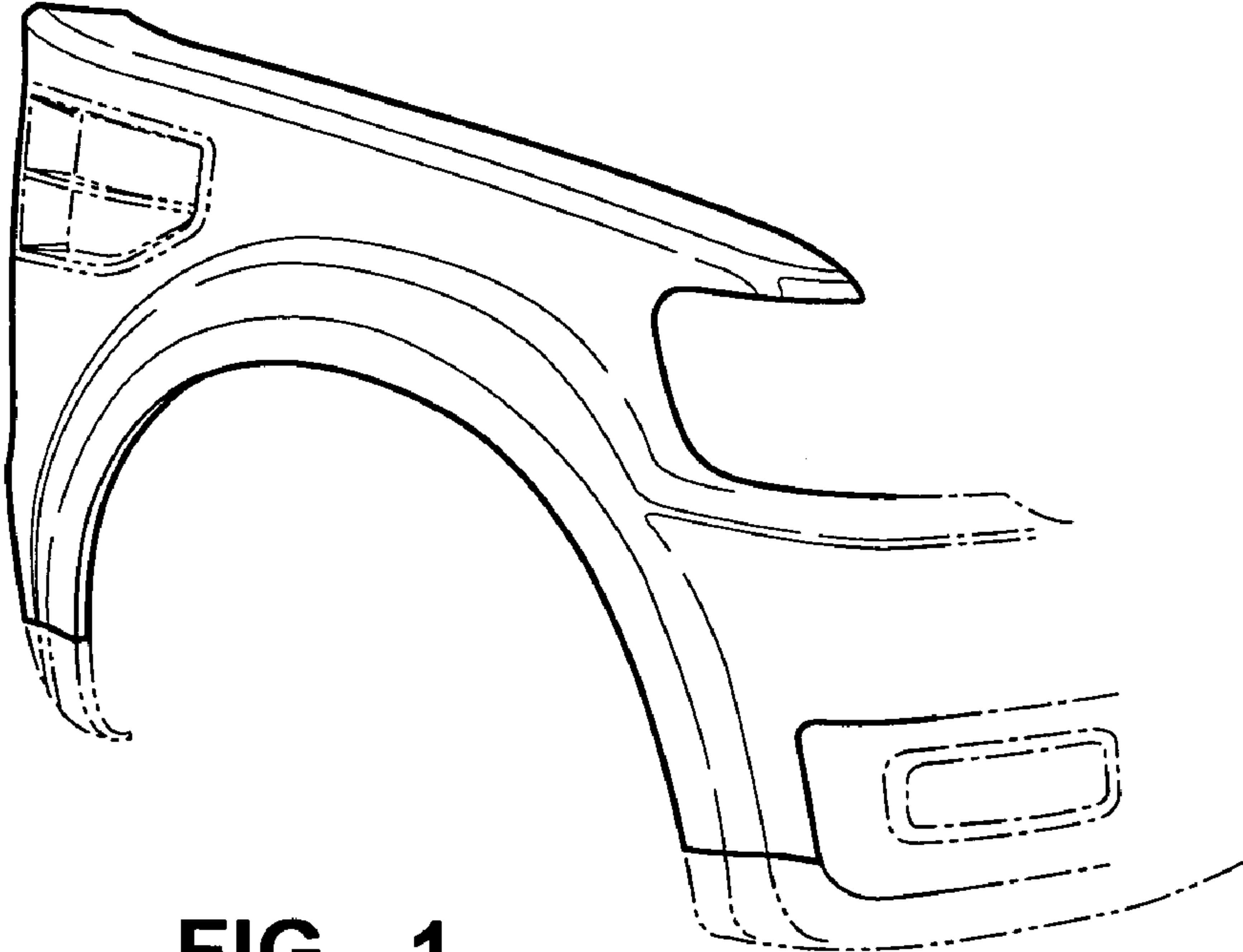
FIG. 3 is a right side perspective view of an automotive  
quarter panel showing a second embodiment of our new;  
and,

FIG. 4 is a right side elevation view of FIG. 3.

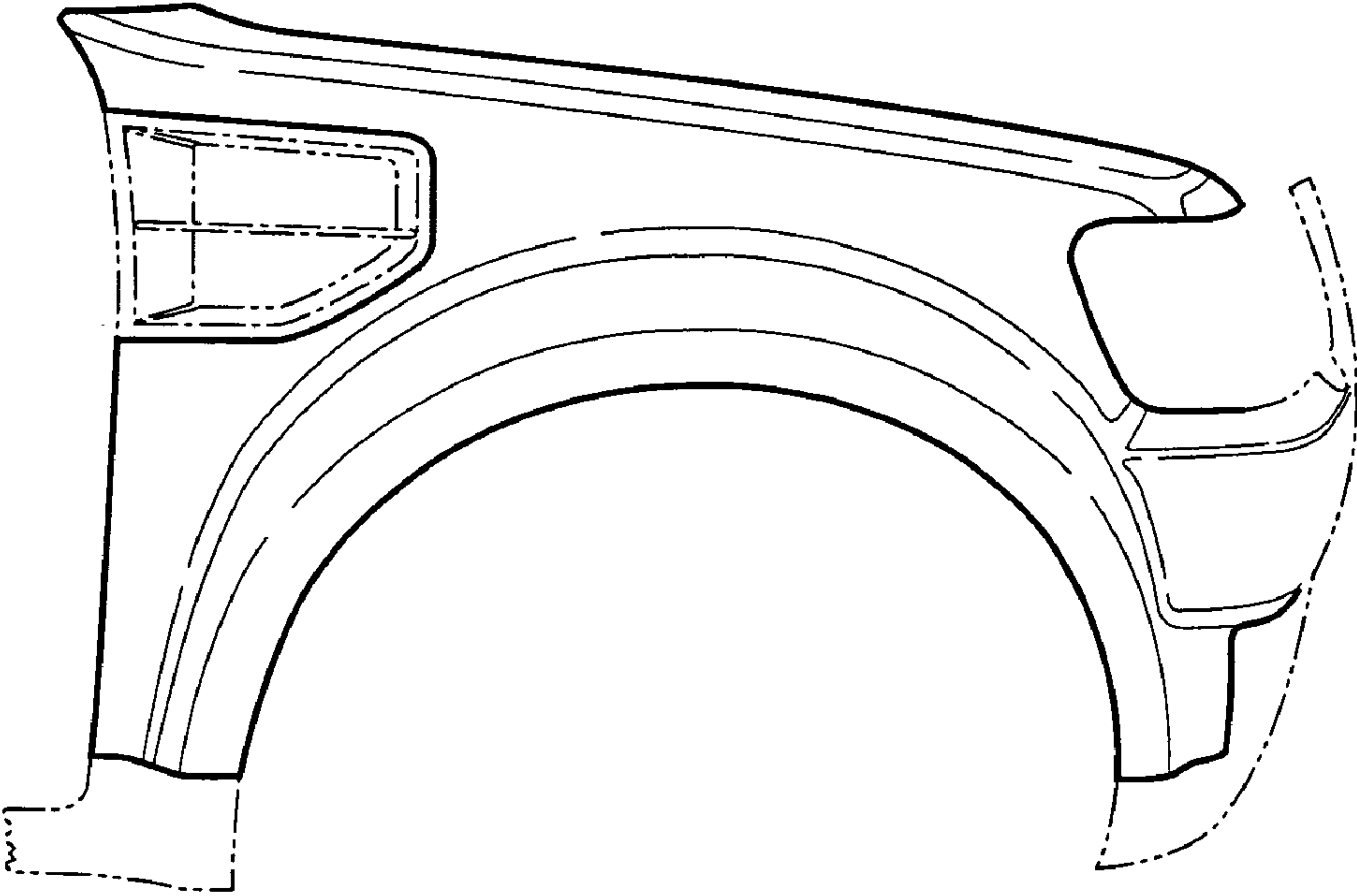
The broken lines are for illustrative purposes only and form  
no part of the claimed design.

**1 Claim, 2 Drawing Sheets**

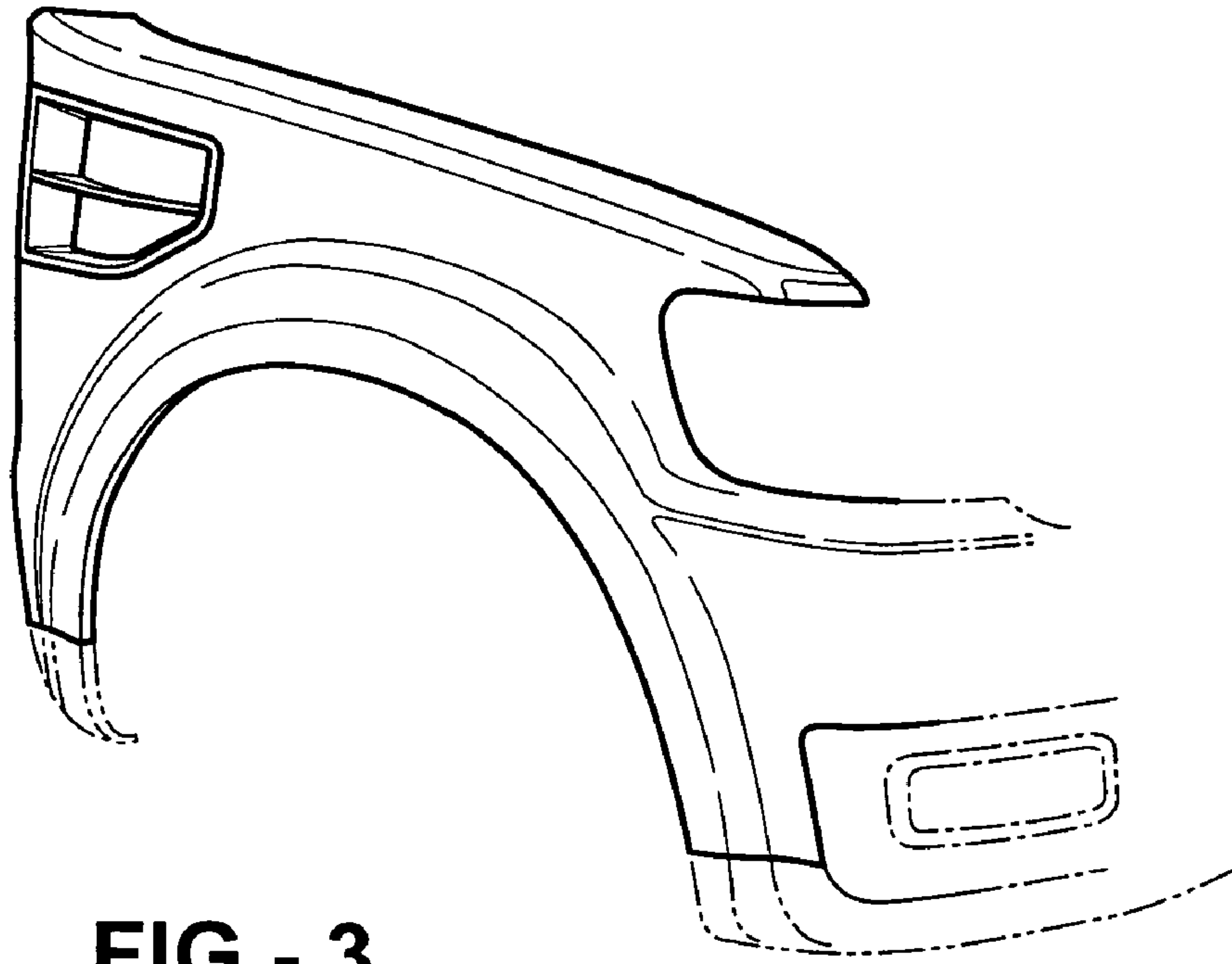




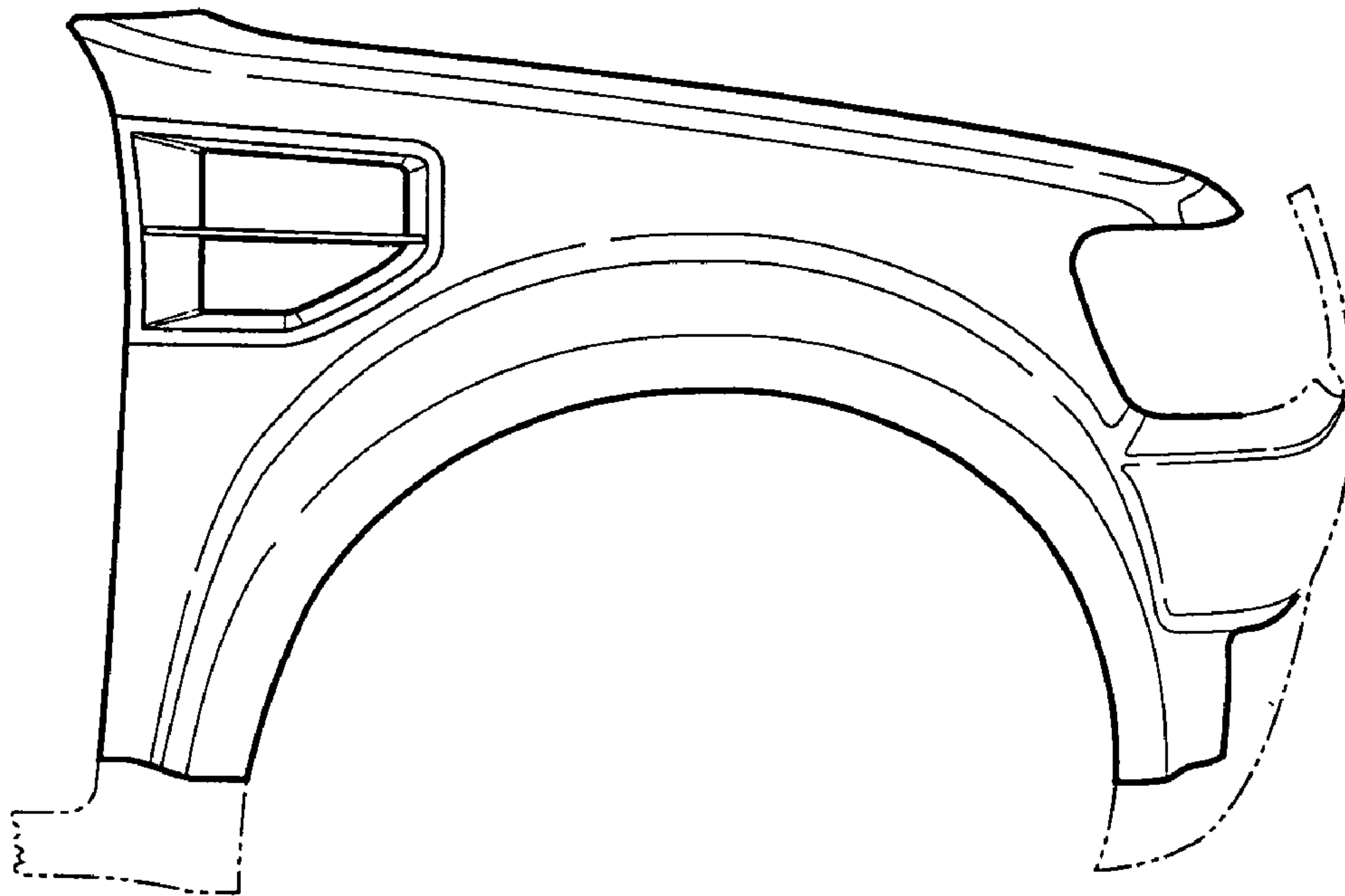
**FIG - 1**



**FIG - 2**



**FIG - 3**



**FIG - 4**