

US00D549754S

(12) **United States Design Patent**
Timhagen

(10) **Patent No.:** **US D549,754 S**

(45) **Date of Patent:** **** Aug. 28, 2007**

(54) **FLEXIBLE MODULE FOR AUTOMATION**

(75) Inventor: **Tommy Timhagen**, Bredaryd (SE)

(73) Assignee: **Animex AB** (SE)

(**) Term: **14 Years**

(21) Appl. No.: **29/239,916**

(22) Filed: **Oct. 4, 2005**

(51) **LOC (8) Cl.** **15-99**

(52) **U.S. Cl.** **D15/199**

(58) **Field of Classification Search** D15/199;
D25/1, 61, 138; 52/578, 648.1, 653.1; 160/38,
160/89, 371

See application file for complete search history.

(56) **References Cited**

U.S. PATENT DOCUMENTS

D255,122	S	*	5/1980	Mahl	D15/199
4,304,224	A	*	12/1981	Fortney	600/21
D299,891	S	*	2/1989	Belszek	D25/1
4,884,376	A	*	12/1989	DeBlock et al.	52/92.2
D336,136	S	*	6/1993	Foster	D25/1
7,150,127	B2	*	12/2006	Underwood et al.	52/36.1
2003/0004594	A1	*	1/2003	Liu et al.	700/95
2004/0226257	A1	*	11/2004	Jaeger	52/749.1
2004/0255539	A1	*	12/2004	Beavers et al.	52/506.01
2006/0043111	A1	*	3/2006	Jennings et al.	222/129.1
2007/0016116	A1	*	1/2007	Reinkensmeyer et al.	601/5
2007/0033894	A1	*	2/2007	Underwood et al.	52/578

* cited by examiner

Primary Examiner—Antoine D. Davis

Assistant Examiner—Patricia Palasik

(74) *Attorney, Agent, or Firm*—Ostrolenk, Faber, Gerb & Soffen, LLP

(57) **CLAIM**

The ornamental design for a flexible module for automation, as shown and described.

DESCRIPTION

FIG. 1 is a perspective view of the module, seen from the front and slightly from above;

FIG. 2 is a perspective view of the module, seen from the rear and slightly from above;

FIG. 3 is a front elevation of the module;

FIG. 4 is a right side elevation of the module;

FIG. 5 is a rear elevation of the module;

FIG. 6 is a plan view of the underside of the module;

FIG. 7 is a plan view of the module as seen from above; and,

FIG. 8 is a left side elevation of the module.

A flexible module for automation, which together with other similar modules can form a workstation for an industrial robot, a so-called robot cell. The module comprises quick couplings for docking against a central part where the robot is placed.

1 Claim, 7 Drawing Sheets

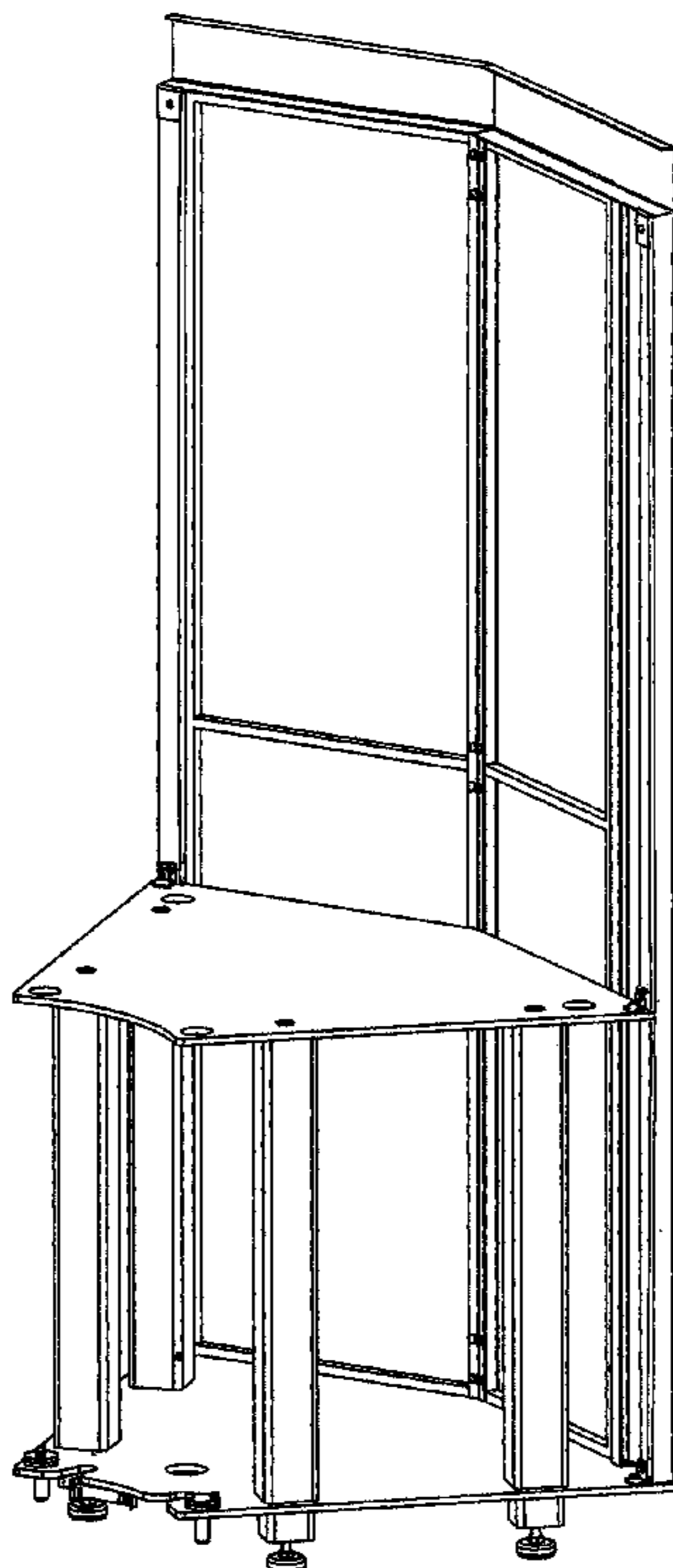

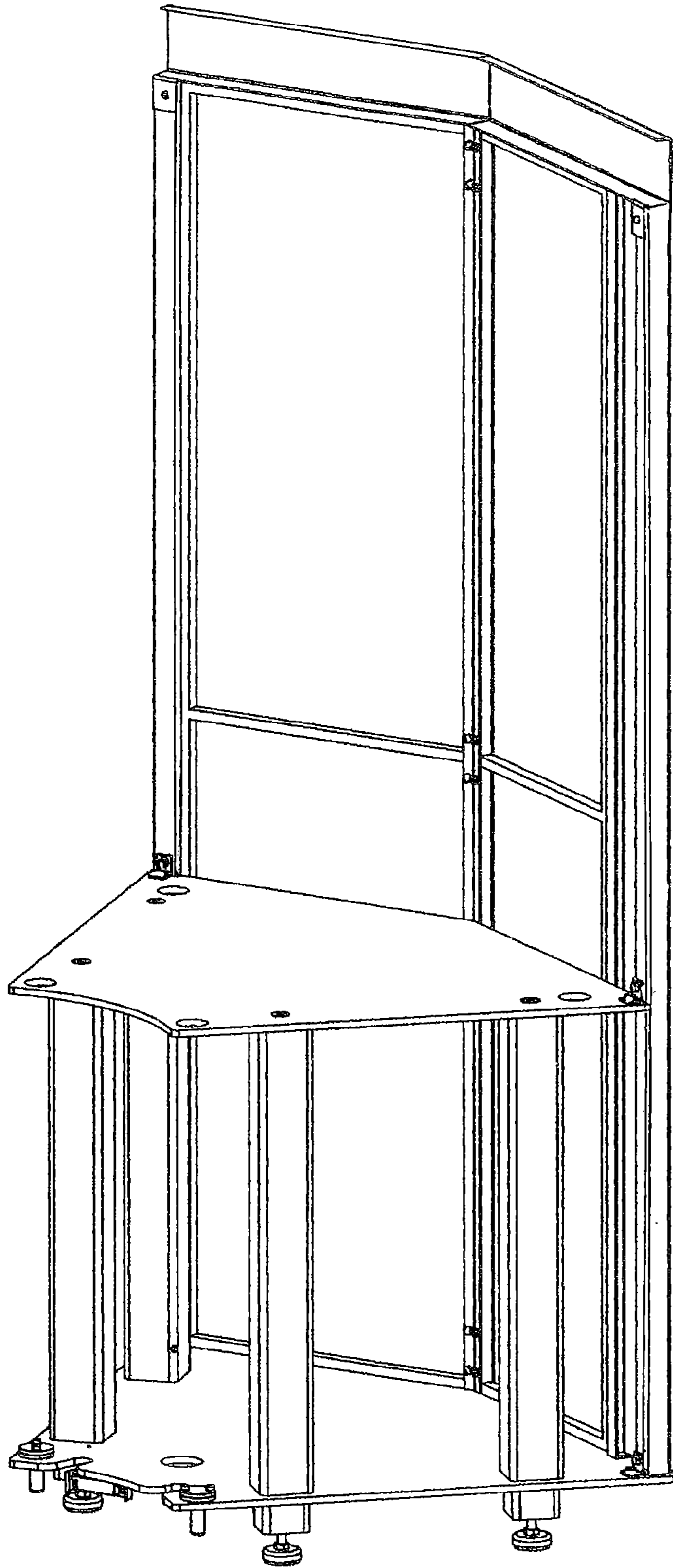

FIGURE 1

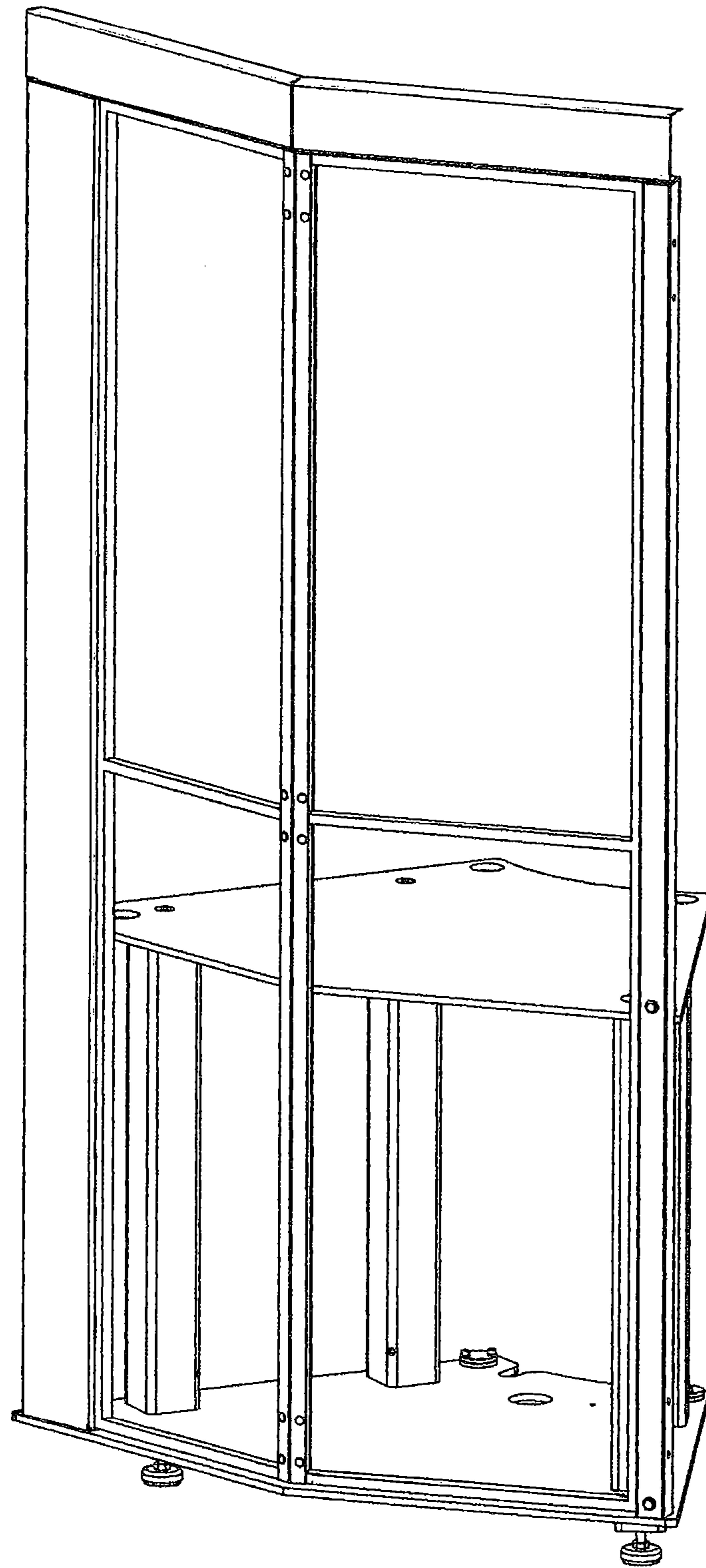

FIGURE 2

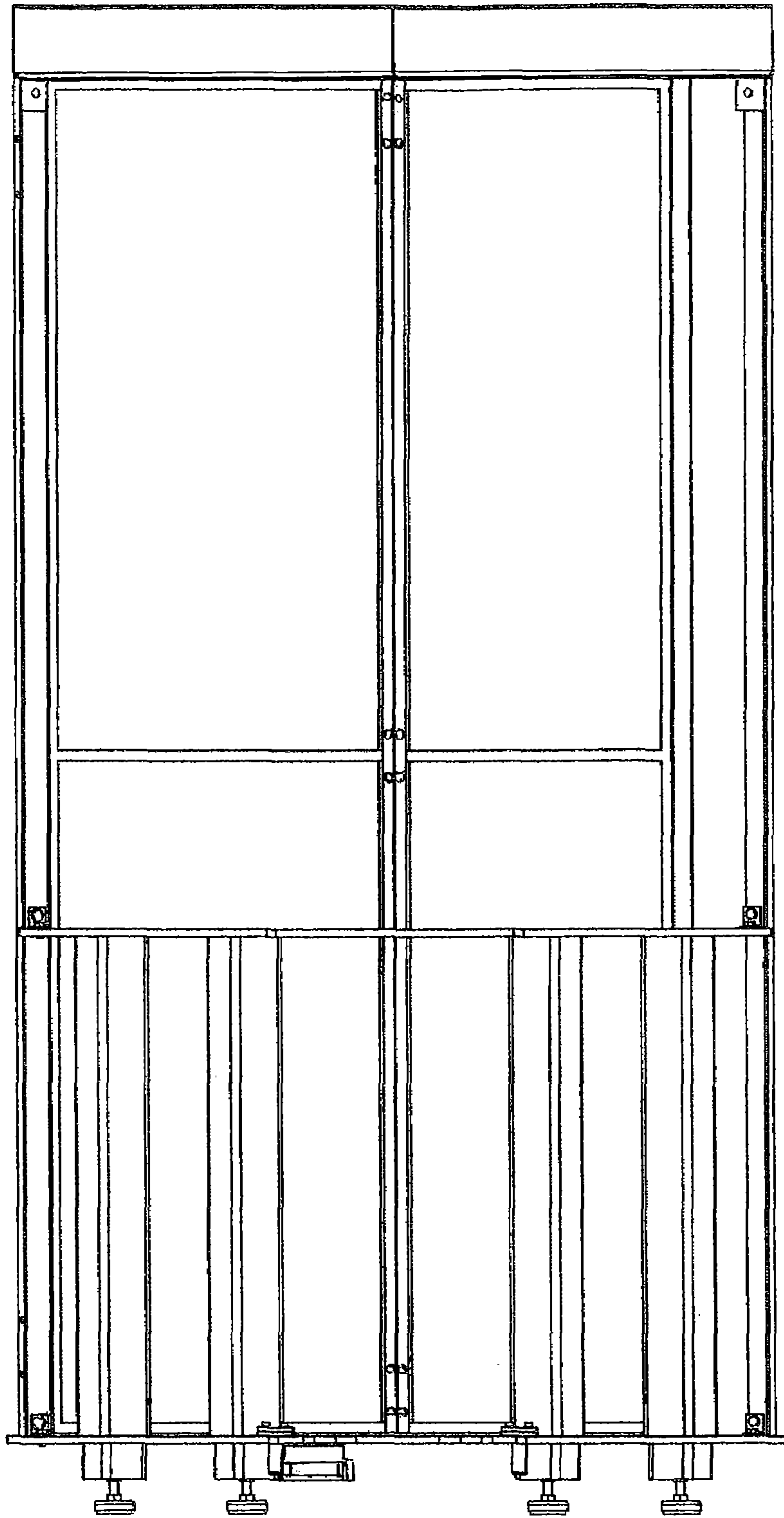

FIGURE 3

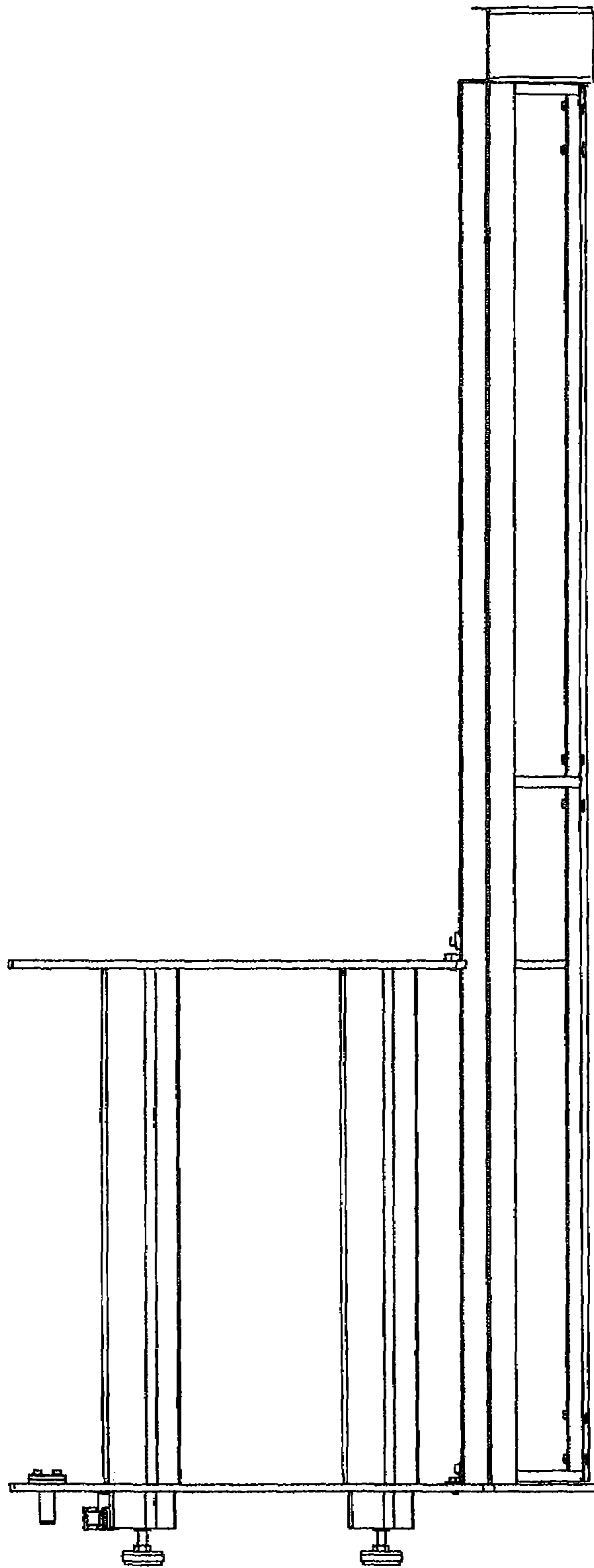

FIGURE 4

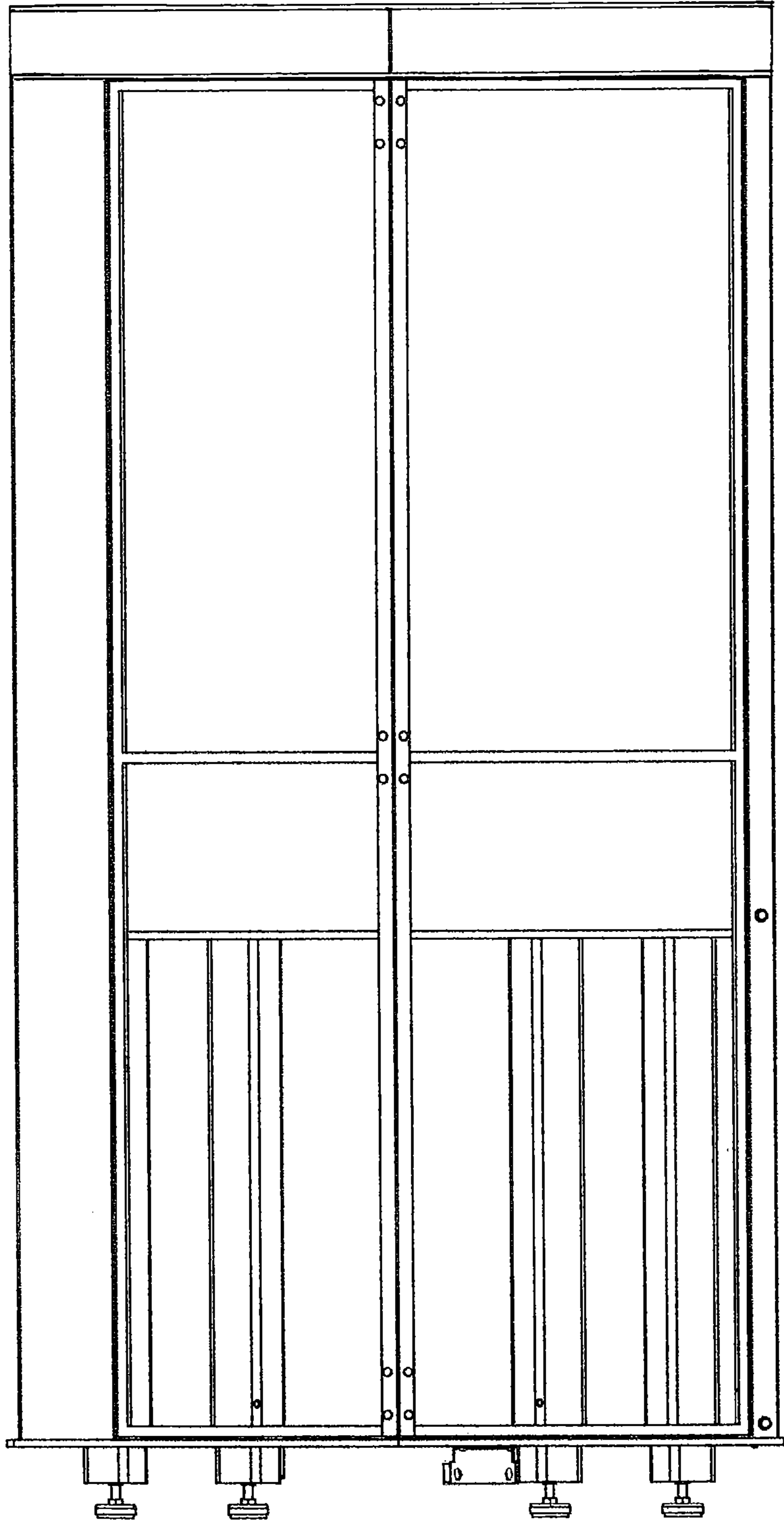

FIGURE 5

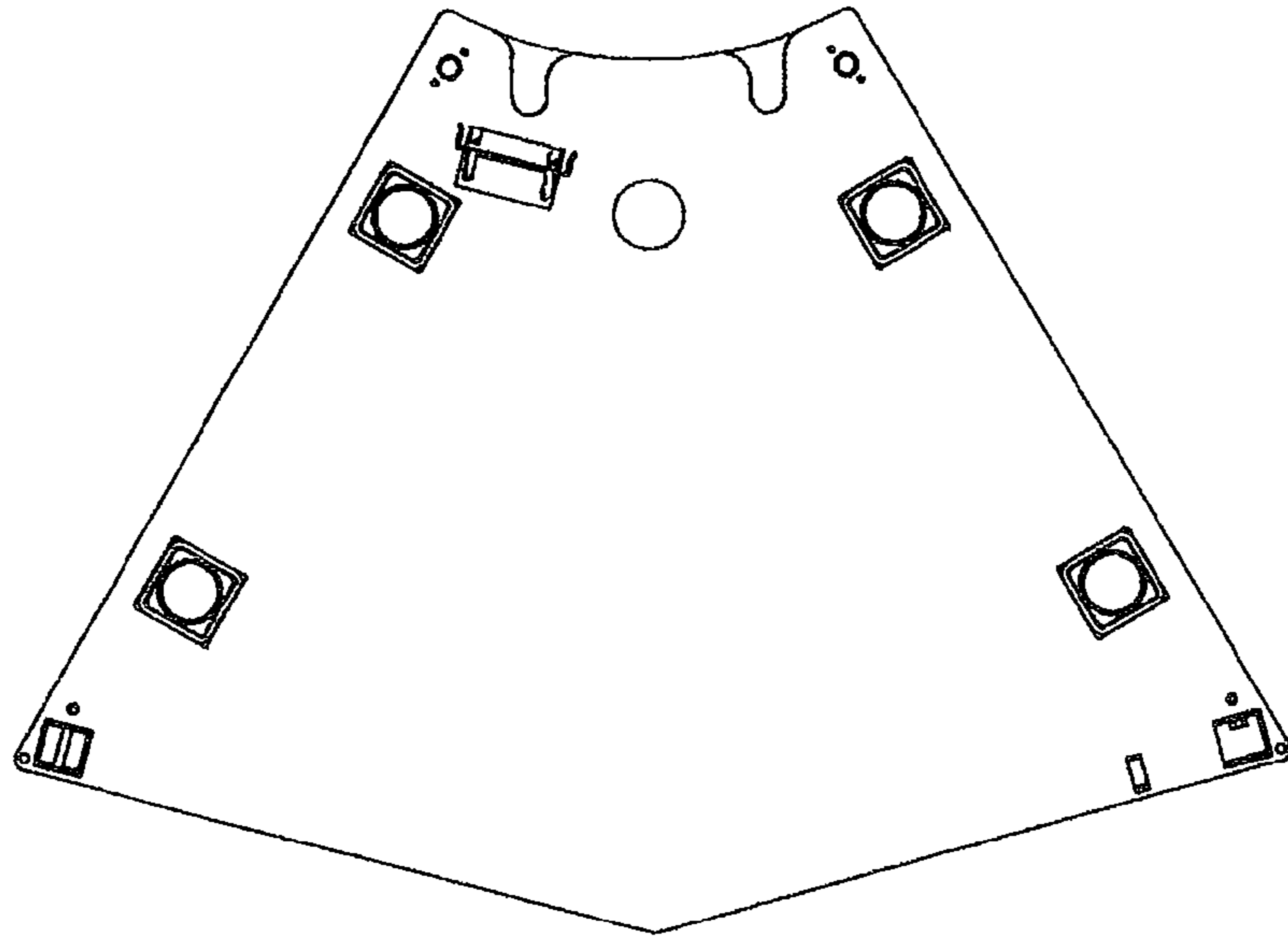

FIGURE 6

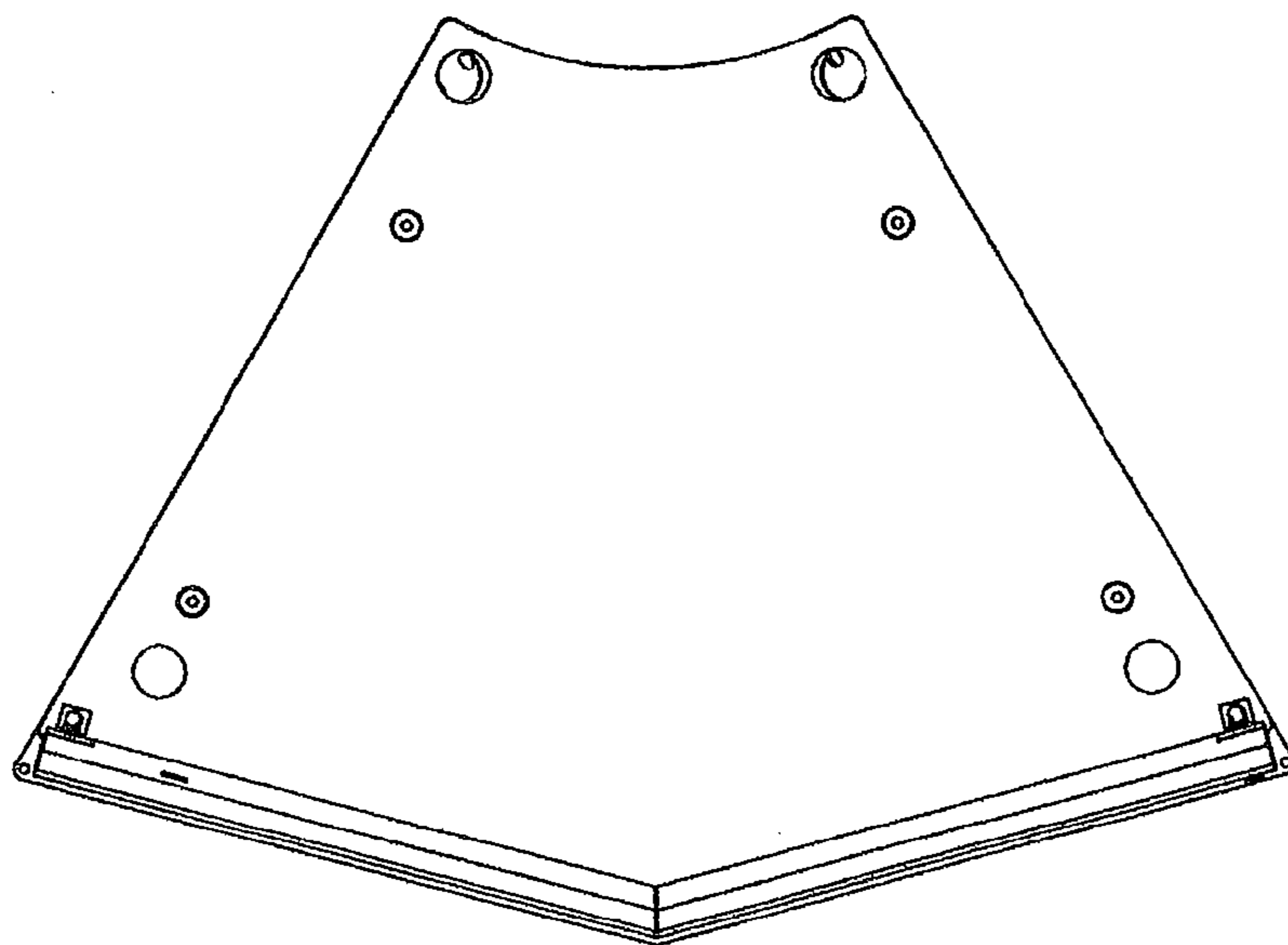

FIGURE 7

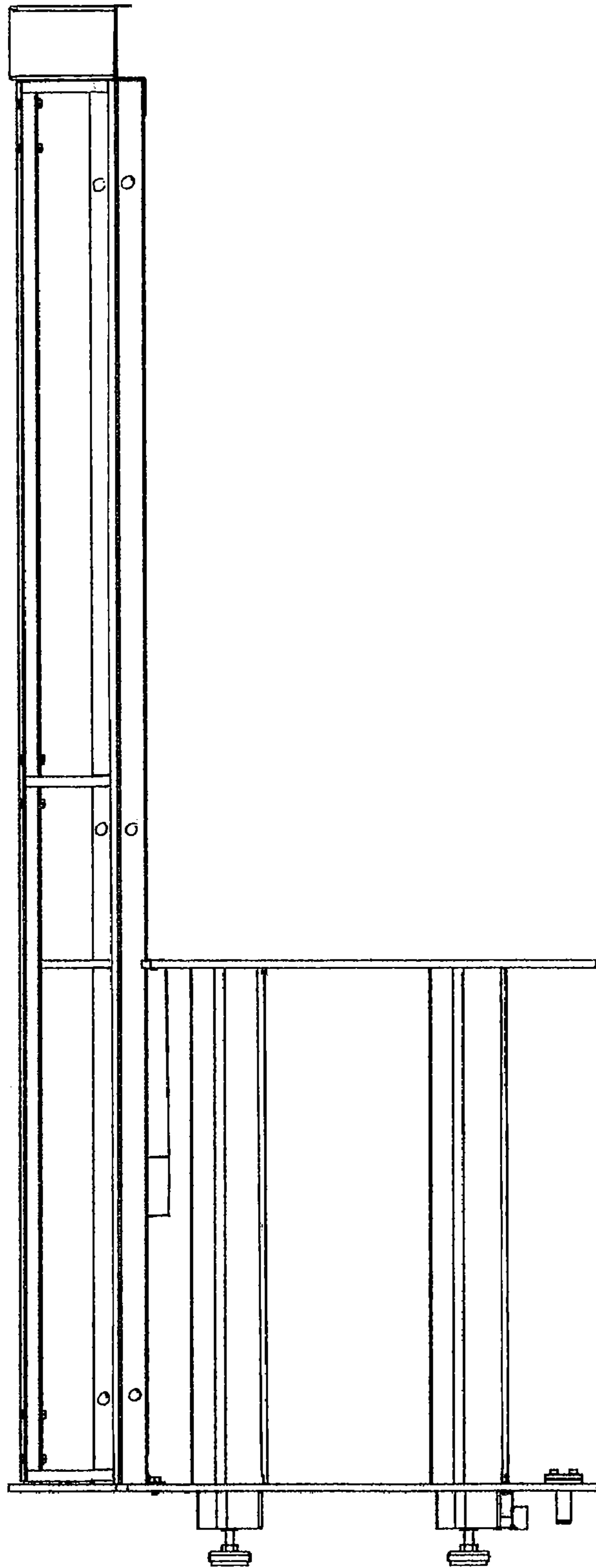

FIGURE 8