



(12) **United States Design Patent**
Hartikainen

(10) **Patent No.:** **US D549,550 S**
(45) **Date of Patent:** **** Aug. 28, 2007**

(54) **HELICOPTER SECURING COMPONENT KIT**

(75) Inventor: **Martti Hartikainen**, 1105 Fern Ridge Drive, Millbay, British Columbia (CA) V0R 2P2

(73) Assignee: **Martti Hartikainen**, Millbay, BC (CA)

(**) Term: **14 Years**

(21) Appl. No.: **29/259,687**

(22) Filed: **May 15, 2006**

(30) **Foreign Application Priority Data**

Nov. 16, 2005 (CA) 113512

(51) **LOC (8) Cl.** **08-07**

(52) **U.S. Cl.** **D8/330**

(58) **Field of Classification Search** D8/330-348;
114/261; 244/114-116, 17.17; 414/427,
414/495

See application file for complete search history.

(56) **References Cited**

U.S. PATENT DOCUMENTS

- 3,303,807 A * 2/1967 Stewart et al. 244/115 X
- 3,552,689 A * 1/1971 Baekken 244/115
- 4,420,132 A * 12/1983 Martin 244/115
- 5,248,115 A * 9/1993 Aurelio 244/115

* cited by examiner

Primary Examiner—Mitchell Siegel

(57) **CLAIM**

The ornamental design for a helicopter securing component kit, as shown and described.

DESCRIPTION

FIG. 1 is a front perspective view of the crew door lock component of the helicopter securing component kit of the present design illustrating the subcomponents in an open position.

FIG. 2 is a front perspective view of the crew door lock component illustrating the subcomponents in a closed open position.

FIG. 3 is a top planar view of the crew door lock component in a closed position.

FIG. 4 is a front elevation view of the crew door lock component in a closed position with the rear elevation view being a mirror image thereof.

FIG. 5 is a left side view of the crew door lock component in a closed position.

FIG. 6 is a left side elevation view of the cargo door lock component of the helicopter securing component kit of the present design illustrating the subcomponents in an open position.

FIG. 7 is a top planar view of the cargo door lock component illustrating the subcomponents in the open position.

FIG. 8 is a left side elevation view of the cargo door lock component illustrating the subcomponents in a closed position.

FIG. 9 is a left side perspective view of the cargo door lock component in a closed position illustrating an environment with which the cargo door lock component may be associated in broken lines.

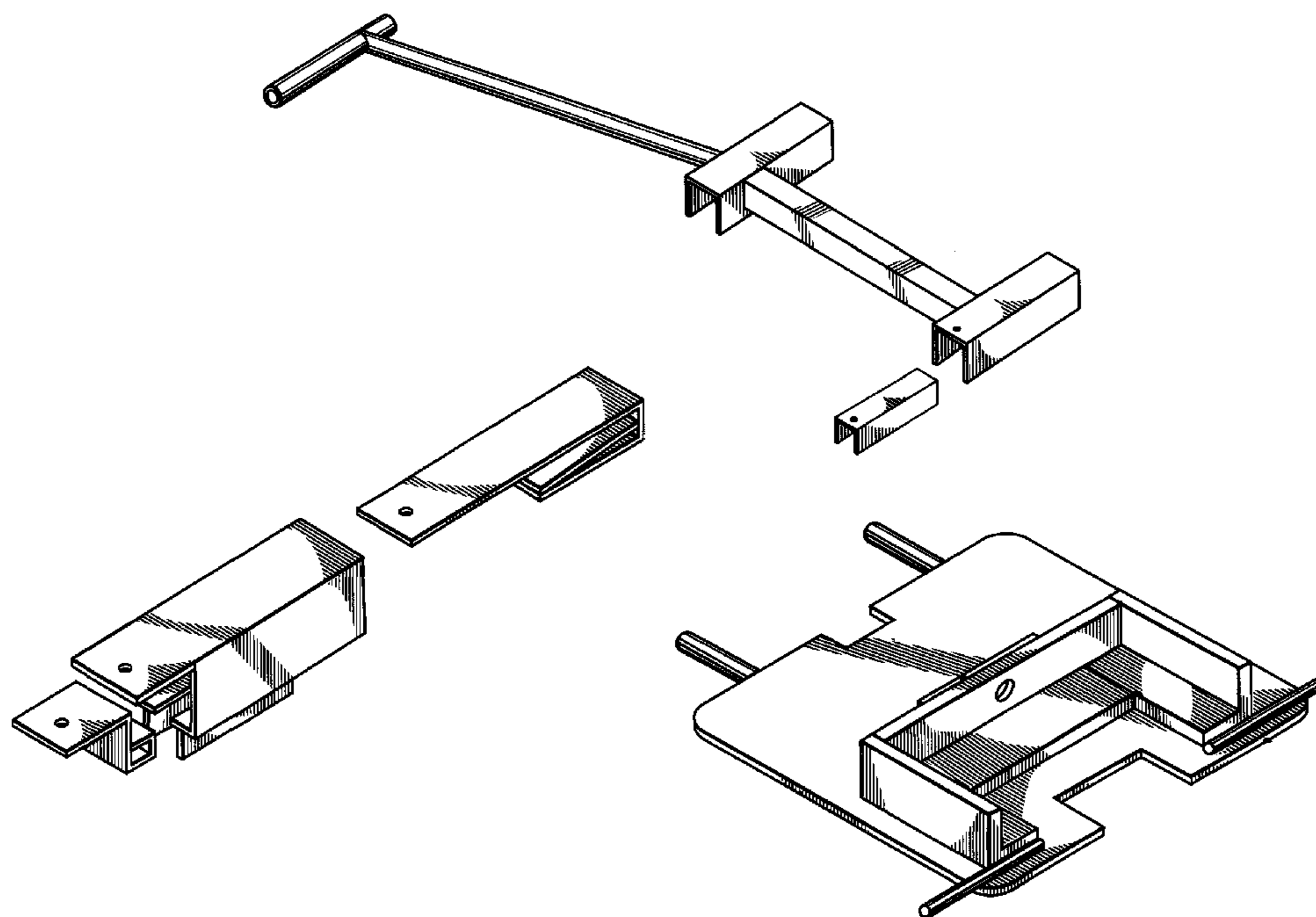

FIG. 10 is a front perspective view of a cargo door window lock component of the helicopter securing component kit of the present design.

FIG. 11 is a top planar view of the cargo door window lock component.

FIG. 12 is a bottom planar view of the cargo door window lock component.

FIG. 13 is a left side elevation view of the cargo door window lock component with the right side elevation view being a mirror image thereof.

FIG. 14 is a front elevation view of the cargo door window lock component.

FIG. 15 is a rear elevation view of the cargo door window lock component.

FIG. 16 is a left perspective view of the pop-up handle lock component of the helicopter securing component kit of the present design illustrating the subcomponents in an open position.

FIG. 17 is a left perspective view of the pop-up handle lock component illustrating the subcomponents in a closed position.

FIG. 18 is a bottom planar view of the pop-up handle lock component in a closed position.

FIG. 19 is a top planar view of the pop-up handle lock component in a closed position.

FIG. 20 is a left side elevation view of the pop-up handle lock component in a closed position with the right side elevation view being a mirror image thereof.

FIG. 21 is a front elevation view of the pop-up handle lock component in a closed position.

FIG. 22 is a back perspective view of the ebay lock component of the helicopter securing component kit of the present design illustrating the subcomponents in an open position.

FIG. 23 is a back perspective view of the ebay lock component illustrating the subcomponents in a closed position.

FIG. 24 is a left side elevation view of the ebay lock component in a closed position.

FIG. 25 is a rear elevation view of the ebay lock component in a closed position.

FIG. 26 is a front elevation view of the ebay lock component in a closed position.

FIG. 27 is a top planar view of the ebay lock component in a closed position.

FIG. 28 is a bottom planar view of the ebay lock component in a closed position.

FIG. 29 is a left front perspective view of the fuel tank lock component of the helicopter securing component kit of the present design illustrating the subcomponents in an open position.

FIG. 30 is a left front perspective view of the fuel tank lock component illustrating the subcomponents in closed position.

FIG. 31 is a top planar view of the fuel tank lock component in a closed position.

FIG. 32 is a front elevation view of the fuel tank lock component in a closed position.

FIG. 33 is a left side elevation view of the fuel tank lock component in a closed position.

FIG. 34 is a rear elevation view of the fuel tank lock component in a closed position.

FIG. 35 is a left front perspective view of the engine compartment component of the helicopter securing component kit of the present design illustrating the subcomponents in an open position.

FIG. 36 is a left front perspective view of the engine compartment component illustrating the subcomponents in a closed position.

FIG. 37 is a top planar view of the engine compartment component in a closed position

FIG. 38 is a bottom planar view of the engine compartment component in a closed position.

FIG. 39 is a front elevation view of the engine compartment component in a closed position.

FIG. 40 is a rear elevation view of the engine compartment component in a closed position.

FIG. 41 is a right side elevation view of the engine compartment component in a closed position.

FIG. 42 is a front perspective view of the port window lock component of the helicopter securing component kit of the present design; and,

FIG. 43 is a front elevation view of the port window lock component.

The drawings show 8 securing components which comprise the helicopter securing component kit. FIGS. 1 to 5 show a crew door lock component, FIGS. 6 to 9 show a cargo door lock component, FIGS. 10 to 15 show a cargo door window lock component, FIGS. 16 to 21 show a pop-up handle lock component, FIGS. 22 to 28 show an ebay lock component, FIGS. 29 to 34 show a fuel tank lock component, FIGS. 35 to 41 show an engine compartment lock component and FIG. 42 to 43 show a port window lock component.

FIG. 9 illustrates an environment element with which the cargo door lock component may cooperate in broken lines, the broken lines not forming any part of the claimed design.

The broken line showing is included for the purpose of illustrating and forms no part of the claimed design.

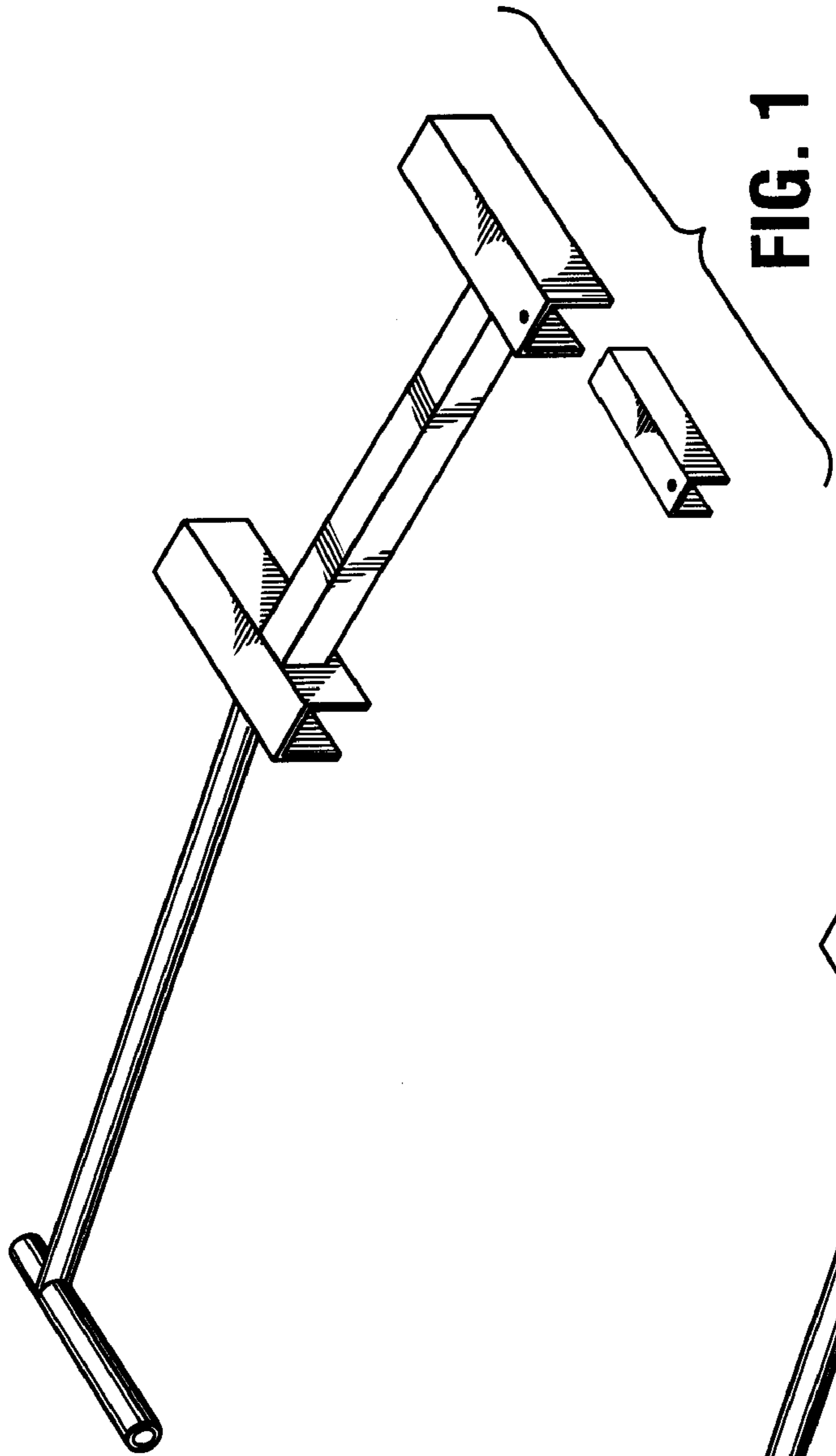

FIG. 1

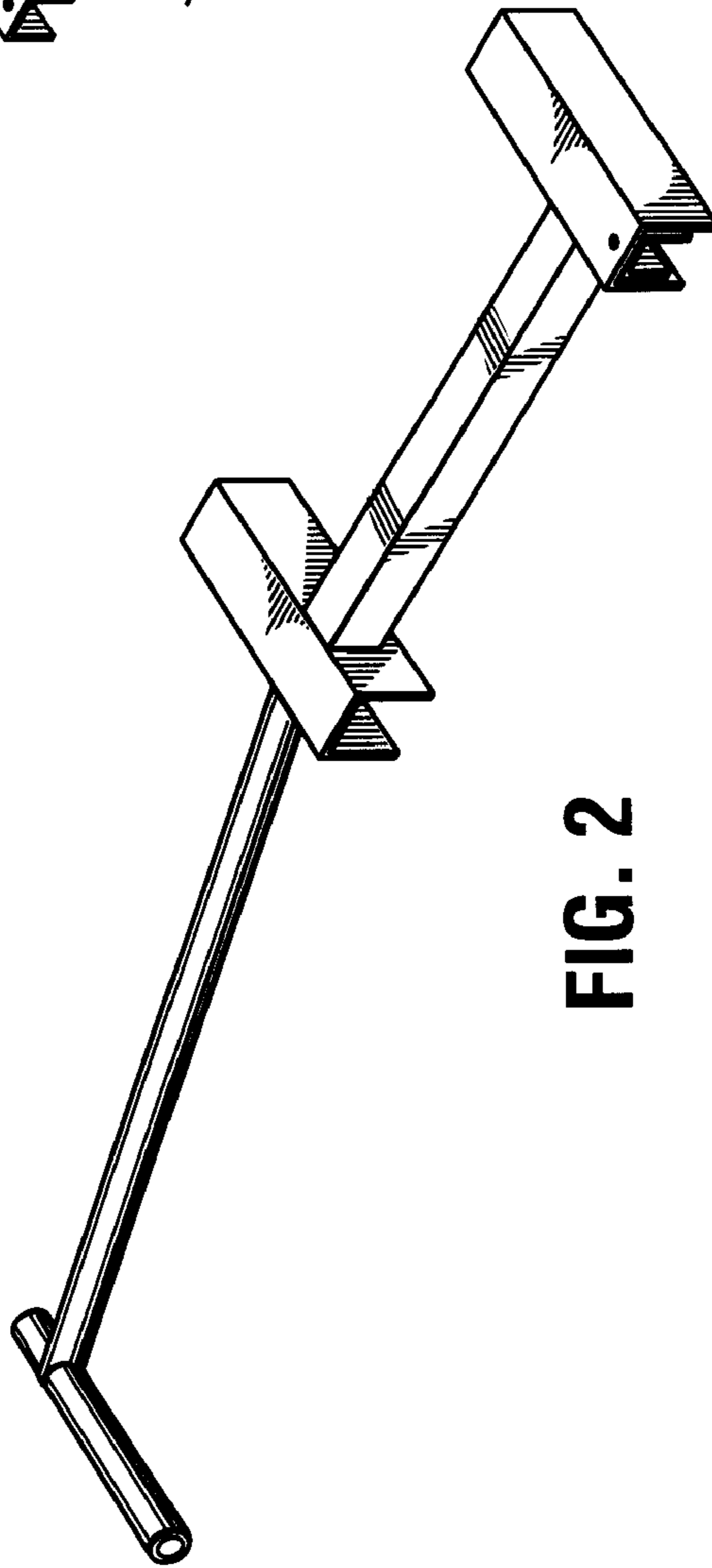

FIG. 2

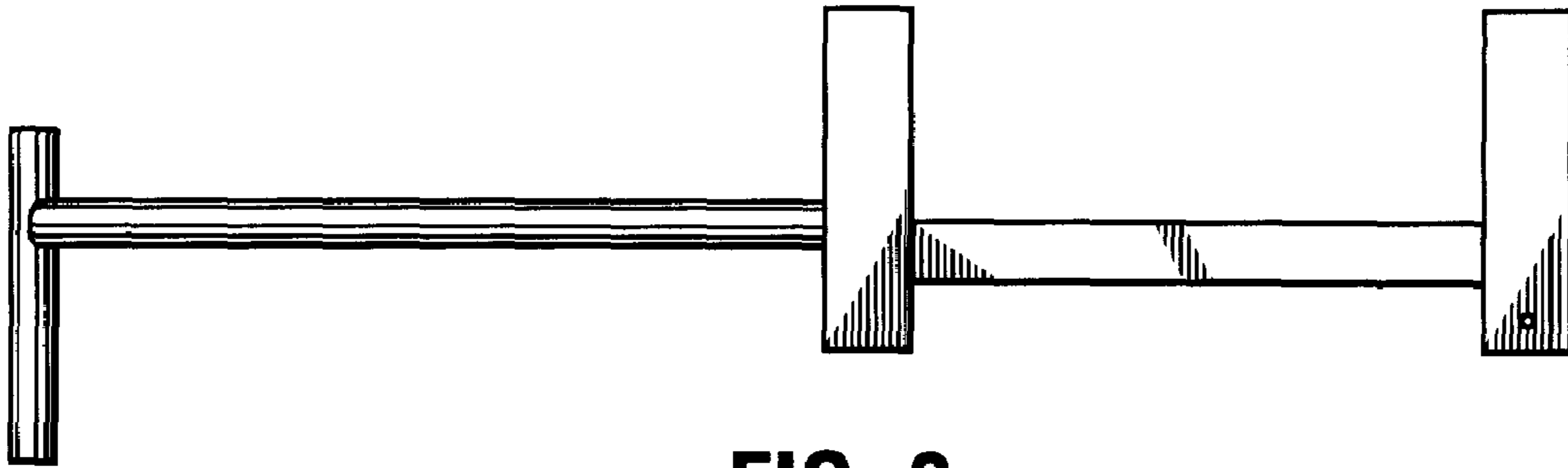

FIG. 3



FIG. 4

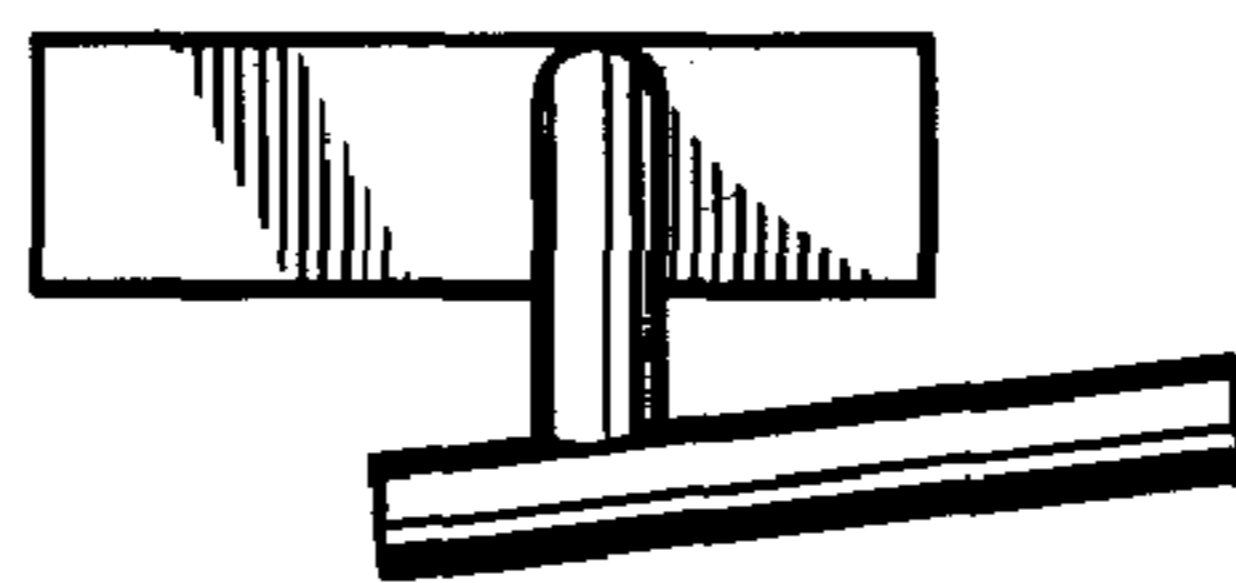

FIG. 5

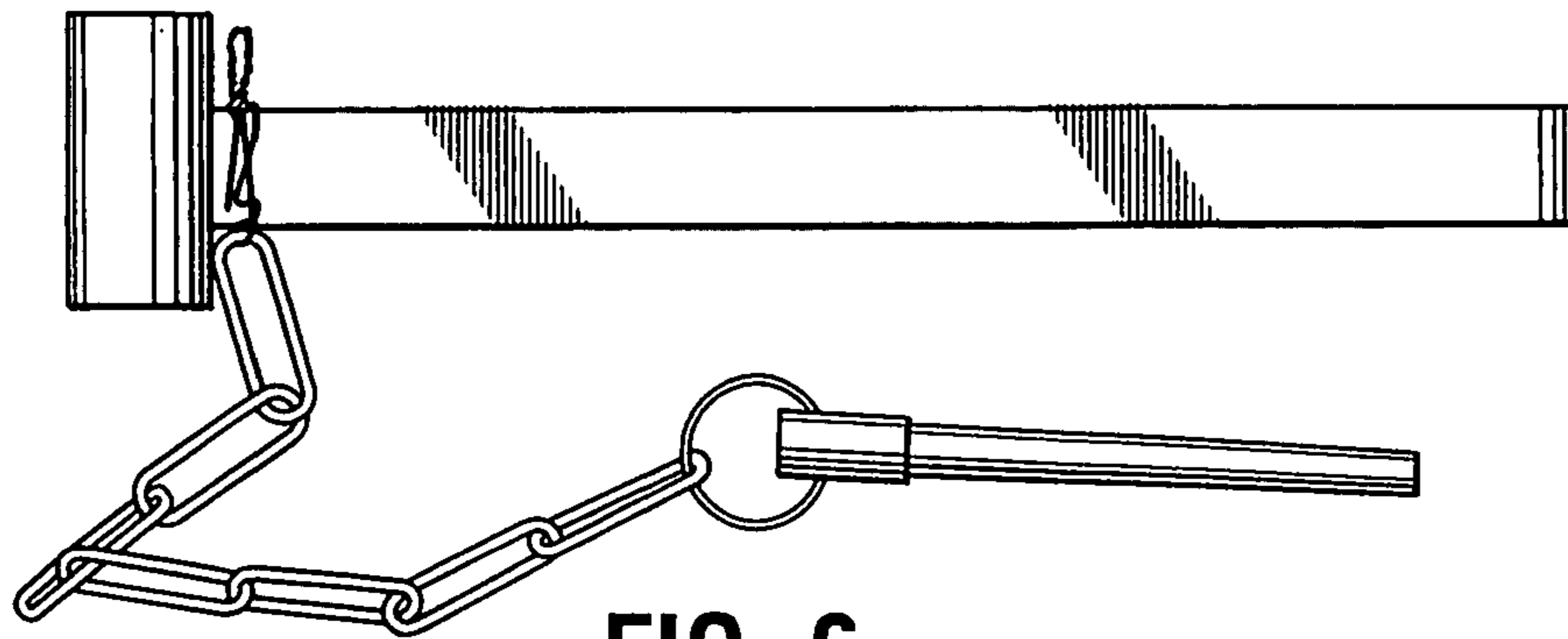

FIG. 6

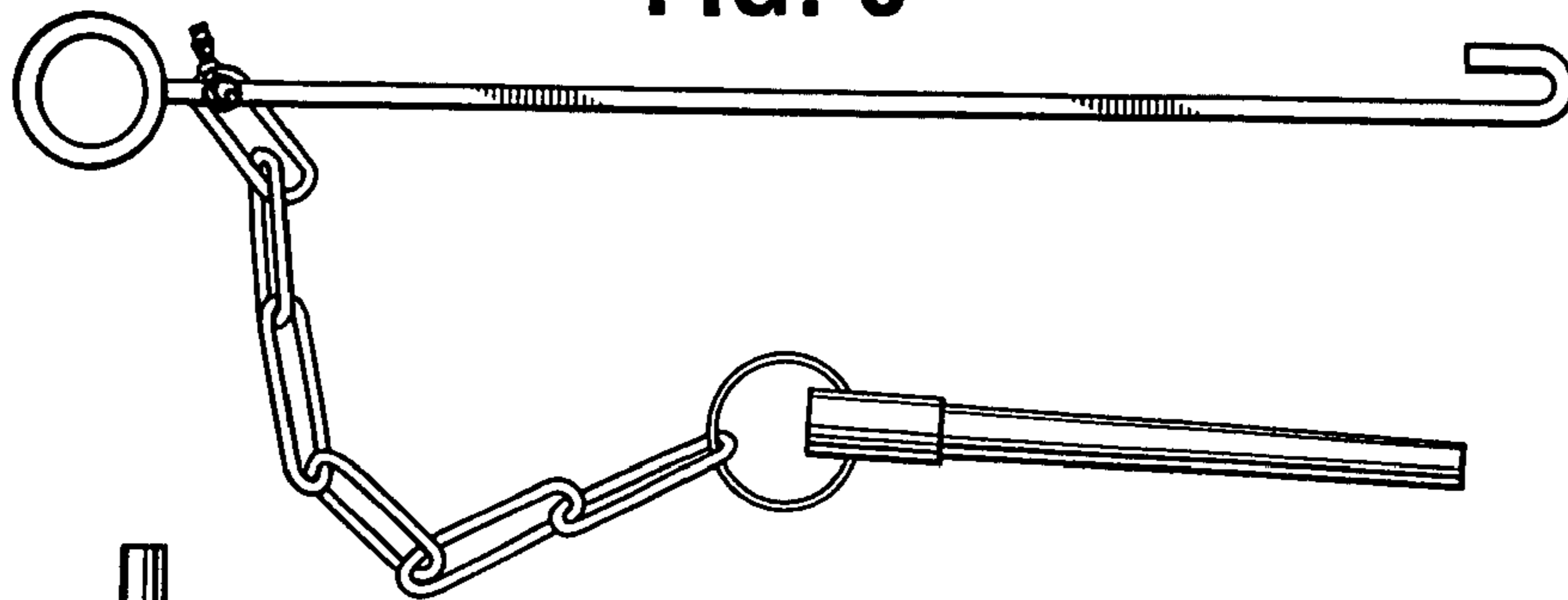

FIG. 7

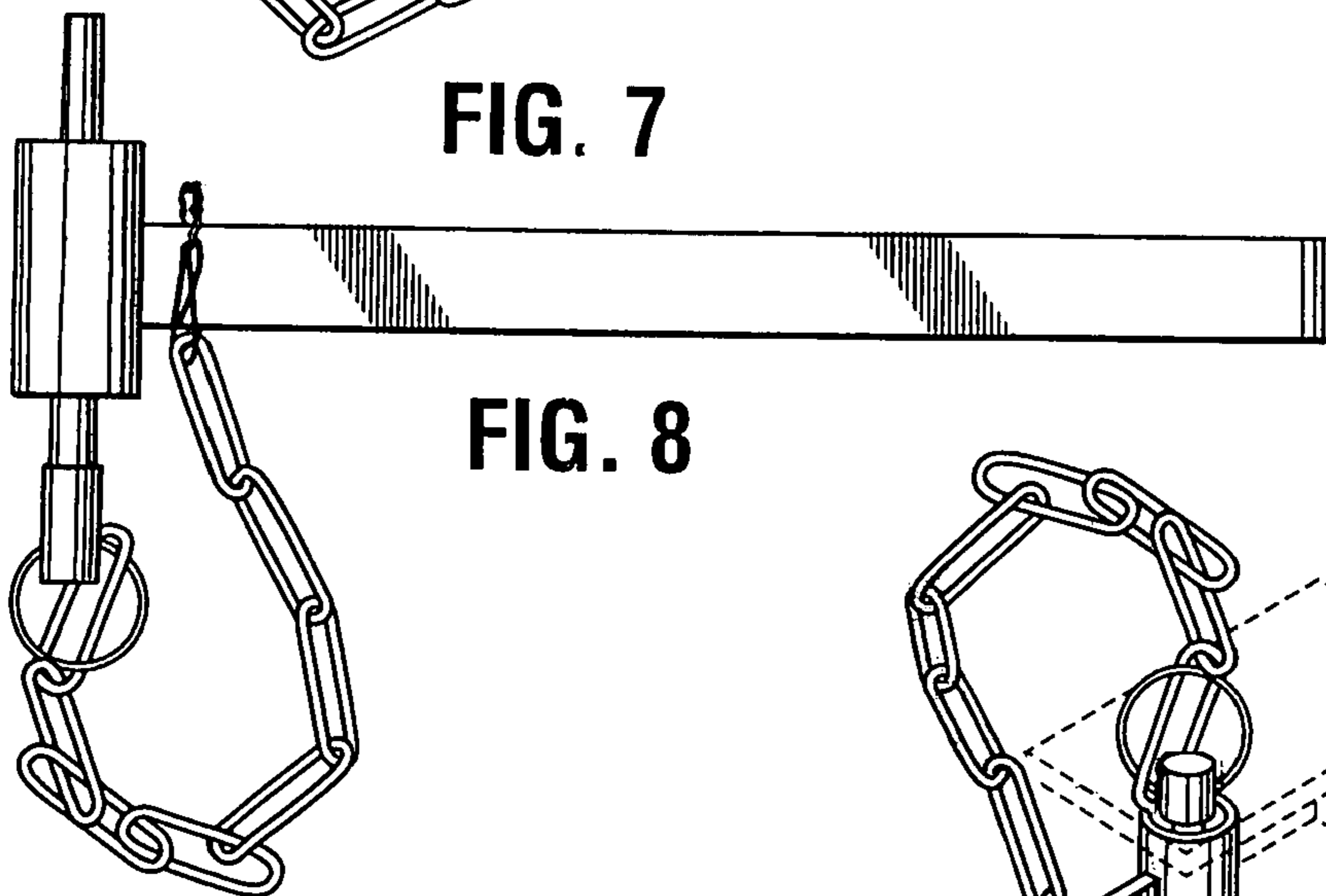

FIG. 8

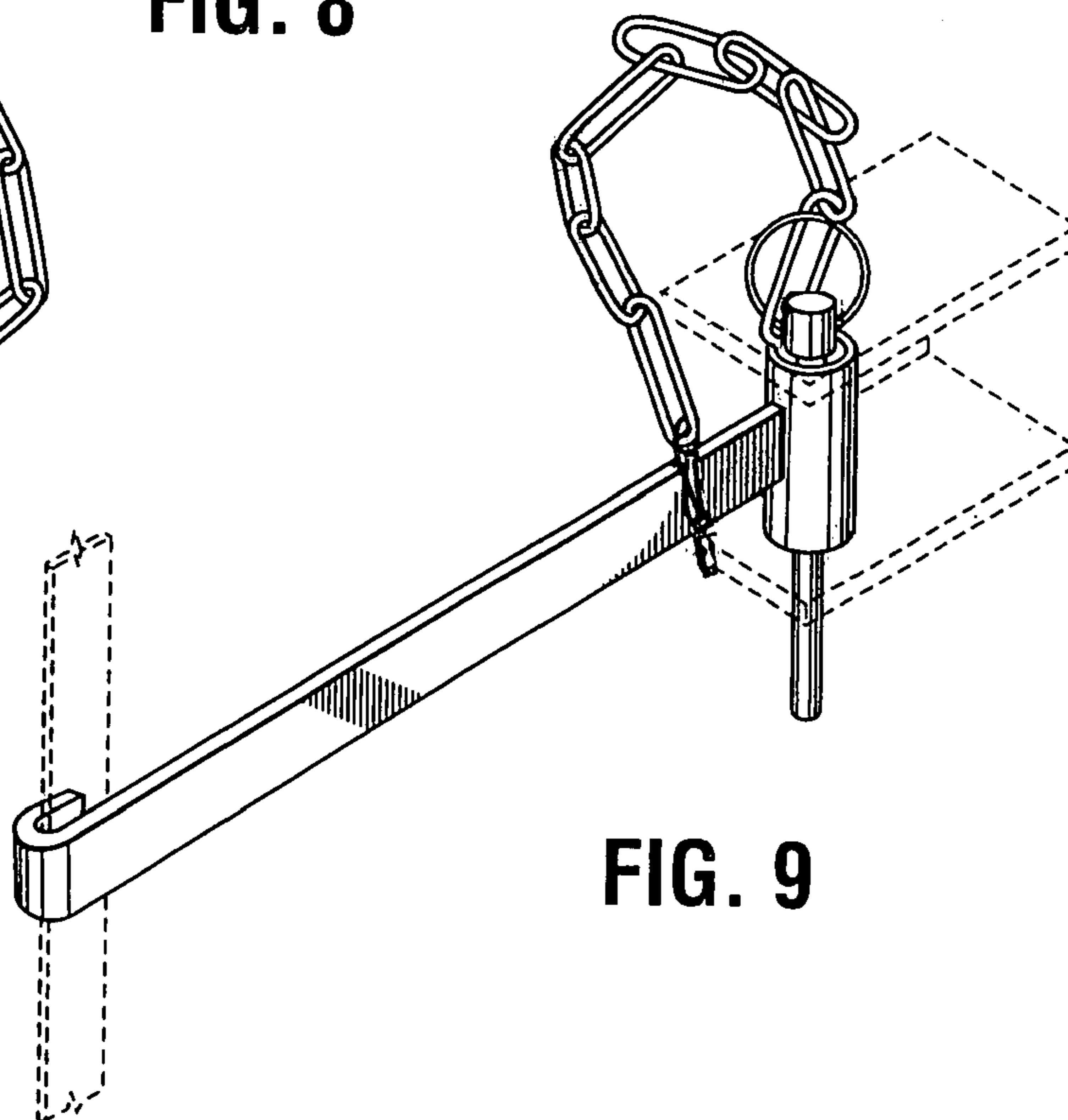

FIG. 9

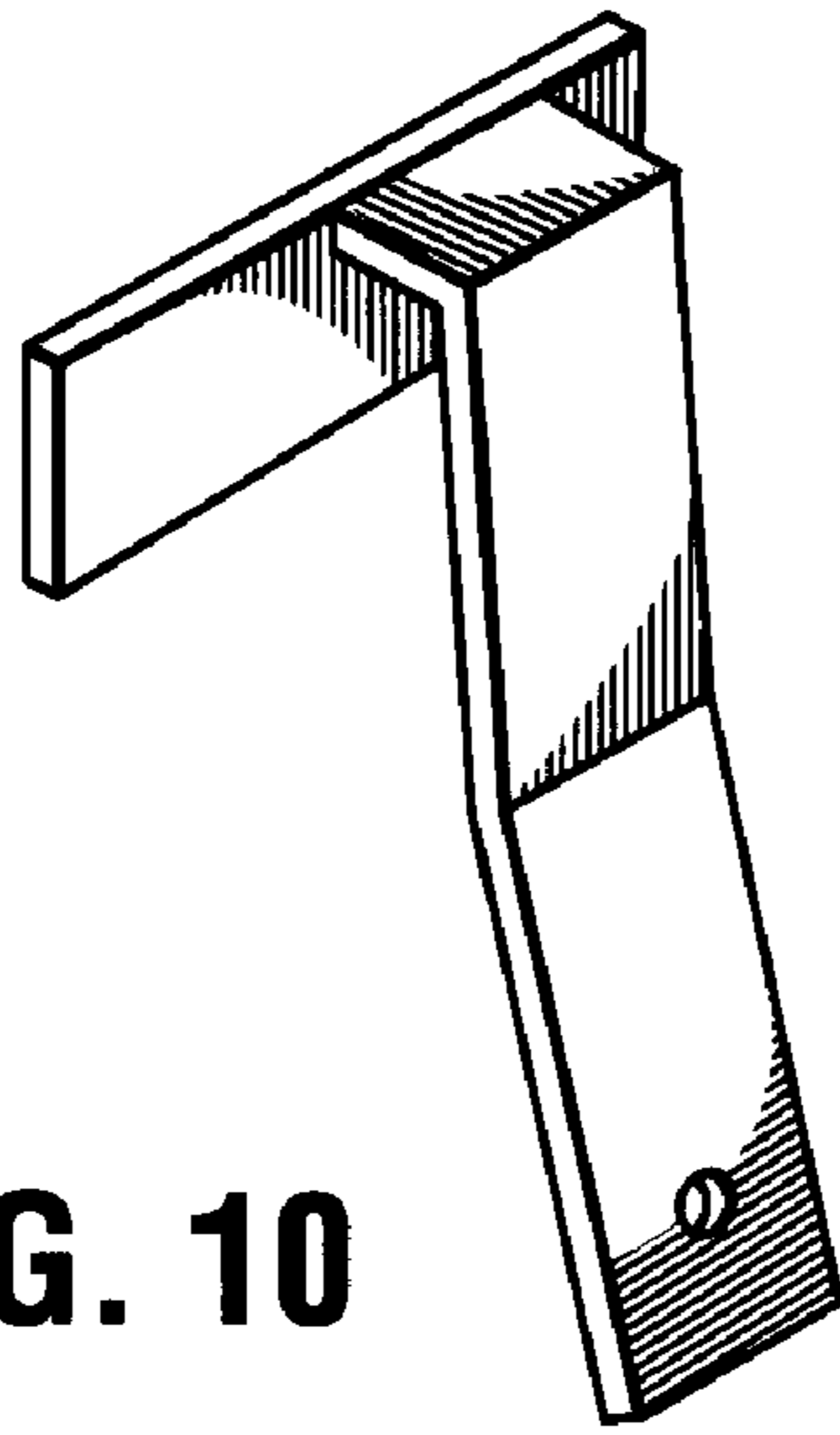

FIG. 10

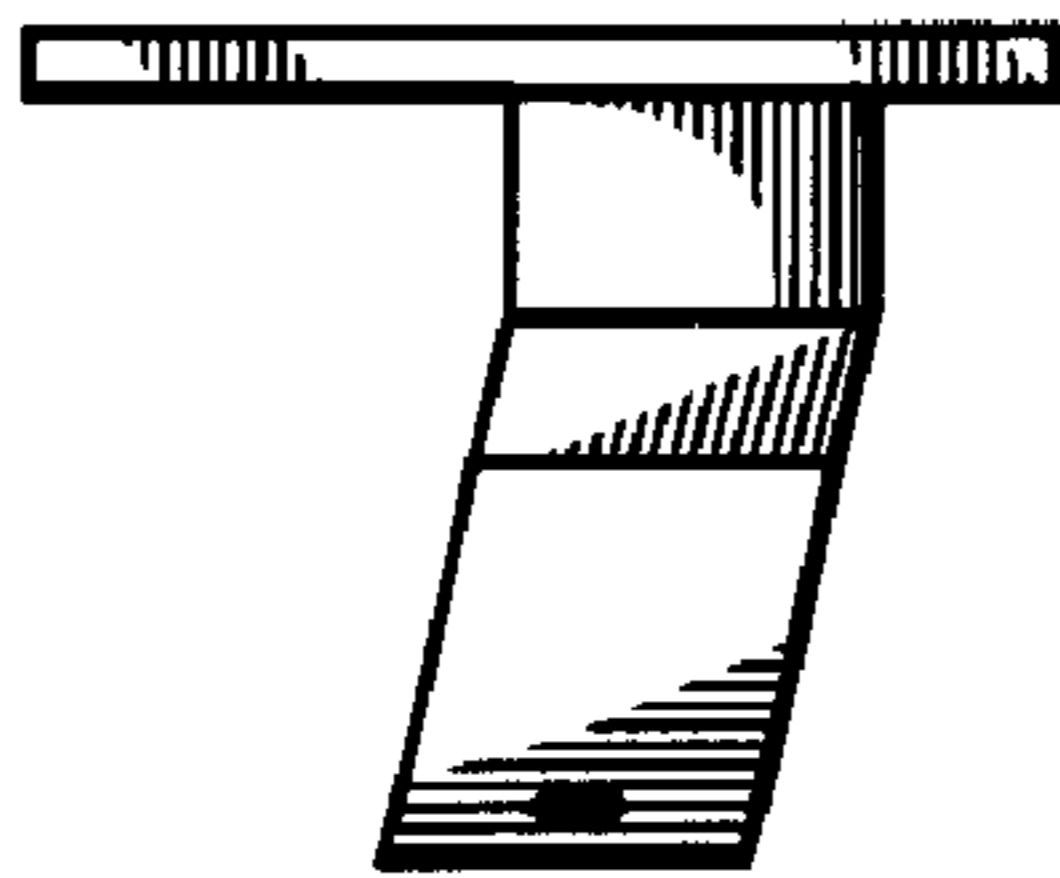

FIG. 11

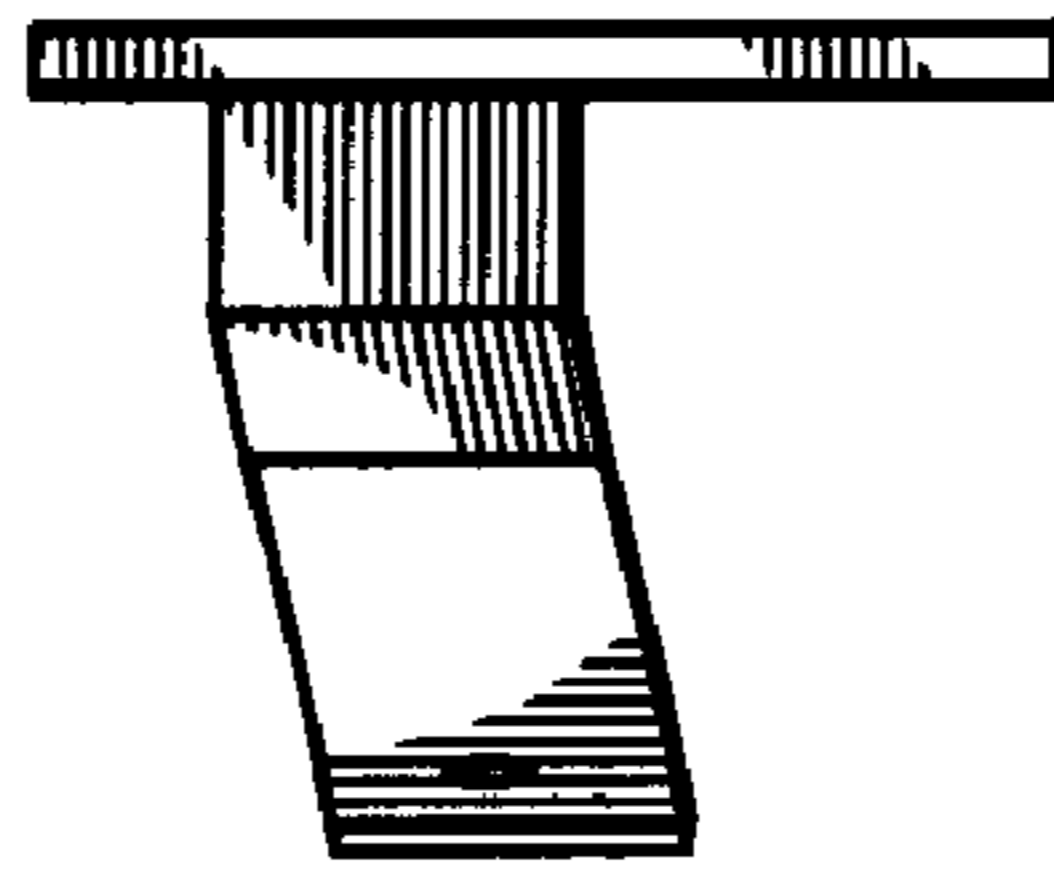

FIG. 12



FIG. 13

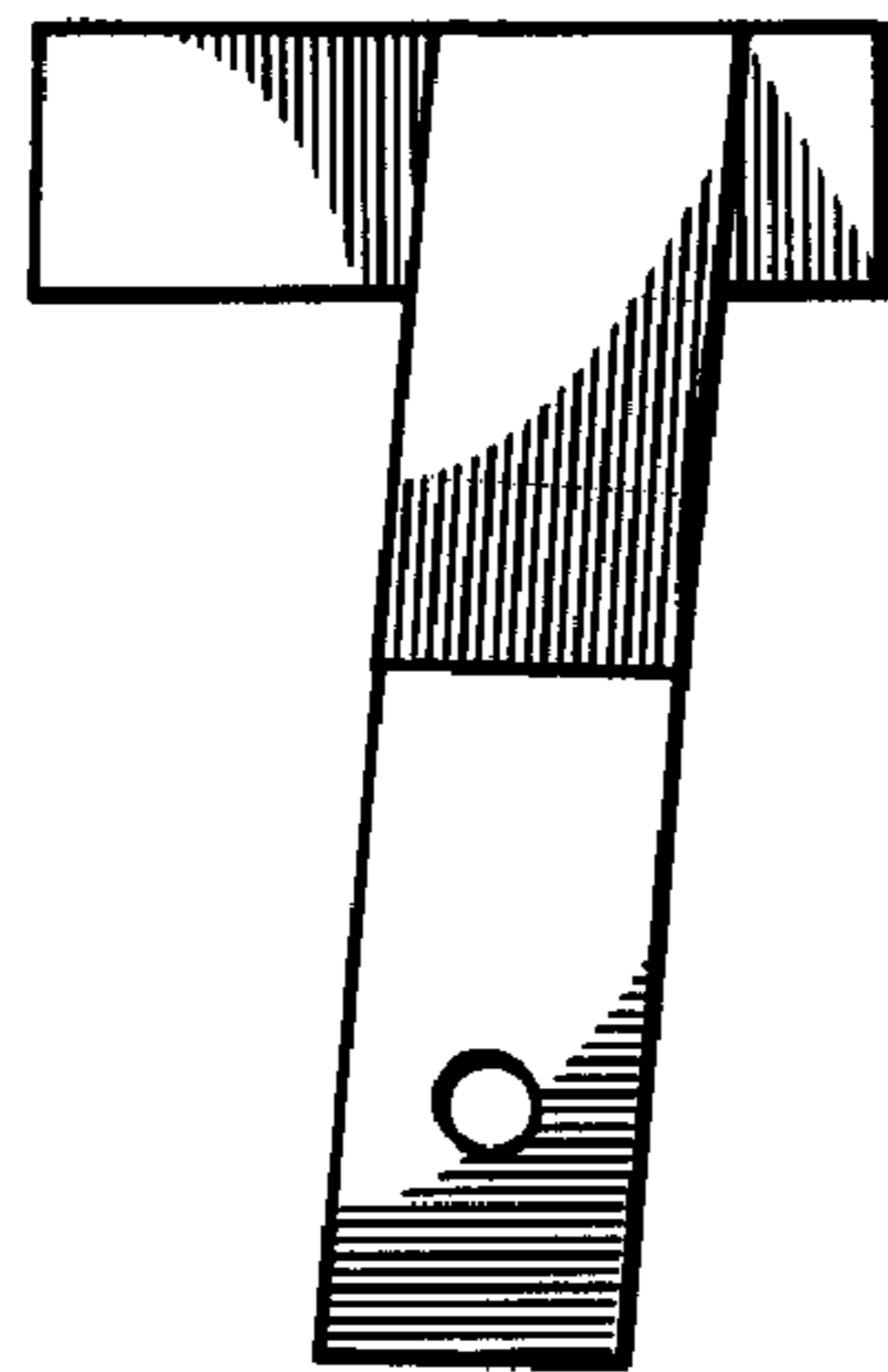

FIG. 14

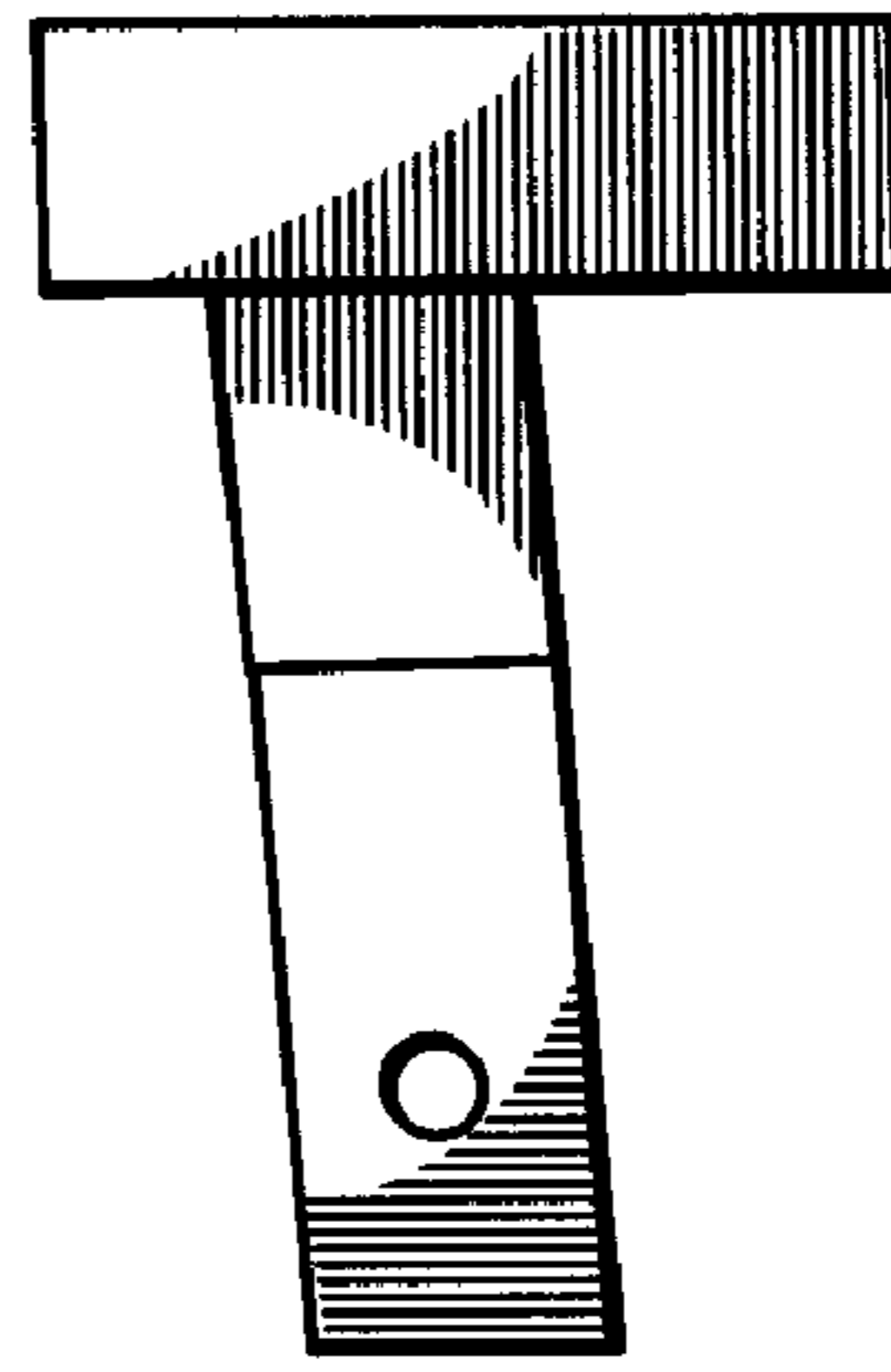

FIG. 15

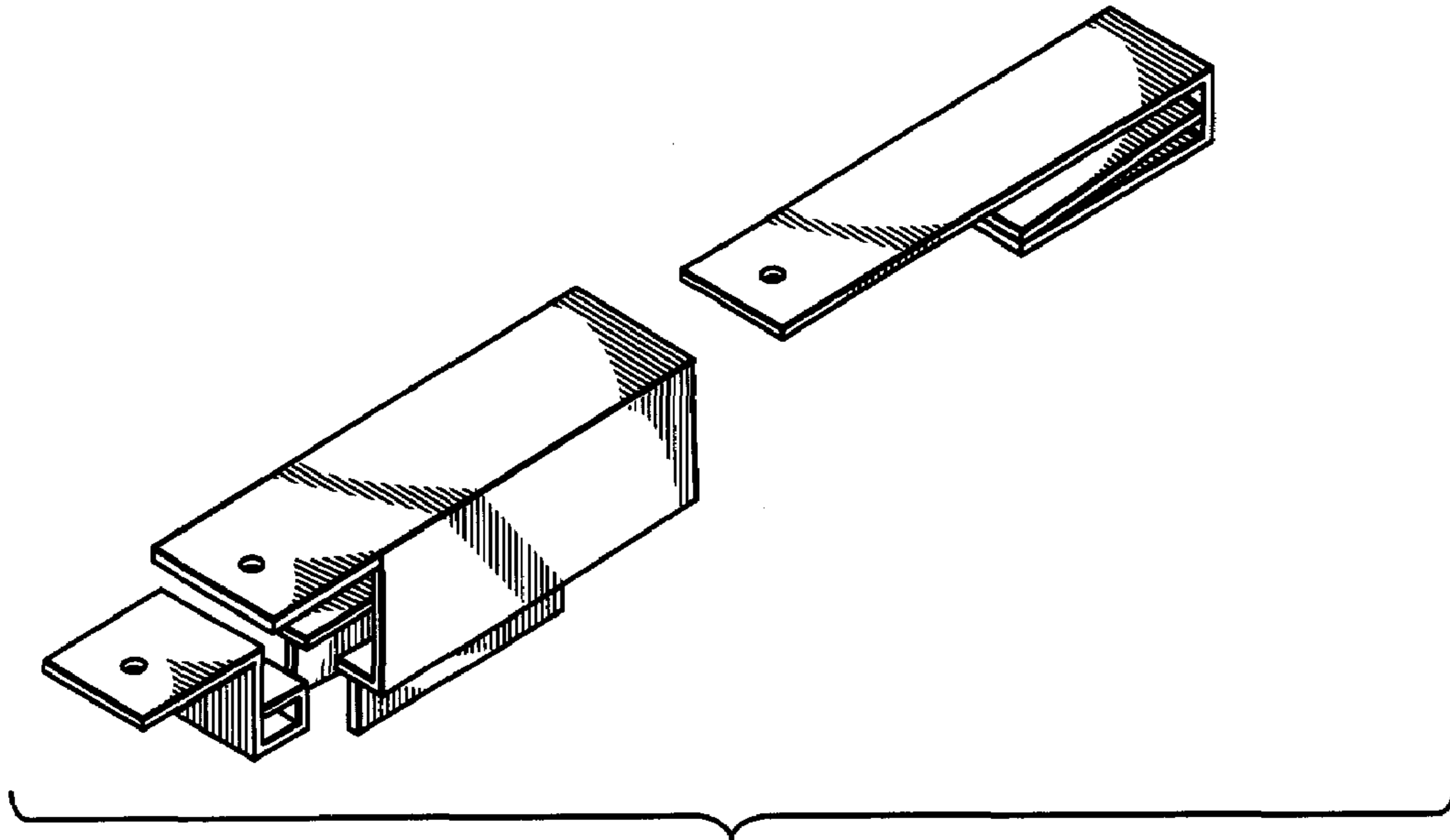

FIG. 16

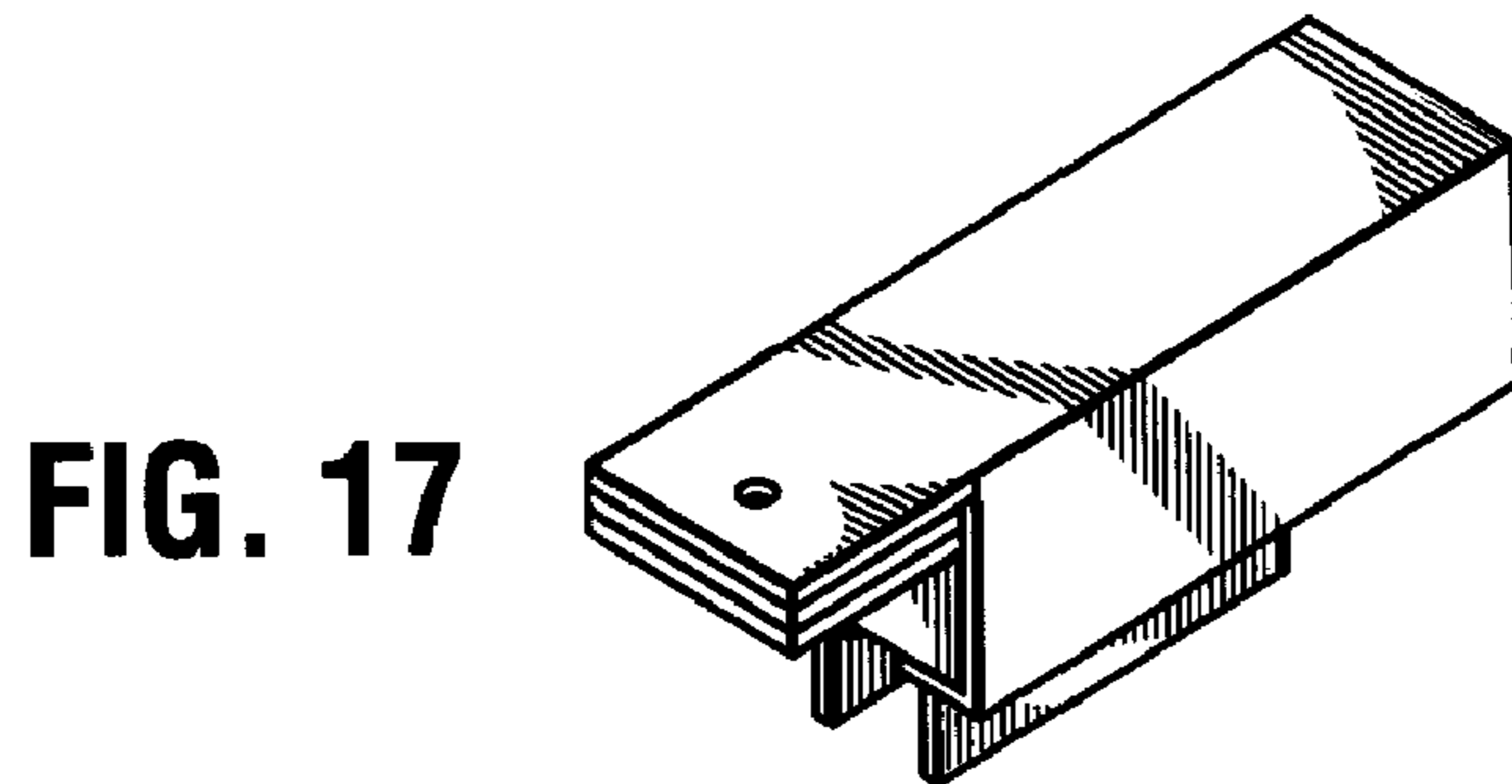

FIG. 17

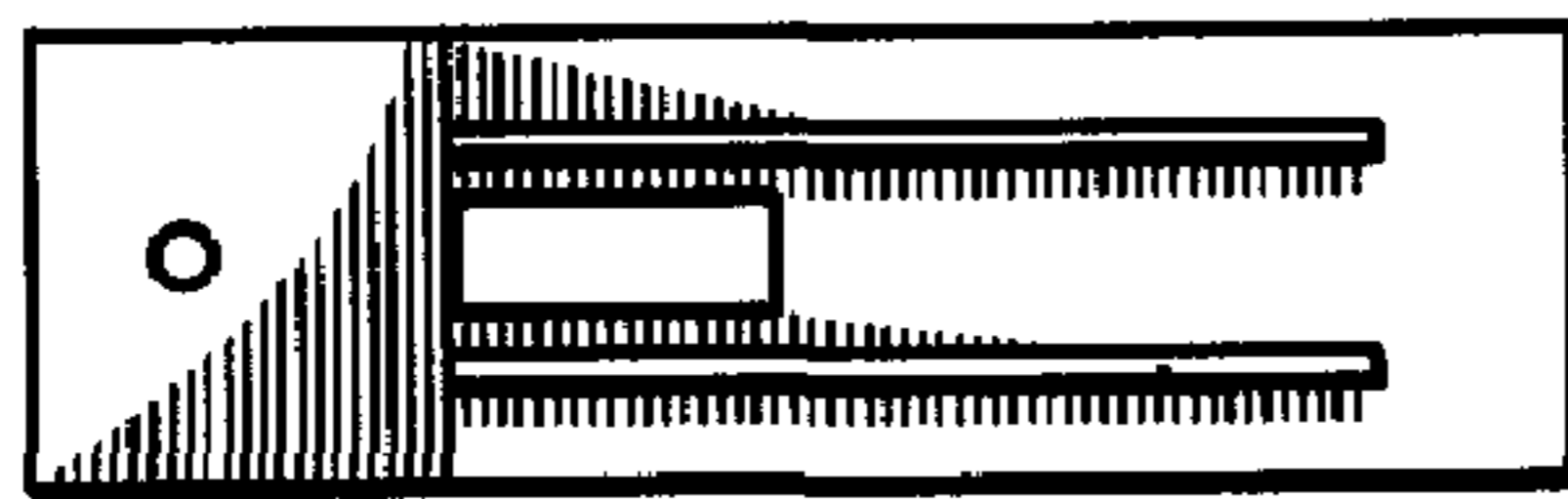

FIG. 18

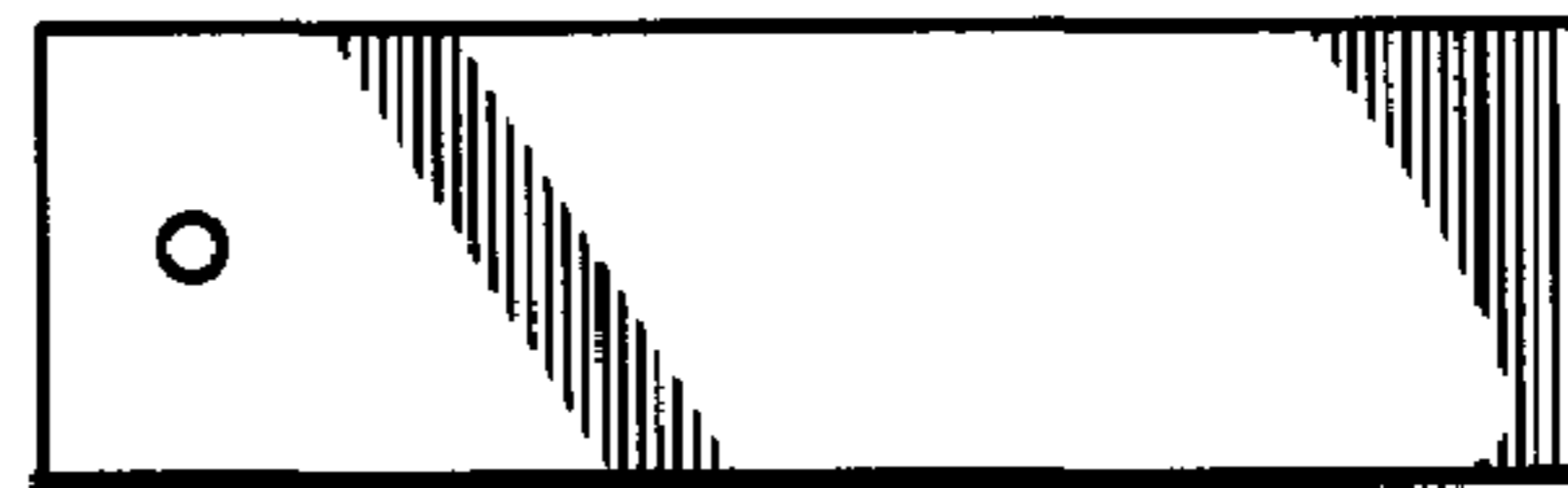

FIG. 19

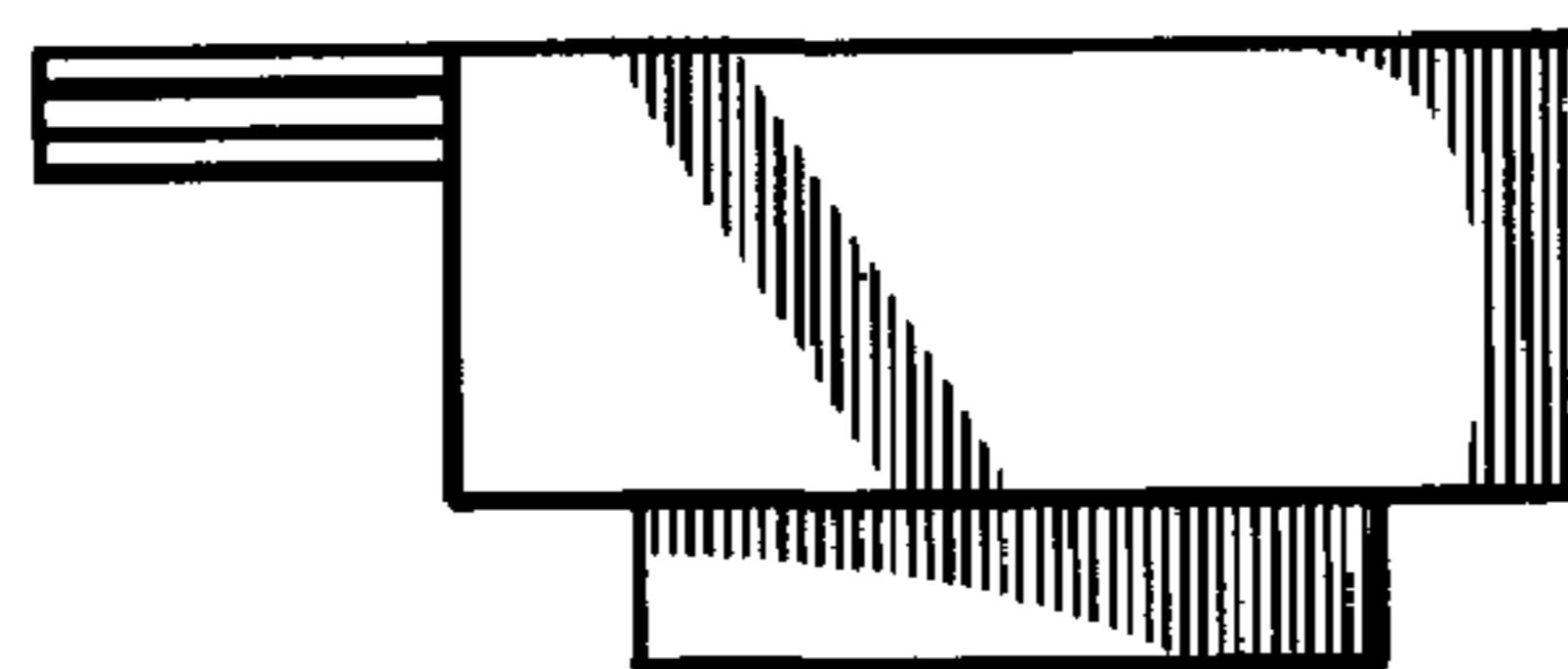

FIG. 20

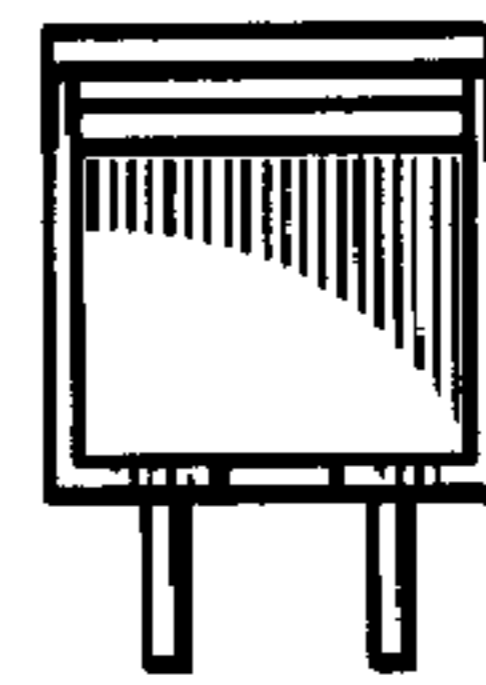
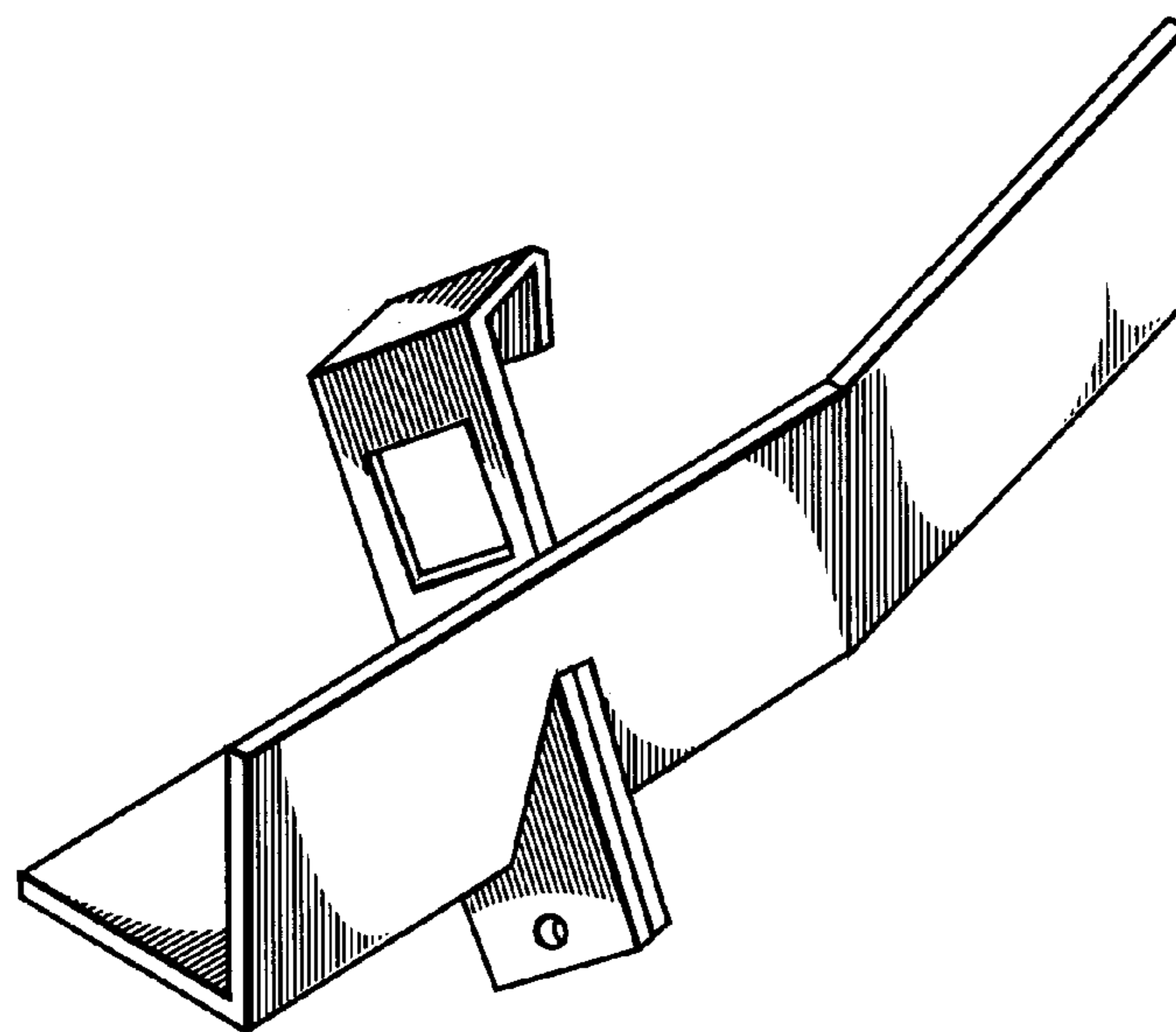
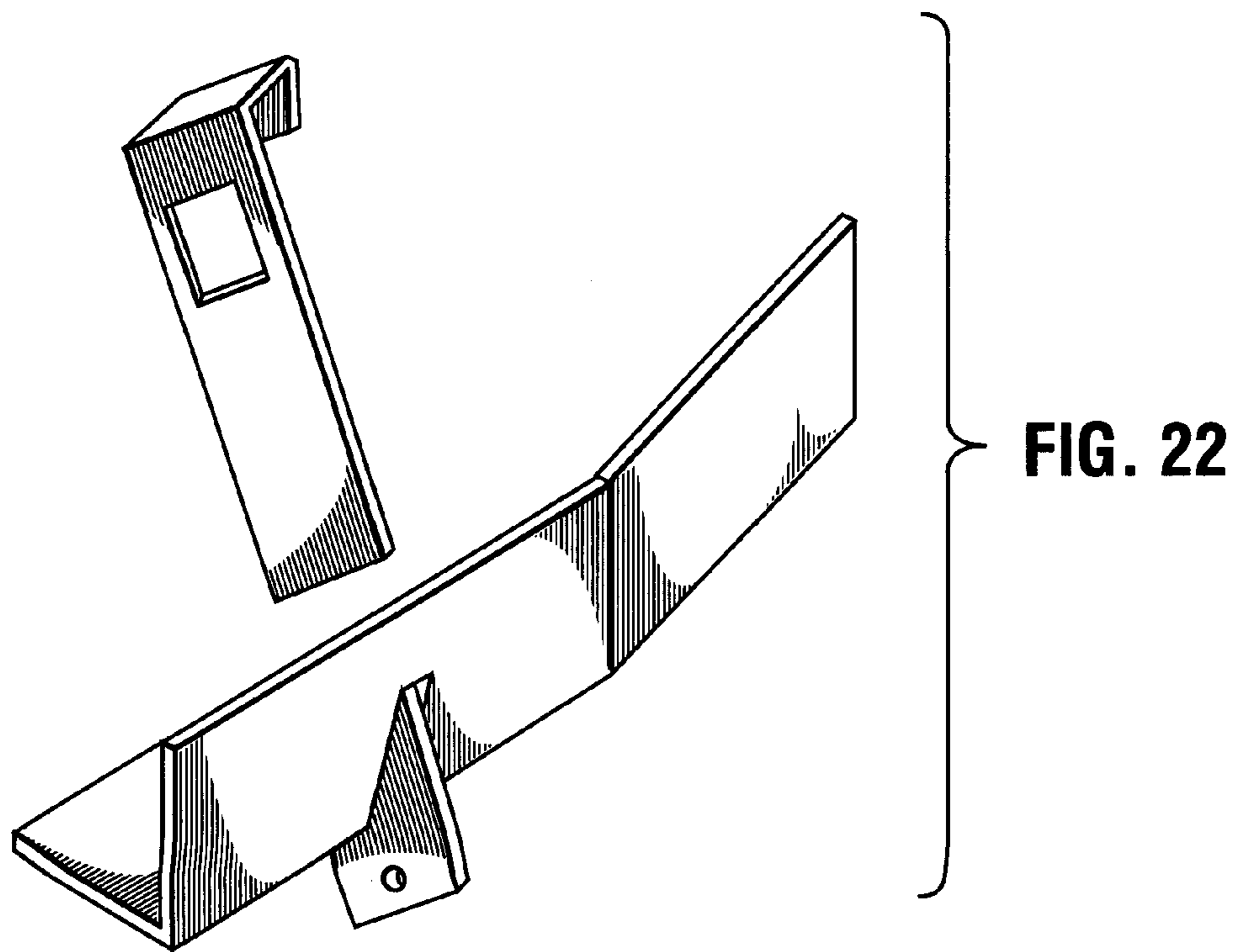

FIG. 21



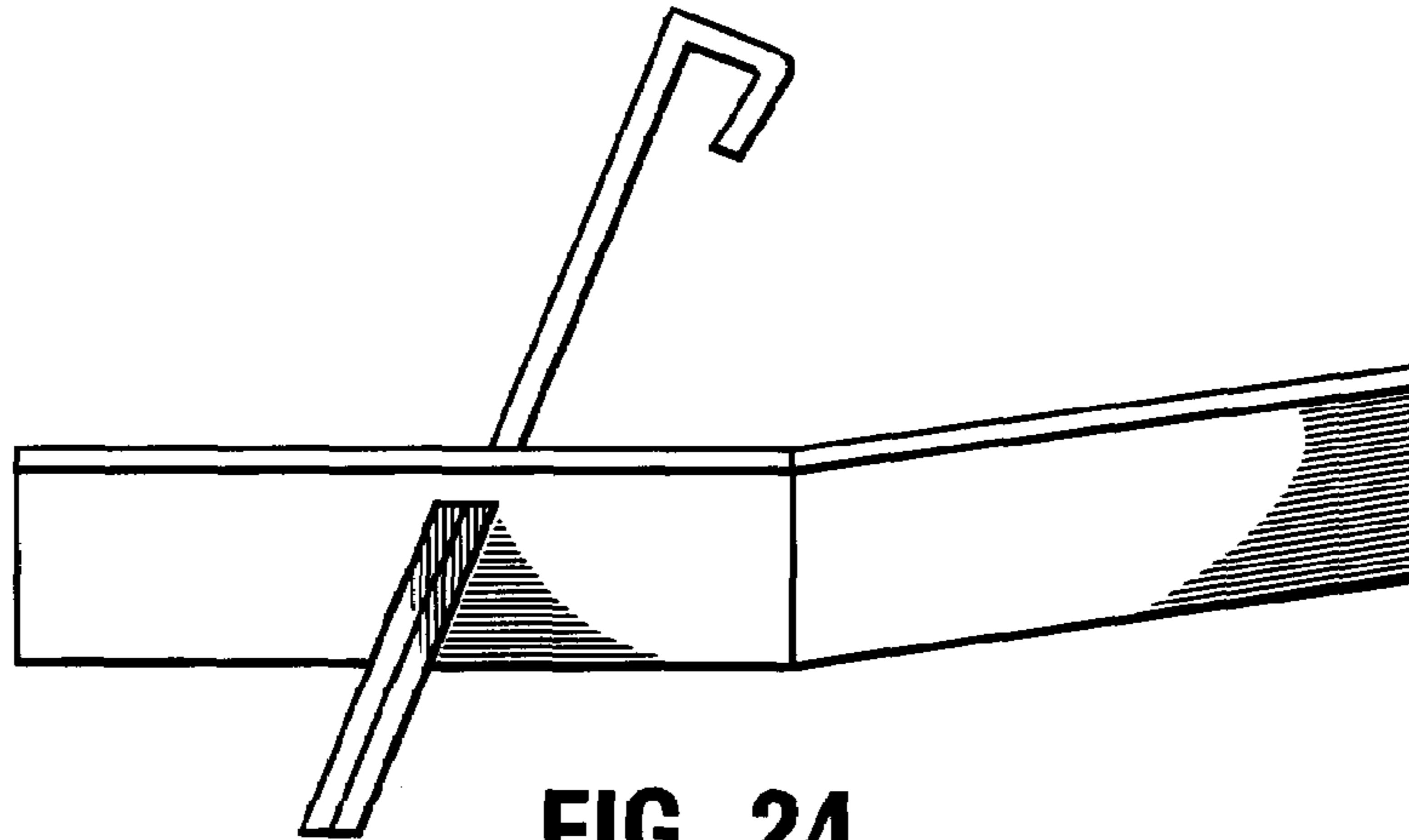

FIG. 24

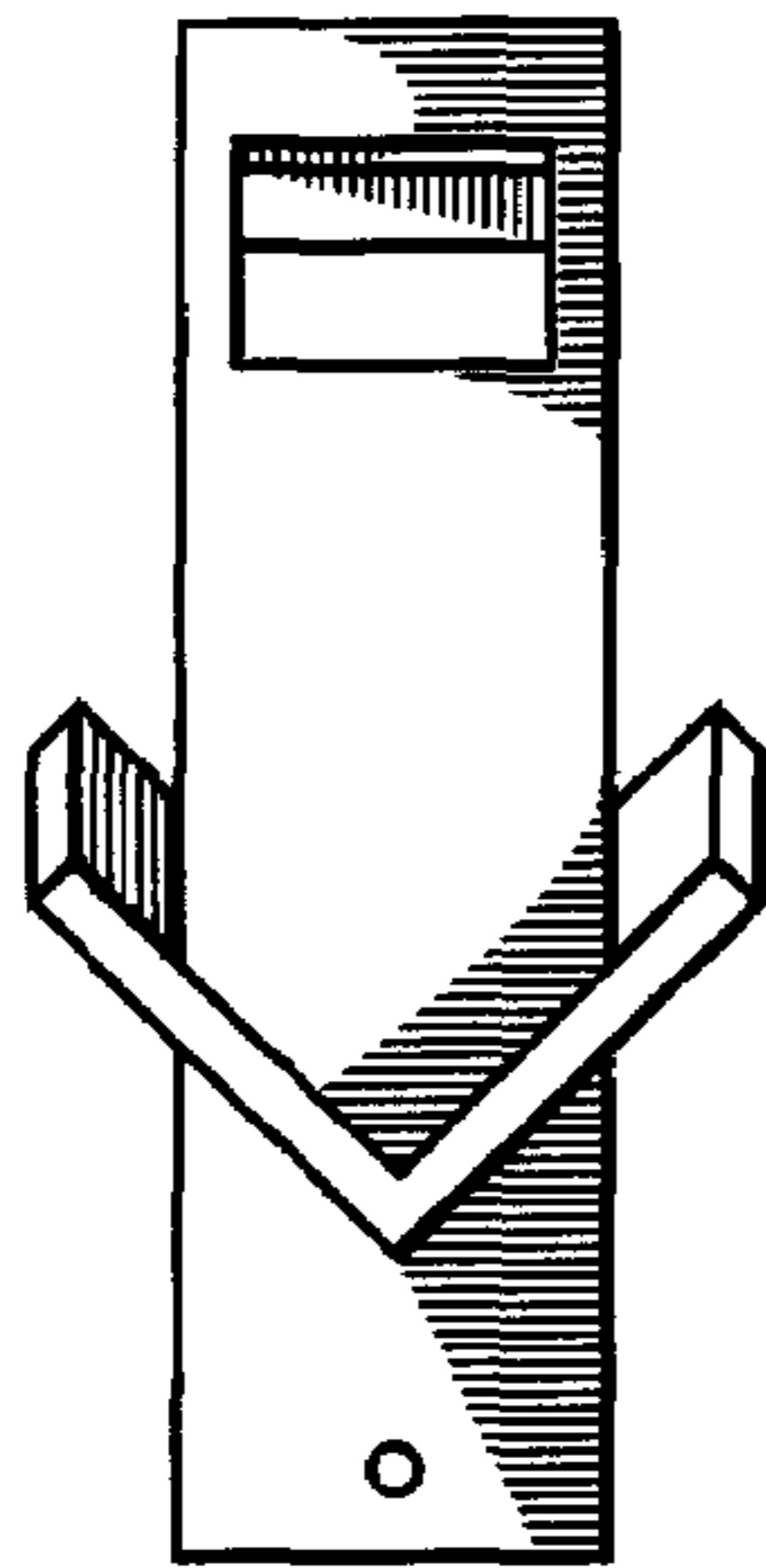

FIG. 25

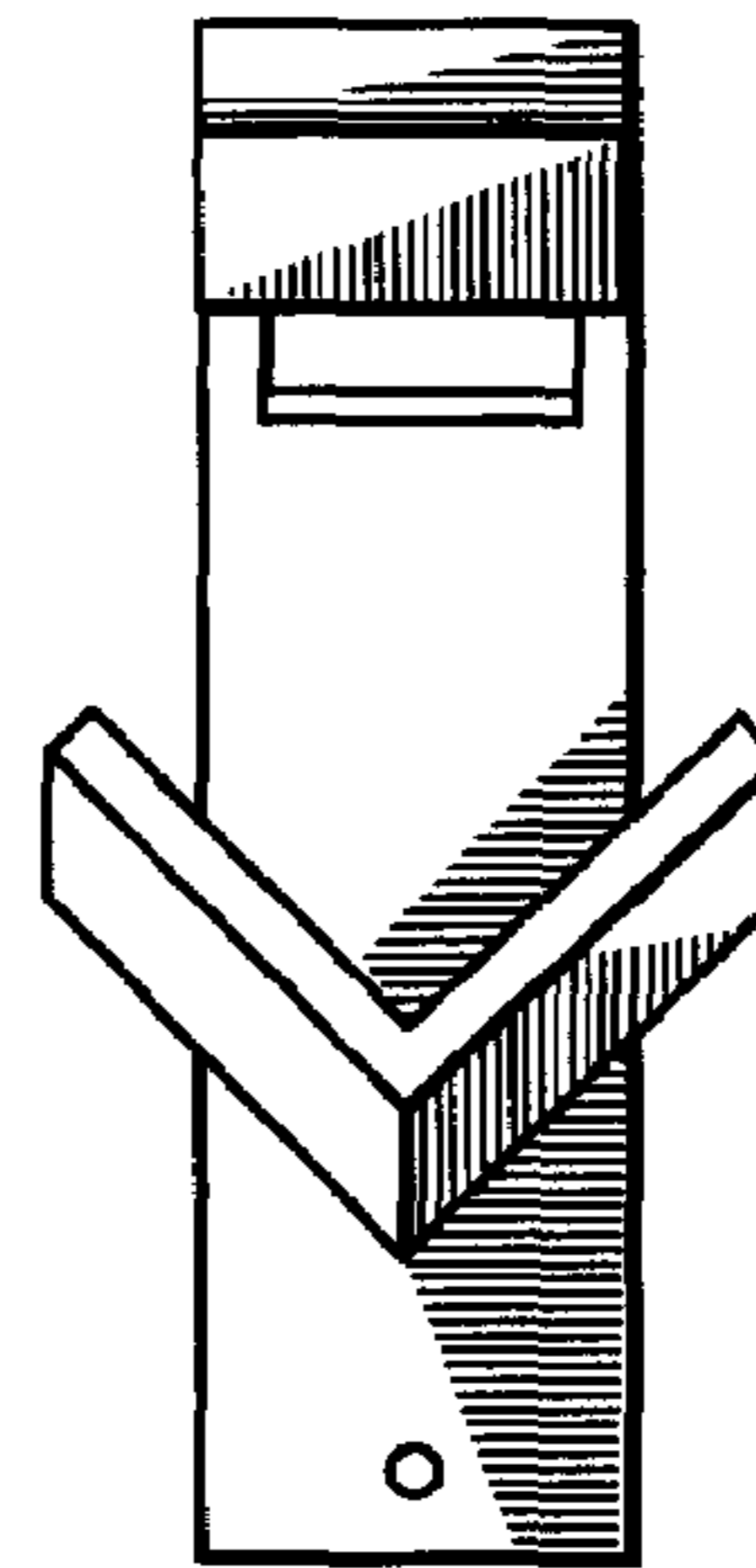

FIG. 26

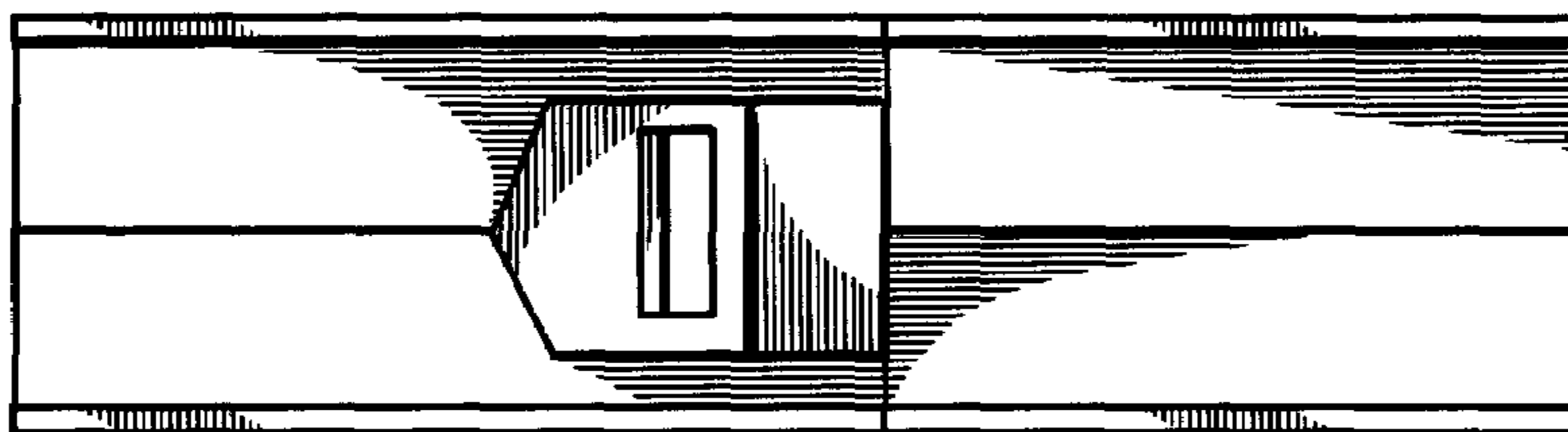

FIG. 27

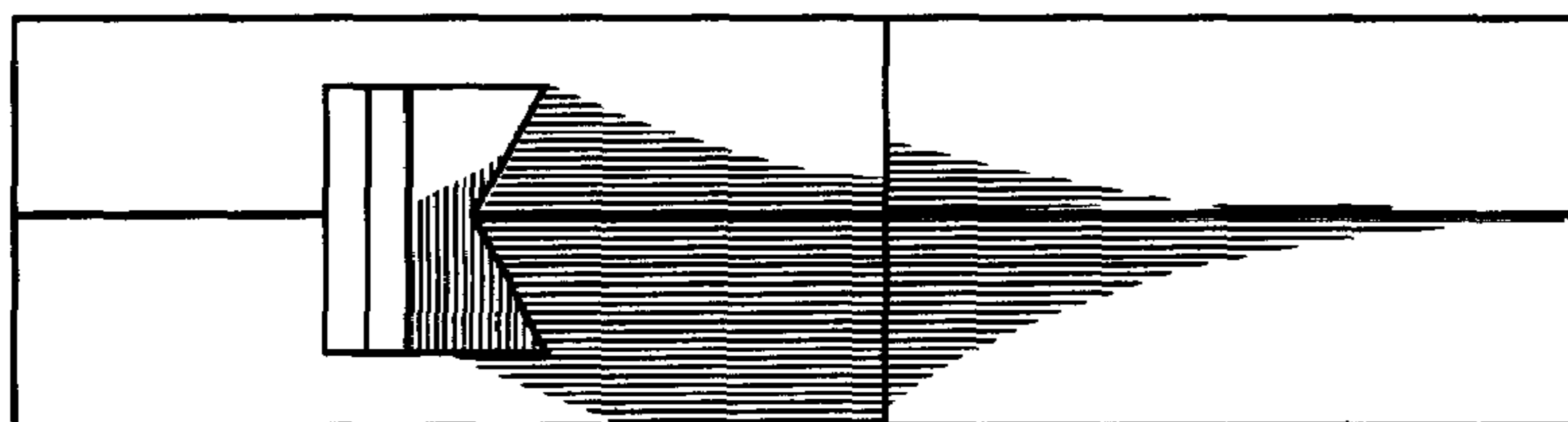

FIG. 28

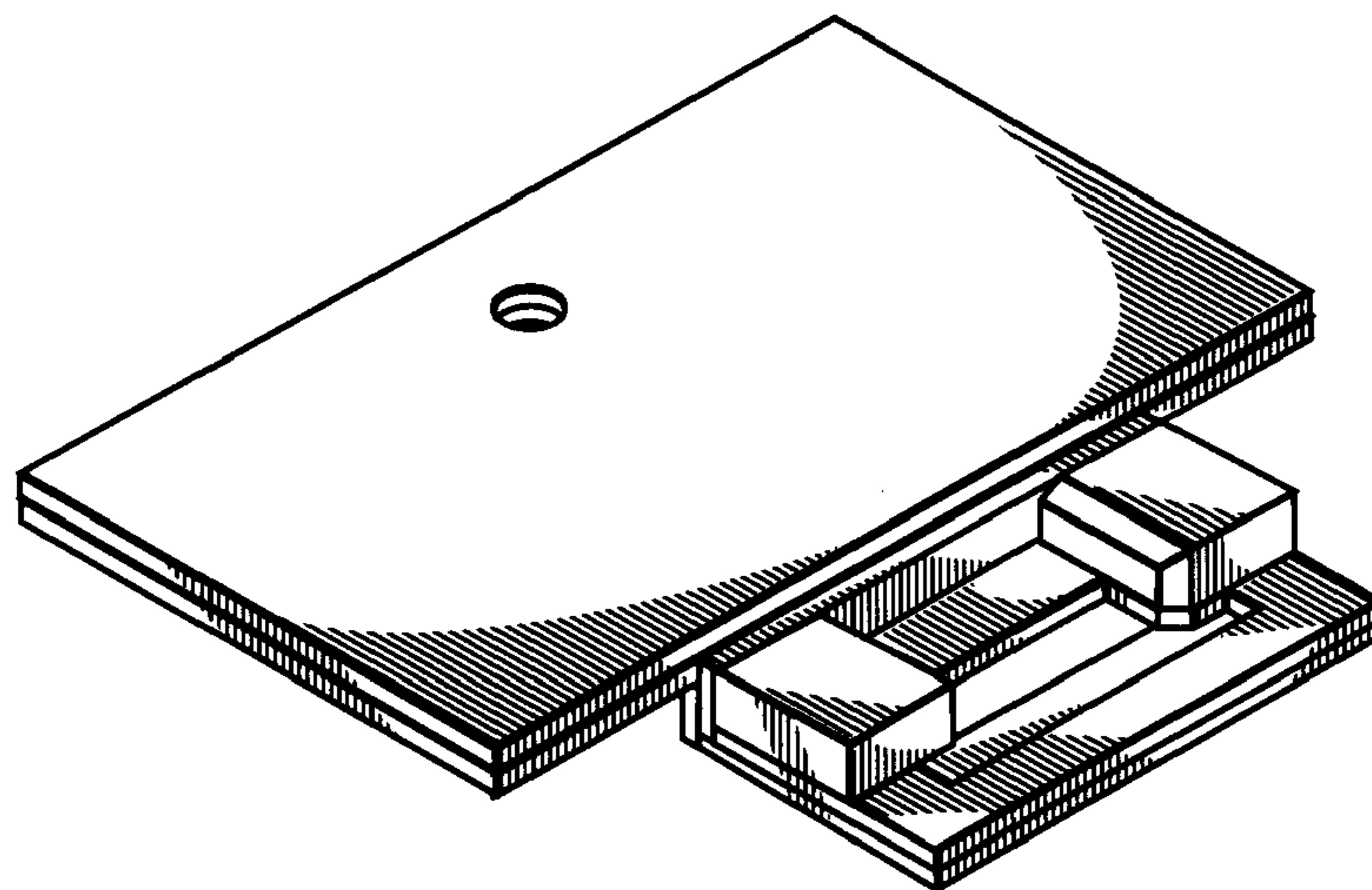
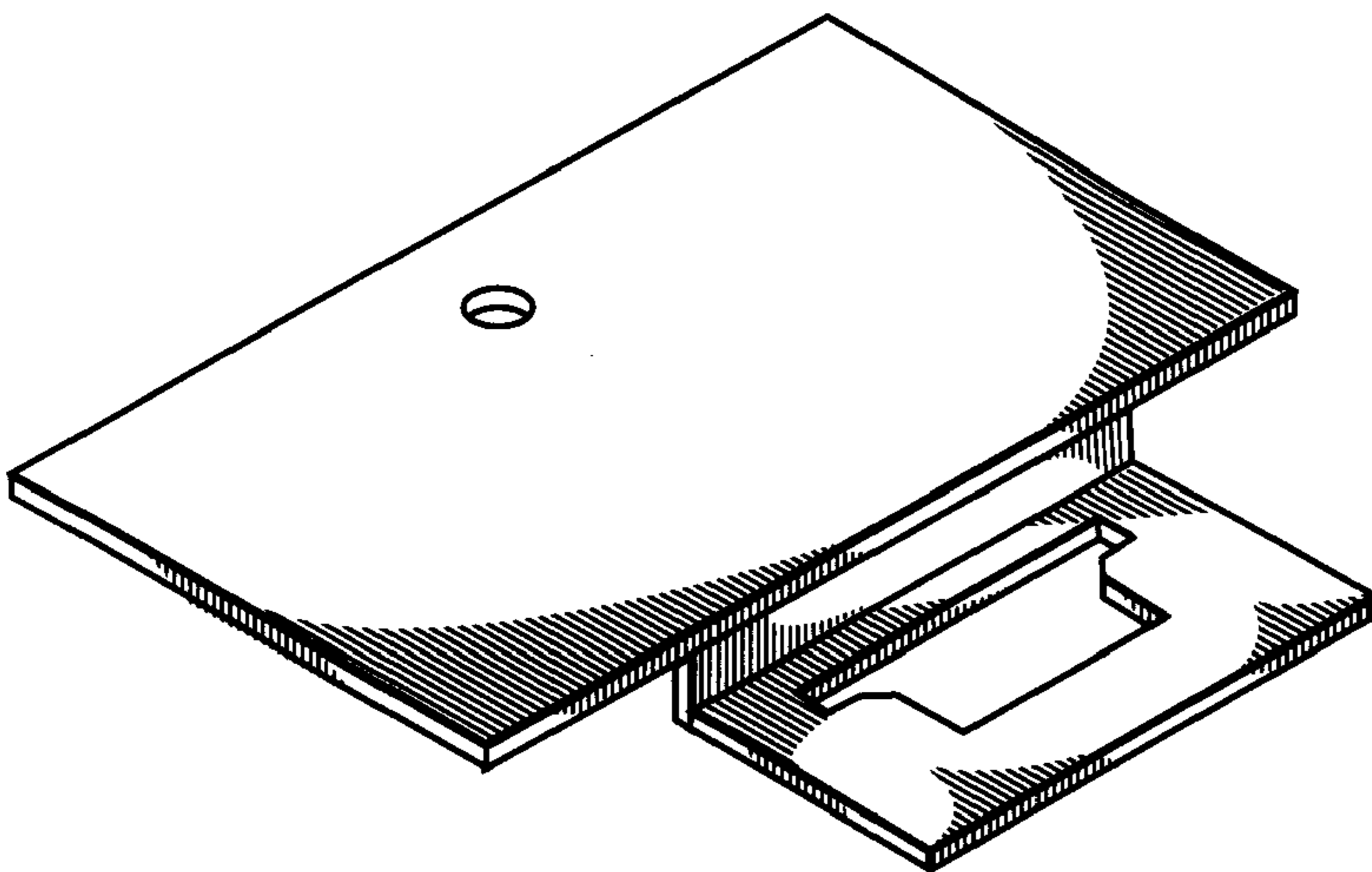
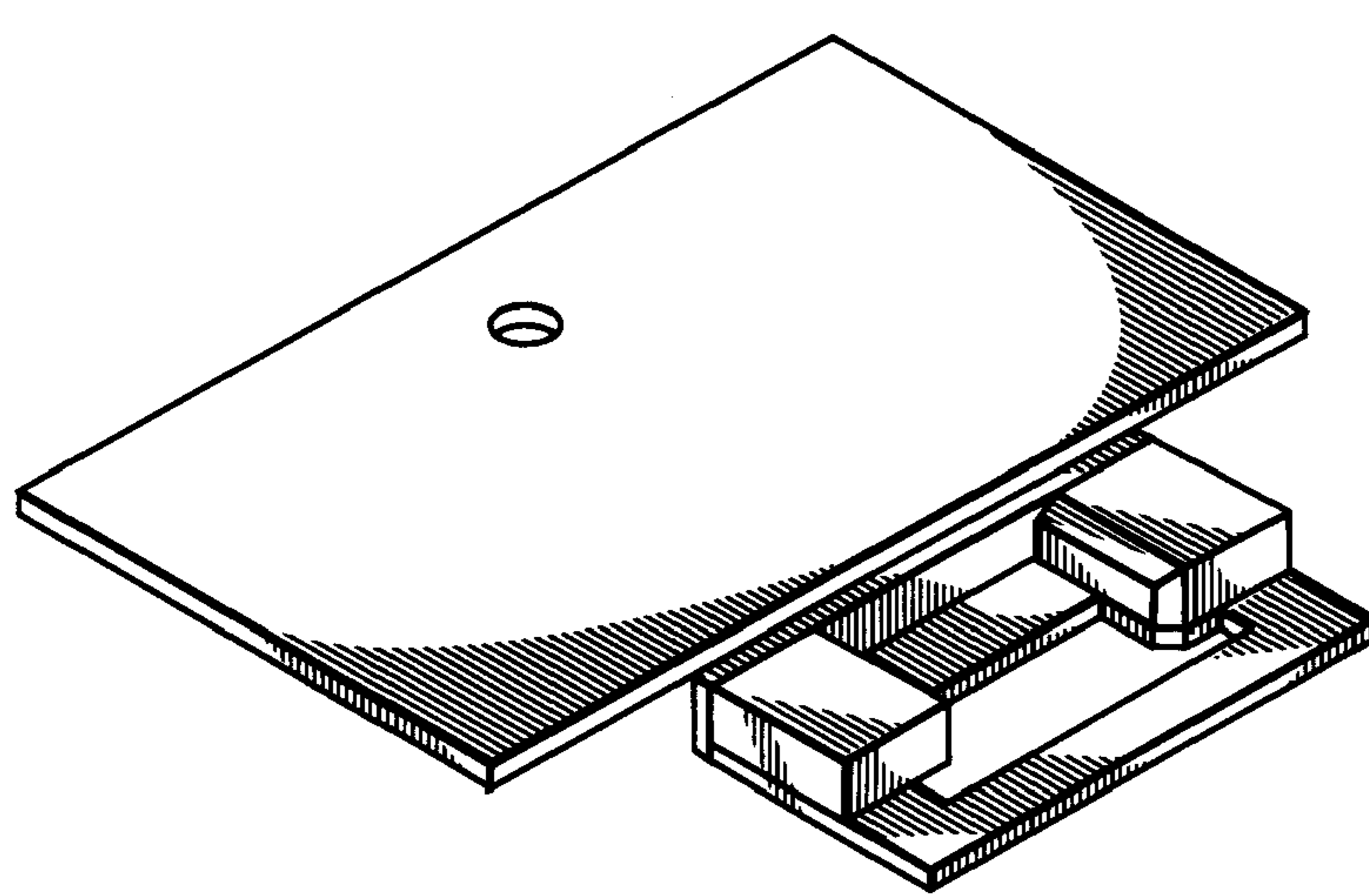

FIG. 29

FIG. 30

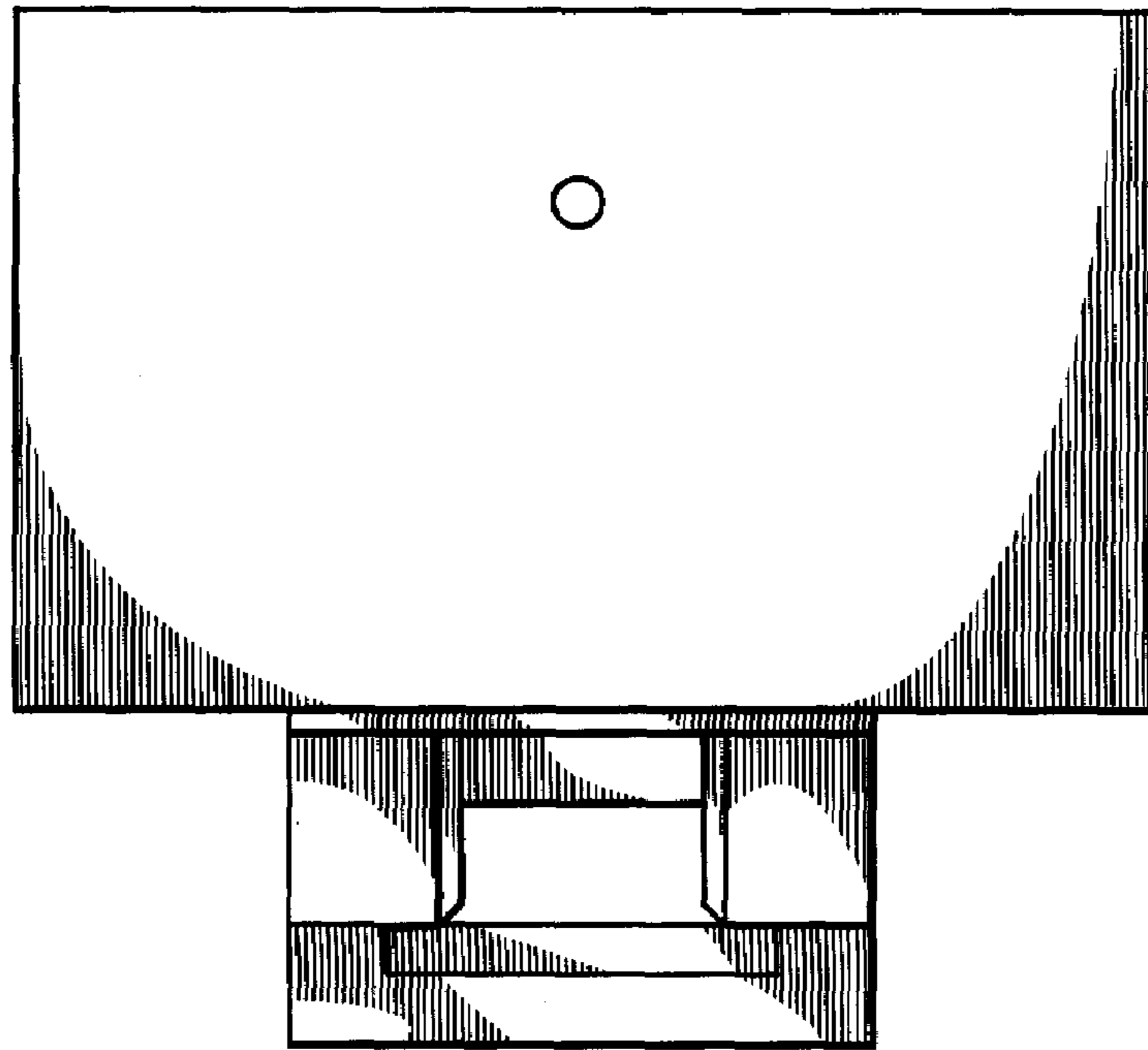

FIG. 31

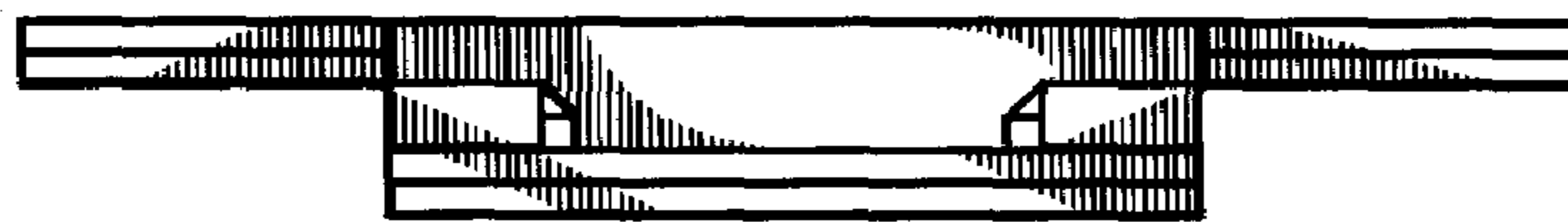

FIG. 32

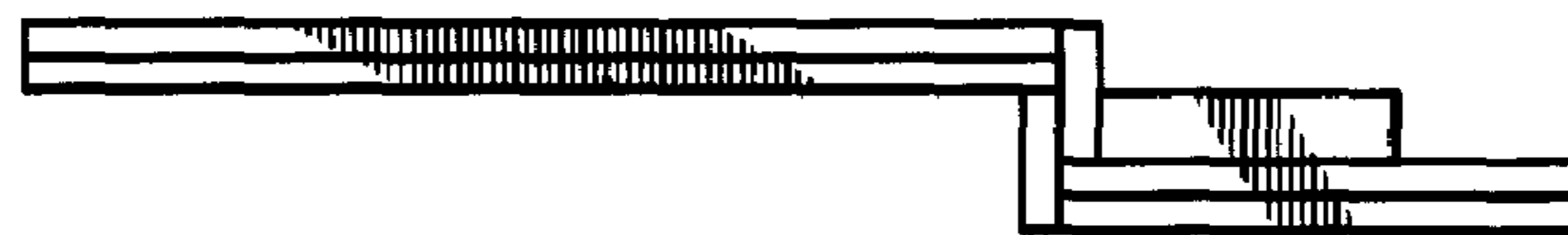

FIG. 33

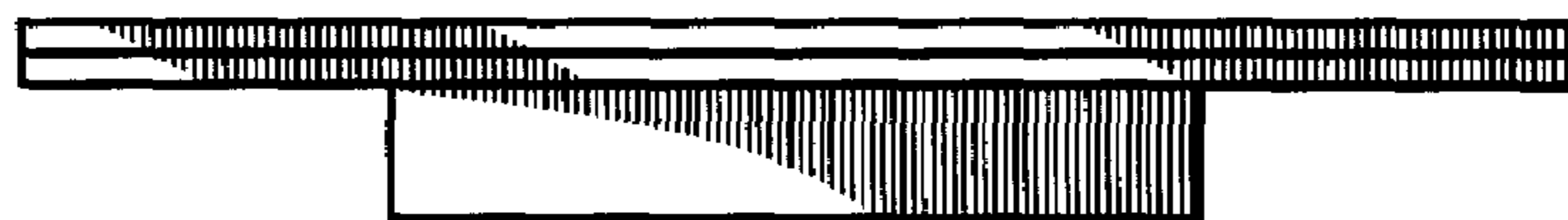

FIG. 34

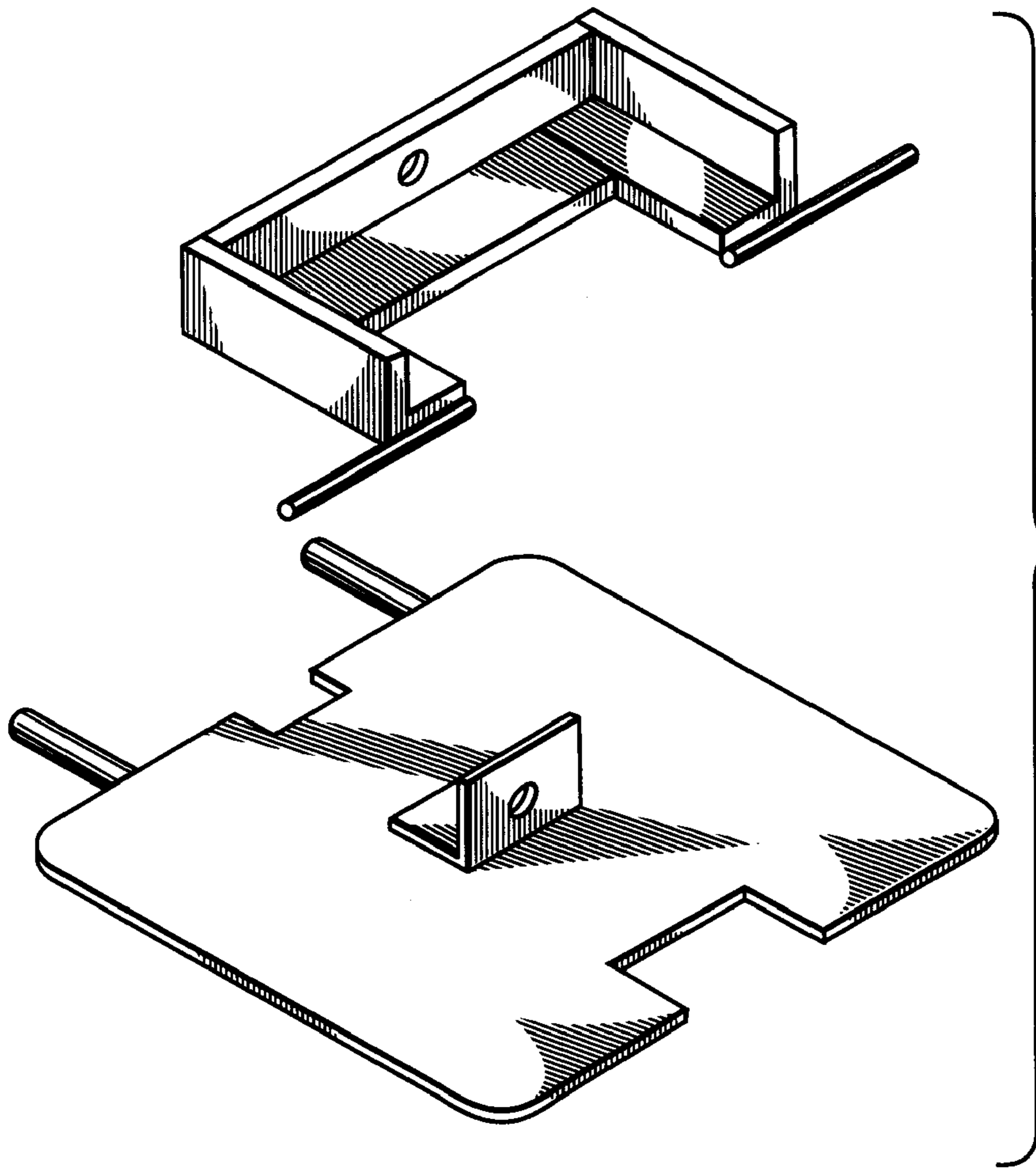

FIG. 35

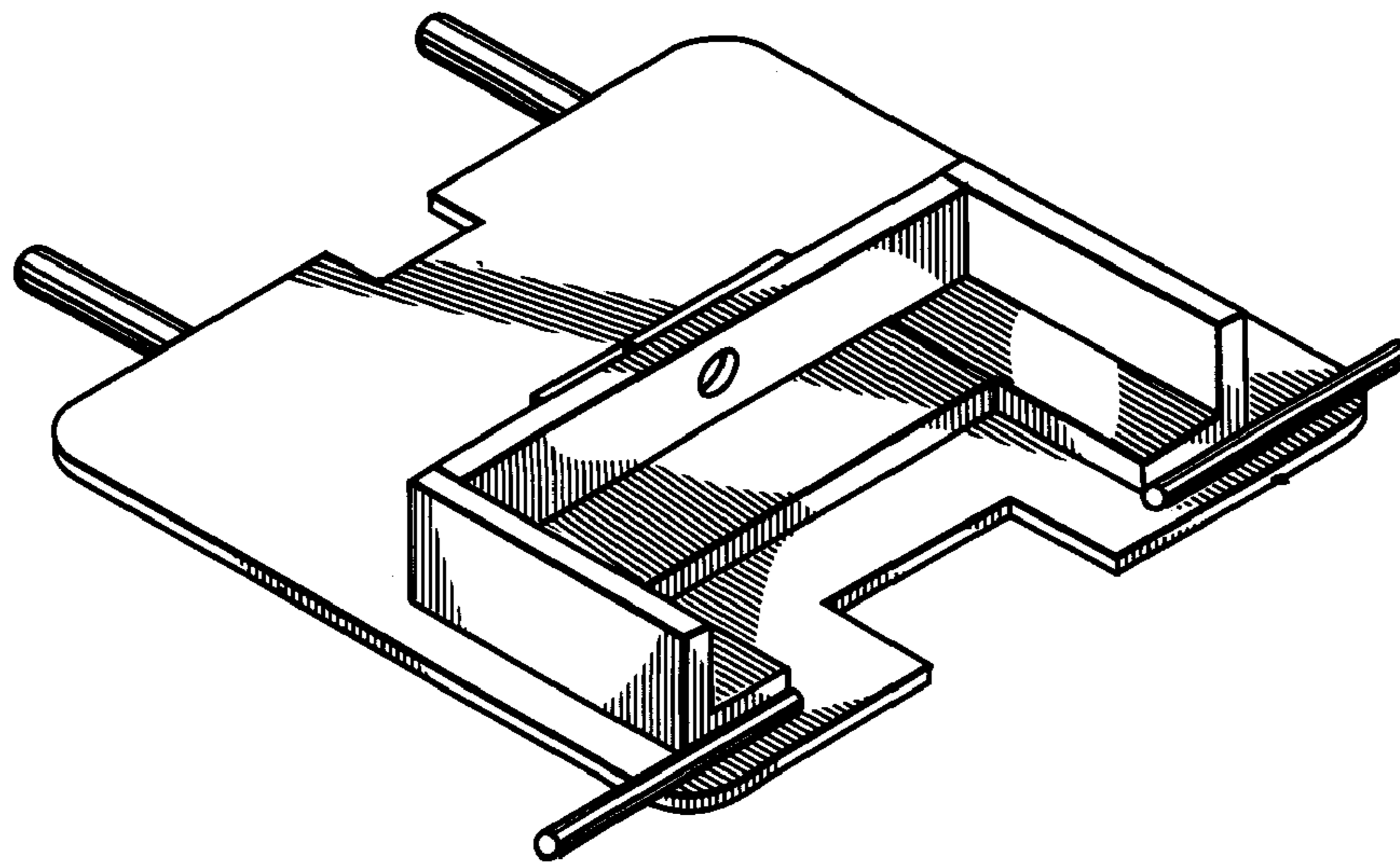

FIG. 36

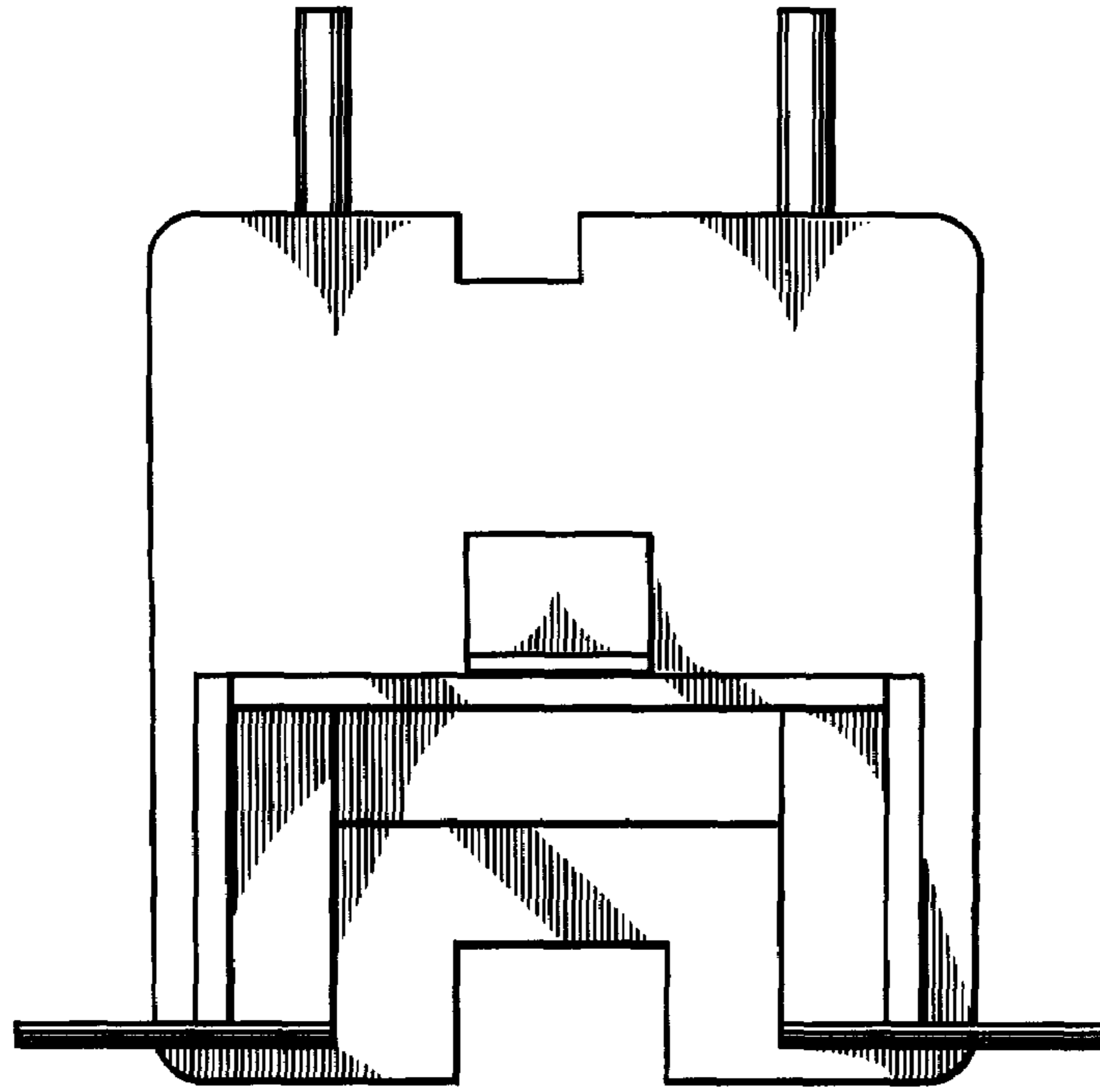

FIG. 37

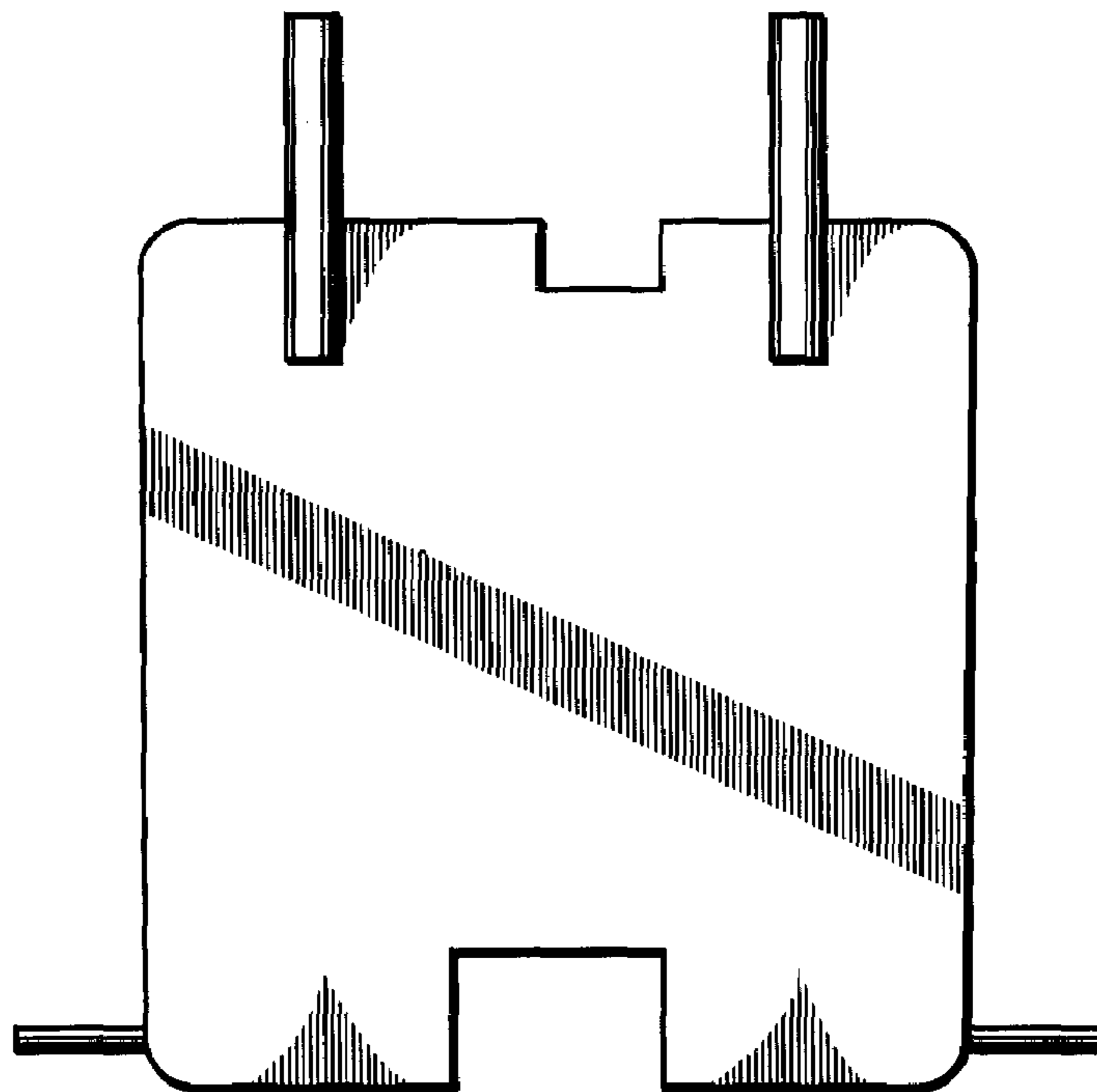

FIG. 38



FIG. 39

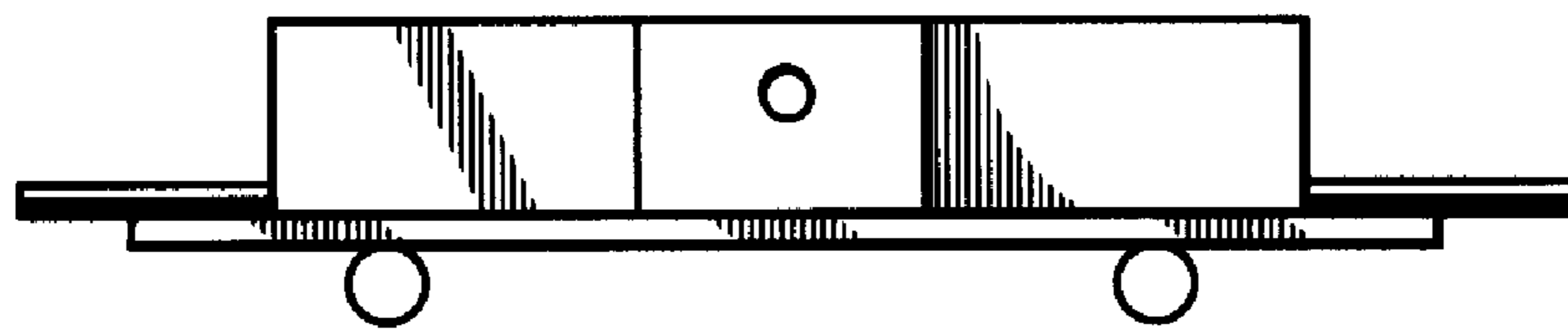

FIG. 40

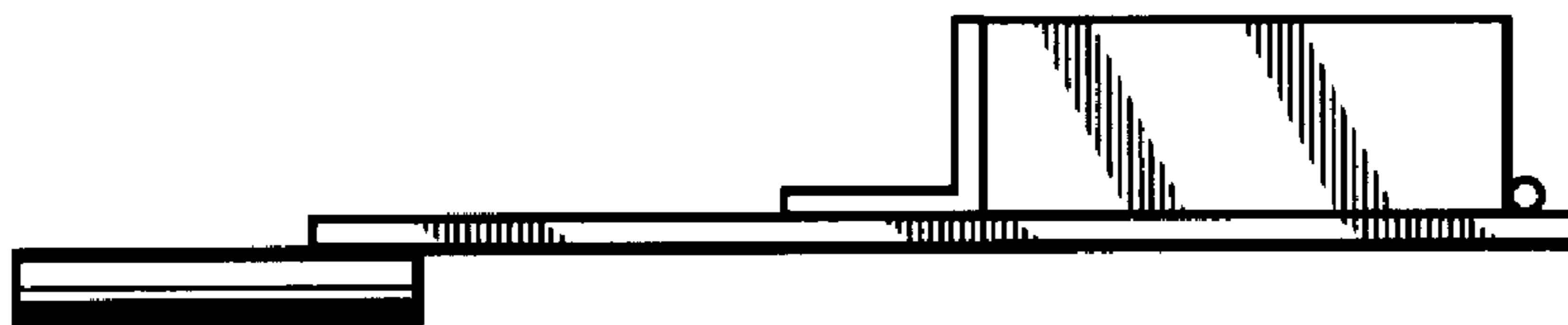

FIG. 41

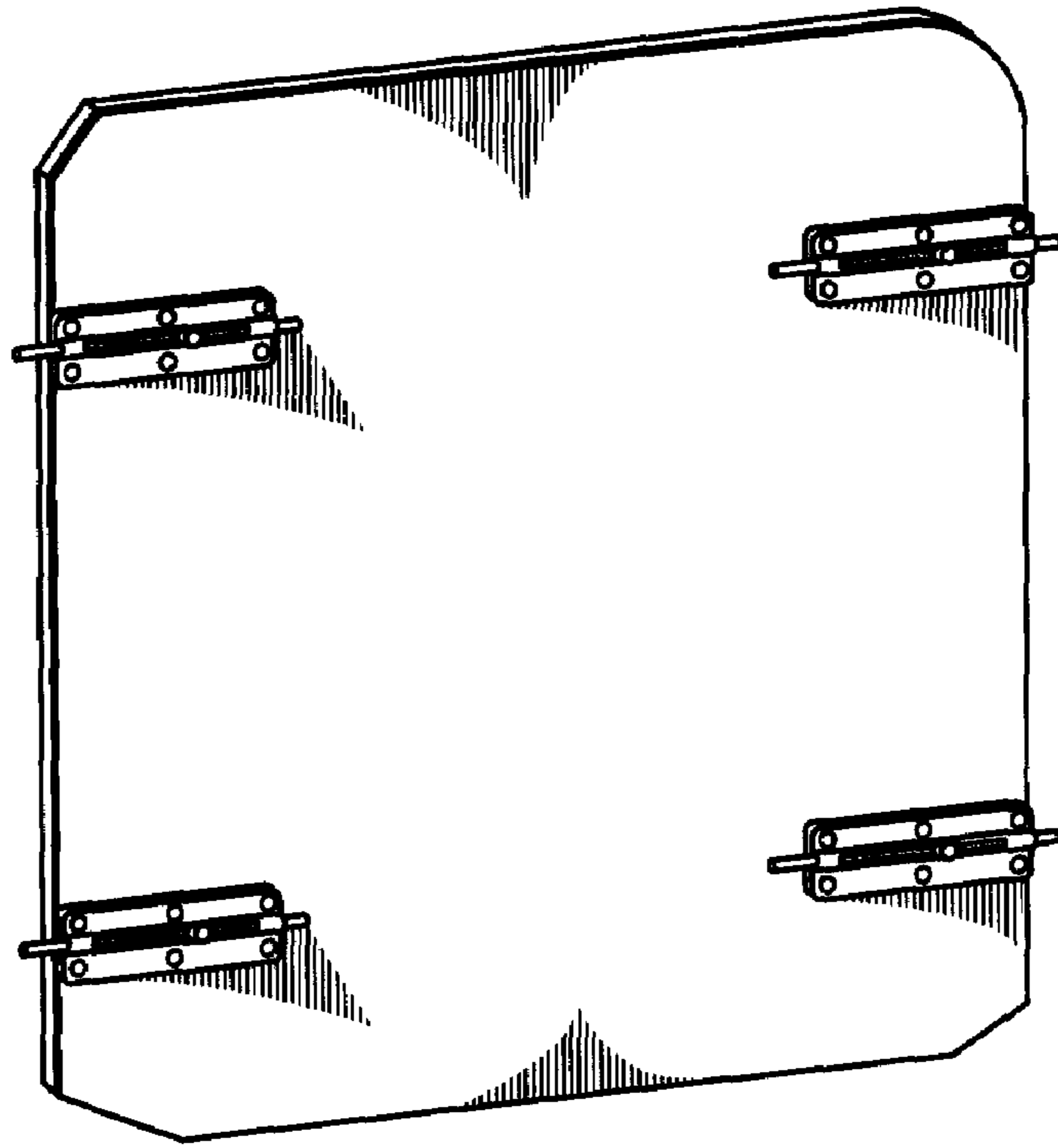

FIG. 42

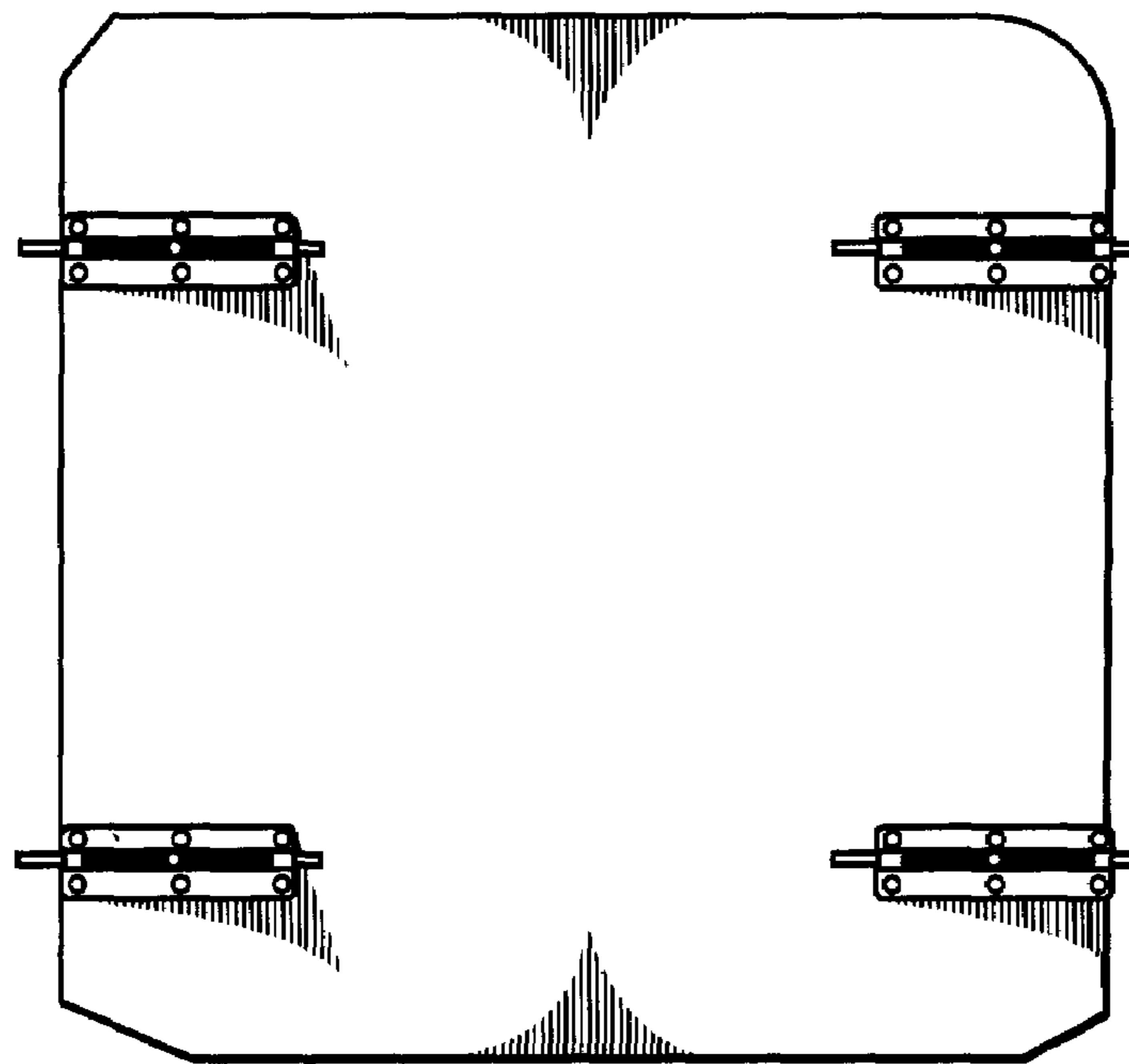

FIG. 43