

US00D549482S

(12) **United States Design Patent**
Natuzzi

(10) **Patent No.:** **US D549,482 S**

(45) **Date of Patent:** **** Aug. 28, 2007**

(54) **SOFA**

(75) **Inventor:** **Pasquale Natuzzi**, Santeramo in Colle
Bari (IT)

(73) **Assignee:** **Natuzzi, S.p.A.**, Bari (IT)

(**) **Term:** **14 Years**

(21) **Appl. No.:** **29/241,712**

(22) **Filed:** **Oct. 31, 2005**

(51) **LOC (8) Cl.** **06-01**

(52) **U.S. Cl.** **D6/381**

(58) **Field of Classification Search** D6/334-336,
D6/371, 381, 500-502, 349, 369, 370, 372,
D6/376, 379, 380; 297/232, 445.1, 451.3,
297/451.9; 5/12.1

See application file for complete search history.

(56) **References Cited**

U.S. PATENT DOCUMENTS

D298,391 S	*	11/1988	Quinn	D6/381
D314,473 S	*	2/1991	Culler	D6/367
D330,811 S	*	11/1992	Genova et al.	D6/381
D405,280 S	*	2/1999	Gibson	D6/335
D470,674 S	*	2/2003	Friedman	D6/381
D481,218 S	*	10/2003	Spinelli et al.	D6/381
D494,772 S	*	8/2004	Kagan	D6/381
D524,569 S	*	7/2006	Kevonian	D6/381
D527,540 S	*	9/2006	Kevonian	D6/381

OTHER PUBLICATIONS

Natuzzi sofa #991, International Home Furnishings Market, High Point, NC., Oct. 1992, 1 pg.*

* cited by examiner

Primary Examiner—Sandra Snapp

(74) *Attorney, Agent, or Firm*—Egbert Law Offices

(57) **CLAIM**

I claim the ornamental design for a sofa, as shown and described.

DESCRIPTION

FIG. 1 is a front perspective view of the sofa showing my design;

FIG. 2 is a back perspective view thereof;

FIG. 3 is a top plan view, showing armrests in an open position;

FIG. 4 is another top plan view, showing armrests in a closed position;

FIG. 5 is a front perspective view thereof;

FIG. 6 is a side view, showing armrests in an open position;

FIG. 7 is another side view, showing armrests in a closed position; and,

FIG. 8 is a side perspective view thereof, showing armrests in dotted lines illustrating a range of positioning of the armrests.

The broken lines shown on the sofa are understood to represent stitching. The dotted lines shown on the sofa are understood to show positioning of the armrests.

1 Claim, 5 Drawing Sheets

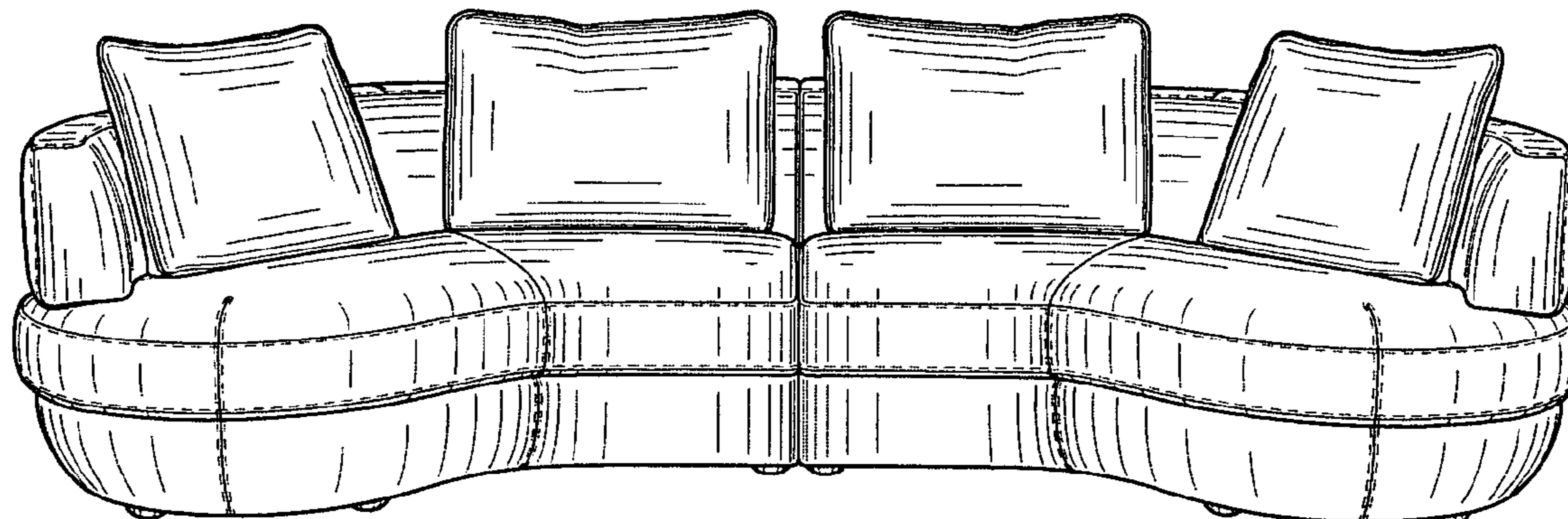

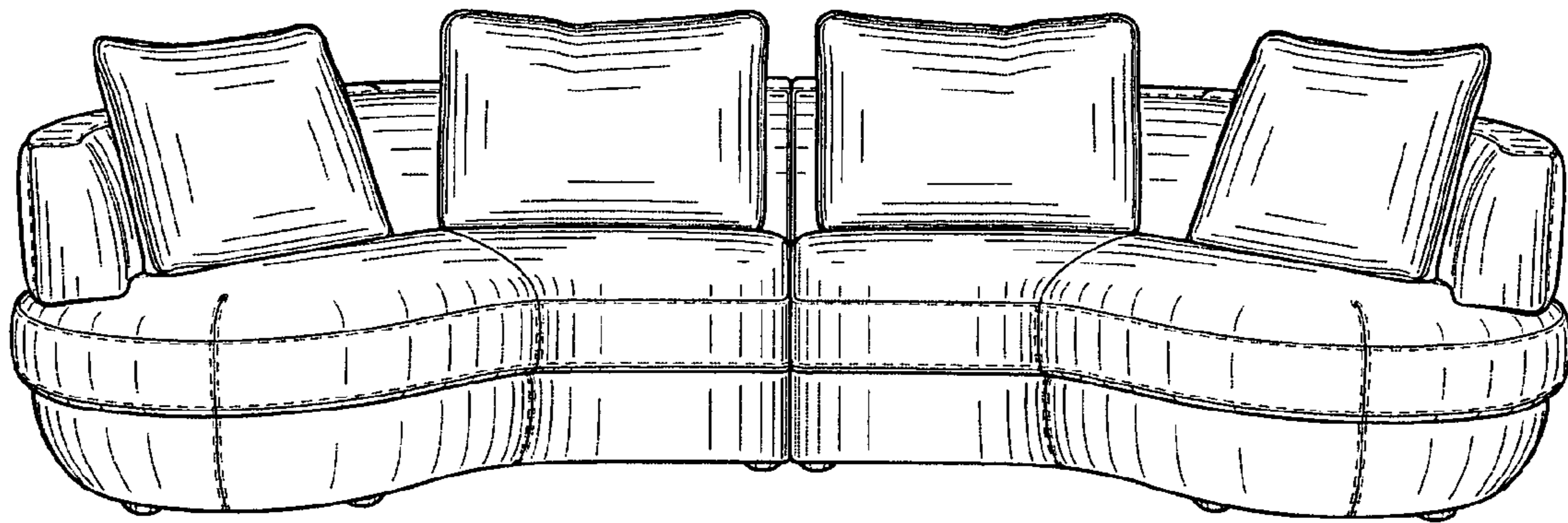

FIG. 1

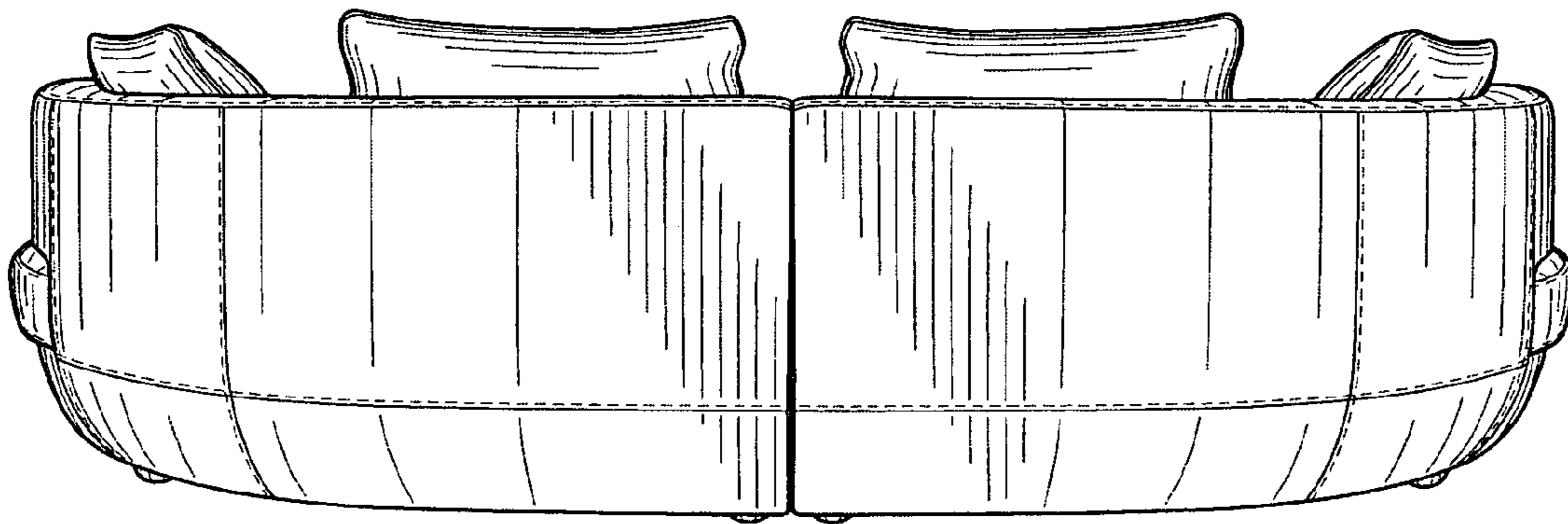

FIG. 2

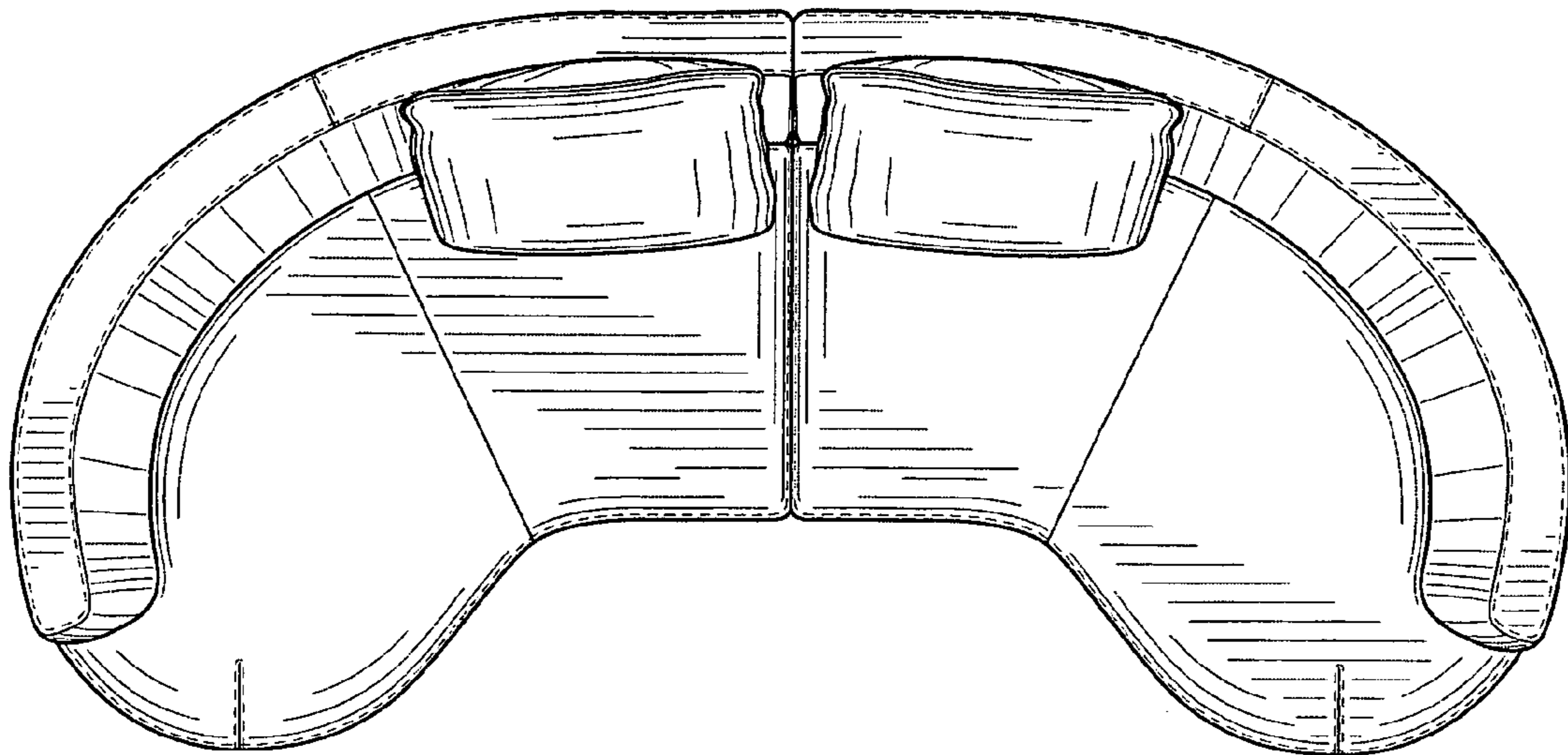

FIG. 3

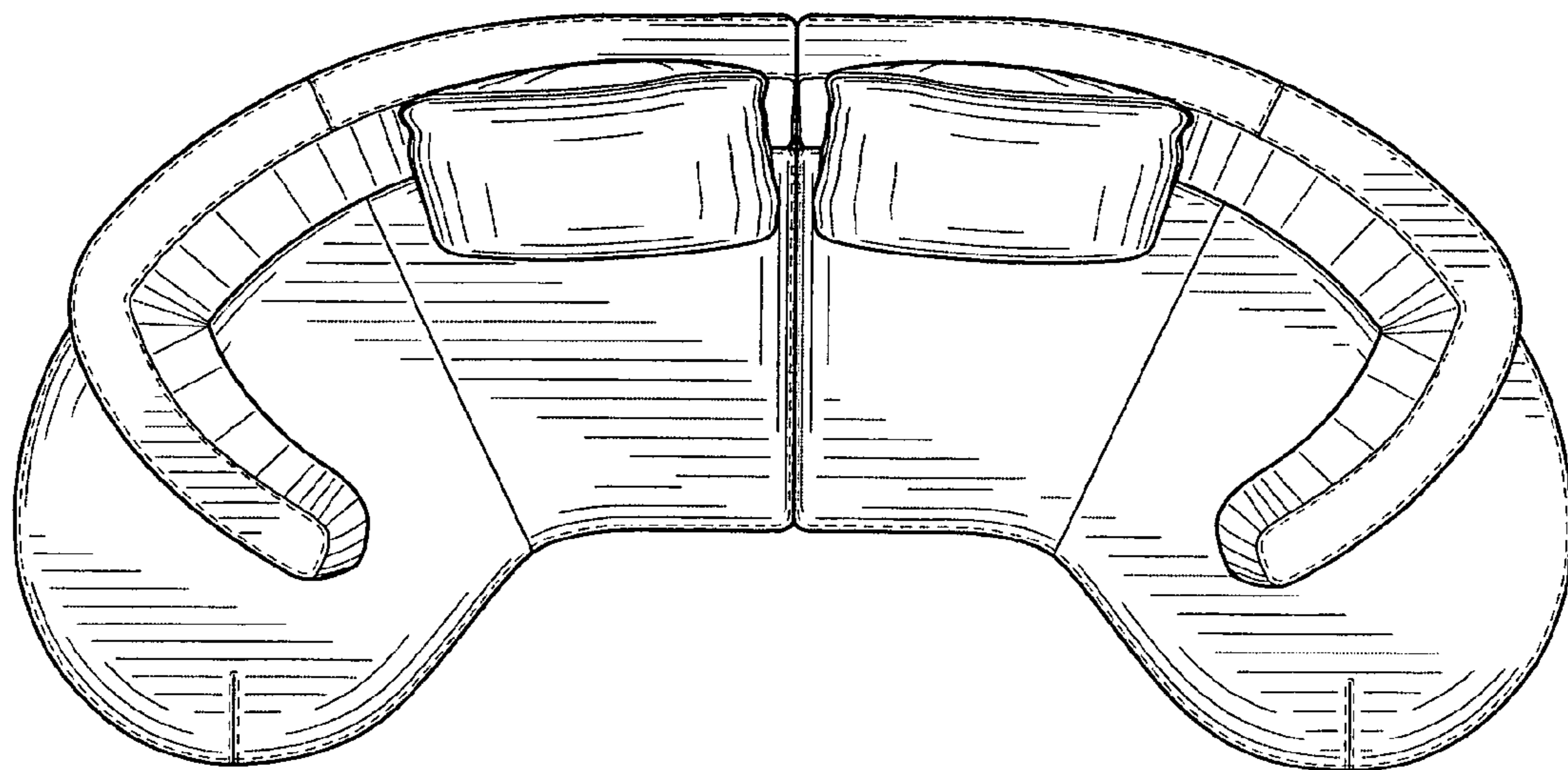

FIG. 4

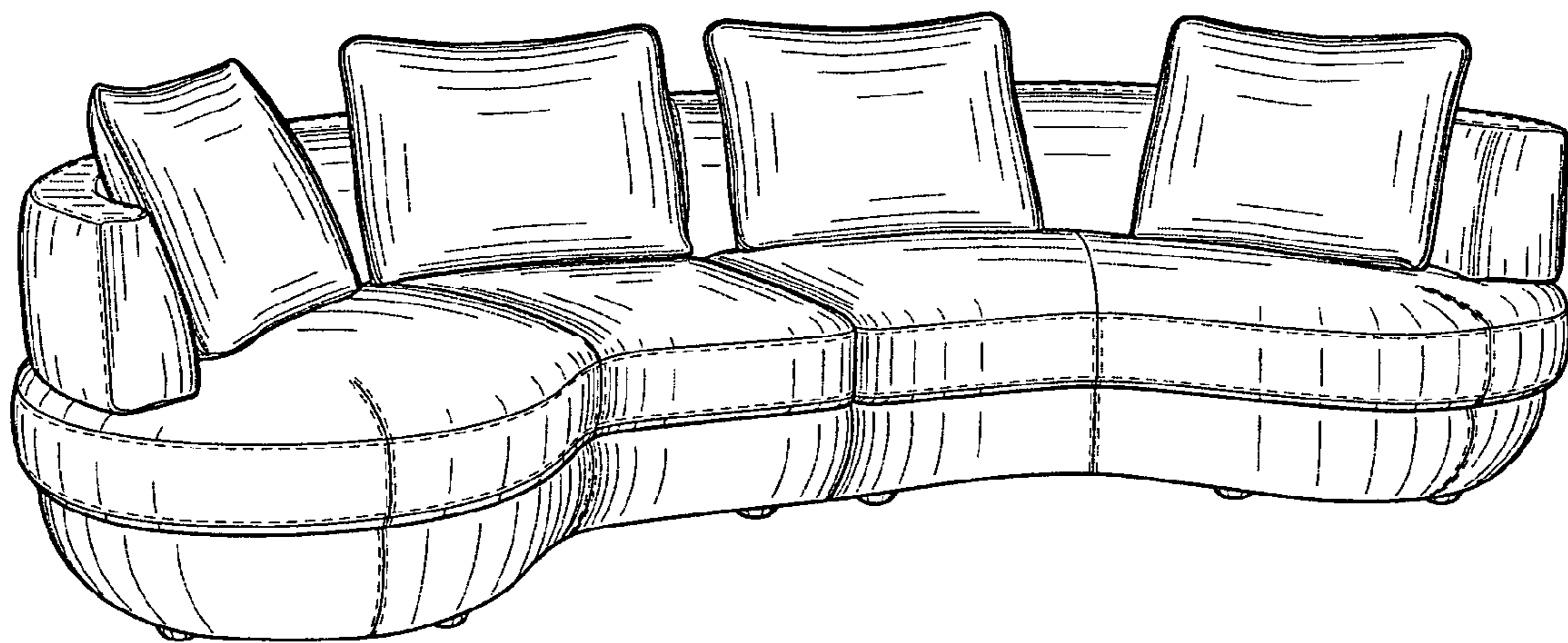

FIG. 5

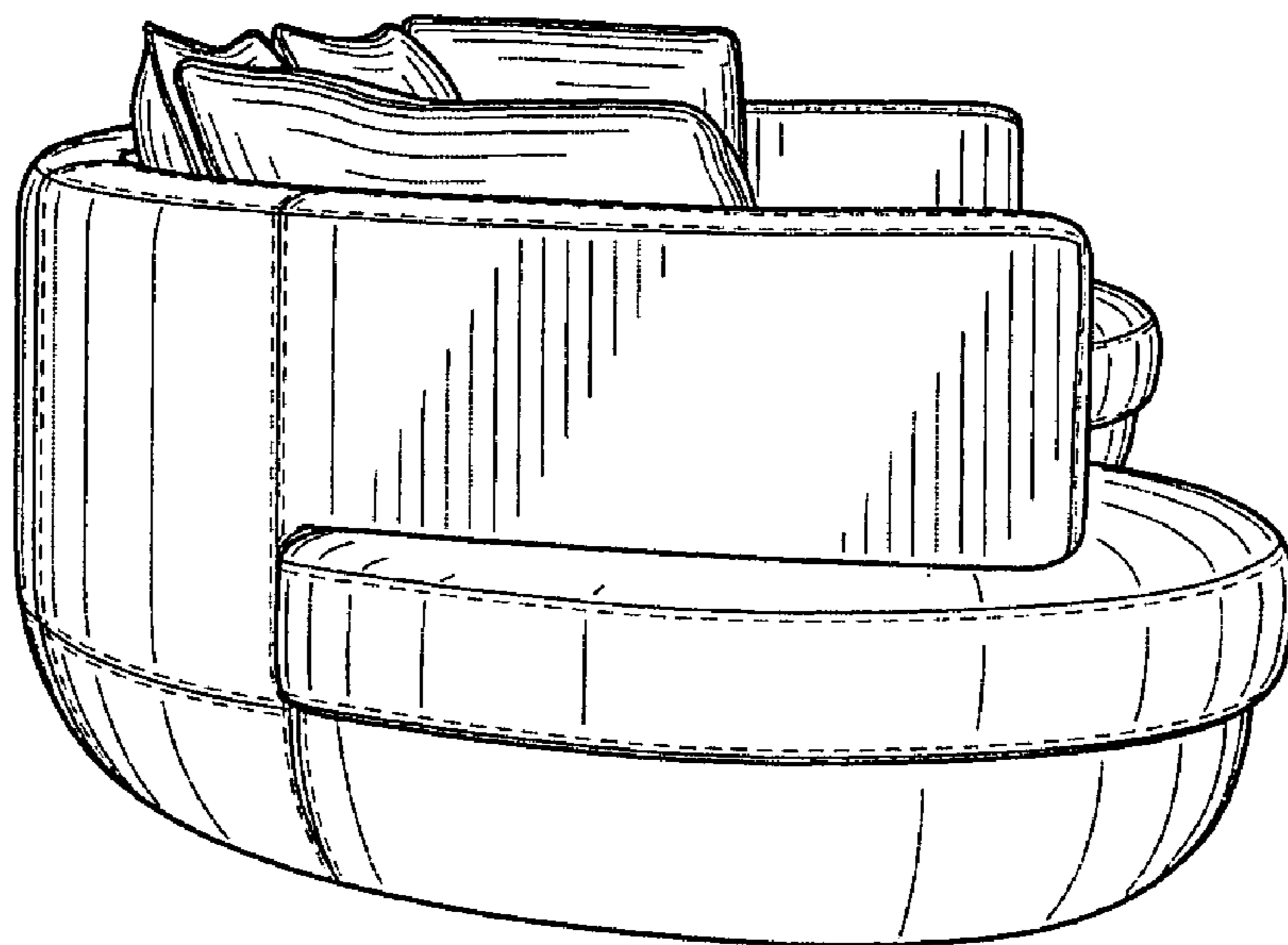

FIG. 6

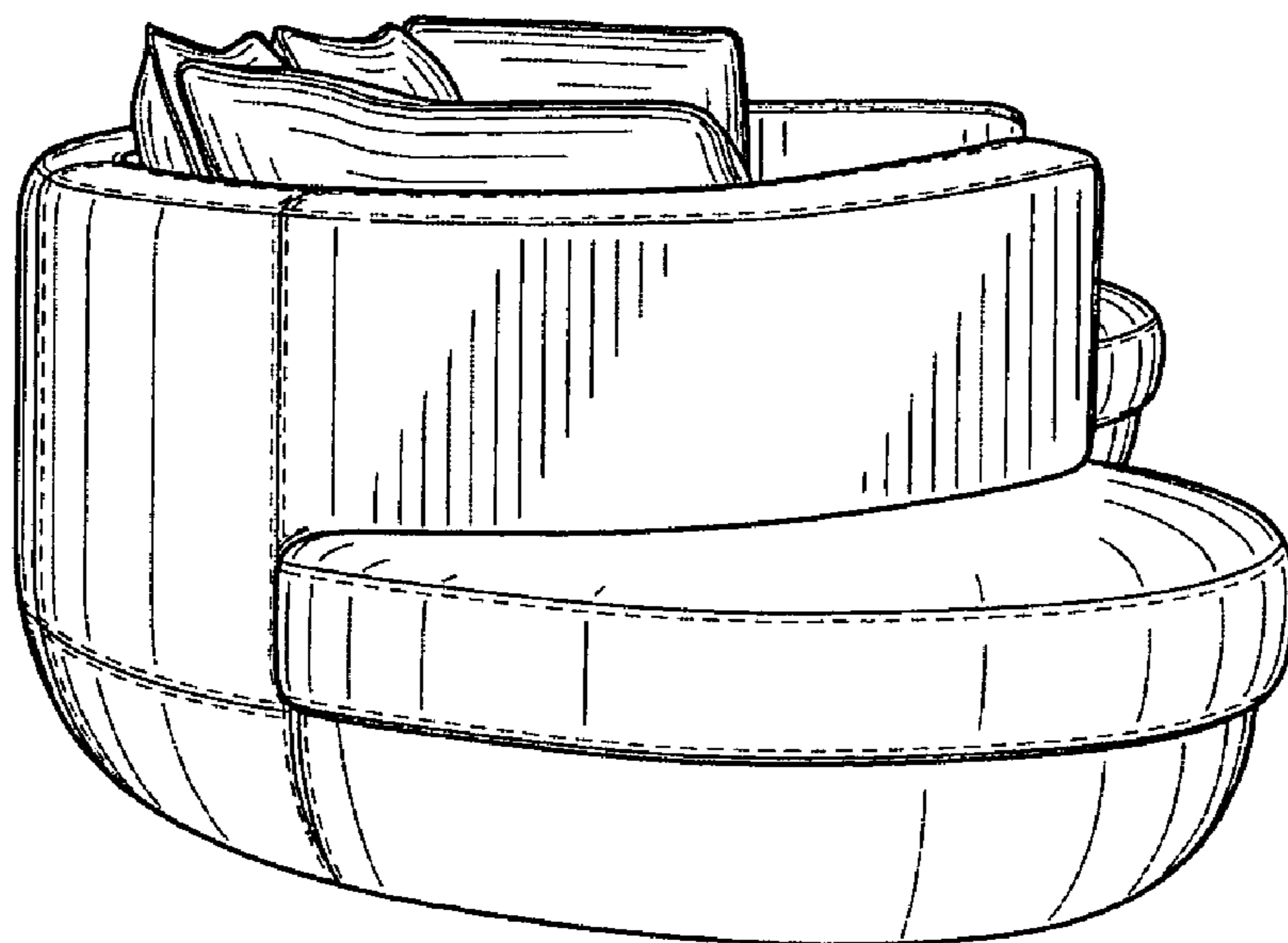

FIG. 7

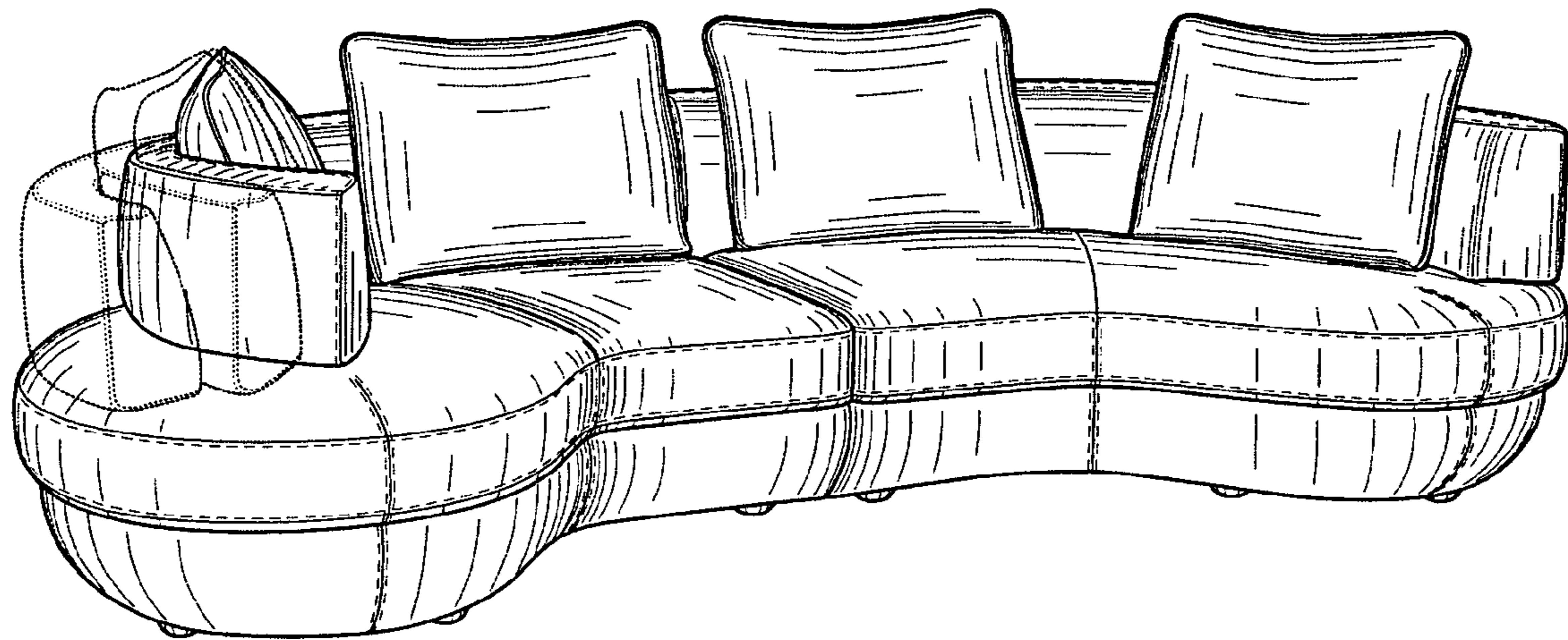

FIG. 8