



US00D549364S

(12) **United States Design Patent** (10) **Patent No.:** **US D549,364 S**
Hovind et al. (45) **Date of Patent:** **** Aug. 21, 2007**

(54) **VEHICLE INTERIOR LIGHT**

(57) **CLAIM**

(75) Inventors: **Steven H. Hovind**, Bellevue, WA (US);
Wallace A. Peltola, Sammamish, WA
(US); **Andy King-Pui Wong**, Seattle,
WA (US)

The ornamental design for a vehicle interior light, as shown
and described.

(73) Assignee: **PACCAR Inc**, Bellevue, WA (US)

DESCRIPTION

(**) Term: **14 Years**

FIG. 1 is a front perspective view of the top of a vehicle
interior light showing our new design;

(21) Appl. No.: **29/276,207**

FIG. 2 is a front perspective view of the bottom of the
vehicle interior light of FIG. 1

(22) Filed: **Jan. 18, 2007**

FIG. 3 is a top plan view of the vehicle interior light of FIG.
1;

(51) **LOC (8) Cl.** **26-06**

(52) **U.S. Cl.** **D26/28**

(58) **Field of Classification Search** D26/28-36;
362/61, 74, 80, 83, 216-224, 404, 432
See application file for complete search history.

FIG. 4 is a bottom plan view of the vehicle interior light of
FIG. 1;

(56) **References Cited**

U.S. PATENT DOCUMENTS

D426,329 S * 6/2000 Wang Cheng D26/28

D435,126 S * 12/2000 Abry D26/28

D457,981 S * 5/2002 Yeh D26/76

D467,367 S * 12/2002 Campagna D26/28

FIG. 5 is a right side elevational view of the vehicle interior
light of FIG. 1;

FIG. 6 is a front elevational view of the vehicle interior light
of FIG. 1;

FIG. 7 is a left side elevational view of the vehicle interior
light of FIG. 1; and,

FIG. 8 is a rear elevational view of the vehicle interior light
of FIG. 1.

* cited by examiner

The broken lines in the drawings form no part of the claimed
design.

Primary Examiner—Marcus A. Jackson

(74) *Attorney, Agent, or Firm*—Christensen O'Connor;
Johnson Kindness PLLC

1 Claim, 3 Drawing Sheets

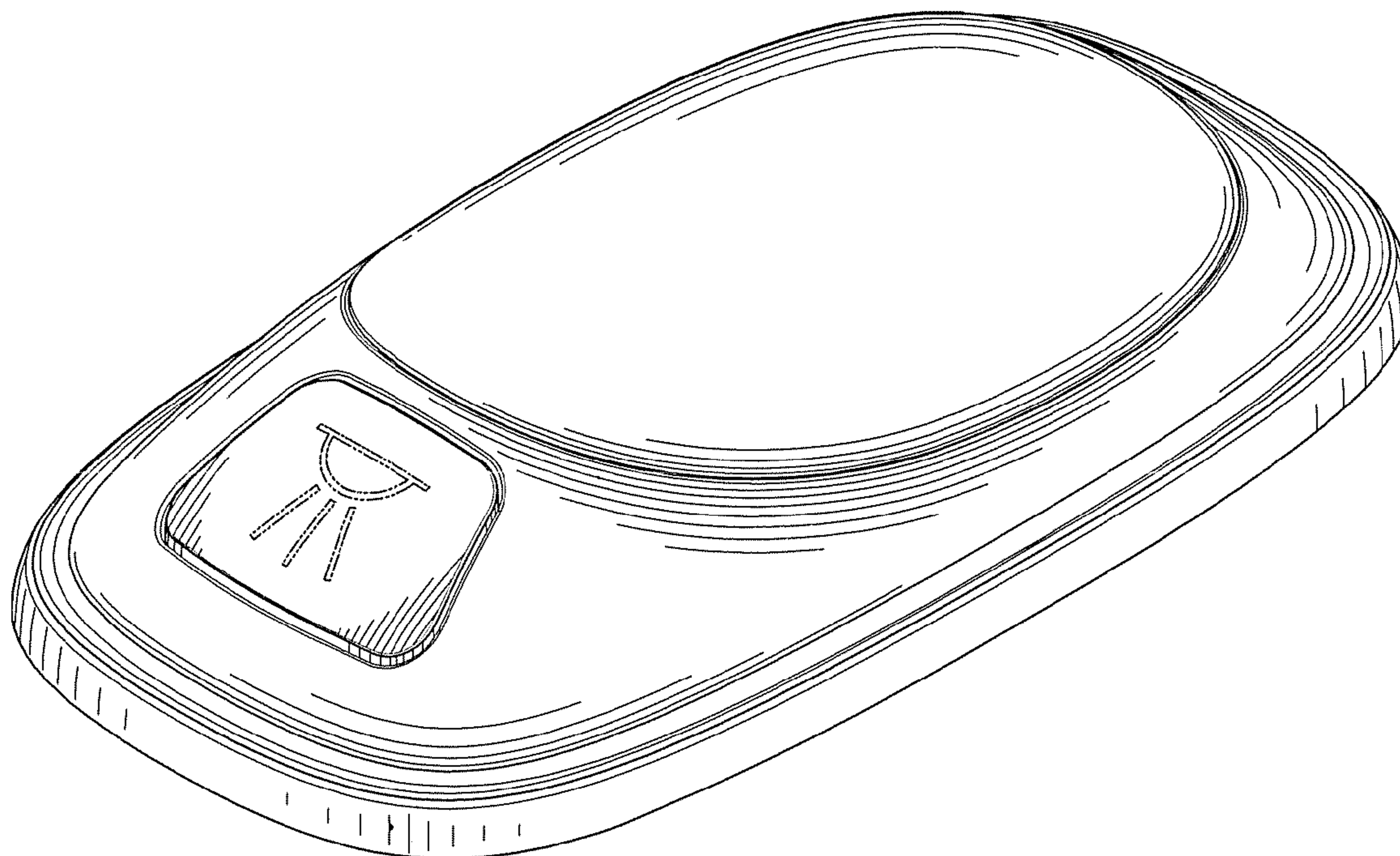

Fig. 1.

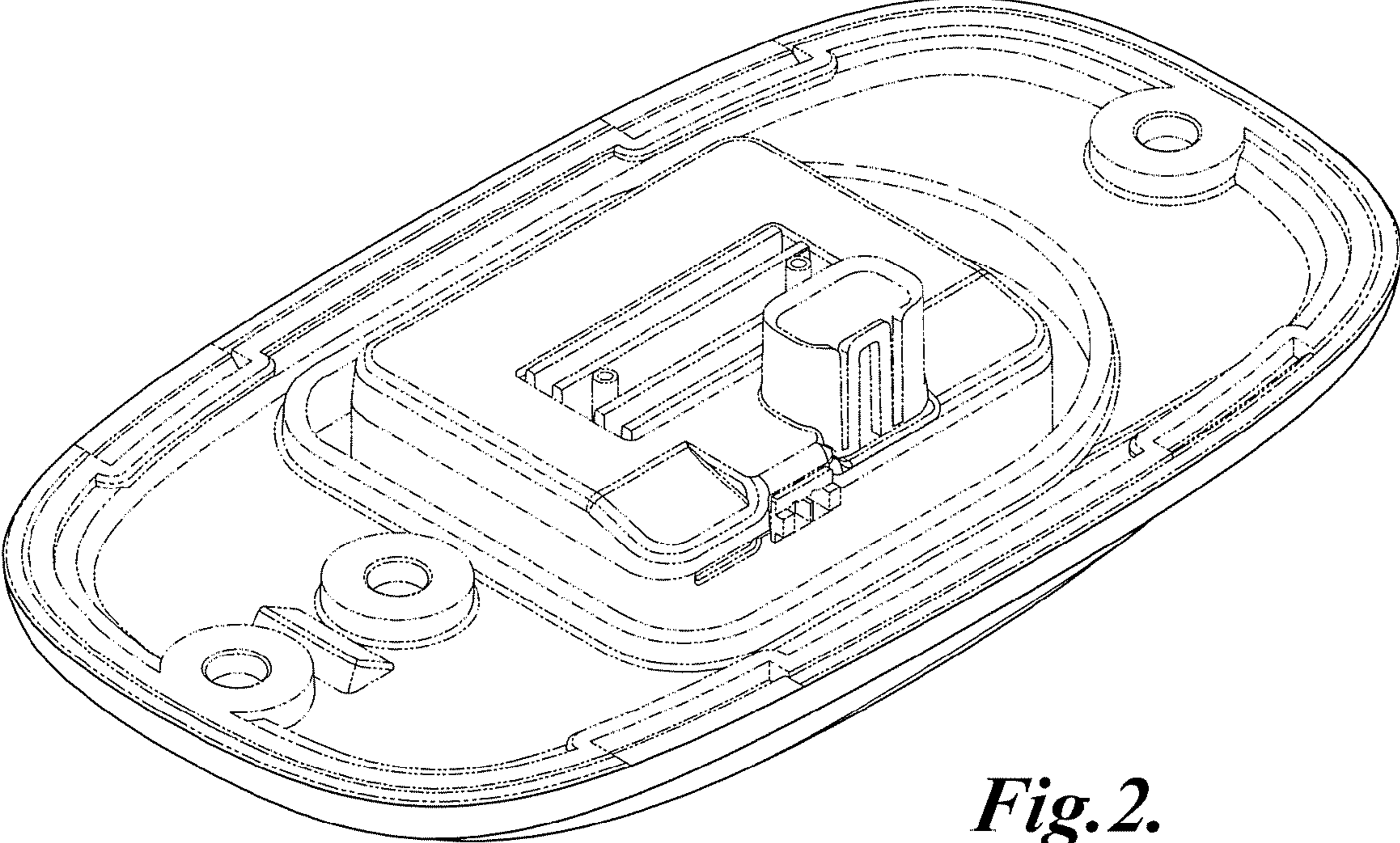
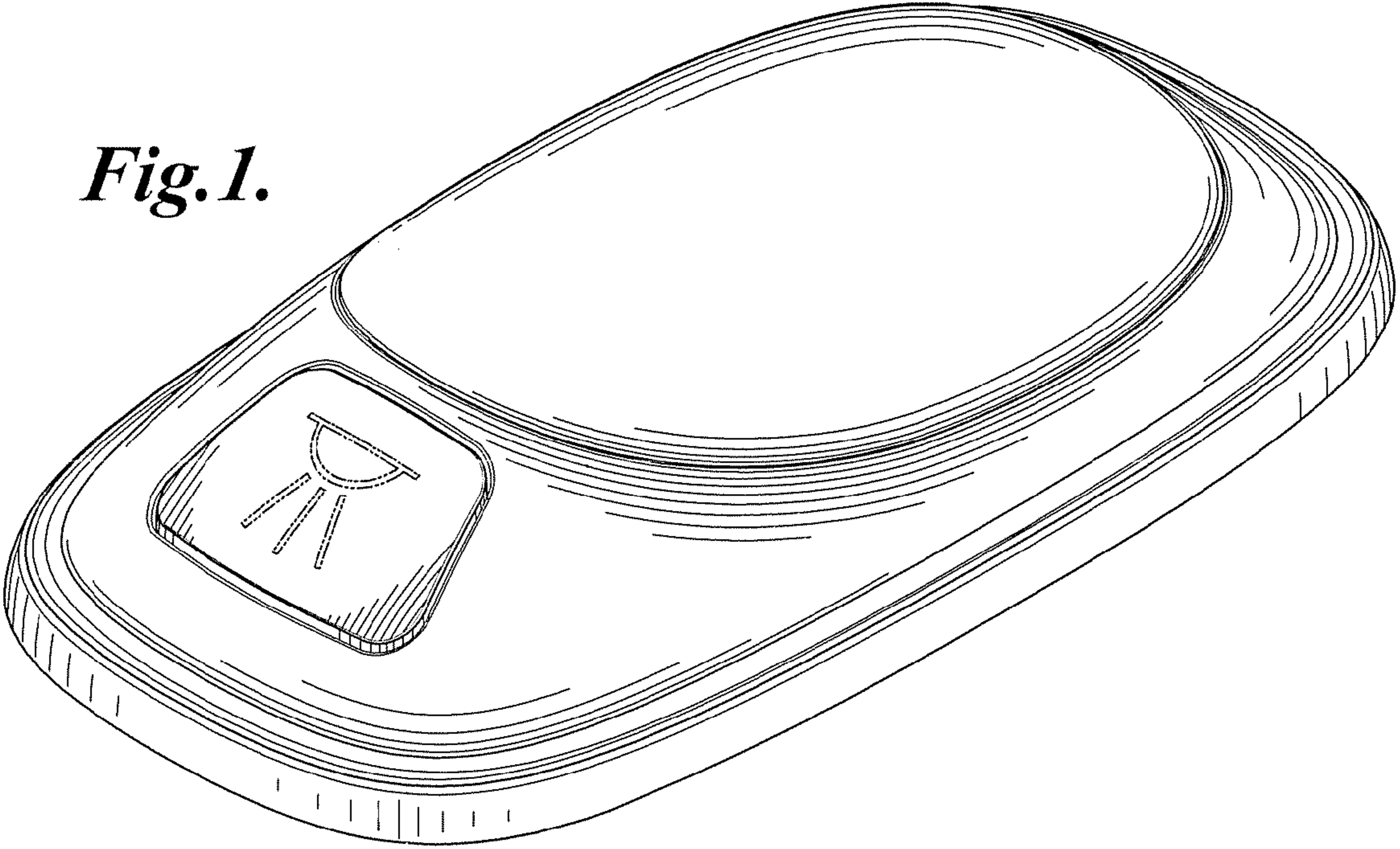

Fig. 2.

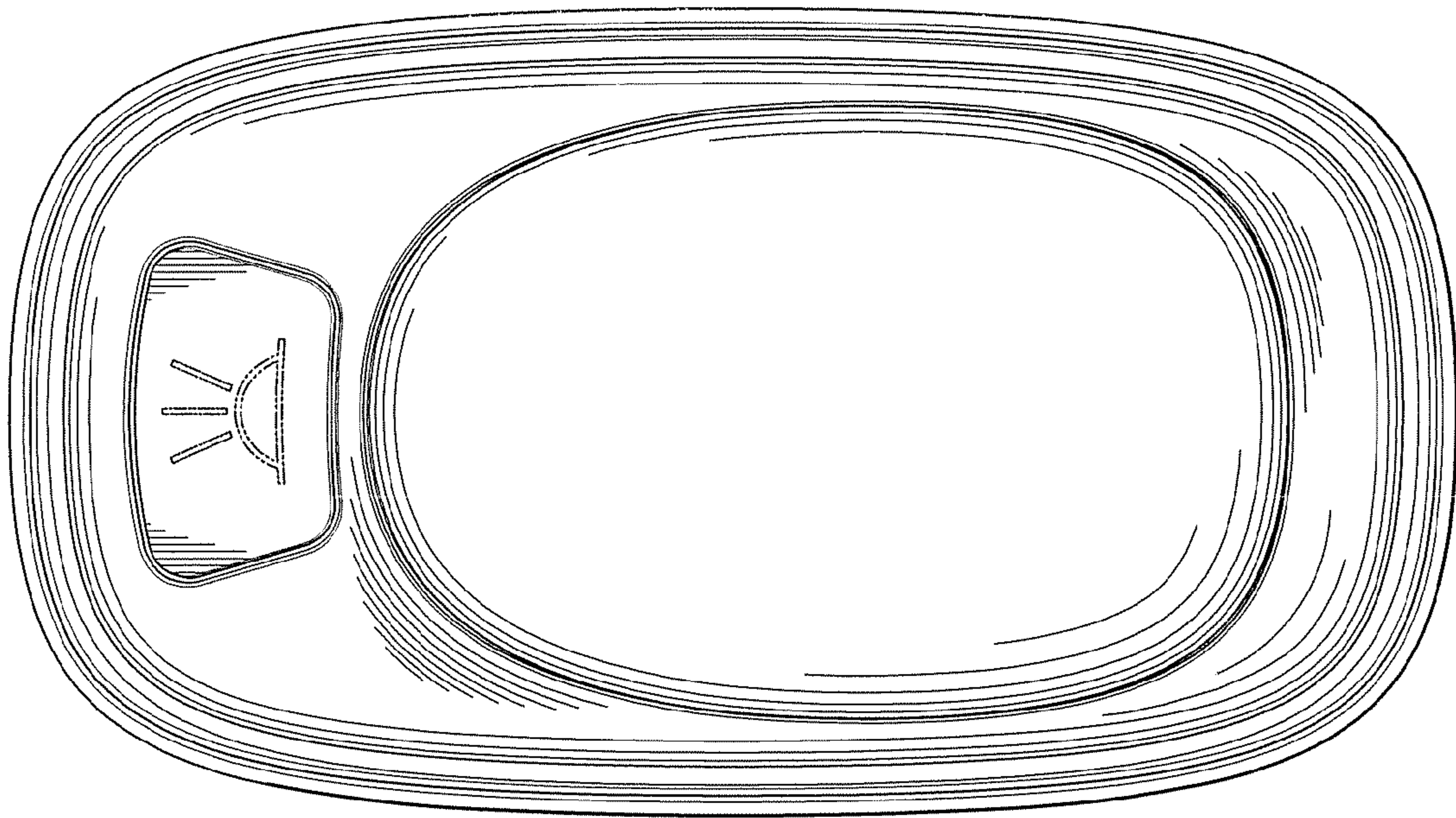

Fig.3.

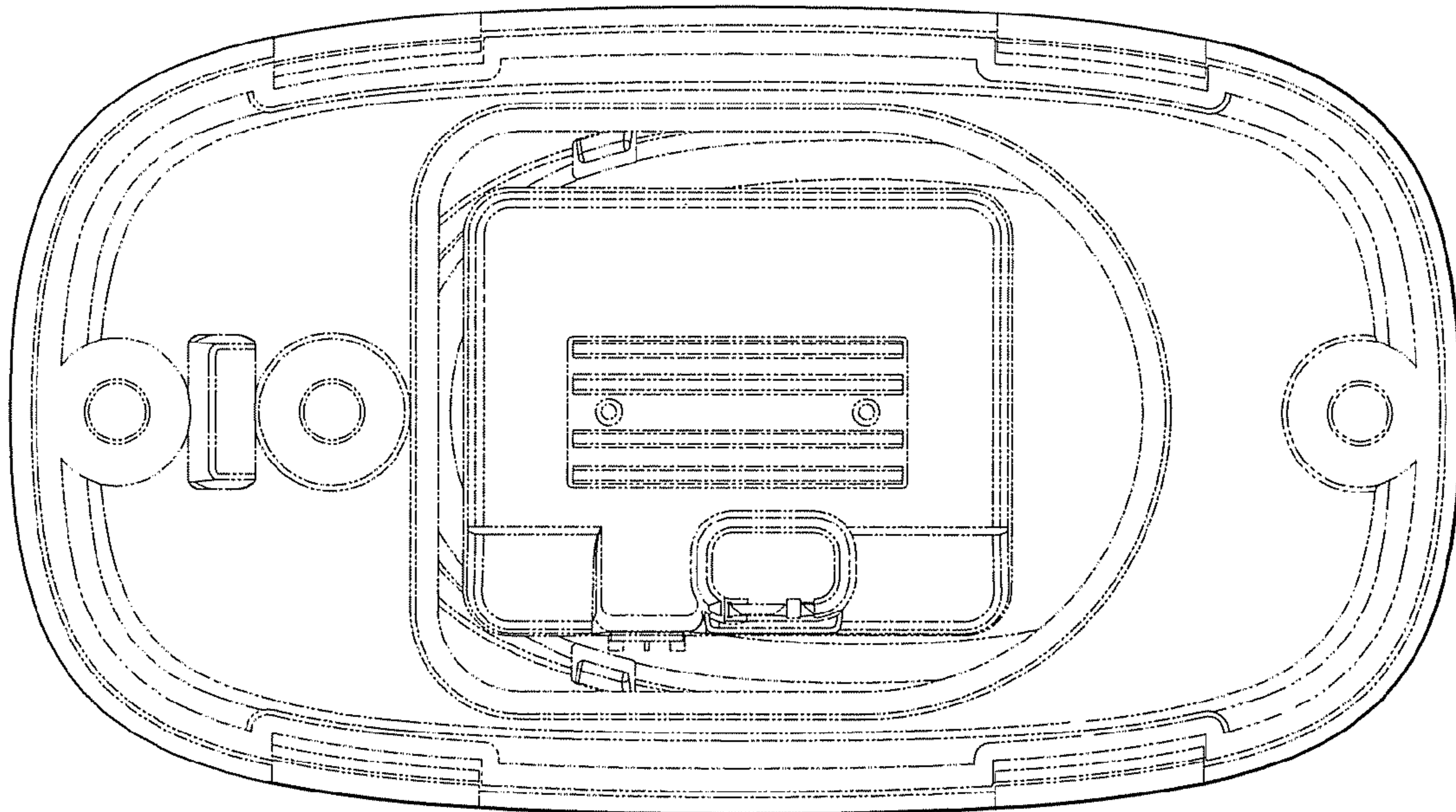

Fig.4.

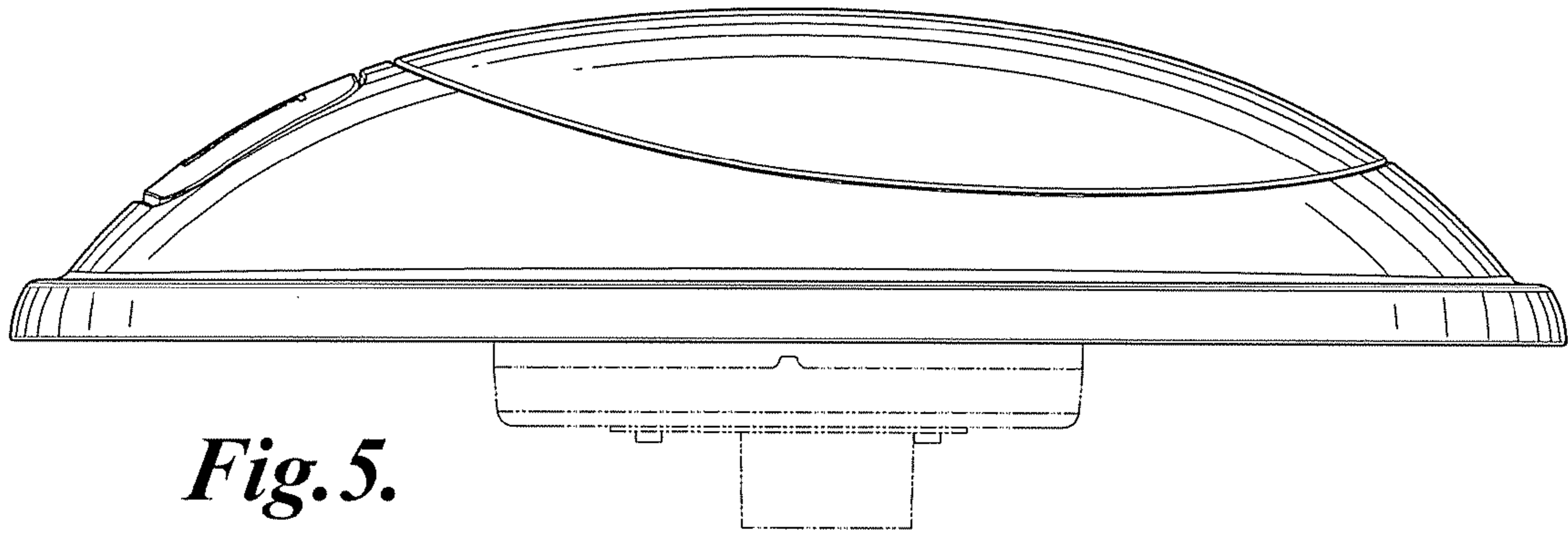

Fig. 5.

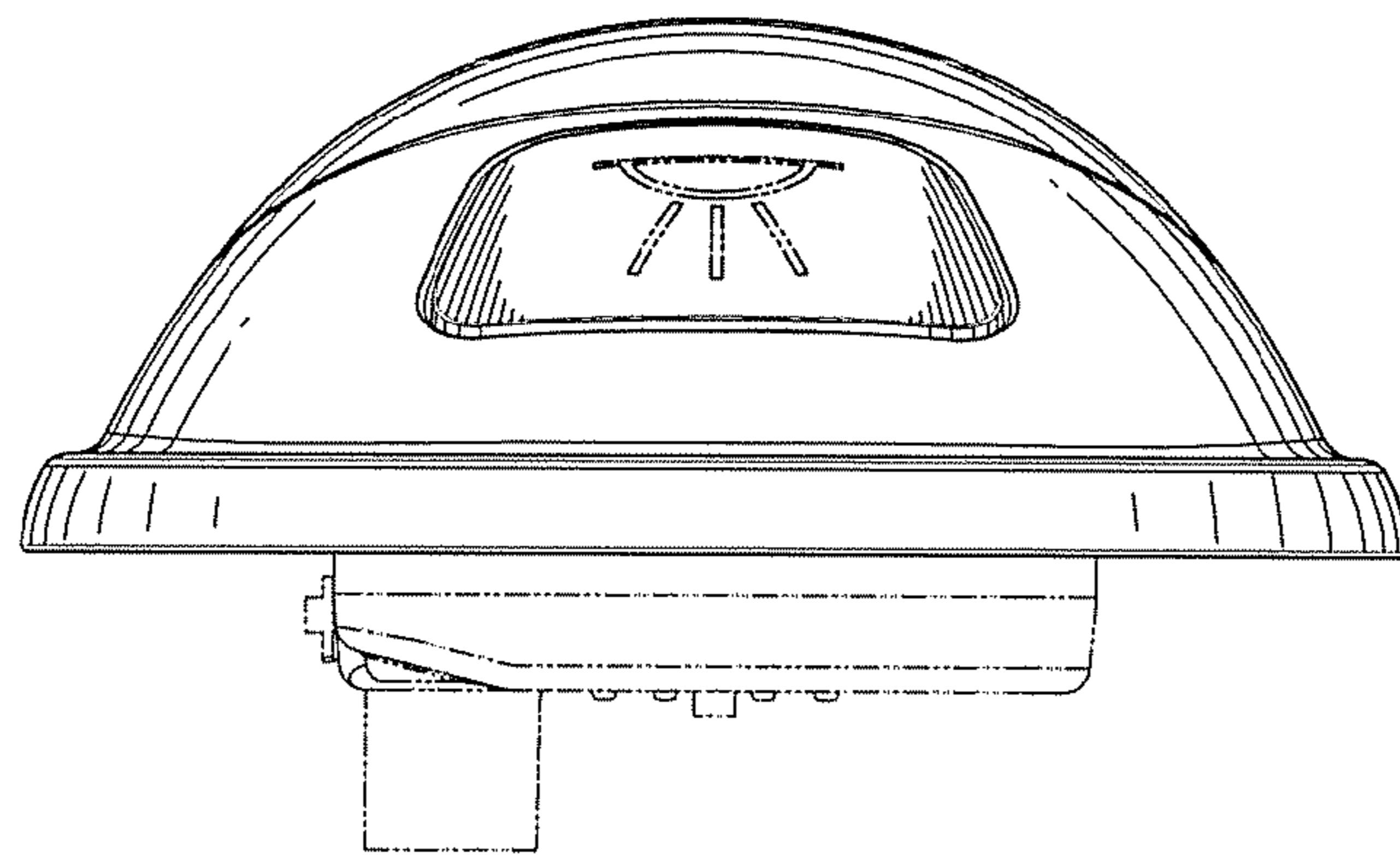

Fig. 6.

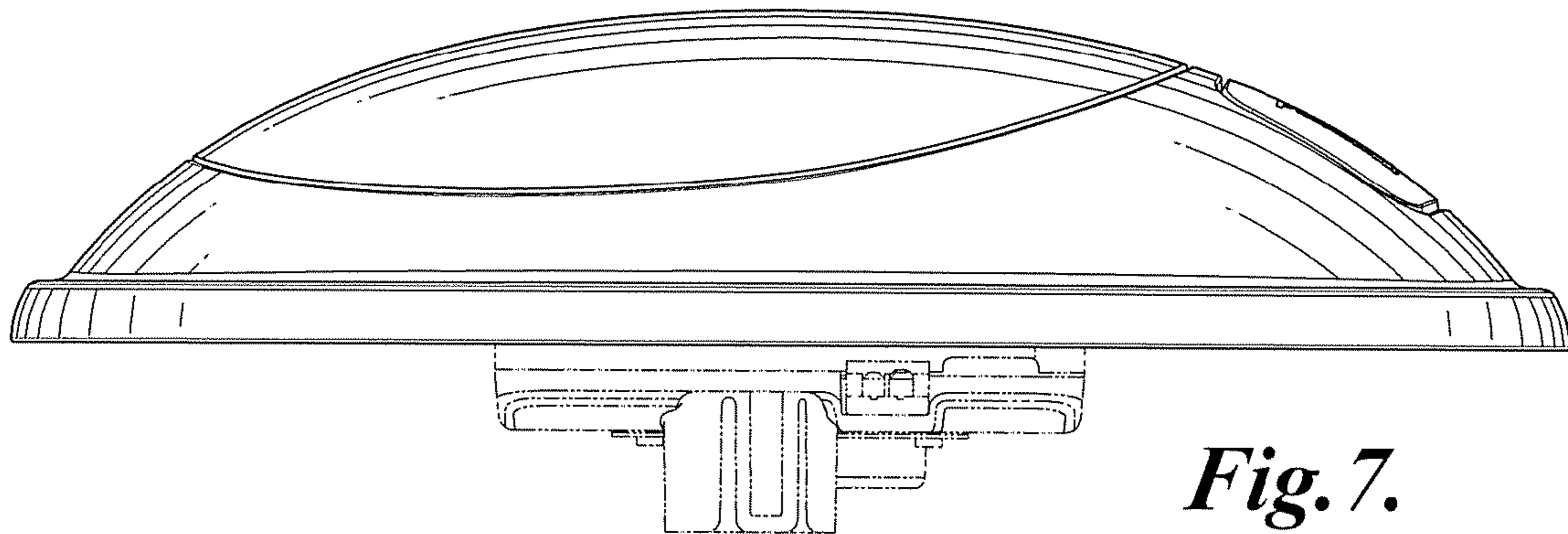

Fig. 7.

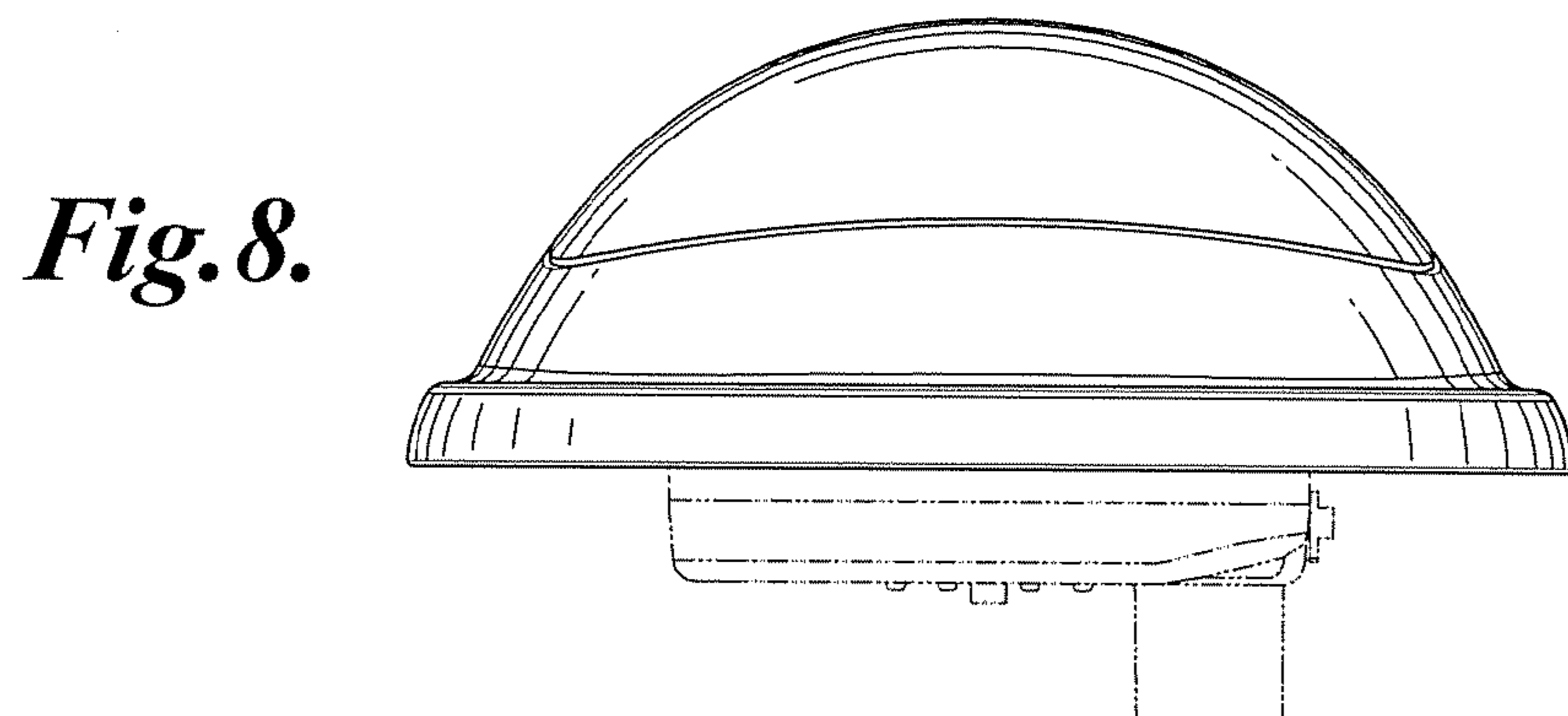

Fig. 8.