

US00D548723S

(12) **United States Design Patent**  
**Mizokawa**

(10) **Patent No.:** **US D548,723 S**

(45) **Date of Patent:** **\*\* Aug. 14, 2007**

(54) **AMPLIFIER FOR AN AUTOMOBILE**

D504,671 S 5/2005 Hasbrook et al.

D505,402 S 5/2005 Wong

(75) Inventor: **Hiroyuki Mizokawa**, Osaka (JP)

D512,707 S \* 12/2005 Chen et al. .... D14/188

(73) Assignee: **Matsushita Electric Industrial Co., Ltd.**, Osaka (JP)

**FOREIGN PATENT DOCUMENTS**

(\*\*) Term: **14 Years**

JP D1149920 8/2002

JP D1178411 7/2003

JP D1226016 12/2004

JP D1241959 6/2005

JP D1241960 6/2005

JP D1243275 6/2005

(21) Appl. No.: **29/258,420**

(22) Filed: **Apr. 21, 2006**

\* cited by examiner

(30) **Foreign Application Priority Data**

Dec. 2, 2005 (JP) ..... 2005-035674

*Primary Examiner*—Stella Reid

*Assistant Examiner*—Keli' L. Acker

(51) **LOC (8) Cl.** ..... **14-03**

(52) **U.S. Cl.** ..... **D14/188**

(58) **Field of Classification Search** ..... D14/168,  
D14/169, 179, 188, 192–198, 217, 265, 299;  
330/1 R, 3, 4, 250; 381/86, 120; 455/344–351  
See application file for complete search history.

(74) *Attorney, Agent, or Firm*—Brinks Hofer Gilson & Lione

(57) **CLAIM**

I claim the ornamental design for an amplifier for an automobile, as shown and described.

(56) **References Cited**

**DESCRIPTION**

**U.S. PATENT DOCUMENTS**

D322,069 S \* 12/1991 Seror ..... D14/188

D343,394 S 1/1994 Kakizaki

5,285,500 A 2/1994 Mantz

D367,081 S \* 2/1996 Leveridge ..... D21/332

D386,178 S \* 11/1997 Frederick et al. .... D14/188

D396,720 S \* 8/1998 Yuyama ..... D14/188

D416,558 S \* 11/1999 Harrington ..... D14/188

D416,904 S \* 11/1999 Rabbani ..... D14/188

D419,156 S \* 1/2000 Yamazaki ..... D14/188

D423,502 S \* 4/2000 Lanclos ..... D14/188

D430,137 S \* 8/2000 Park ..... D14/188

D477,586 S 7/2003 Sogabe

D480,071 S 9/2003 Lum

D482,673 S 11/2003 Shindo

D502,170 S 2/2005 Lum

FIG. 1 is a top perspective view of an amplifier for an automobile of the present invention;

FIG. 2 is a front view thereof;

FIG. 3 is a side view thereof;

FIG. 4 is a side view thereof, opposite that shown in FIG. 3;

FIG. 5 is a top view thereof;

FIG. 6 is a rear view thereof; and,

FIG. 7 is a bottom view thereof.

The broken line showing of the amplifier for an automobile is included for the purpose of illustrating environmental and forms no part of the claimed design.

**1 Claim, 4 Drawing Sheets**

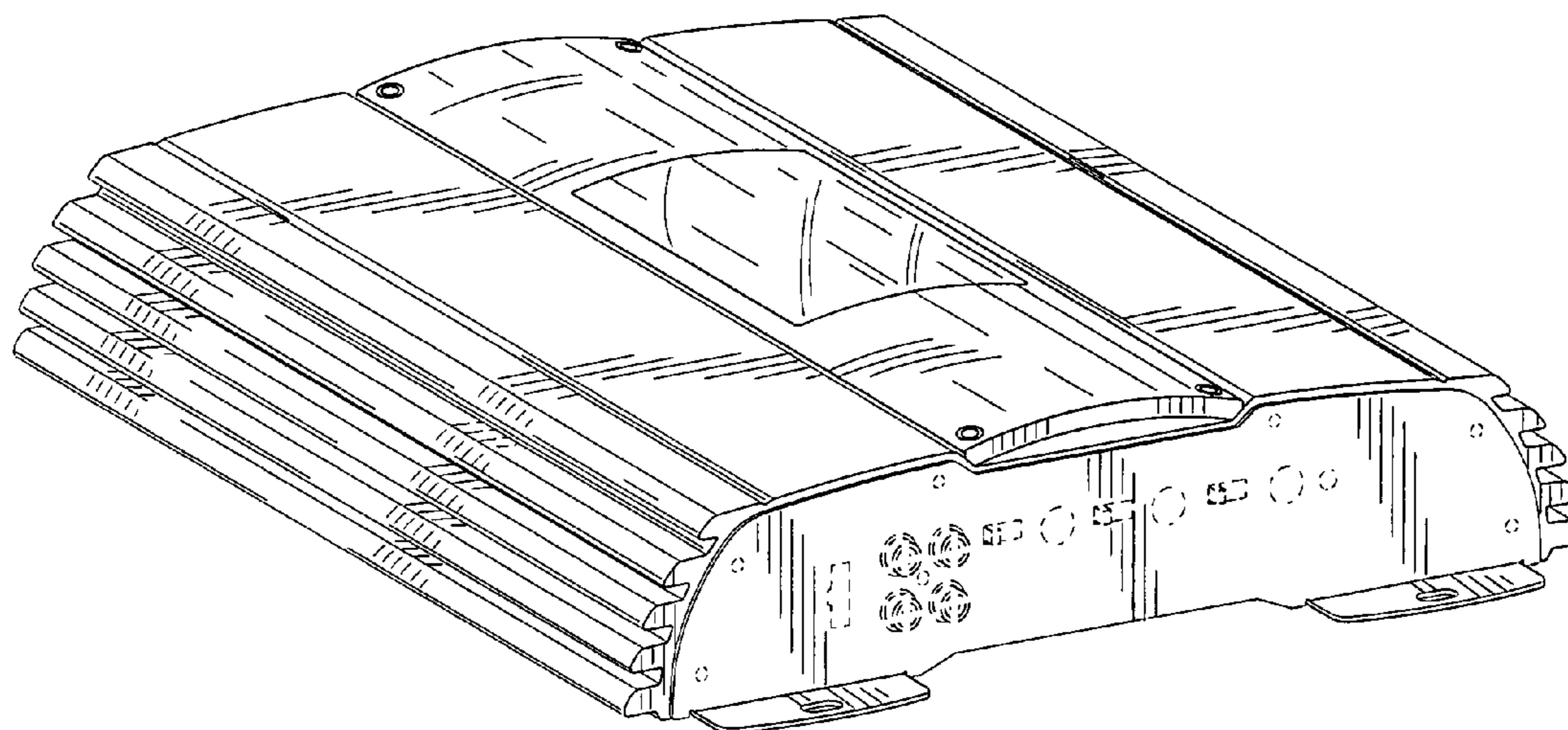

FIG.1

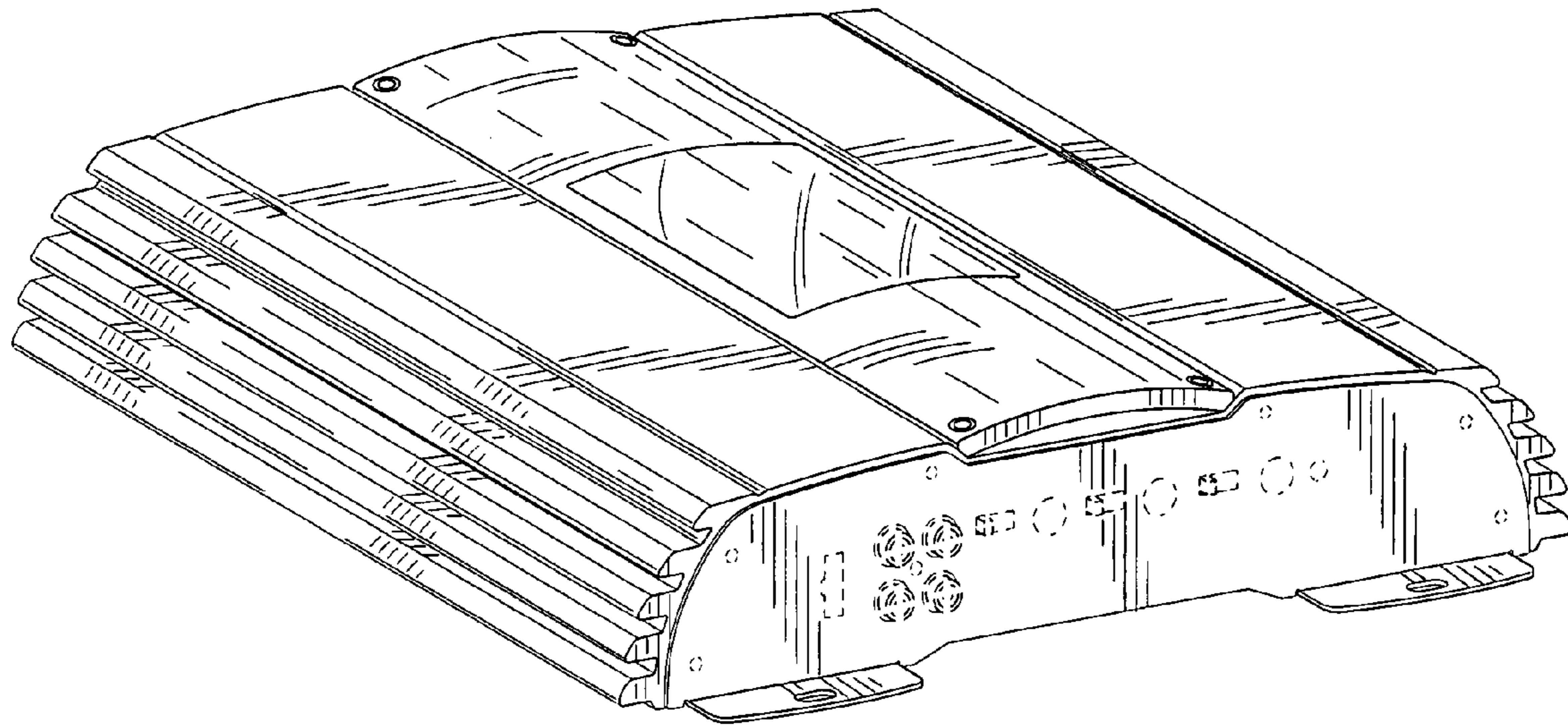

FIG.2

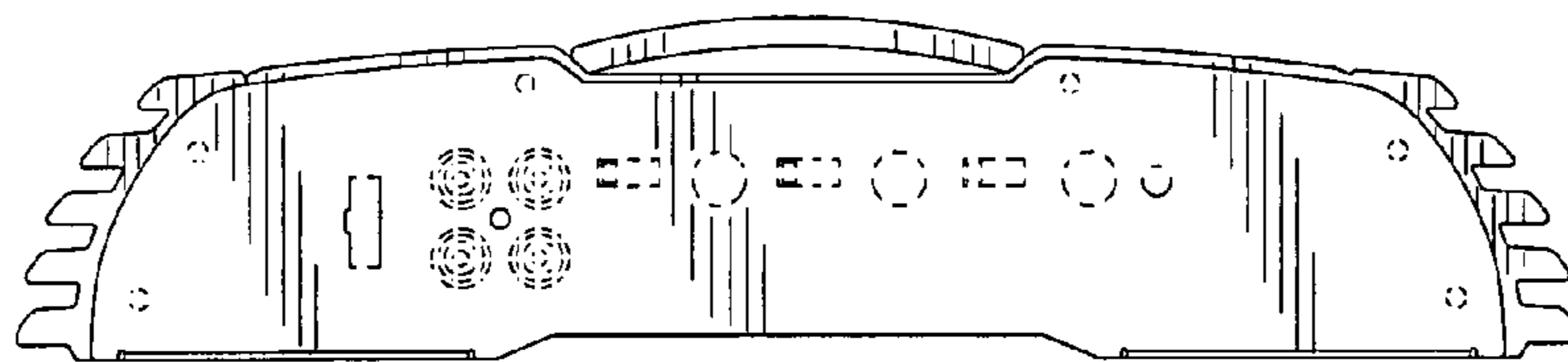

FIG.3

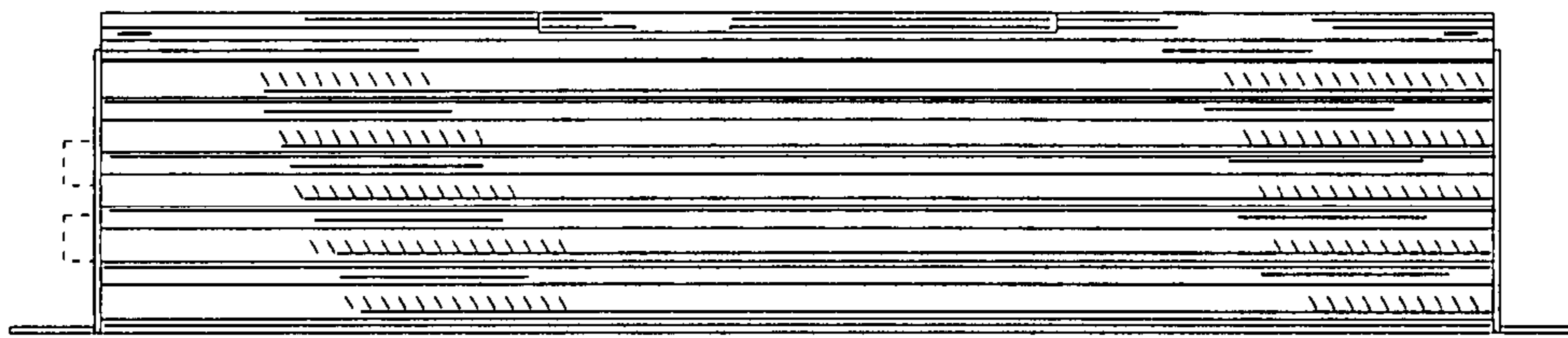

FIG.4

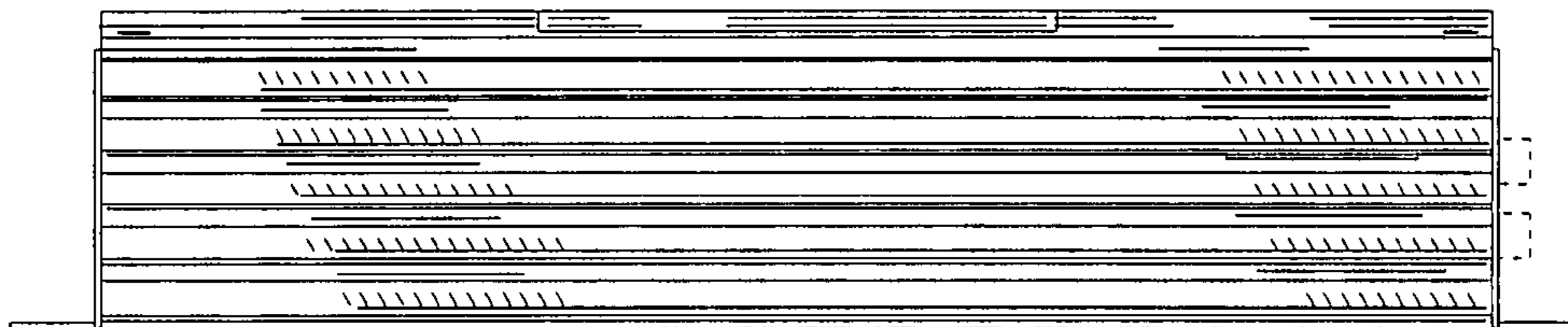

FIG.5

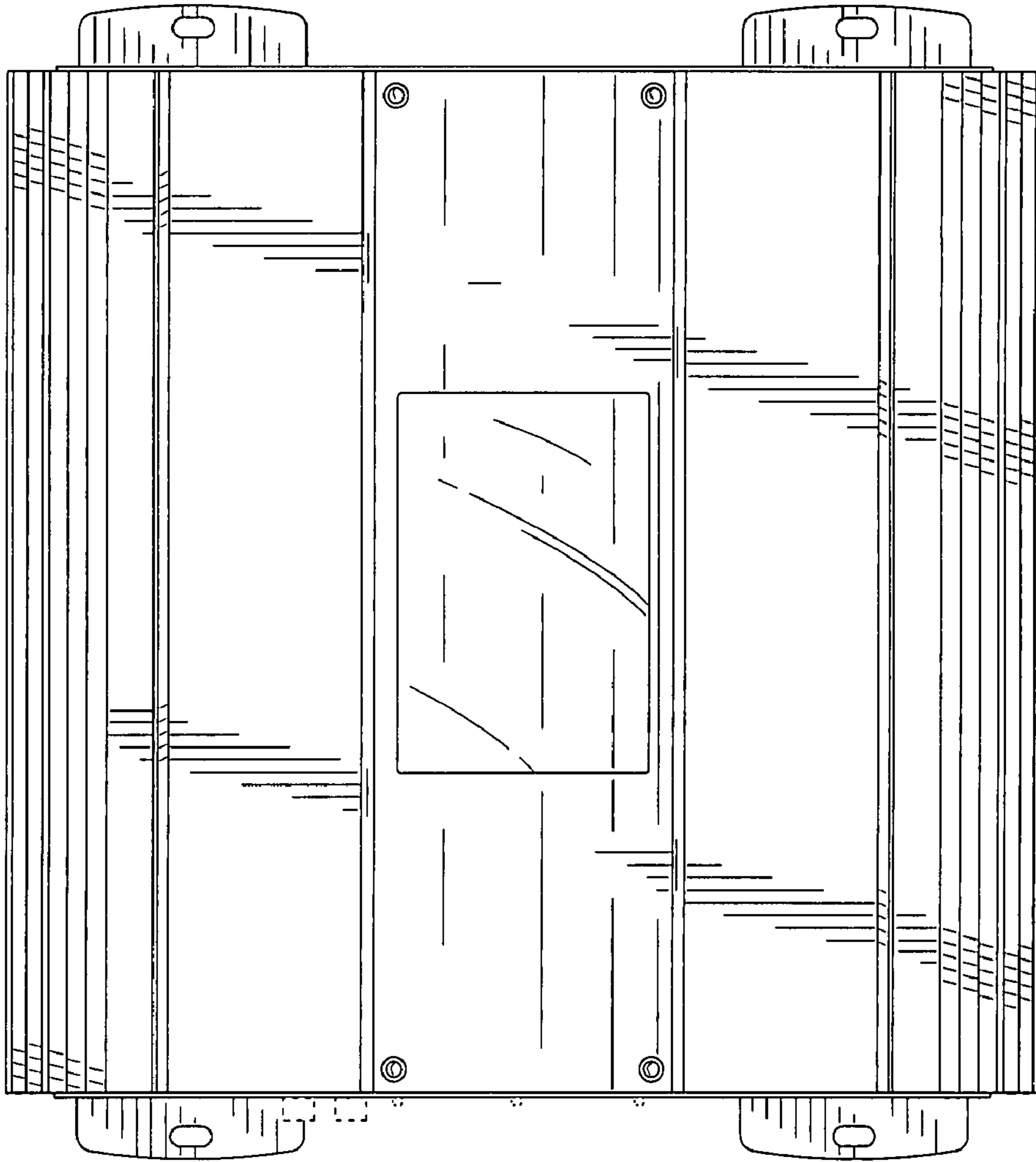

FIG.6

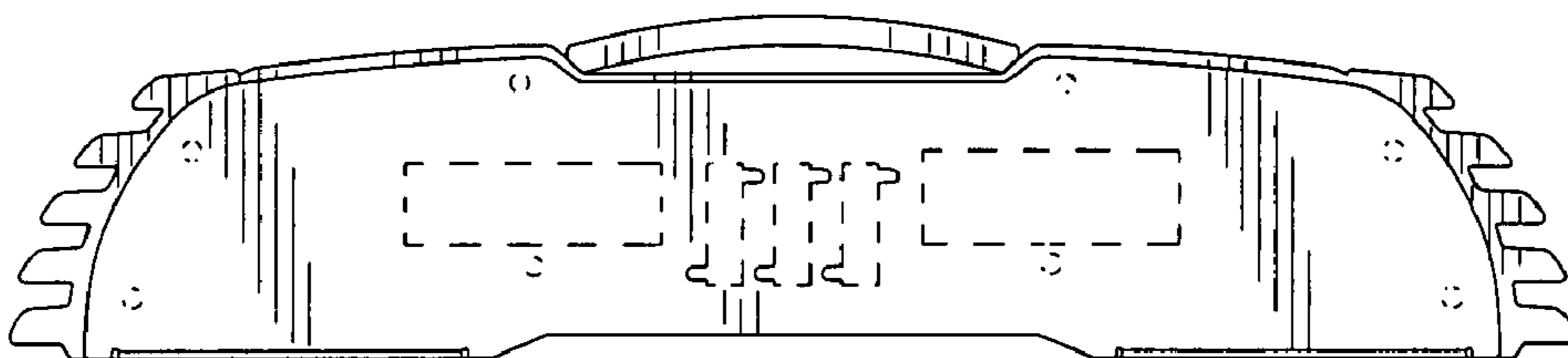

FIG.7

