

US00D548658S

(12) **United States Design Patent**
Kagawa et al.

(10) **Patent No.:** **US D548,658 S**

(45) **Date of Patent:** **** Aug. 14, 2007**

(54) **DRIP MOLD FOR AUTOMOBILES**

(57) **CLAIM**

(75) Inventors: **Mamoru Kagawa**, Wako (JP);
Hiroyuki Sase, Wako (JP); **Tetsuji Tamura**, Ibara (JP)

The ornamental design for a drip mold for automobiles, as shown and described.

(73) Assignees: **Honda Giken Kogyo Kabushiki Kaisha**, Tokyo (JP); **Katayama Kogyo Co., Ltd.**, Okayama (JP)

DESCRIPTION

(**) Term: **14 Years**

FIG. 1 is a front view of the drip mold;

(21) Appl. No.: **29/169,723**

FIG. 2 is a rear view of the drip mold;

(22) Filed: **Oct. 25, 2002**

FIG. 3 is a plan view of the drip mold;

(30) **Foreign Application Priority Data**

Apr. 26, 2002 (JP) 2002-11499

FIG. 4 is a bottom view of the drip mold;

(51) **LOC (8) Cl.** **12-08**

FIG. 5 is a right side view of the drip mold;

(52) **U.S. Cl.** **D12/190**

FIG. 6 is a left side view of the drip mold;

(58) **Field of Classification Search** D12/190,
D12/183, 400; D25/79; 293/126, 128, 132;
296/207, 106, 146.8, 151; 49/367-368, 476.1
See application file for complete search history.

FIG. 7 is an enlarged sectional end view taken along the line 7-7 in FIG. 1;

(56) **References Cited**

U.S. PATENT DOCUMENTS

- D148,831 S * 12/1948 Wagner D12/190
- D189,448 S * 12/1960 Loewy D12/190
- D222,744 S * 12/1971 Reilly D12/190
- D259,341 S * 5/1981 Wang D12/190
- D379,957 S * 6/1997 Streffling D12/183
- 6,113,177 A * 9/2000 Parkinson 296/151

FIG. 8 is an enlarged sectional end view taken along the line 8-8 in FIG. 1;

FIG. 9 is an enlarged sectional end view taken along the line 9-9 in FIG. 1;

FIG. 10 is an enlarged sectional end view taken along the line 10-10 in FIG. 1;

FIG. 11 is an enlarged sectional end view taken along the line 11-11 in FIG. 1;

FIG. 12 is an enlarged sectional end view taken along the line 12-12 in FIG. 1;

FIG. 13 is a perspective view of the drip mold showing the state of use on an automobile;

FIG. 14 is an enlarged sectional end view taken along the line 14-14 in FIG. 13;

FIG. 15 is an enlarged sectional end view taken along the line 15-15 in FIG. 13;

FIG. 16 is an enlarged sectional end view taken along the line 16-16 in FIG. 13;

* cited by examiner

Primary Examiner—Stacia Cadmus

(74) *Attorney, Agent, or Firm*—Arent Fox LLP

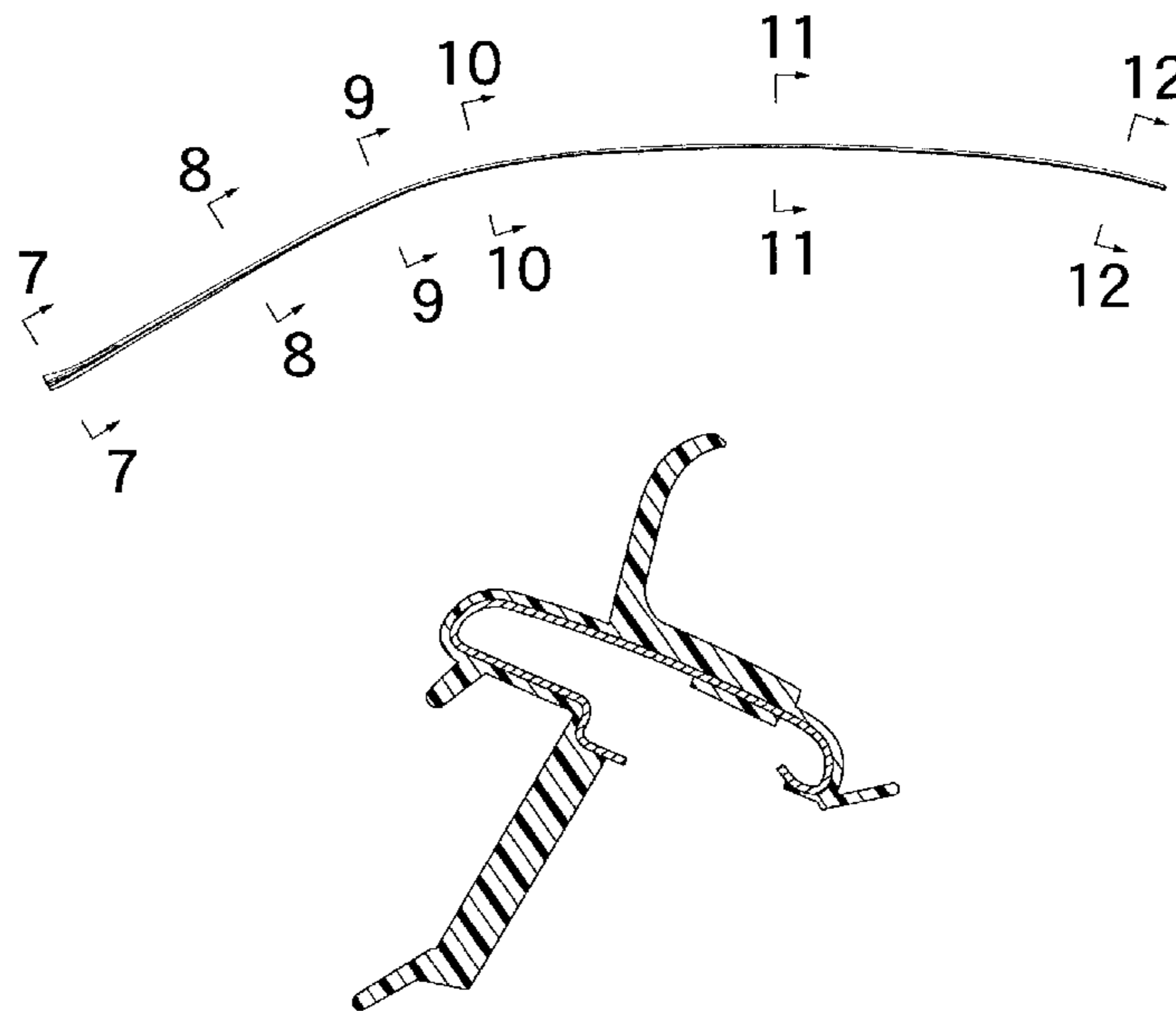

FIG. 17 is a front view of the drip mold;

FIG. 18 is an enlarged front view of a part 18-20 in FIG. 17;

FIG. 19 is an enlarged plan view of the part 18-20 in FIG. 17;

FIG. 20 is an enlarged left side view of the part 18-20 in FIG. 17;

FIG. 21 is an enlarged front view of a part 21-24 in FIG. 17;

FIG. 22 is an enlarged rear view of the part 21-24 in FIG. 17;

FIG. 23 is an enlarged plan view of the part 21-24 in FIG. 17;

FIG. 24 is an enlarged bottom view of the part 21-24 in FIG. 17;

FIG. 25 is an enlarged front view of a part 25-29 in FIG. 17;

FIG. 26 is an enlarged rear view of the part 25-29 in FIG. 17;

FIG. 27 is an enlarged plan view of the part 25-29 in FIG. 17;

FIG. 28 is an enlarged bottom view of the part 25-29 in FIG. 17; and,

FIG. 29 is an enlarged right side view of the part 25-29 in FIG. 17.

The broken line showing of environment is for illustrative purposes only and forms no part of the claimed design.

1 Claim, 10 Drawing Sheets

FIG.1

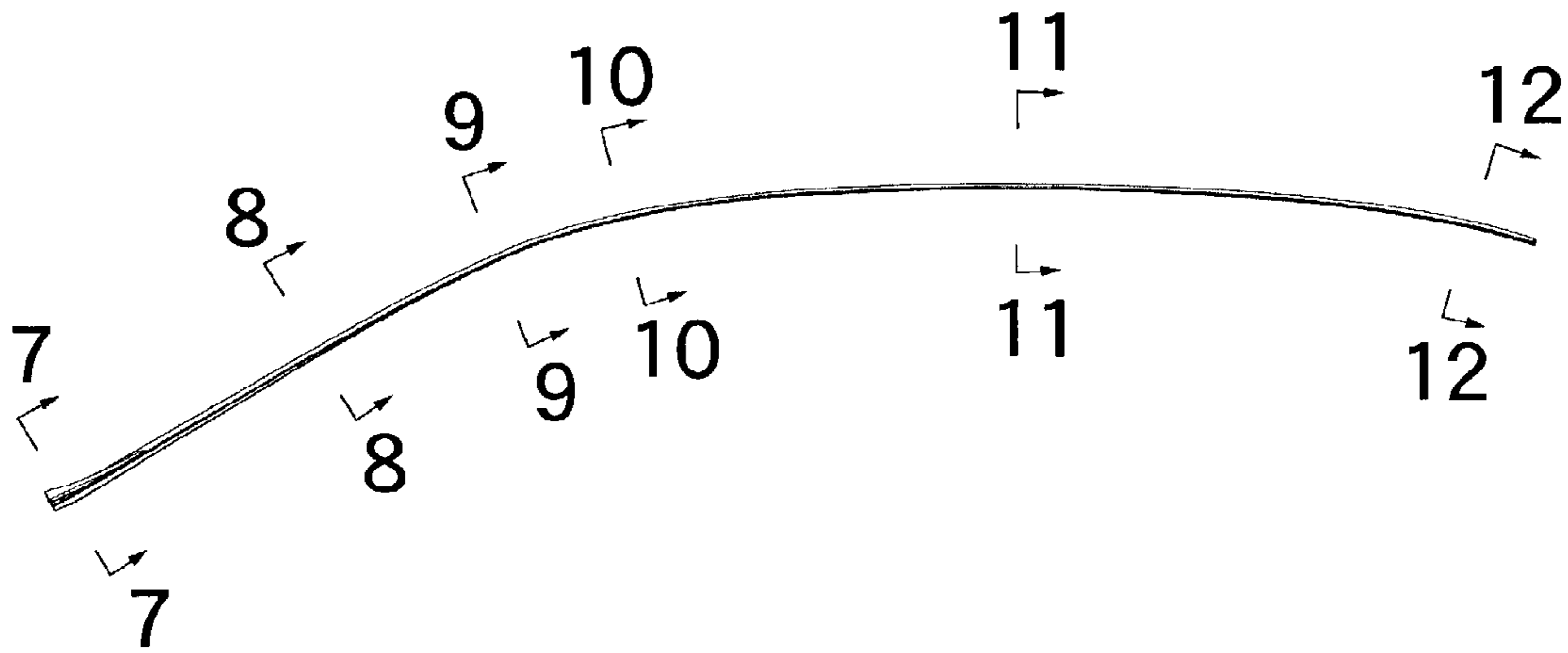

FIG.2



FIG.3

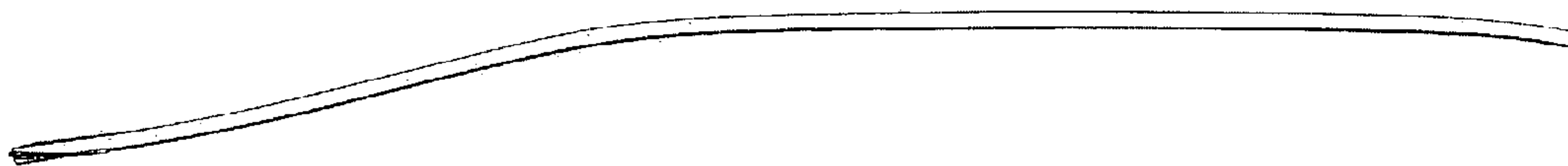

FIG.4



FIG.5

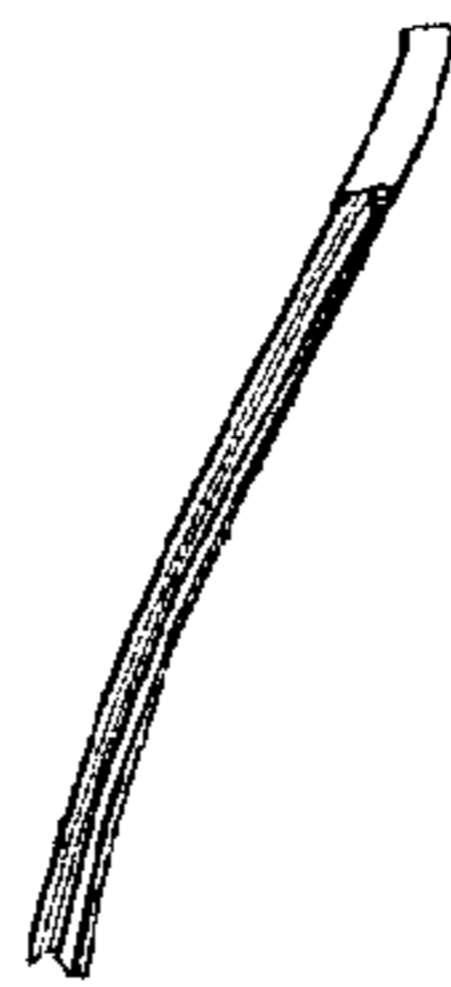

FIG.6

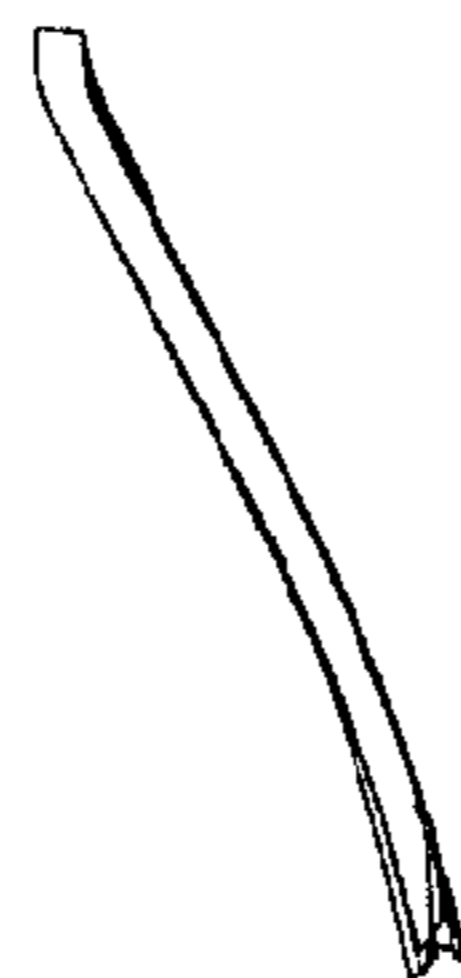

FIG.7

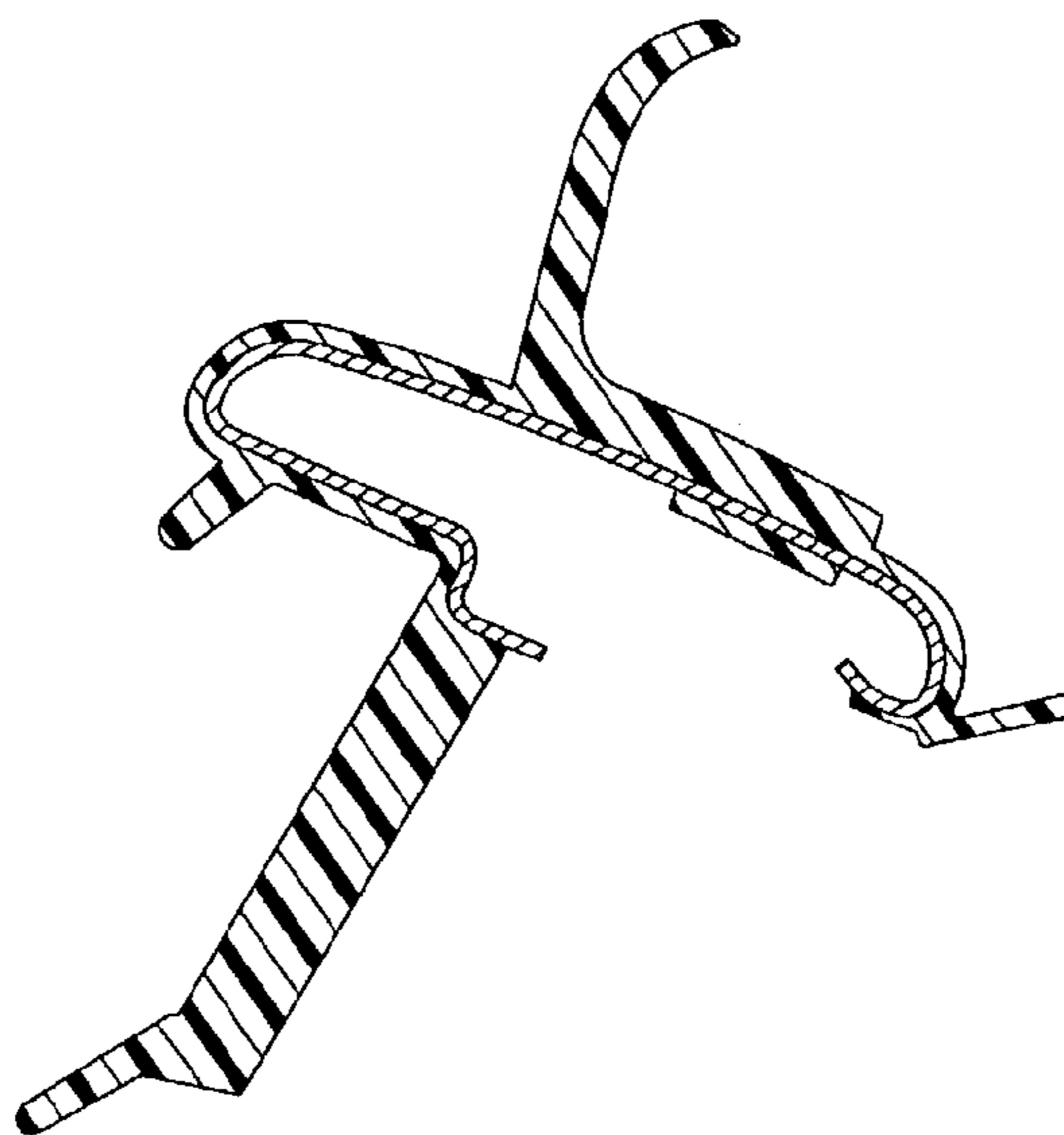

FIG.8

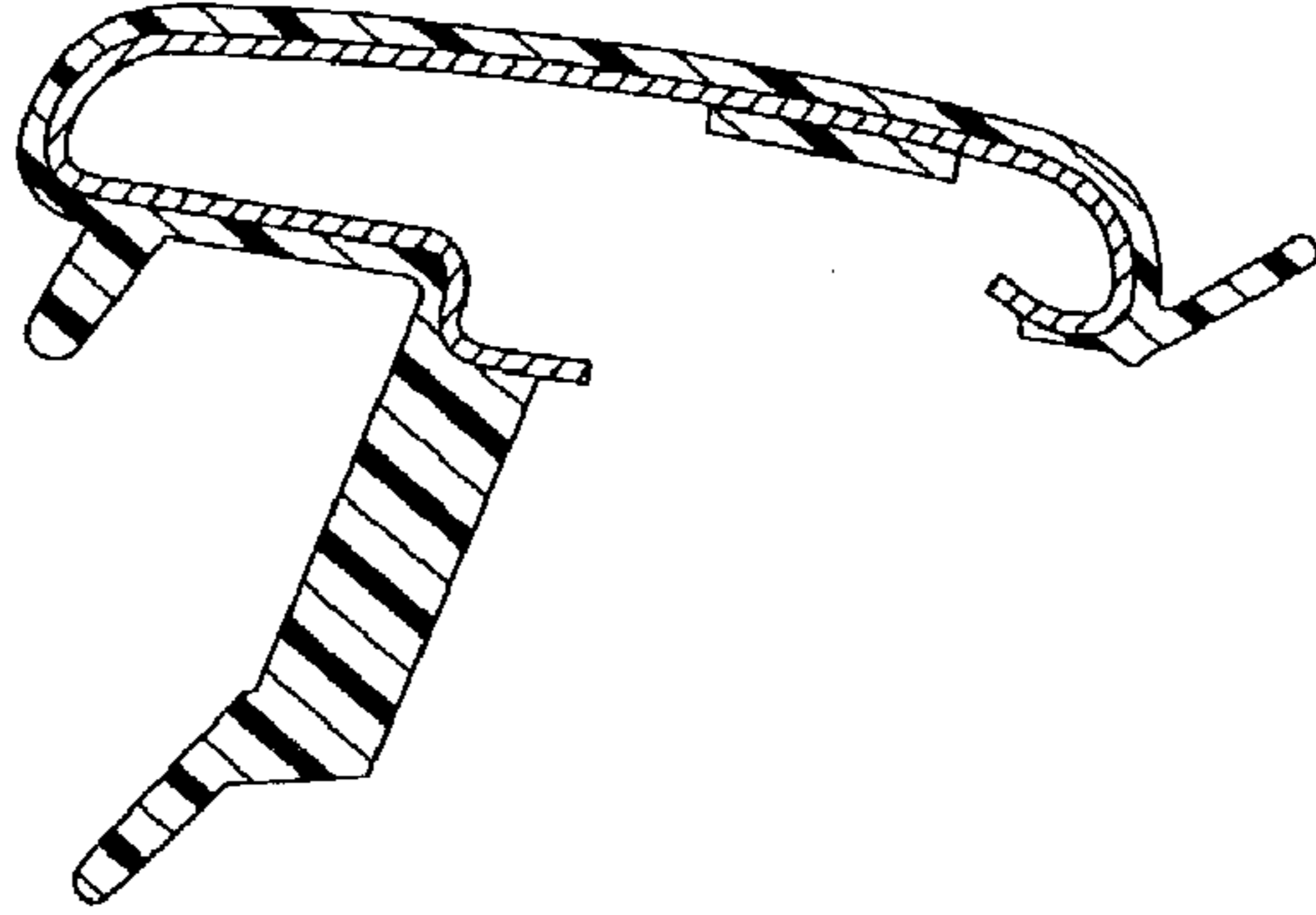

FIG.9

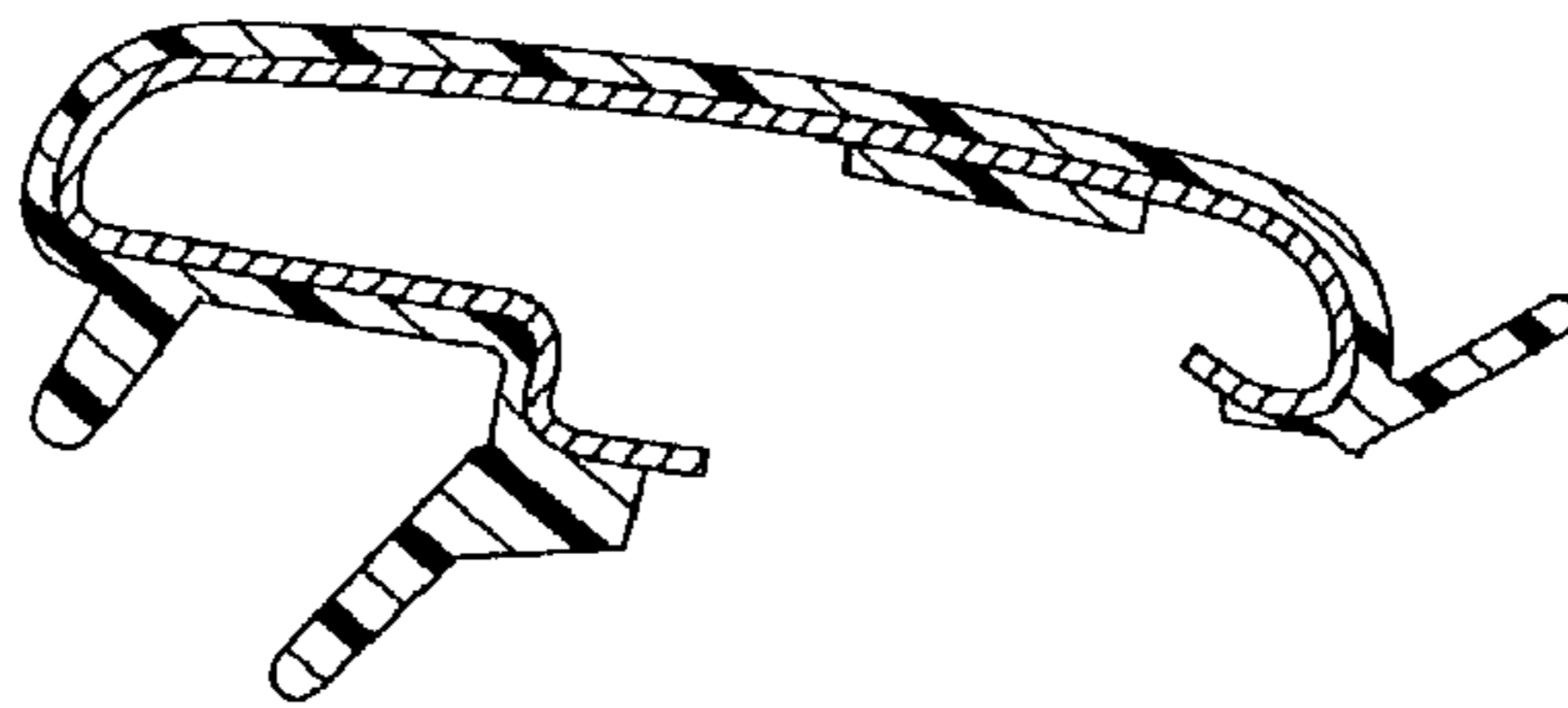

FIG.10

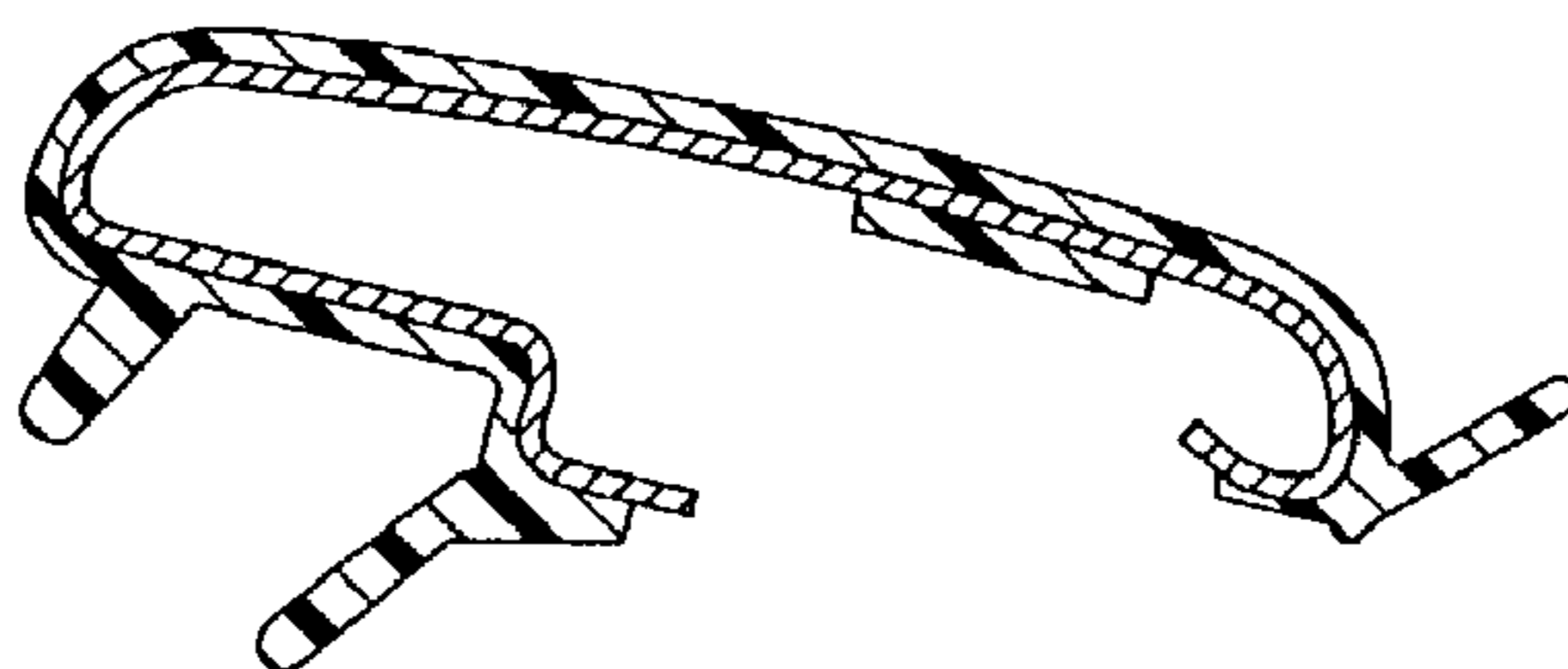

FIG.11

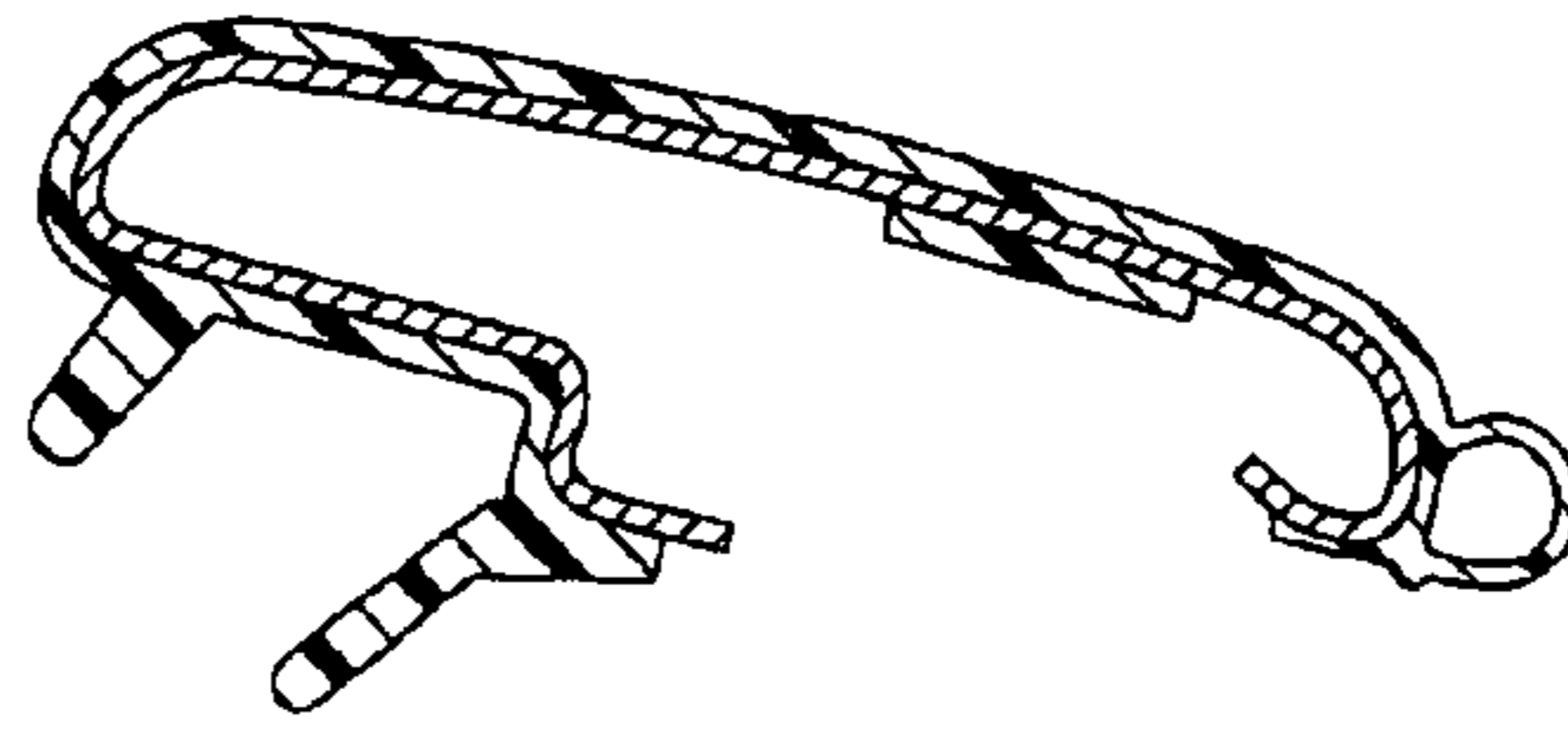

FIG.12

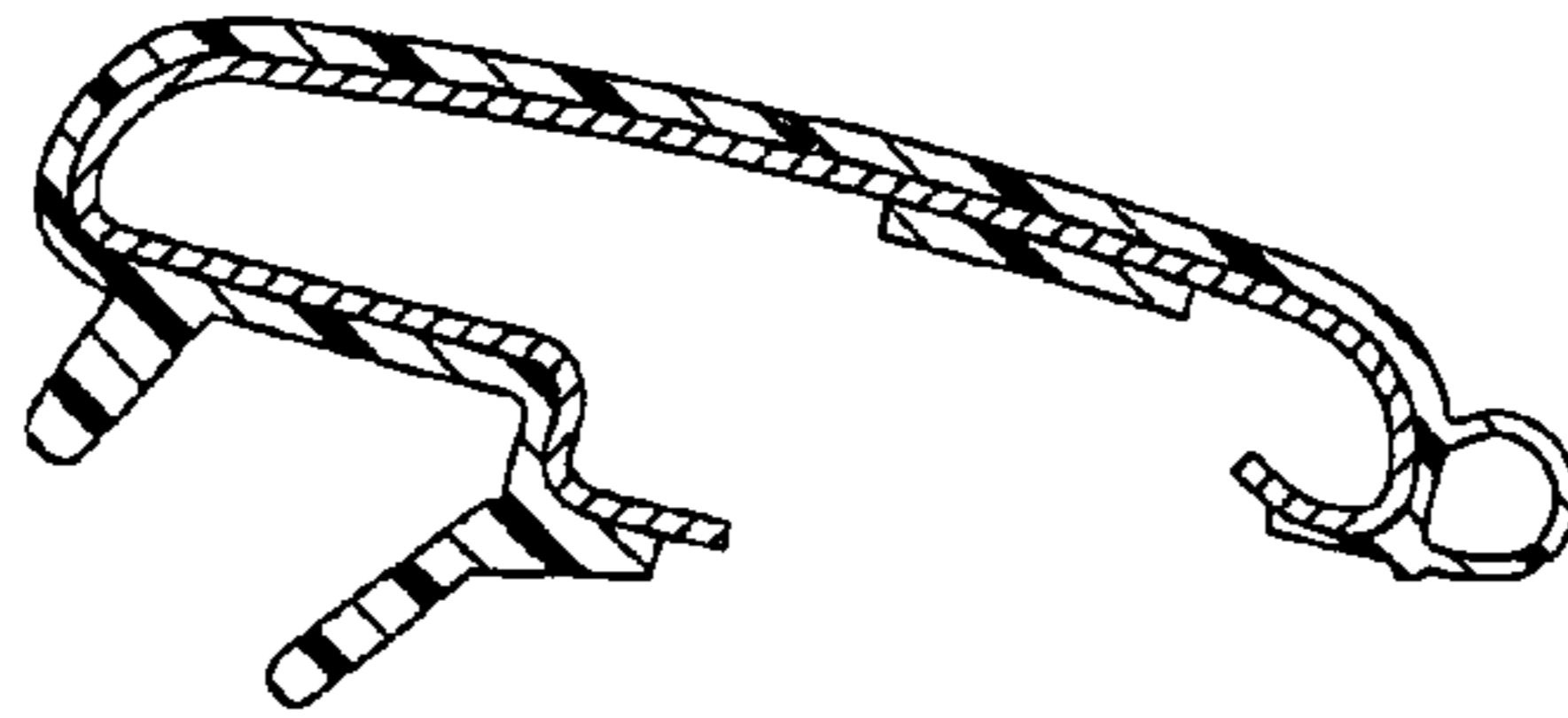

FIG.13

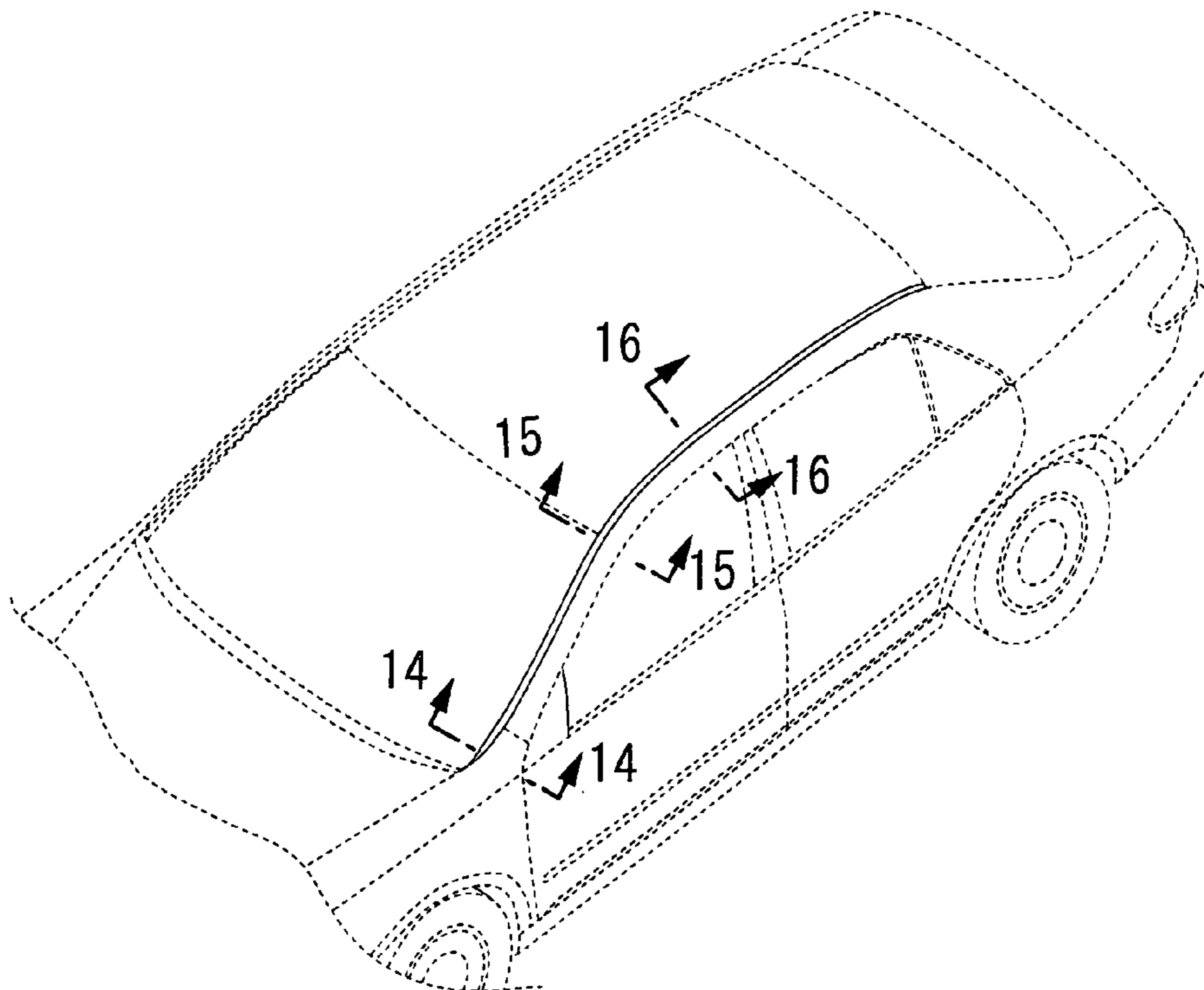

FIG.14

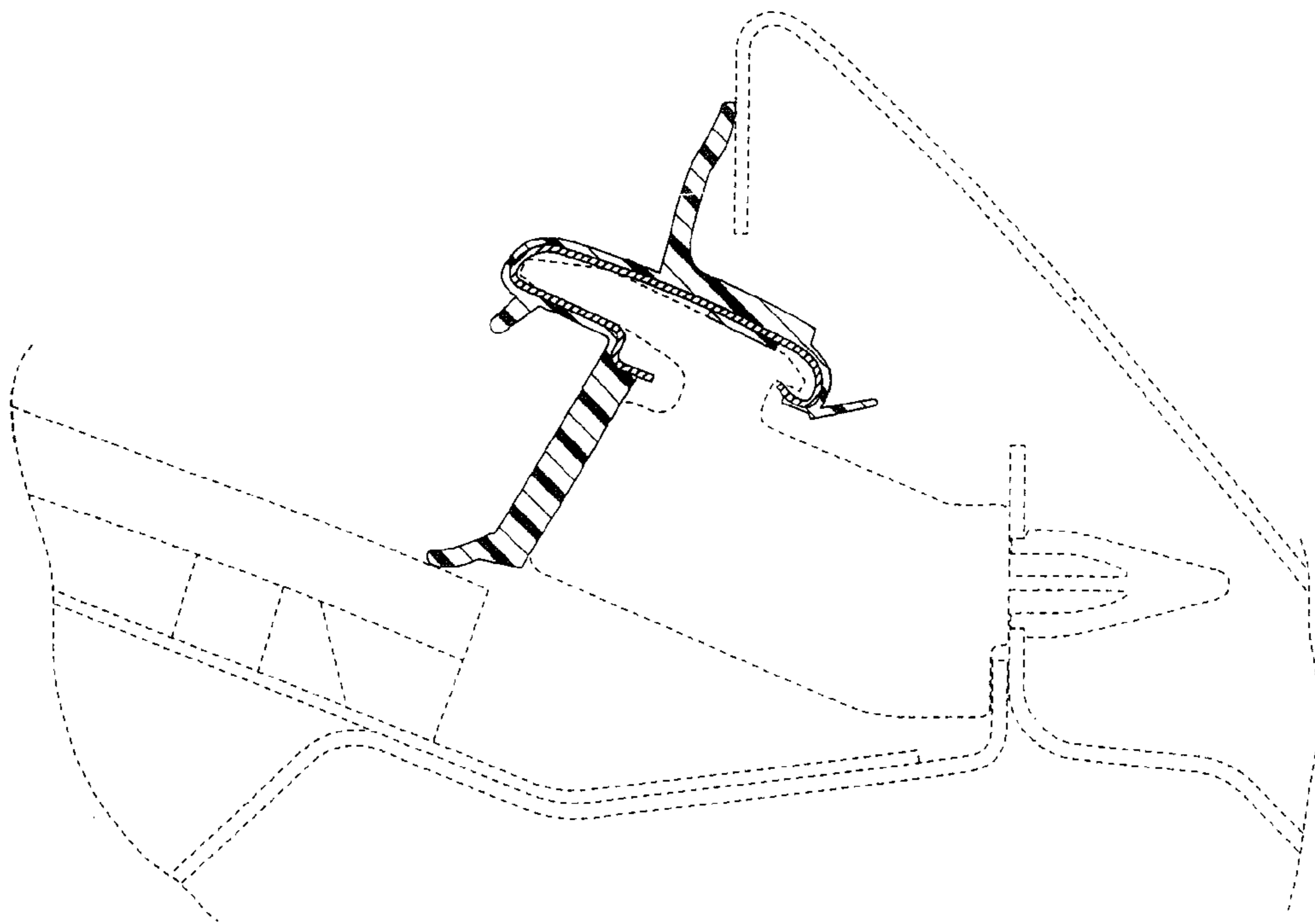

FIG.15

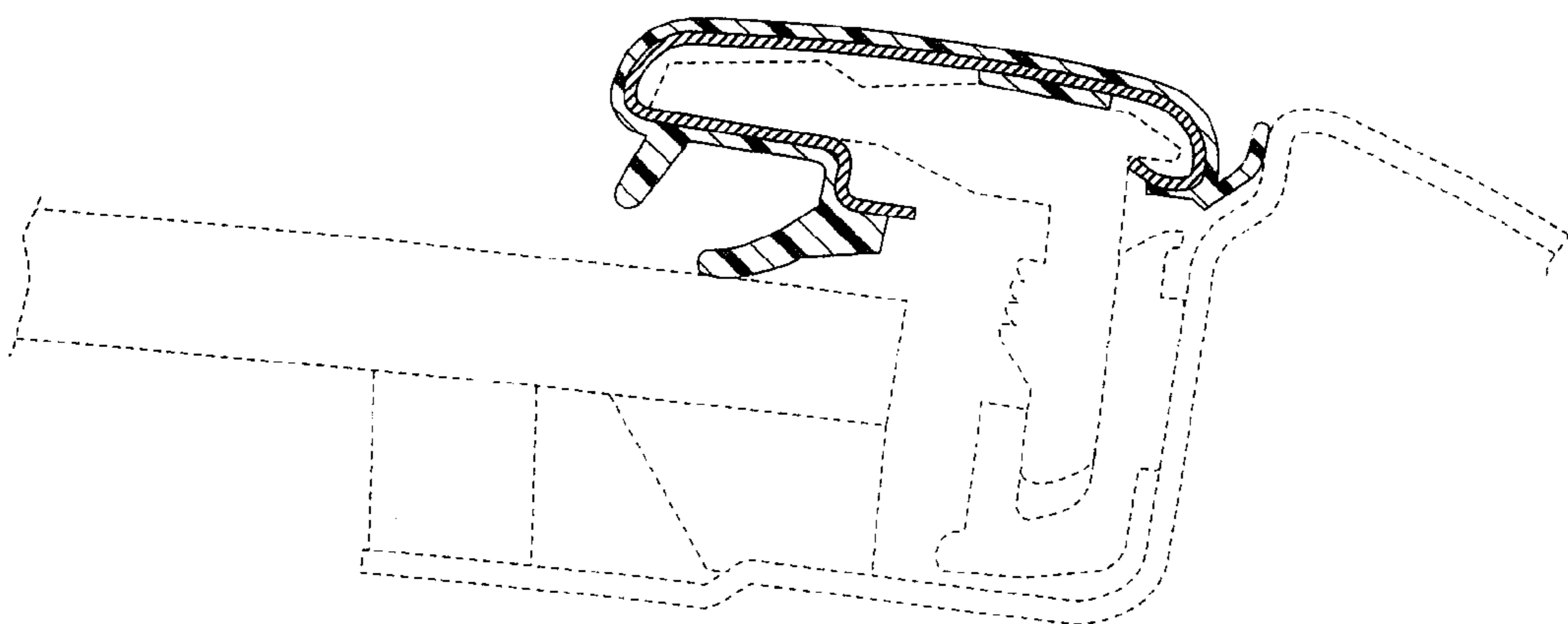

FIG.16

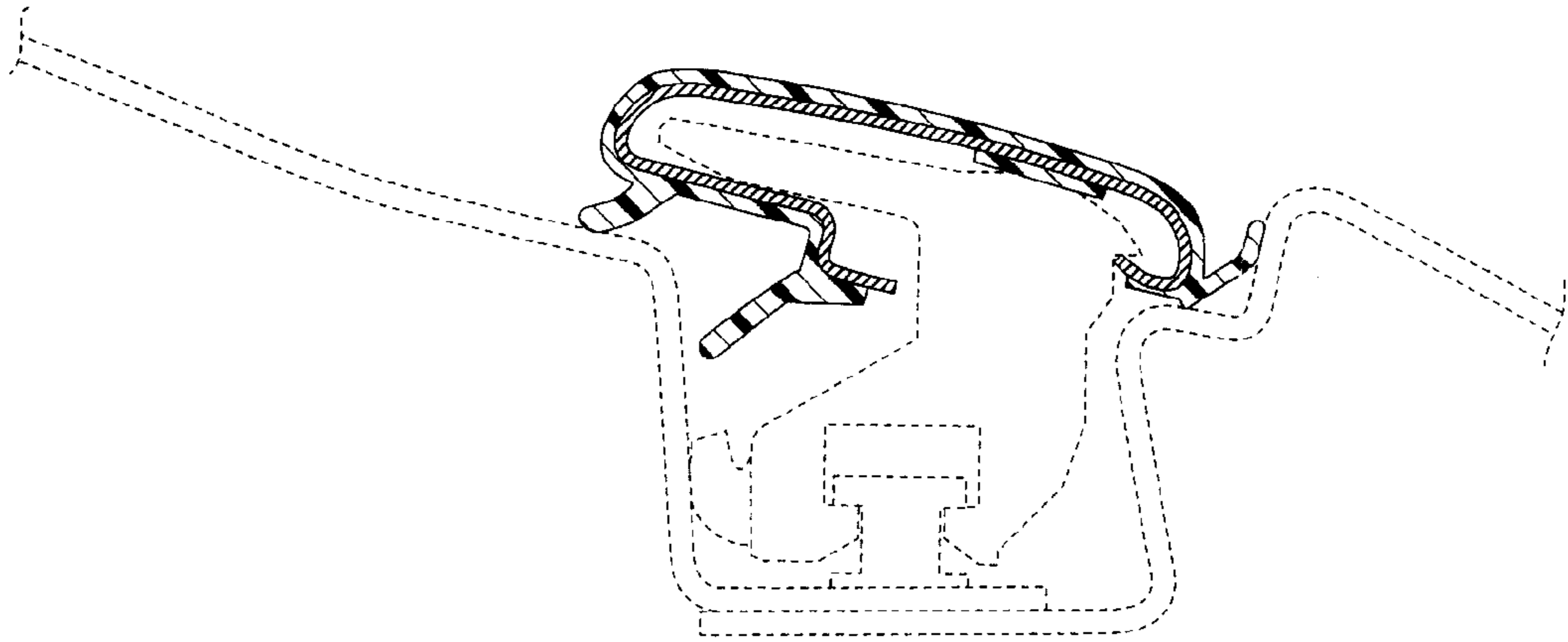

FIG.17

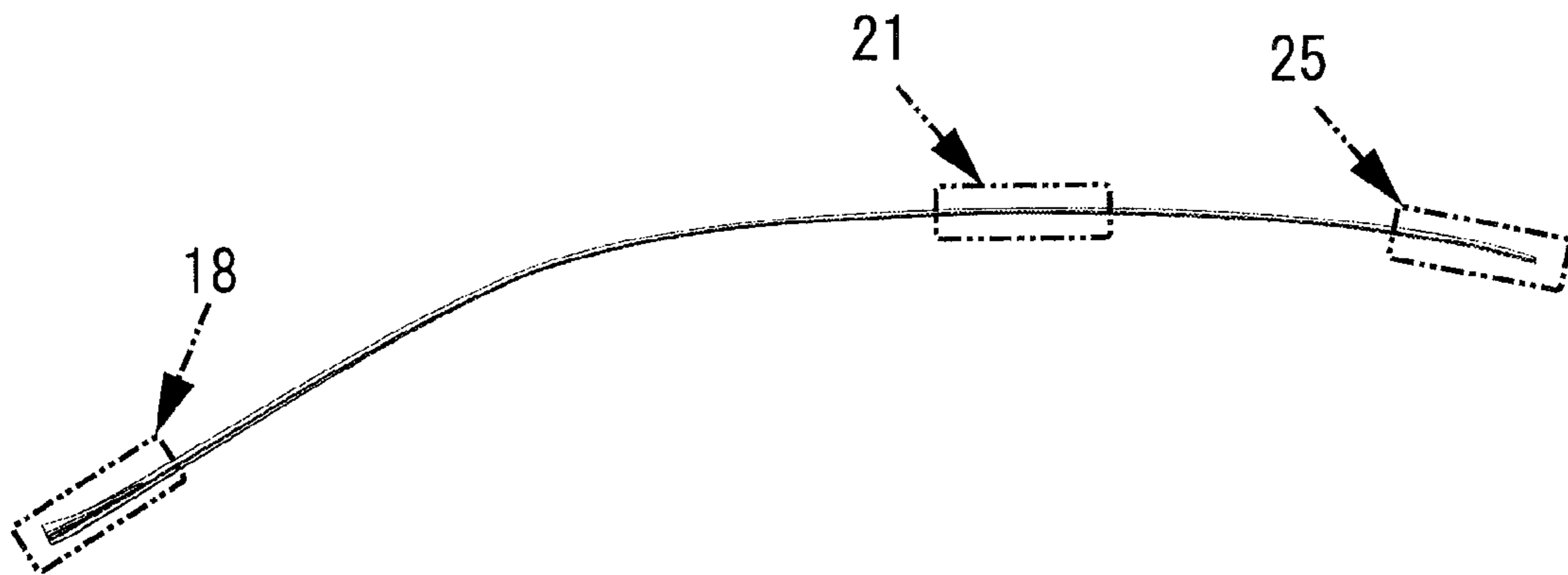

FIG.18

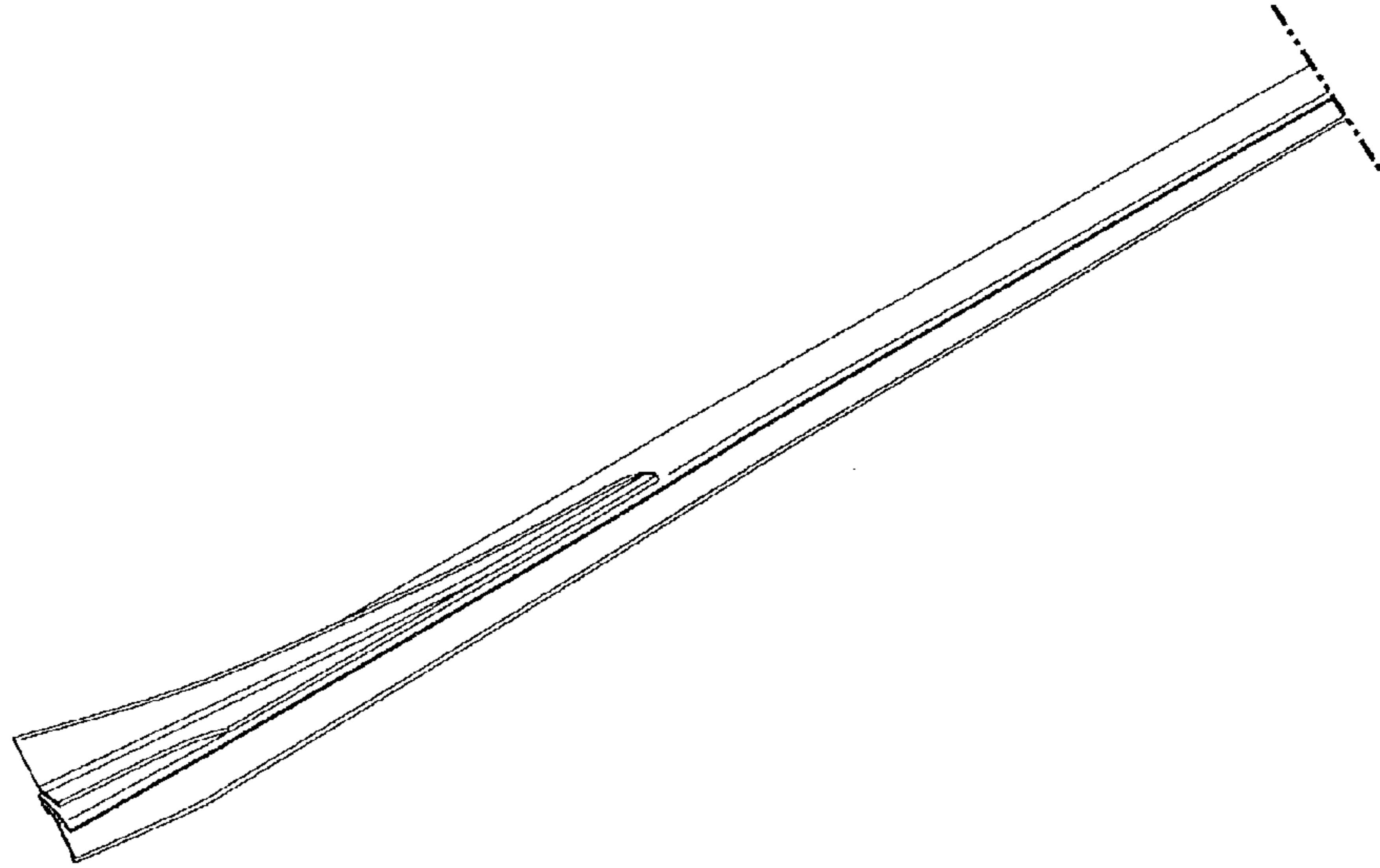

FIG.19

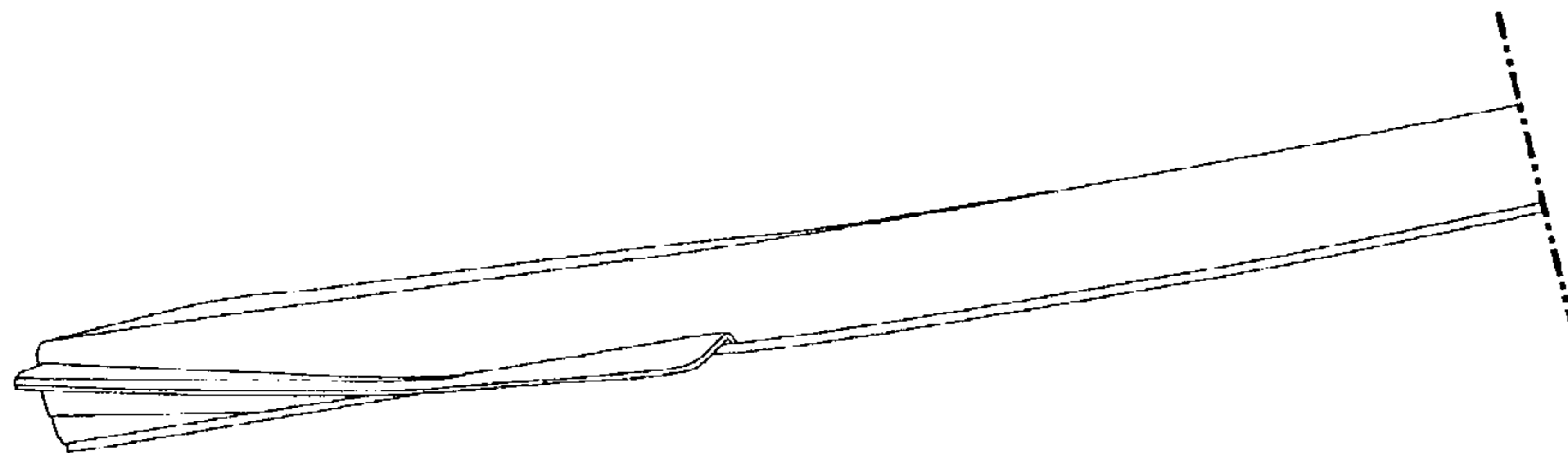

FIG.20

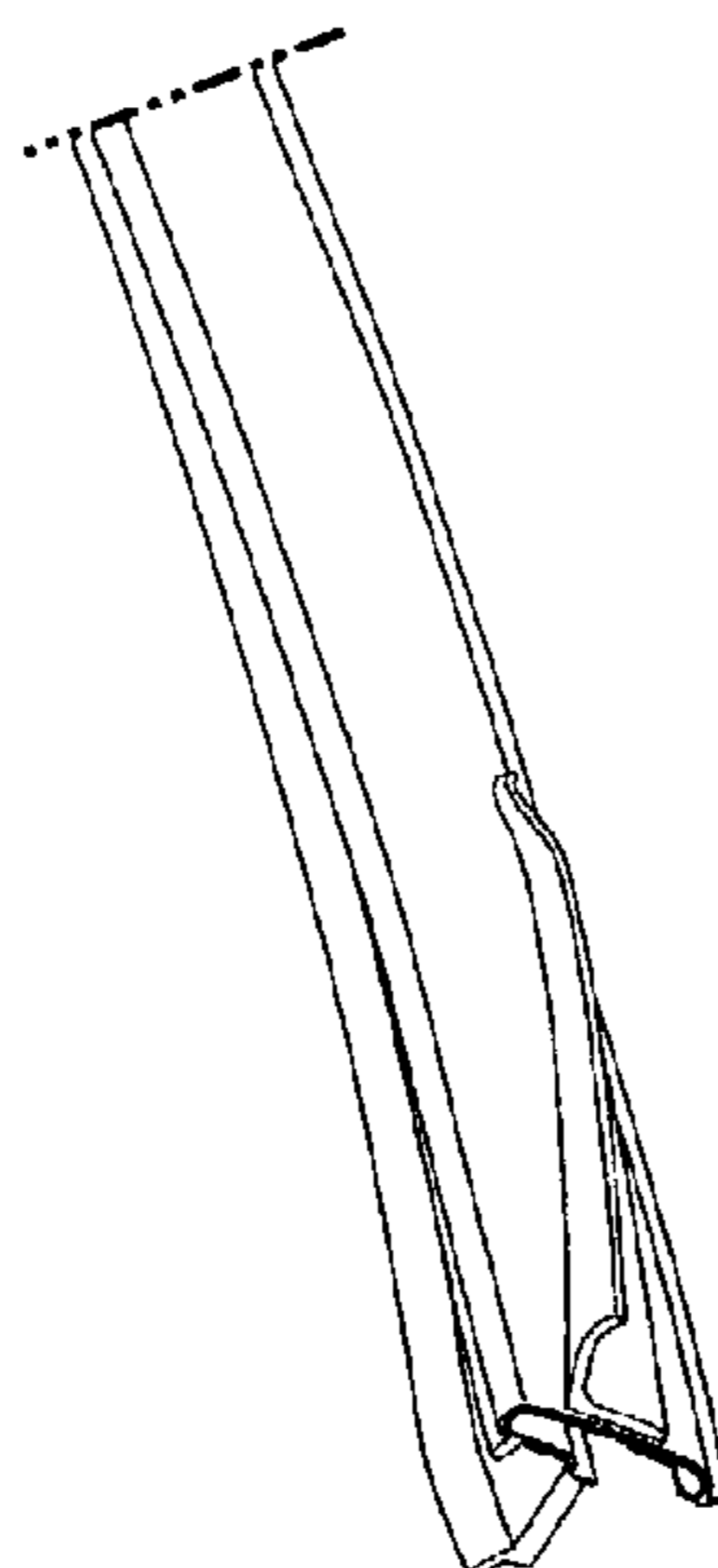

FIG.21

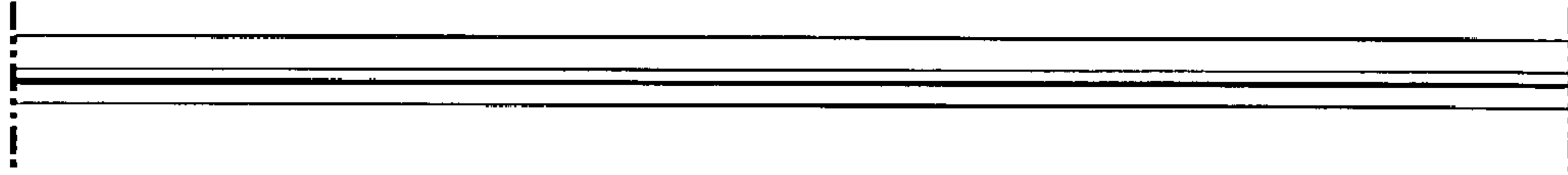

FIG.22

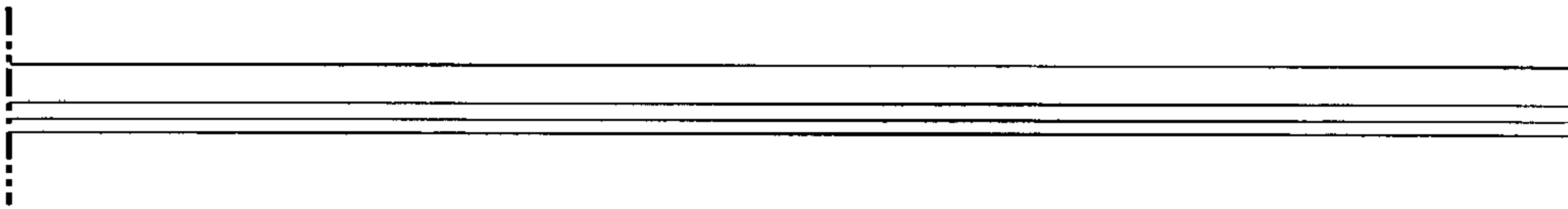

FIG.23

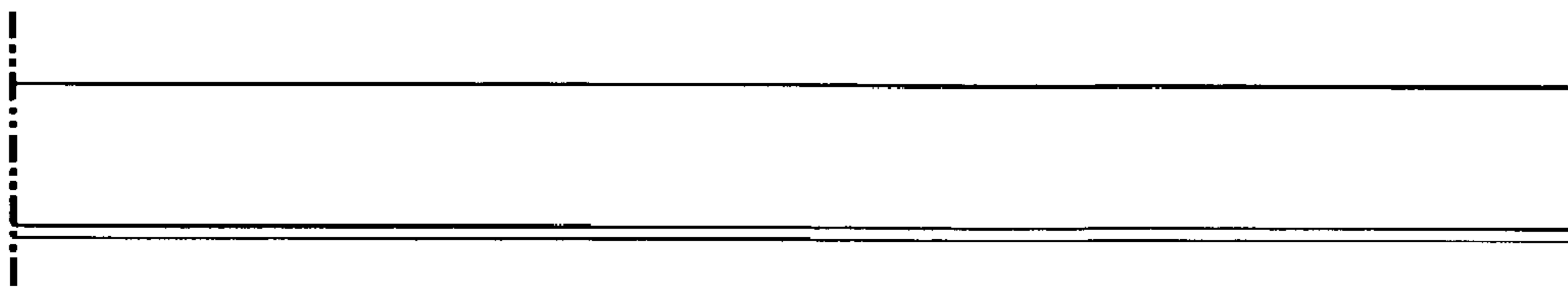

FIG.24

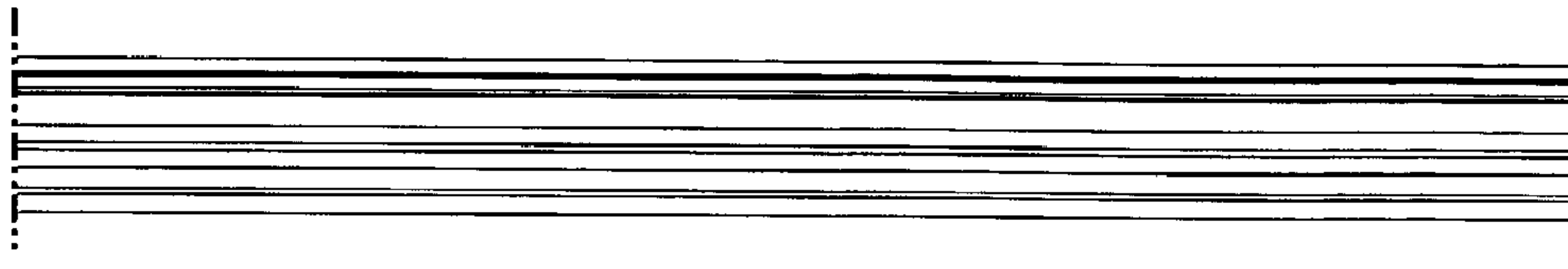

FIG.25

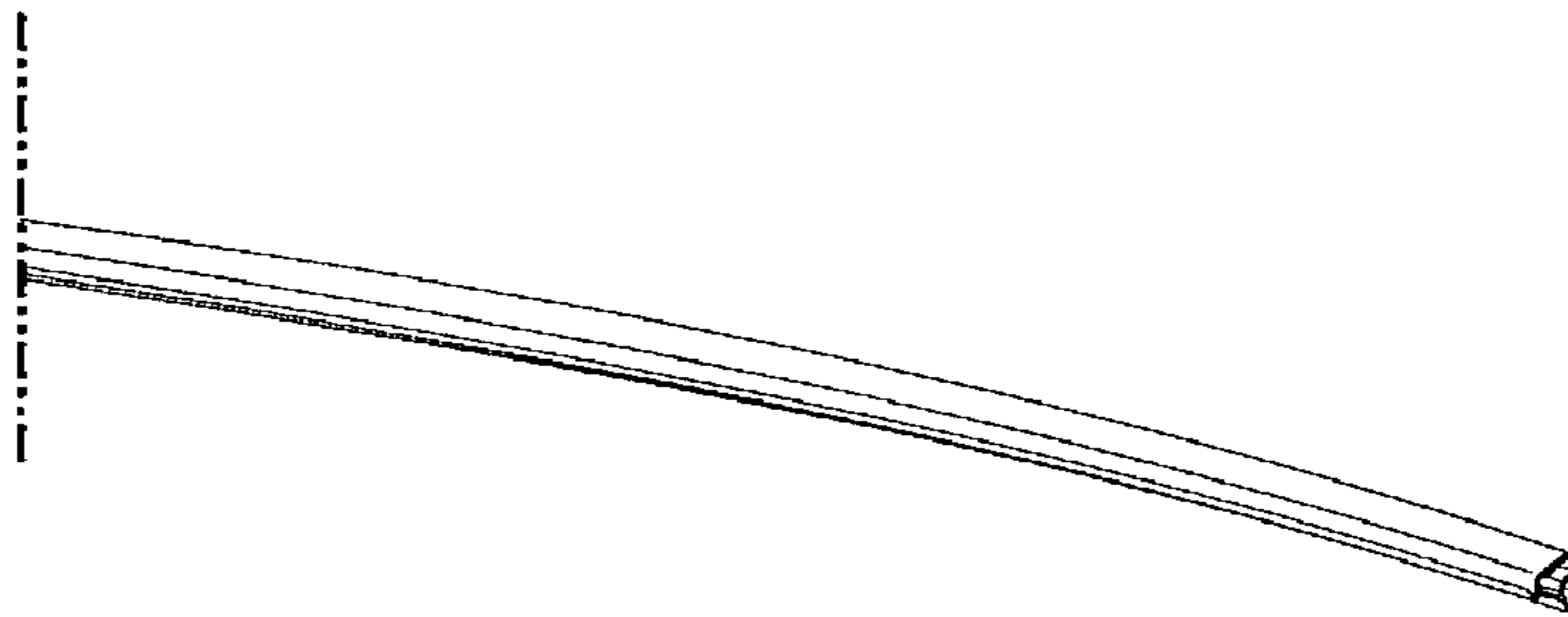

FIG.26

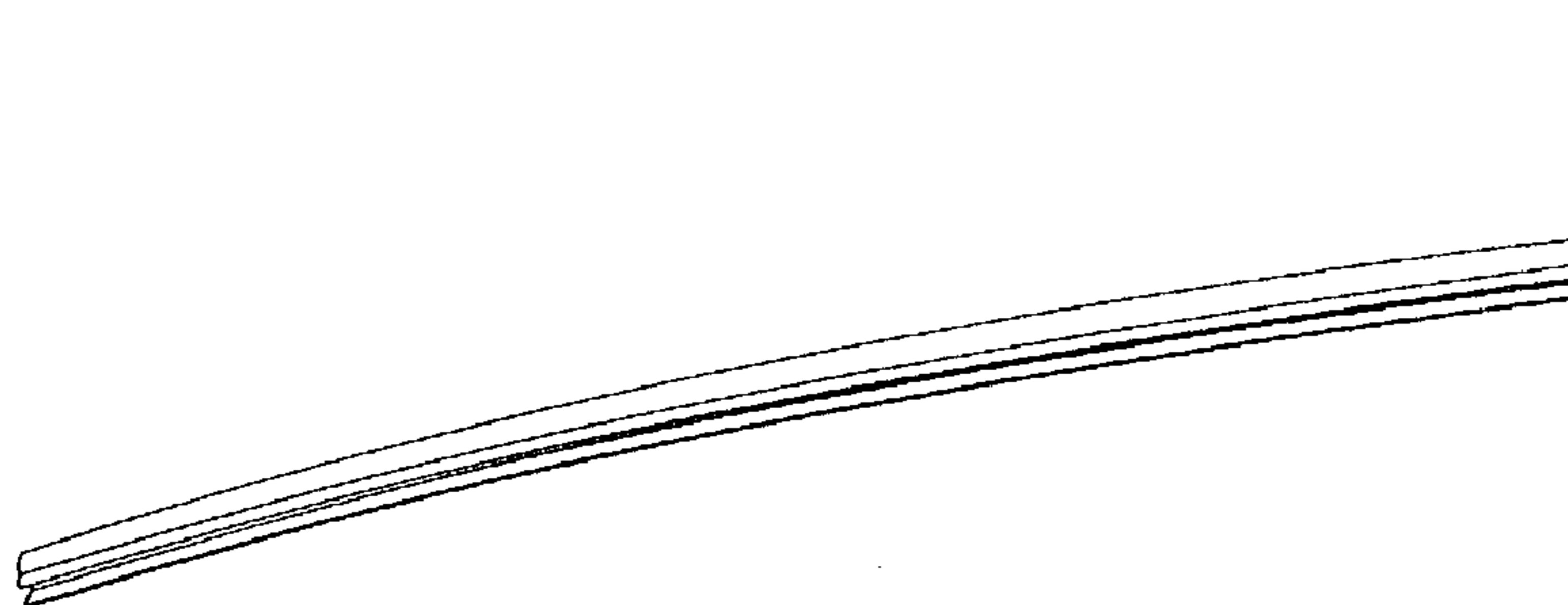

FIG.27

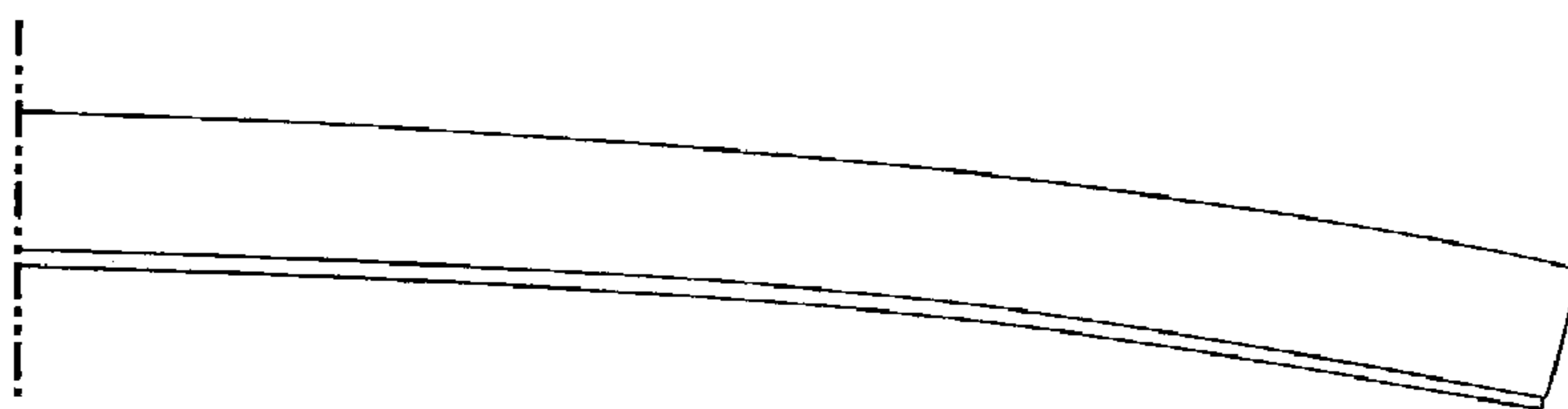

FIG.28



FIG.29

