



US00D548298S

(12) **United States Design Patent**  
**Miller**

(10) **Patent No.:** **US D548,298 S**

(45) **Date of Patent:** **\*\* Aug. 7, 2007**

(54) **GOLF CLUB GRIP UNDERLISTING**

(76) Inventor: **Lee Miller**, 1 Lower Ragsdale Dr.,  
Building 3, Suite 700, Monterey, CA  
(US) 93940

(\*\*) Term: **14 Years**

(21) Appl. No.: **29/257,344**

(22) Filed: **Apr. 3, 2006**

(51) **LOC (8) Cl.** ..... **21-02**

(52) **U.S. Cl.** ..... **D21/756**

(58) **Field of Classification Search** ..... D21/724,  
D21/729-732, 756, 757, 759, 789; 473/300-303,  
473/549-551; 273/301, 203

See application file for complete search history.

(56) **References Cited**

**U.S. PATENT DOCUMENTS**

2,221,421	A *	11/1940	Curry	.....	473/300
2,437,404	A *	3/1948	Robinson	.....	473/203
3,706,453	A *	12/1972	Rosasco, Jr.	.....	473/203
5,064,203	A *	11/1991	Hattori	.....	473/551
D330,060	S *	10/1992	Fagen	.....	D21/756
5,671,923	A *	9/1997	Huang	.....	273/301
5,797,813	A *	8/1998	Huang	.....	473/549
5,813,921	A *	9/1998	Huang	.....	473/300
5,827,129	A *	10/1998	Huang	.....	473/301
5,857,929	A *	1/1999	Huang	.....	473/549
5,890,972	A *	4/1999	Huang	.....	473/302
D449,866	S	10/2001	Miller	.....	D21/747
6,361,450	B1 *	3/2002	Huang	.....	473/300

6,656,057	B2 *	12/2003	Manual et al.	.....	473/300
6,666,777	B1 *	12/2003	Lamkin et al.	.....	473/300
6,695,713	B2 *	2/2004	Huang	.....	473/301
6,733,401	B1 *	5/2004	Huang	.....	473/301
6,843,732	B1 *	1/2005	Huang	.....	473/300
6,857,971	B2 *	2/2005	Huang	.....	473/300
D504,927	S	5/2005	Miller	.....	D21/756
D504,928	S	5/2005	Miller	.....	D21/756
2005/0187030	A1	8/2005	Miller	.....	473/300

\* cited by examiner

*Primary Examiner*—Mitchell Siegel

(74) *Attorney, Agent, or Firm*—Law Offices of J.D. Geraigery, P.C.; Janine D. Geraigery

(57) **CLAIM**

The ornamental design for a golf club grip underlisting, as shown and described.

**DESCRIPTION**

FIG. 1 is a perspective view of the golf club grip underlisting having a triangular rib with no exterior wrapping shown.

FIG. 2 is a front elevational view thereof.

FIG. 3 is a rear elevational view thereof.

FIG. 4 is a top plan view thereof.

FIG. 5 is a bottom plan view thereof.

FIG. 6 is a right side elevational view thereof; and,

FIG. 7 is a left side elevational view thereof.

**1 Claim, 4 Drawing Sheets**

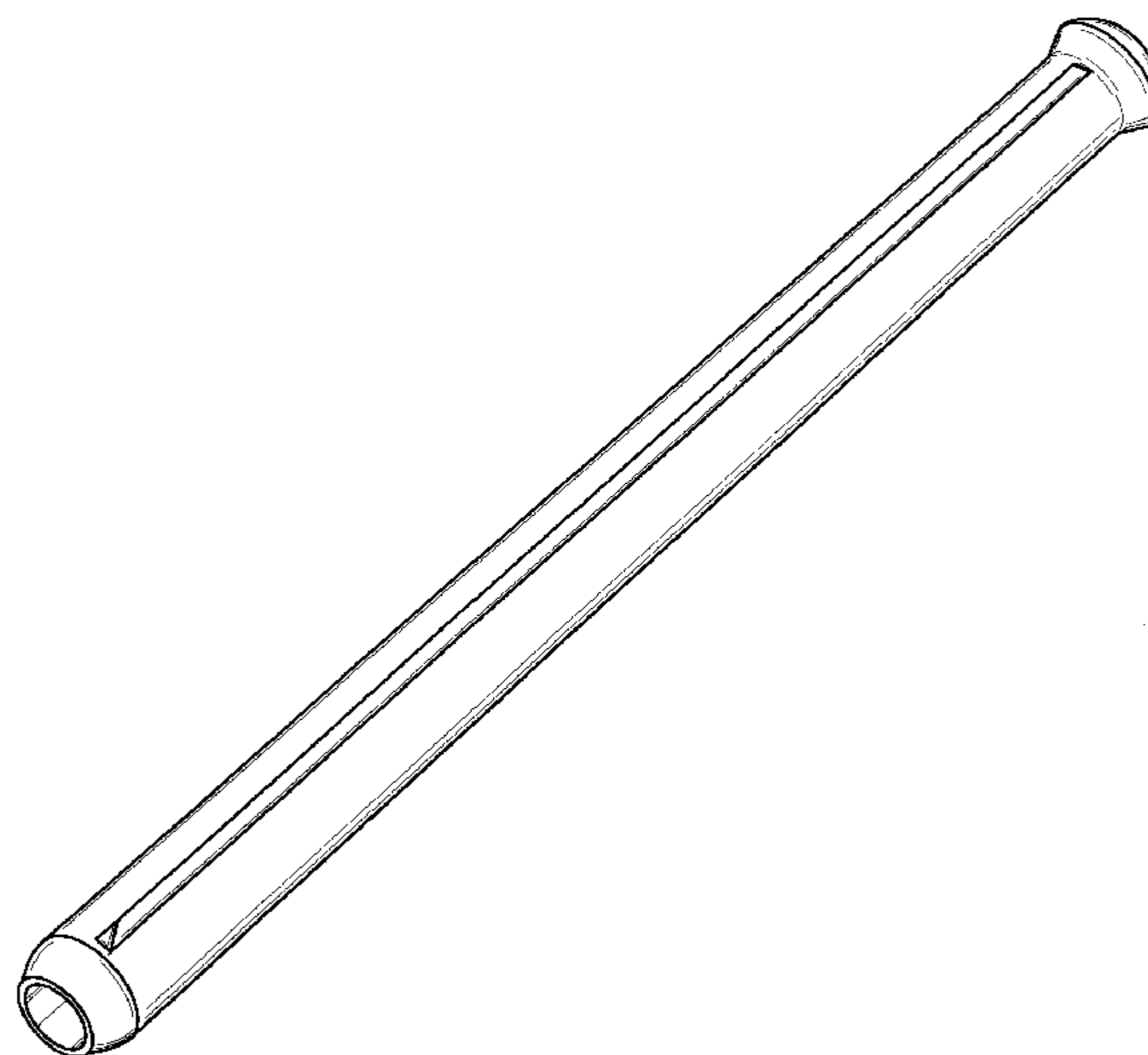

**ISOMETRIC**

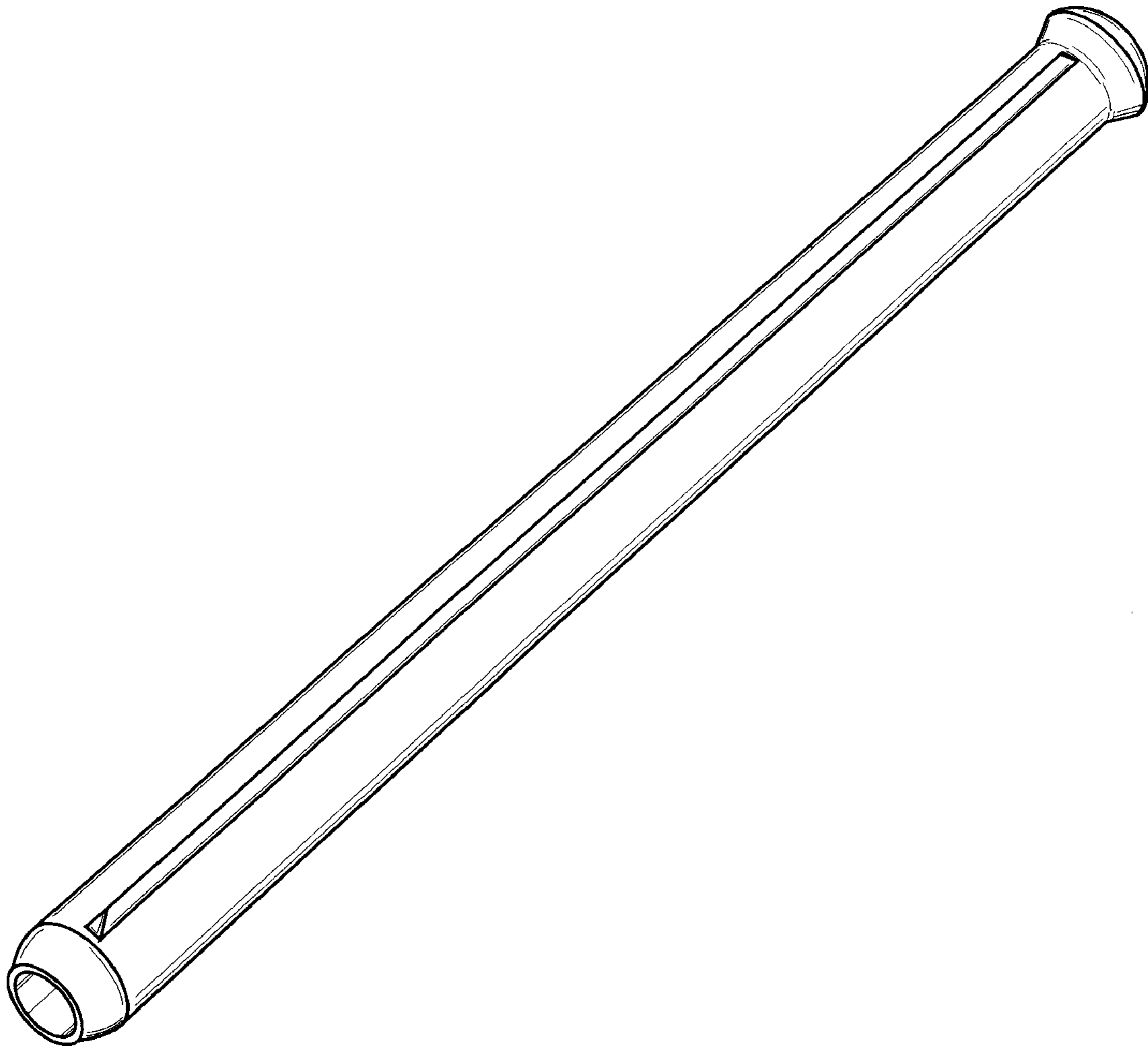

ISOMETRIC  
FIG. 1

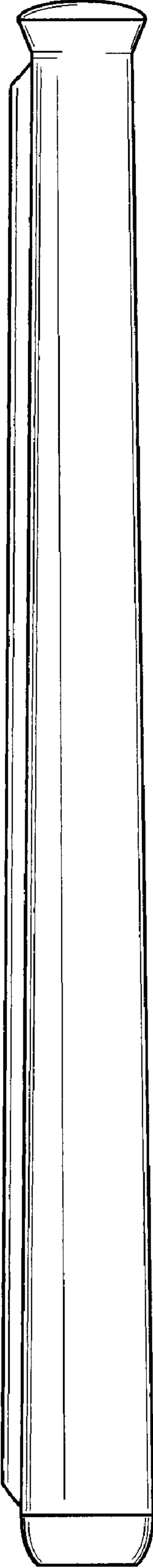

**FRONT**  
**FIG. 2**

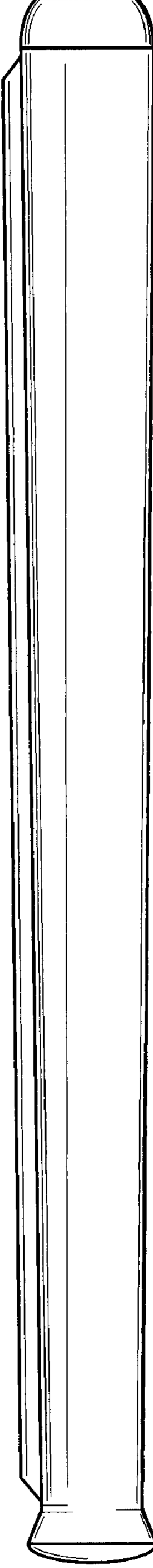

**BACK**  
**FIG. 3**

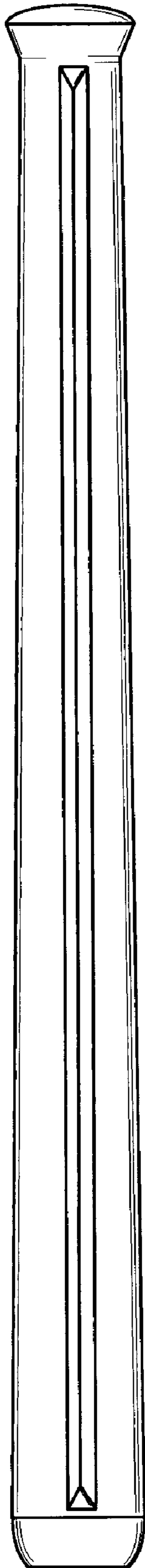

TOP  
FIG. 4

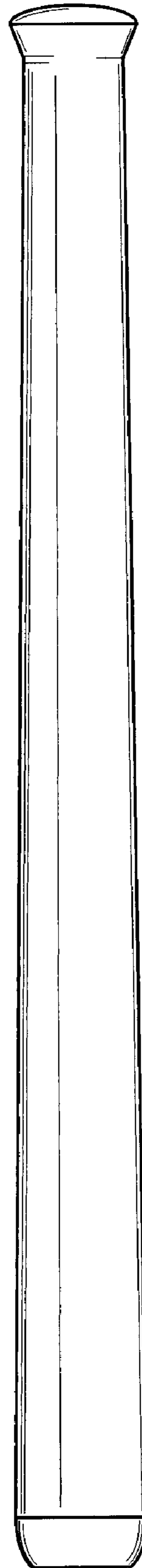

BOTTOM  
FIG. 5

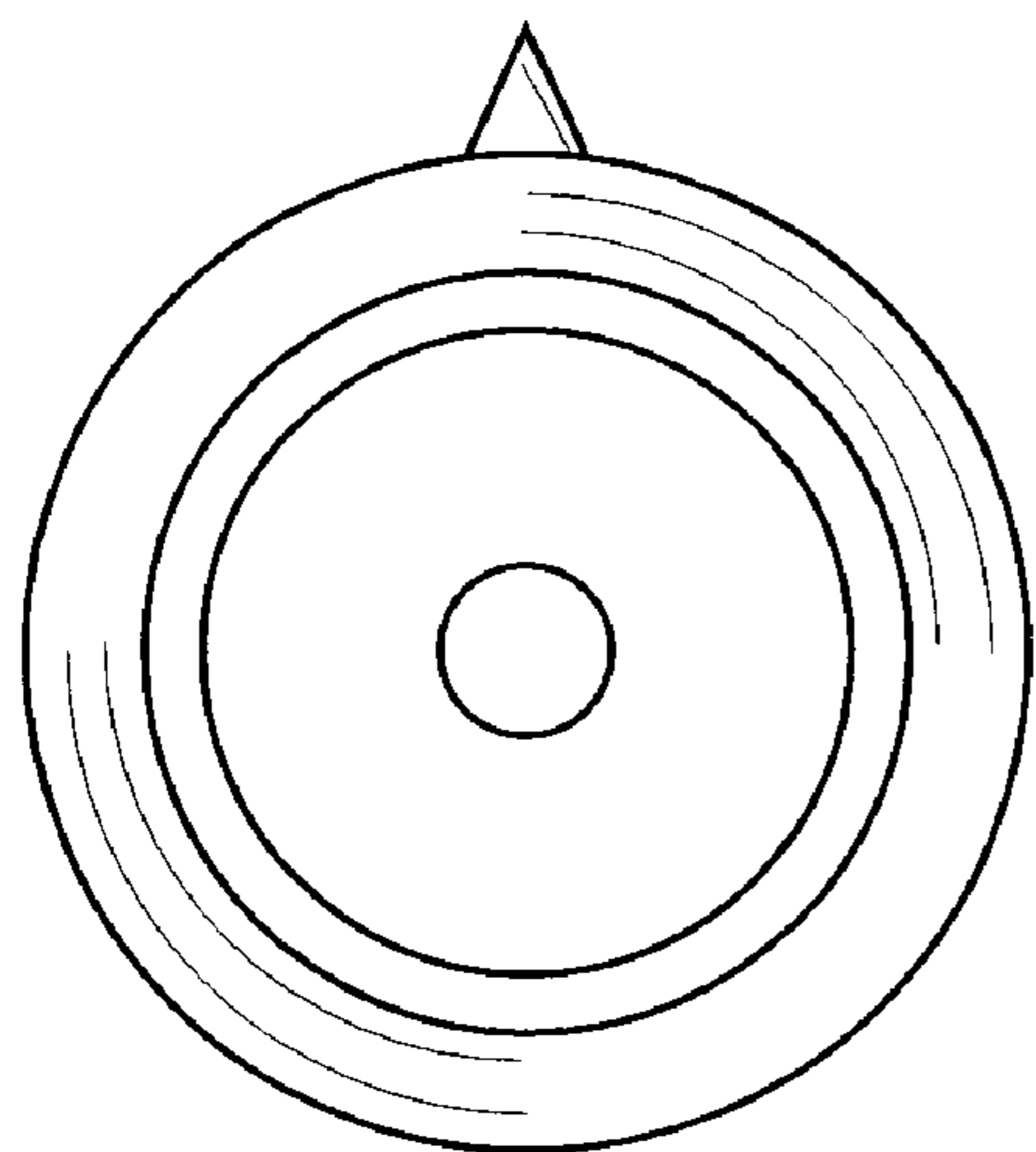

LEFT  
FIG. 7

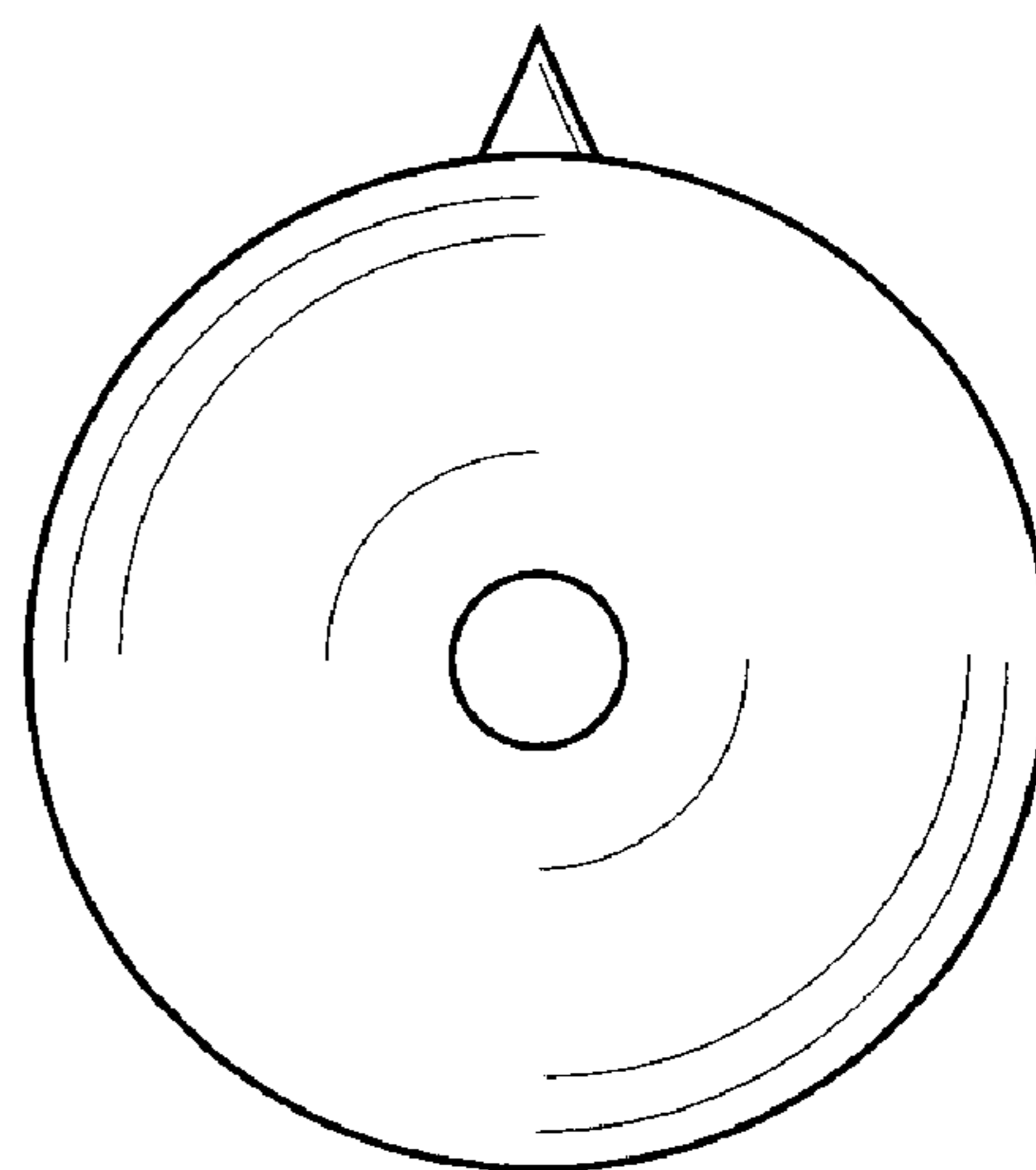

RIGHT  
FIG. 6