



US00D548153S

(12) **United States Design Patent**
Sherman

(10) **Patent No.:** **US D548,153 S**

(45) **Date of Patent:** **** Aug. 7, 2007**

(54) **DUAL CALIPER BRAKING COMPONENTS FOR FRONT WHEEL DRIVE VEHICLE**

Primary Examiner—Stacia Cadmus

(74) *Attorney, Agent, or Firm*—Richard L. Miller

(76) **Inventor:** **Gilbert L. Sherman**, 60 Hausch Blvd., Roosevelt, NY (US) 11575

(57) **CLAIM**

(**) **Term:** **14 Years**

The ornamental design for: dual caliper braking components for front wheel drive vehicle, as shown and described.

(21) **Appl. No.:** **29/243,765**

(22) **Filed:** **Nov. 30, 2005**

DESCRIPTION

(51) **LOC (8) Cl.** **12-16**

(52) **U.S. Cl.** **D12/180**

(58) **Field of Classification Search** D12/179–180, D12/400, 114; 192/107 R, 70.16; 188/72.5, 188/72.6, 73.2, 73.39, 73.31, 73.45, 71.1, 188/73.3, 71.3, 73.1, 209–211, 218 XL, 24.11–24.13, 188/24.22

See application file for complete search history.

FIG. 1 is a front elevational view showing my new design for a left side dual caliper braking component for a front wheel drive vehicle, the corresponding view for the right side dual caliper braking component being a mirror image thereof;

(56) **References Cited**

U.S. PATENT DOCUMENTS

4,505,363	A	3/1985	Herbulot et al.	
4,800,993	A	1/1989	Weber	
4,993,519	A	2/1991	Thioux	
5,168,963	A	12/1992	Poncini	
D337,981	S *	8/1993	Steinke et al.	D12/180
5,363,943	A	11/1994	Iwashita et al.	
D378,363	S *	3/1997	Sin	D12/180
5,810,121	A	9/1998	Anger et al.	
5,921,354	A	7/1999	Evans	
D426,180	S *	6/2000	Pink et al.	D12/180
D437,274	S *	2/2001	Terasawa	D12/180
D437,813	S *	2/2001	Terasawa	D12/180
D439,873	S *	4/2001	Terasawa	D12/180
D458,199	S *	6/2002	Demoise et al.	D12/180
D508,001	S *	8/2005	Matsumoto	D12/180
D512,946	S *	12/2005	Hatakoshi et al.	D12/180
D522,421	S *	6/2006	Crippa et al.	D12/180
D523,794	S *	6/2006	Strumbo et al.	D12/180

FIG. 2 is a bottom elevational view of a left side dual caliper braking component for a front wheel drive vehicle, the corresponding view for the right side dual caliper braking component being a mirror image thereof;

FIG. 3 is a rear elevational view of a left side dual caliper braking component for a front wheel drive vehicle, the corresponding view for the right side dual caliper braking component being a mirror image thereof;

FIG. 4 is a top elevational view of a left side dual caliper braking component for a front wheel drive vehicle, the corresponding view for the right side dual caliper braking component being a mirror image thereof;

FIG. 5 is a right side elevational view of a left side dual caliper braking component for a front wheel drive vehicle, the corresponding view for the right side dual caliper braking component being a mirror image thereof; and,

FIG. 6 is a left side elevational view of a left side dual caliper braking component for a front wheel drive vehicle, the corresponding view for the right side dual caliper braking component being a mirror image thereof.

* cited by examiner

1 Claim, 3 Drawing Sheets

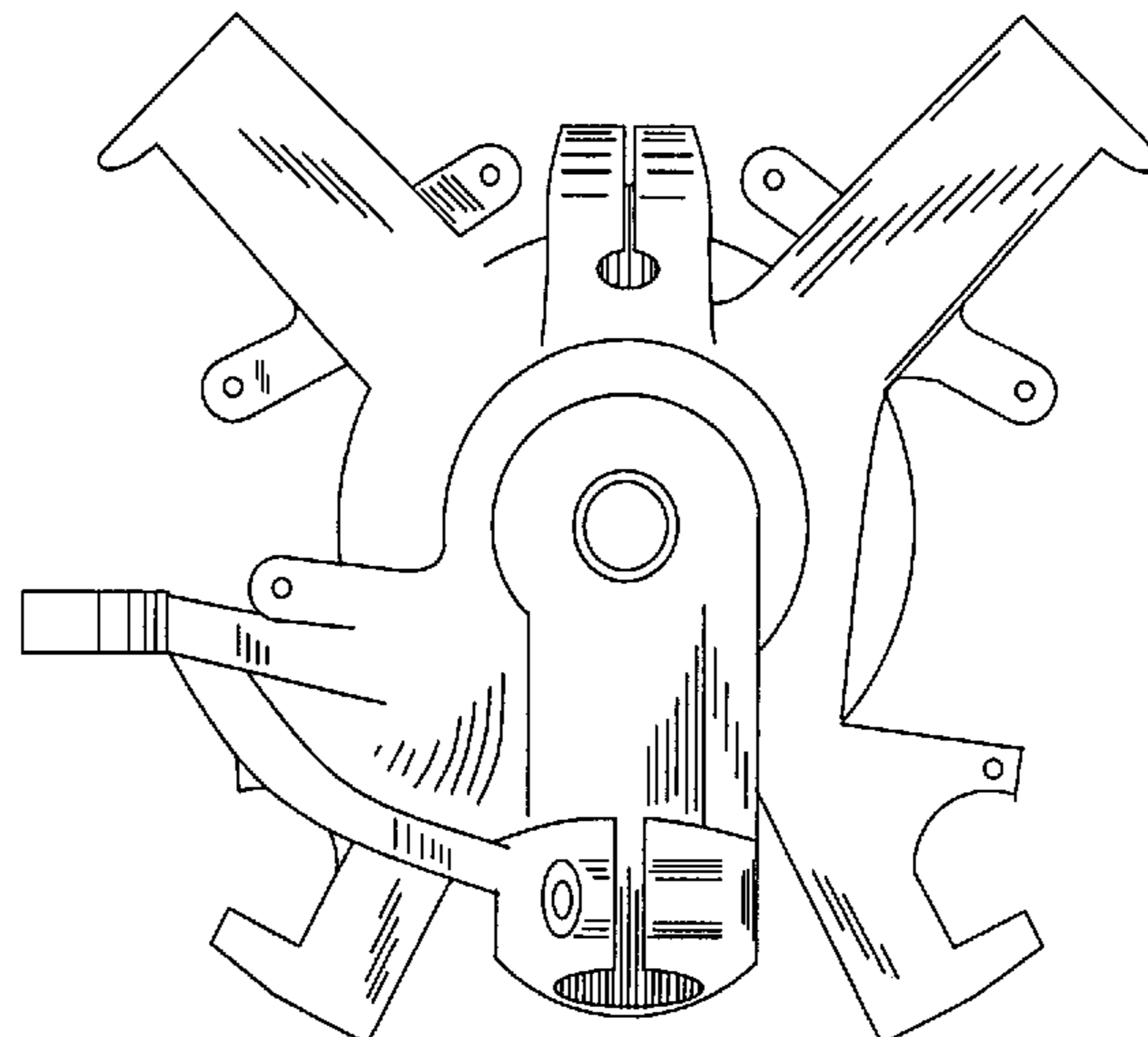
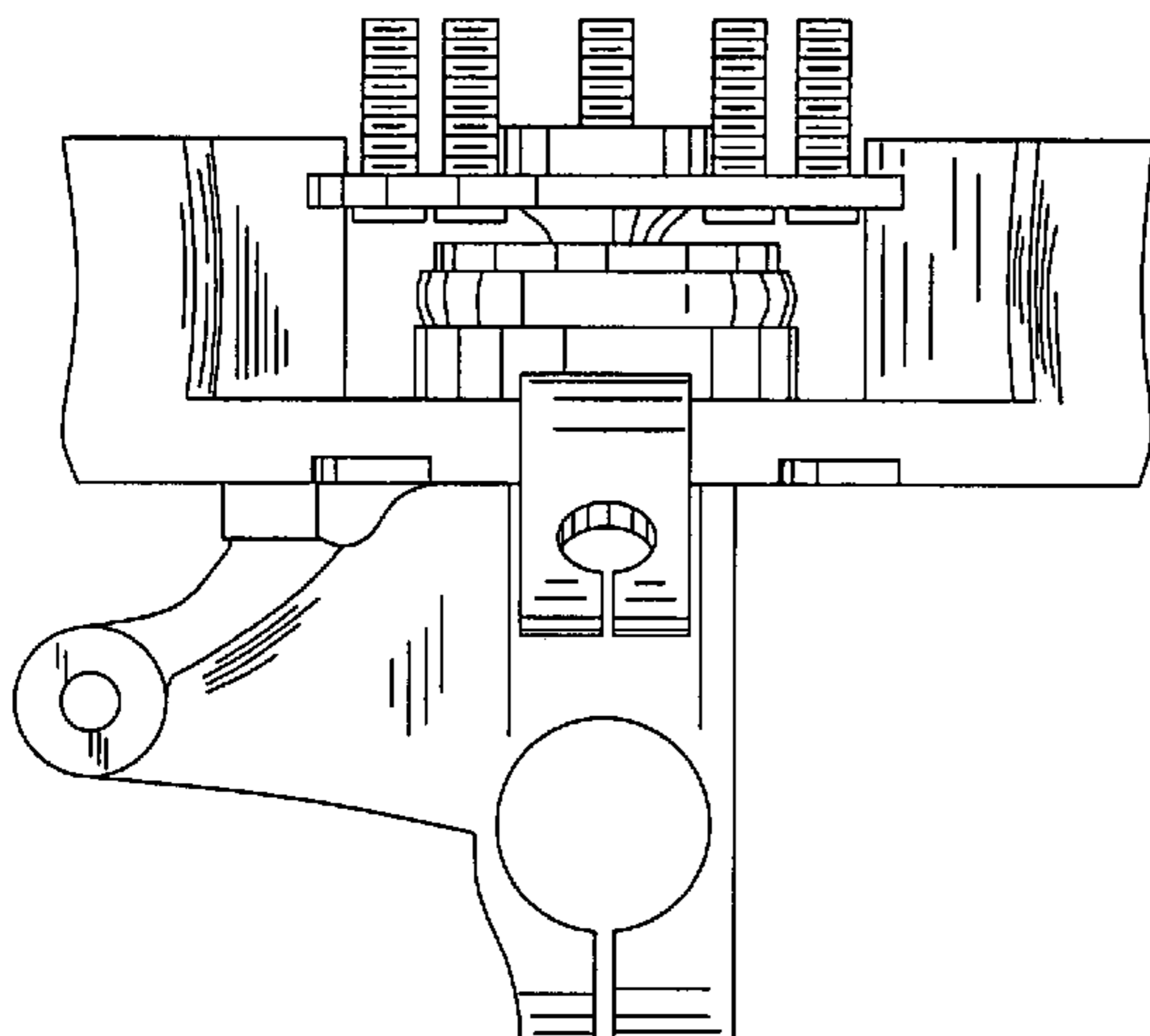

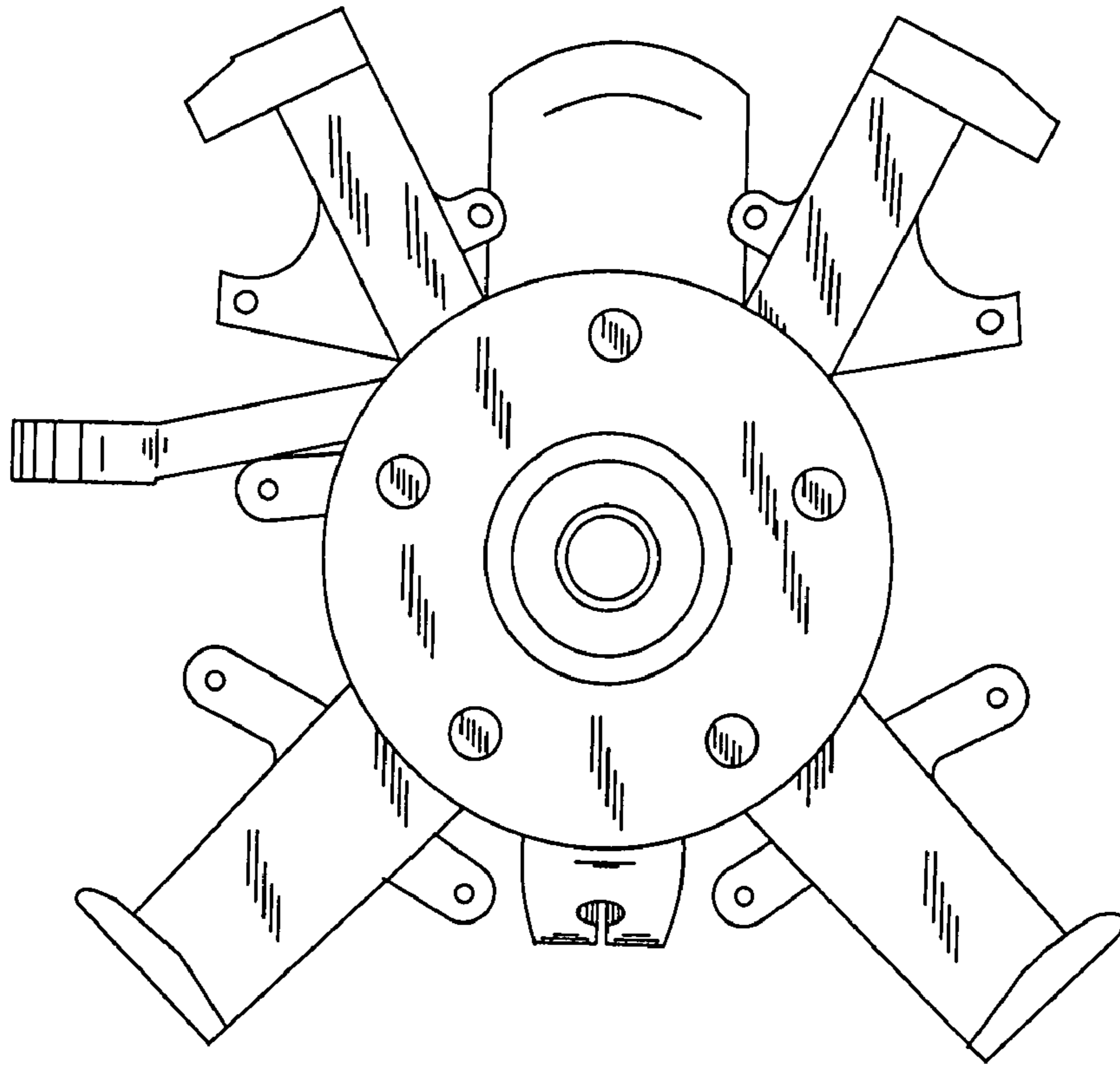

FIG. 1

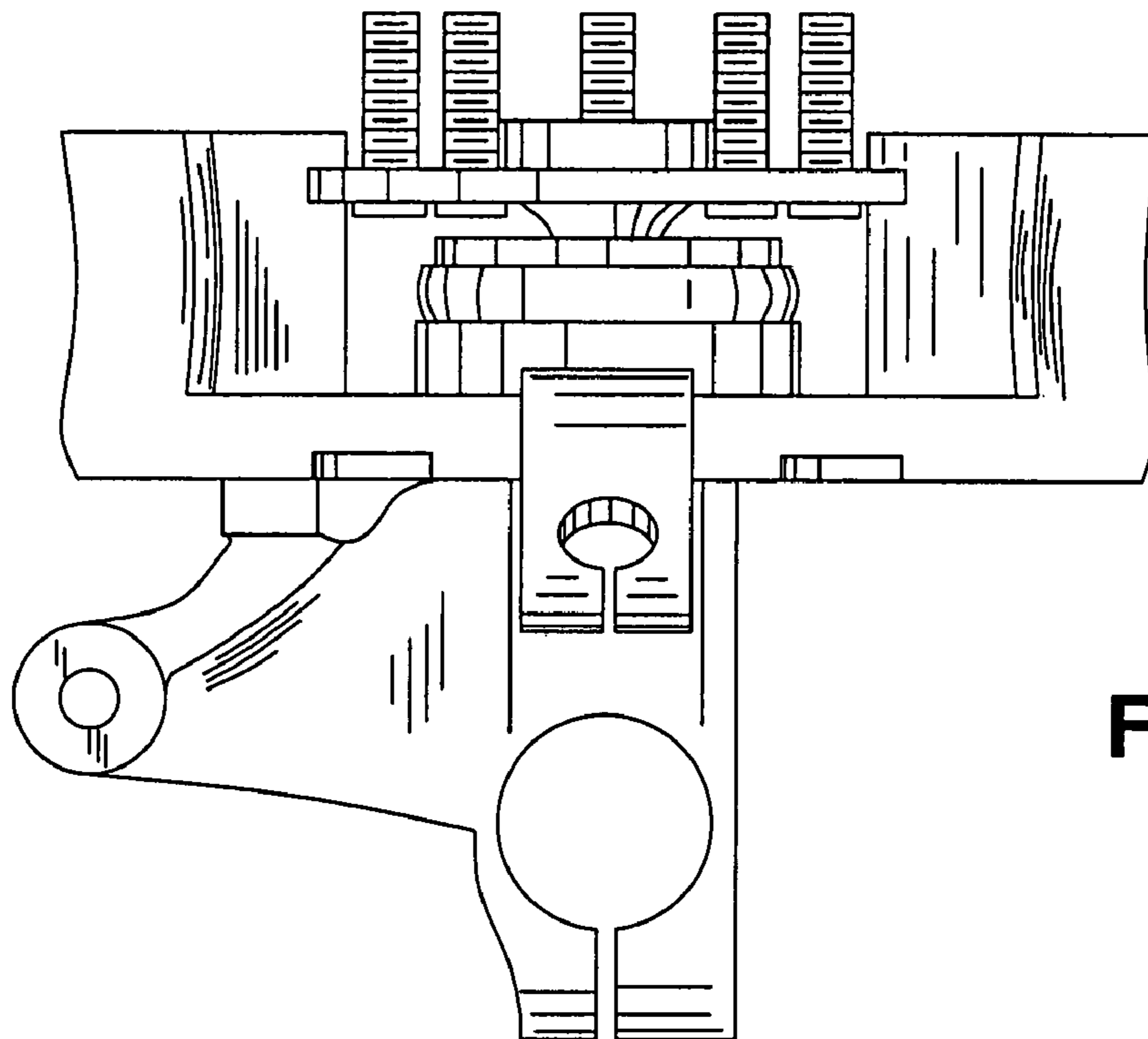

FIG. 2

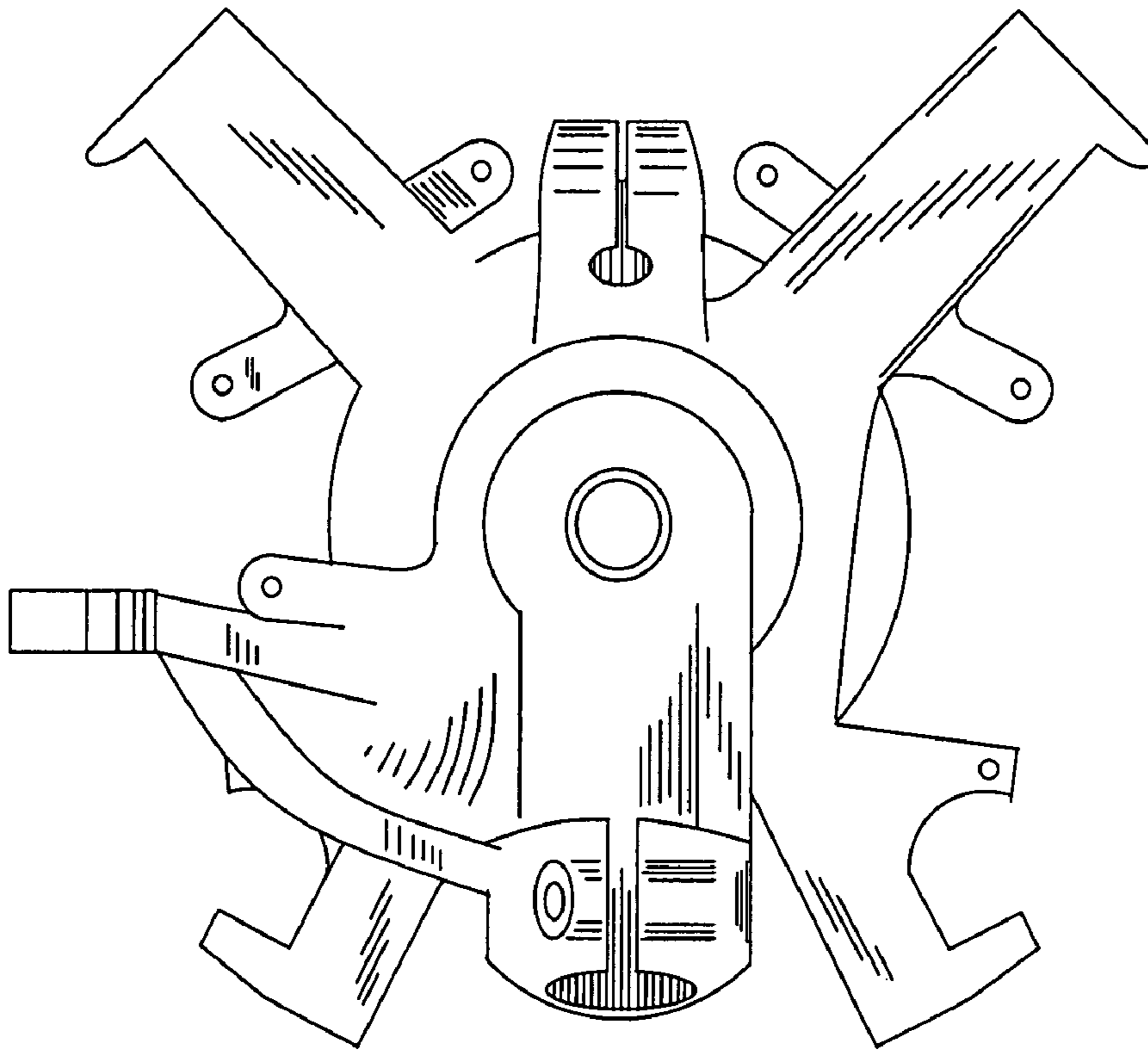

FIG. 3

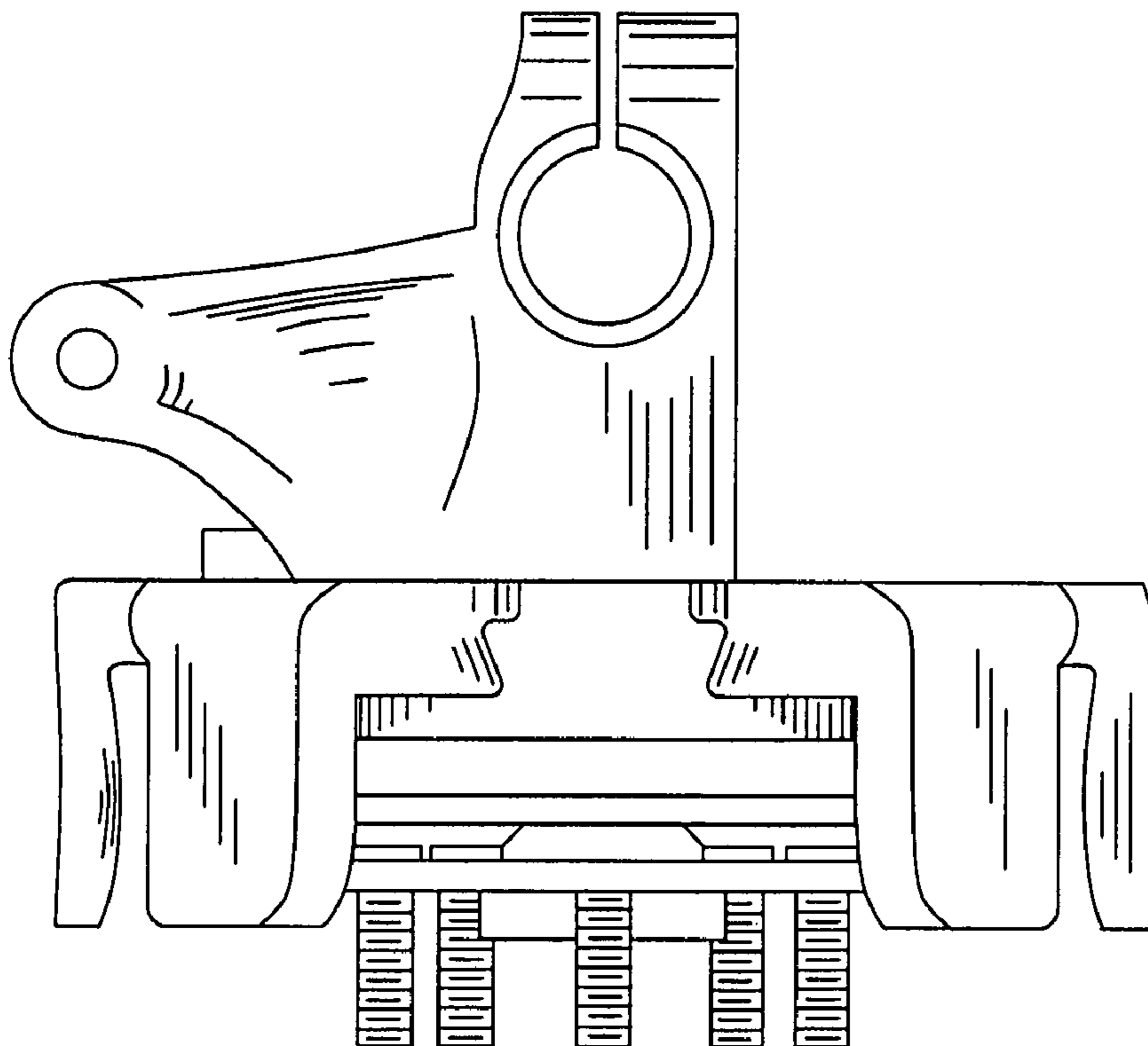

FIG. 4

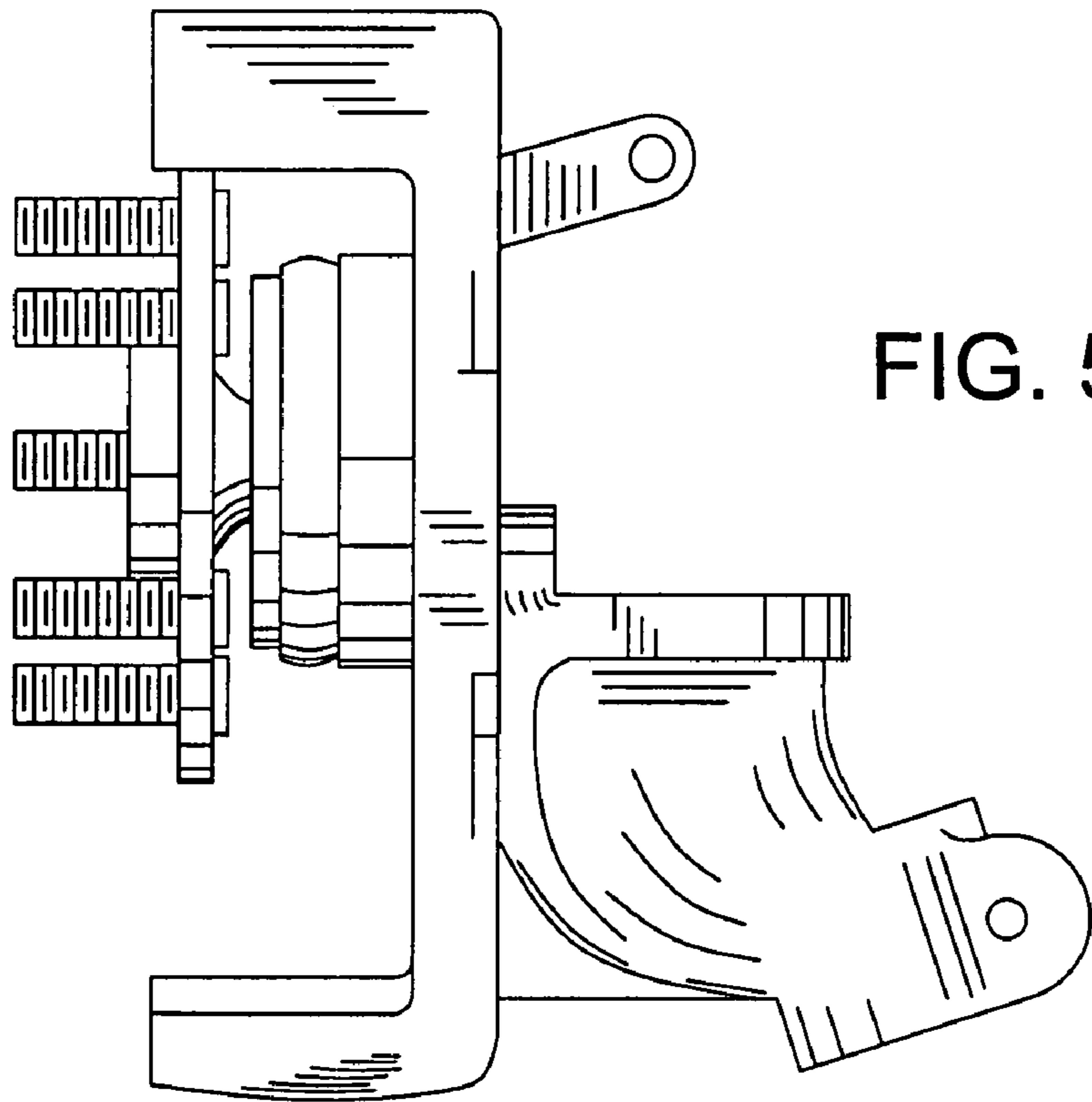

FIG. 5

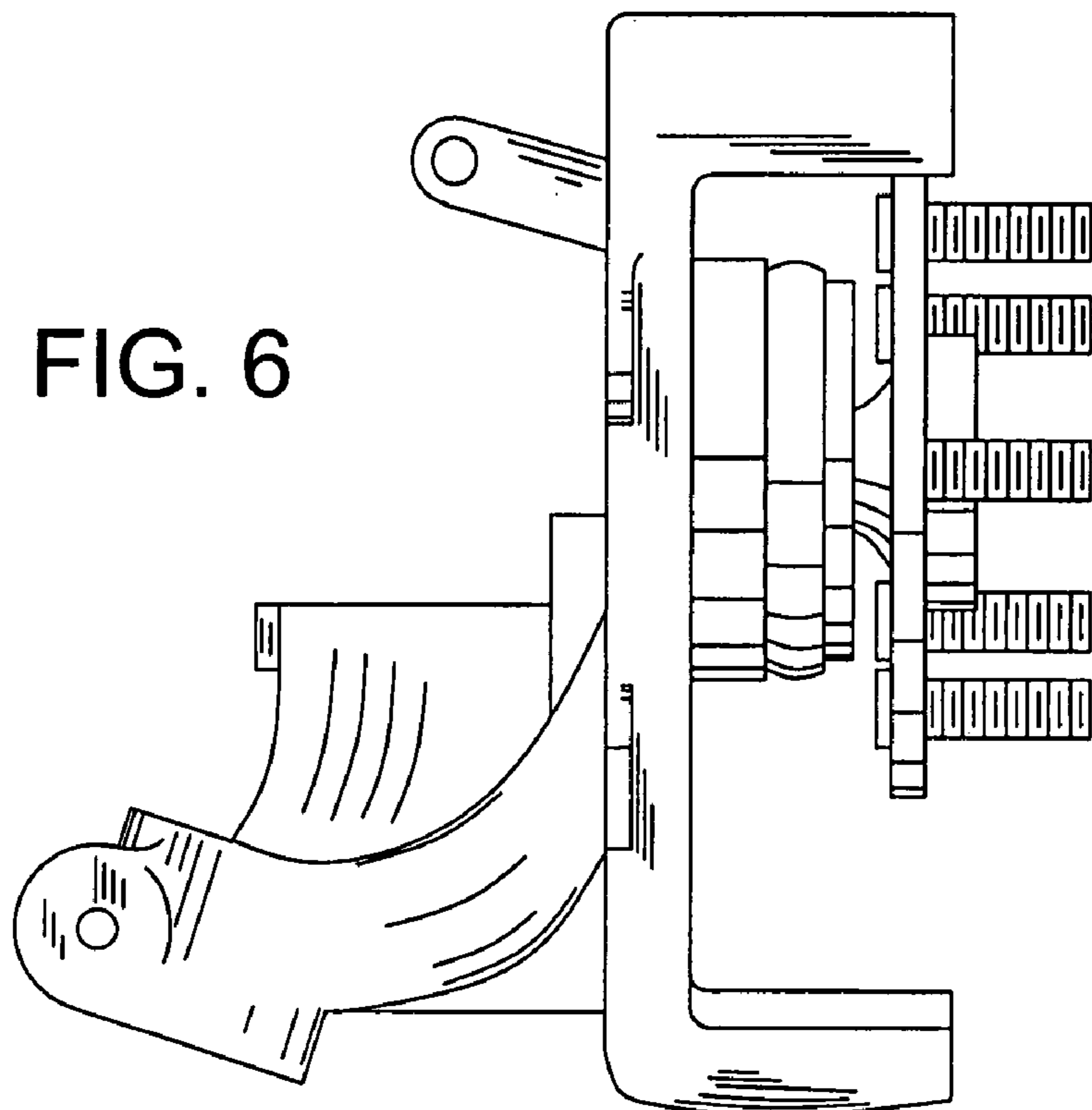

FIG. 6