



US00D547749S

(12) **United States Design Patent**  
**Meyer et al.**

(10) **Patent No.:** **US D547,749 S**  
(45) **Date of Patent:** **\*\* Jul. 31, 2007**

(54) **LOUDSPEAKER**

(76) Inventors: **Perrin Meyer**, 1531 Posen Ave., Albany, CA (US) 94706; **John D. Meyer**, 928 Arlington Ave., Berkeley, CA (US) 94707; **Bruce T. Arasato**, 3443 Beard Rd., Fremont, CA (US) 94555; **Alejandro Antonio Garcia Rubio**, 2130 Sixth St., Berkeley, CA (US) 94710

(\*\*) Term: **14 Years**

(21) Appl. No.: **29/236,841**

(22) Filed: **Aug. 24, 2005**

(51) **LOC (8) Cl.** ..... **14-01**

(52) **U.S. Cl.** ..... **D14/214**

(58) **Field of Classification Search** ..... D14/204,  
D14/207, 209–216, 356; 181/143–144, 147–148,  
181/150, 157, 198–199, 151, 153; 381/300–302,  
381/306, 333, 345, 361–364, 386–388, 332,  
381/336

See application file for complete search history.

(56) **References Cited**

**U.S. PATENT DOCUMENTS**

D197,611 S	*	3/1964	Yang	.....	D14/214
D271,967 S		12/1983	Meyer et al.		
D277,278 S	*	1/1985	Matsuda	.....	D14/214
D305,892 S	*	2/1990	Freed	.....	D14/213
D375,499 S		11/1996	Meyer		
D419,158 S	*	1/2000	Mackie et al.	.....	D14/214
D439,238 S	*	3/2001	Mackie et al.	.....	D14/214
D468,292 S	*	1/2003	Nugent et al.	.....	D14/215
D496,352 S	*	9/2004	Crook et al.	.....	D14/214

**OTHER PUBLICATIONS**

PSM-2 Self-Powered Stage Monitor, Meyer Sound Laboratories, Incorporated, 1998.

650-P Self-Powered Reinforcement Subwoofer, Meyer Sound Laboratories, Incorporated, 1997.

DF-4 Self-Powered Dedicated Downfill Loudspeaker System, Meyer Sound Laboratories, Incorporated, 2001.

MSL-4 Self-Powered Reinforcement Loudspeaker, Meyer Sound Laboratories, Incorporated, 1997.

PSW-6 Self-Powered Cardioid Subwoofer, Meyer Sound Laboratories, Incorporated, 1998.

MSL-6 Self-Powered Loudspeaker, Meyer Sound Laboratories, Incorporated, 1998.

\* cited by examiner

*Primary Examiner*—Nanda Bondade

(74) *Attorney, Agent, or Firm*—Donald L. Beeson; Beeson Skinner Beverly, LLP

(57) **CLAIM**

The ornamental design for a loudspeaker, as shown and described.

**DESCRIPTION**

FIG. 1 is a top perspective view of a loudspeaker showing our new design;

FIG. 2 is a front elevational view thereof;

FIG. 3 is a right side elevational view thereof, the left side being a mirror image;

FIG. 4 is a rear elevational view thereof;

FIG. 5 is a top plan view thereof; and

FIG. 6 is a bottom plan view thereof.

FIG. 7 is a top perspective view of a loudspeaker showing an alternative embodiment of our new design.

FIG. 8 is a front elevational view thereof;

FIG. 9 is a right side elevational view thereof, the left side being a mirror image;

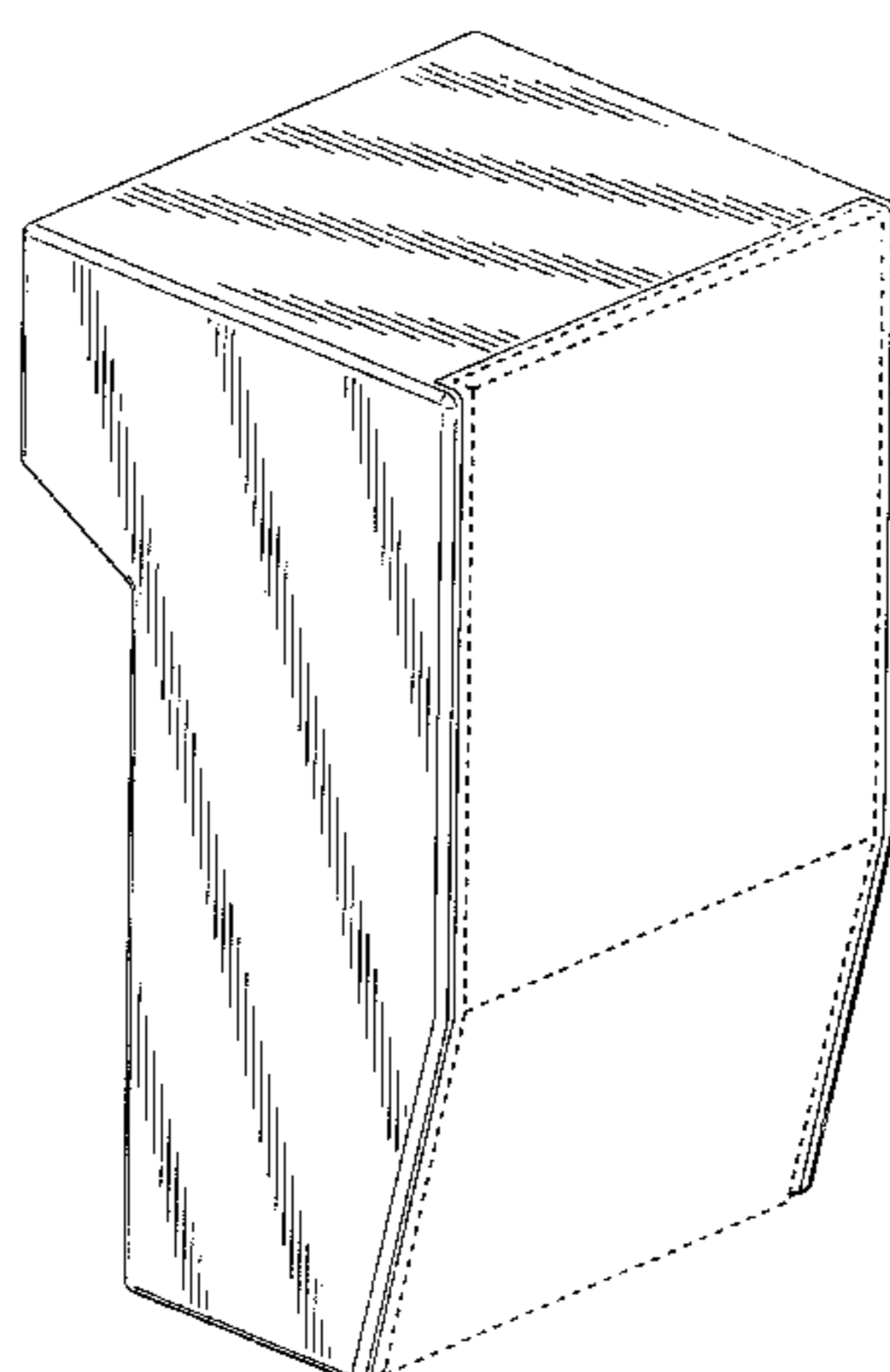
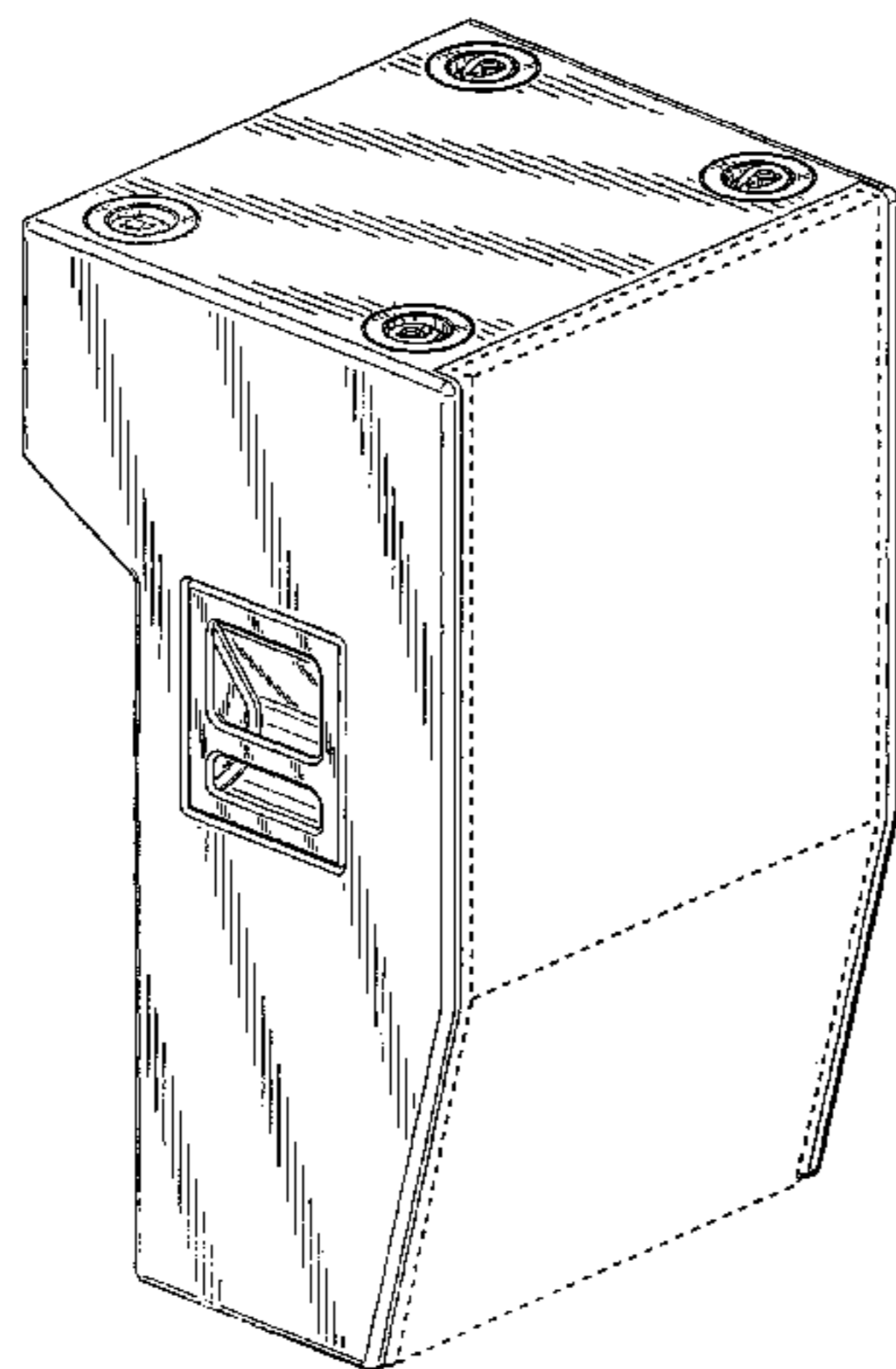
FIG. 10 is a rear elevational view thereof;

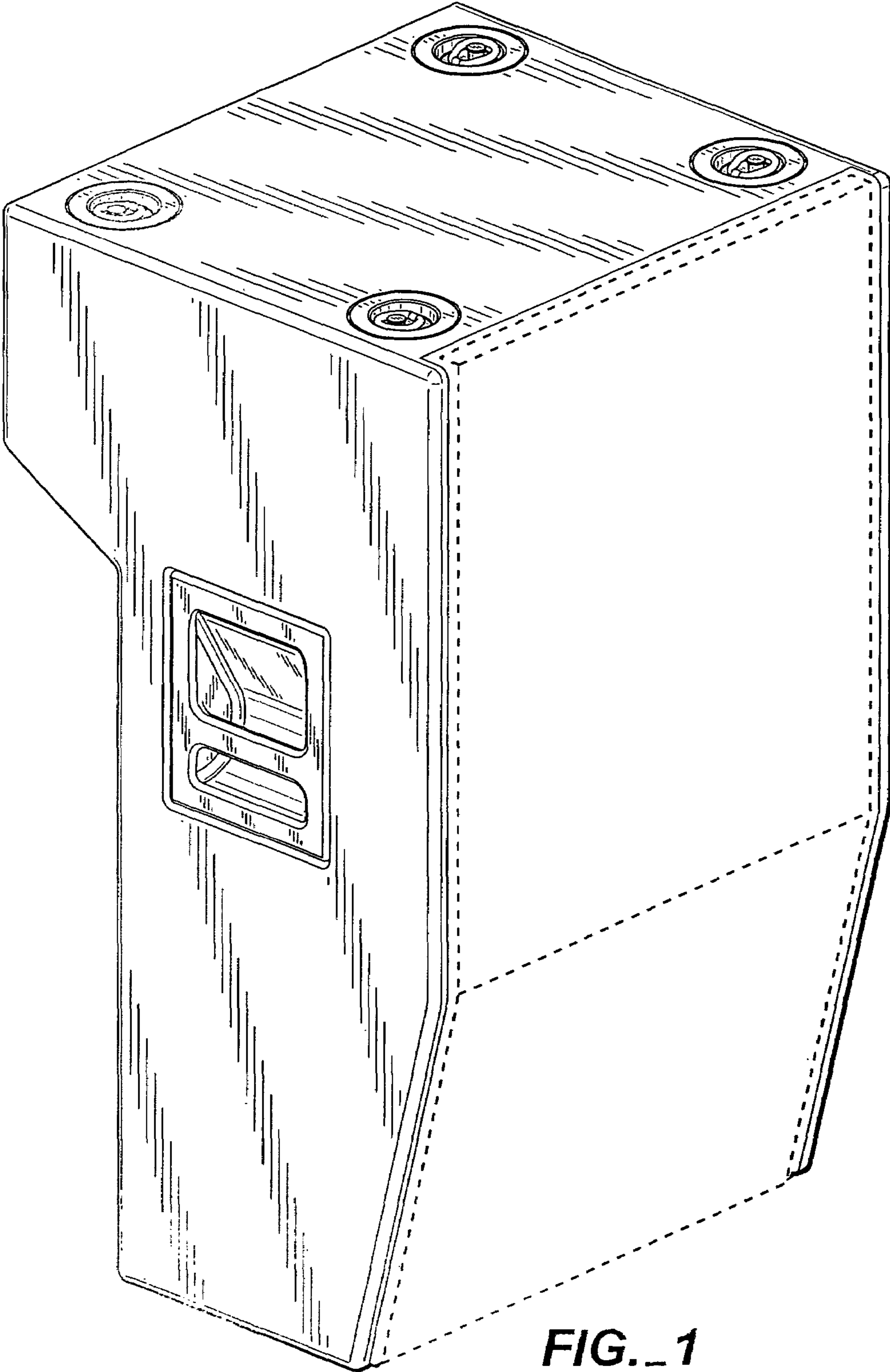
FIG. 11 is a top plan view thereof; and,

FIG. 12 is a bottom plan view thereof.

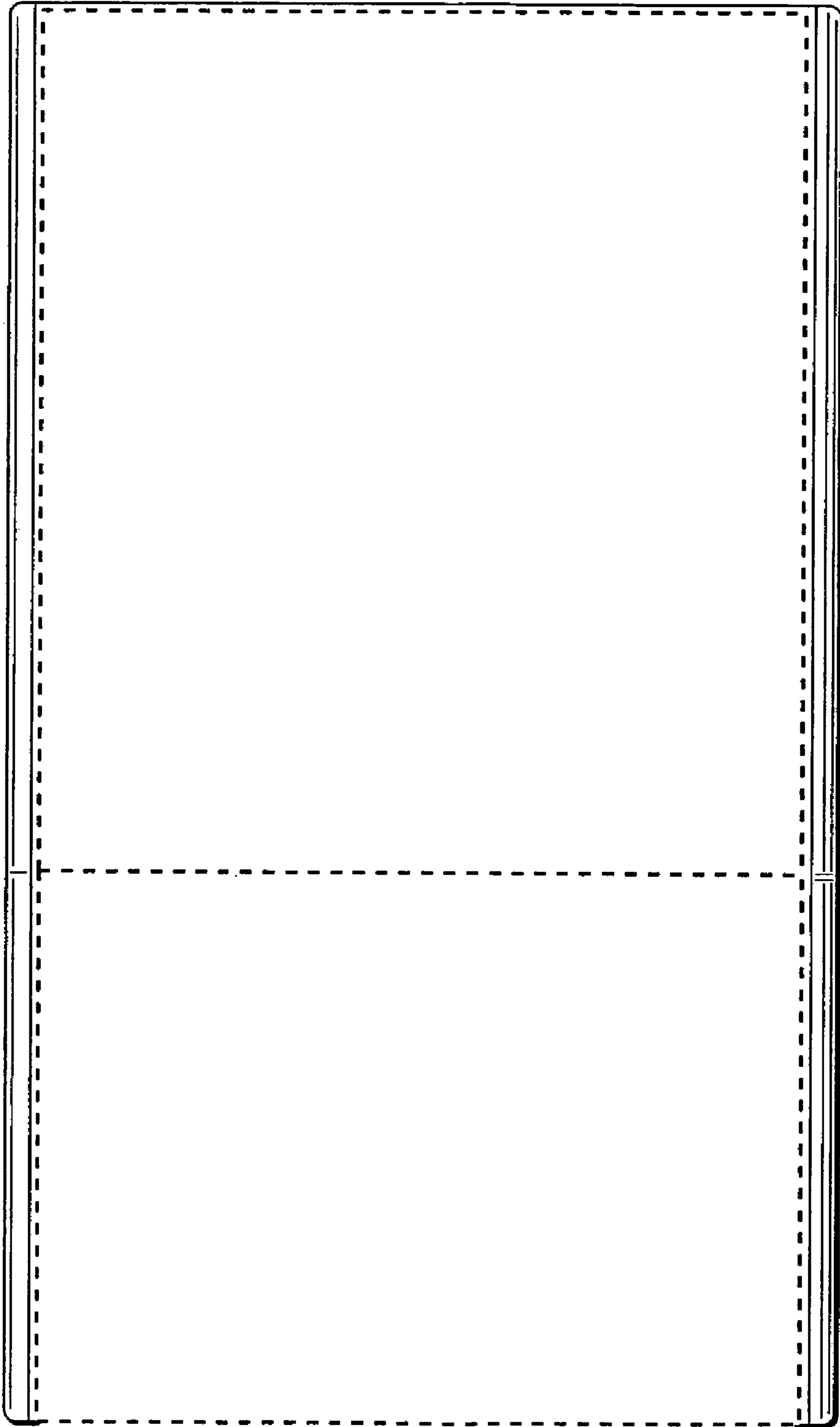
The broken lines in FIGS. 1–12 represent the bounds of the claimed design; the region within these broken lines forms no part of our claimed design.

**1 Claim, 10 Drawing Sheets**

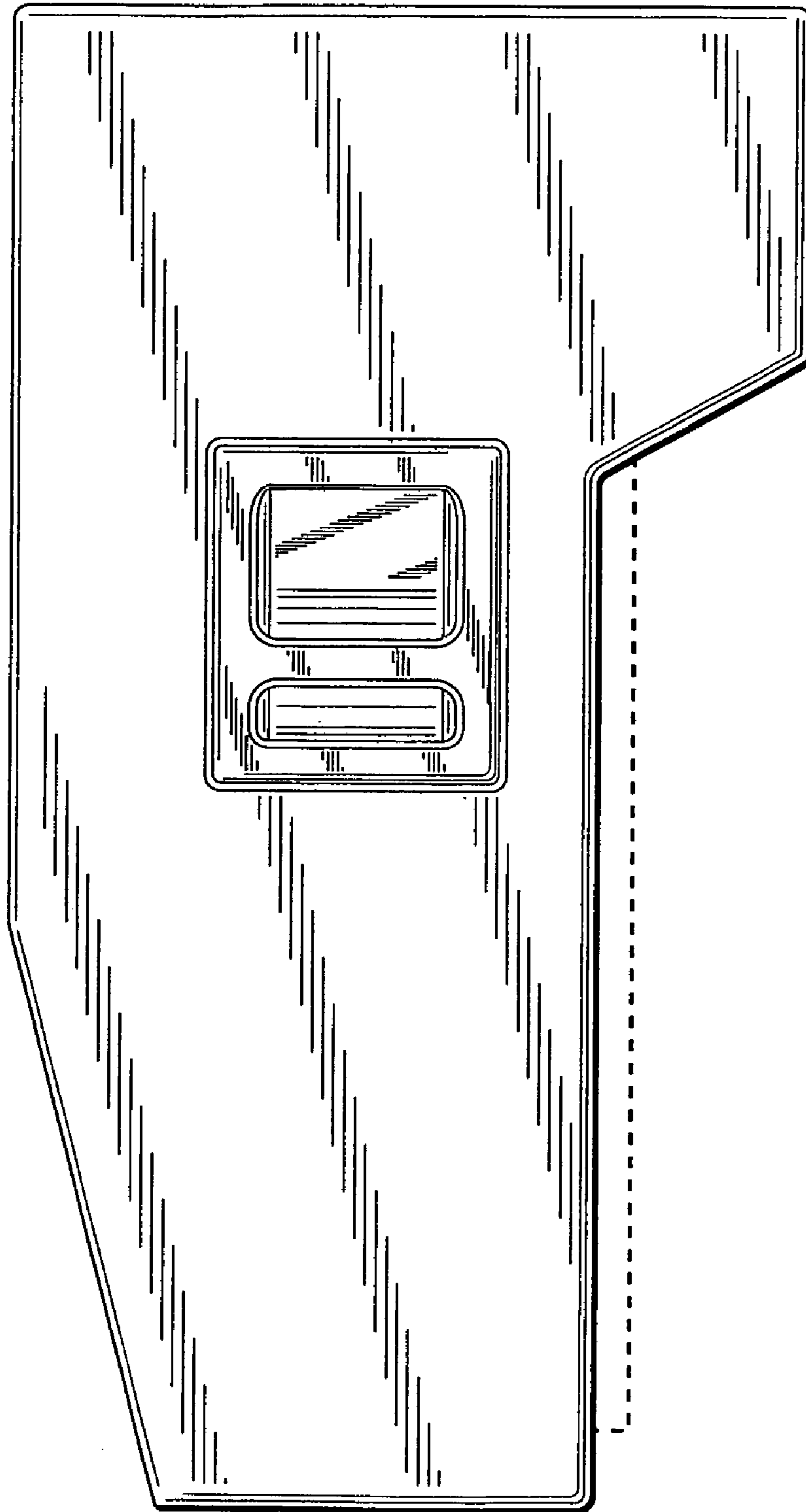




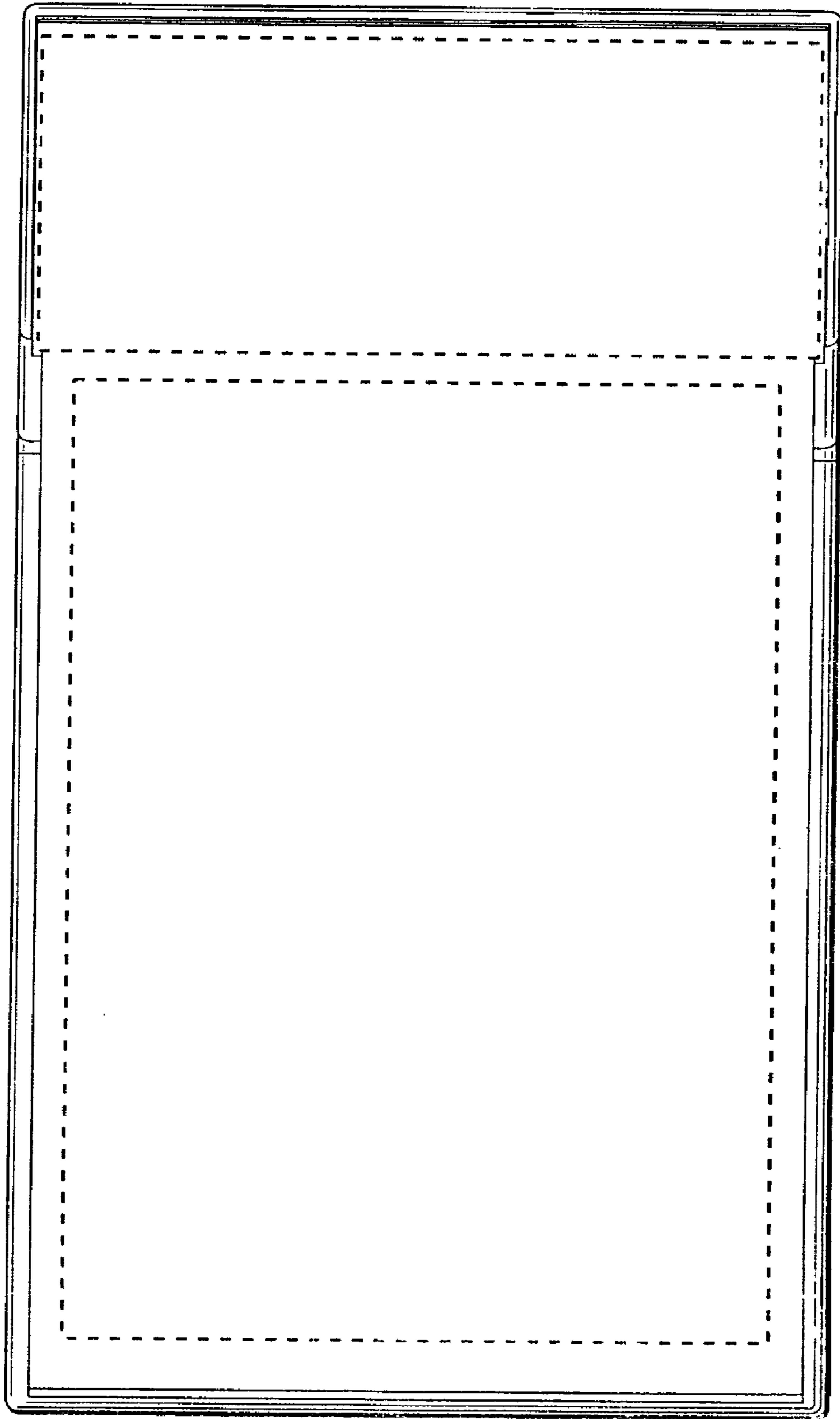
**FIG. 1**



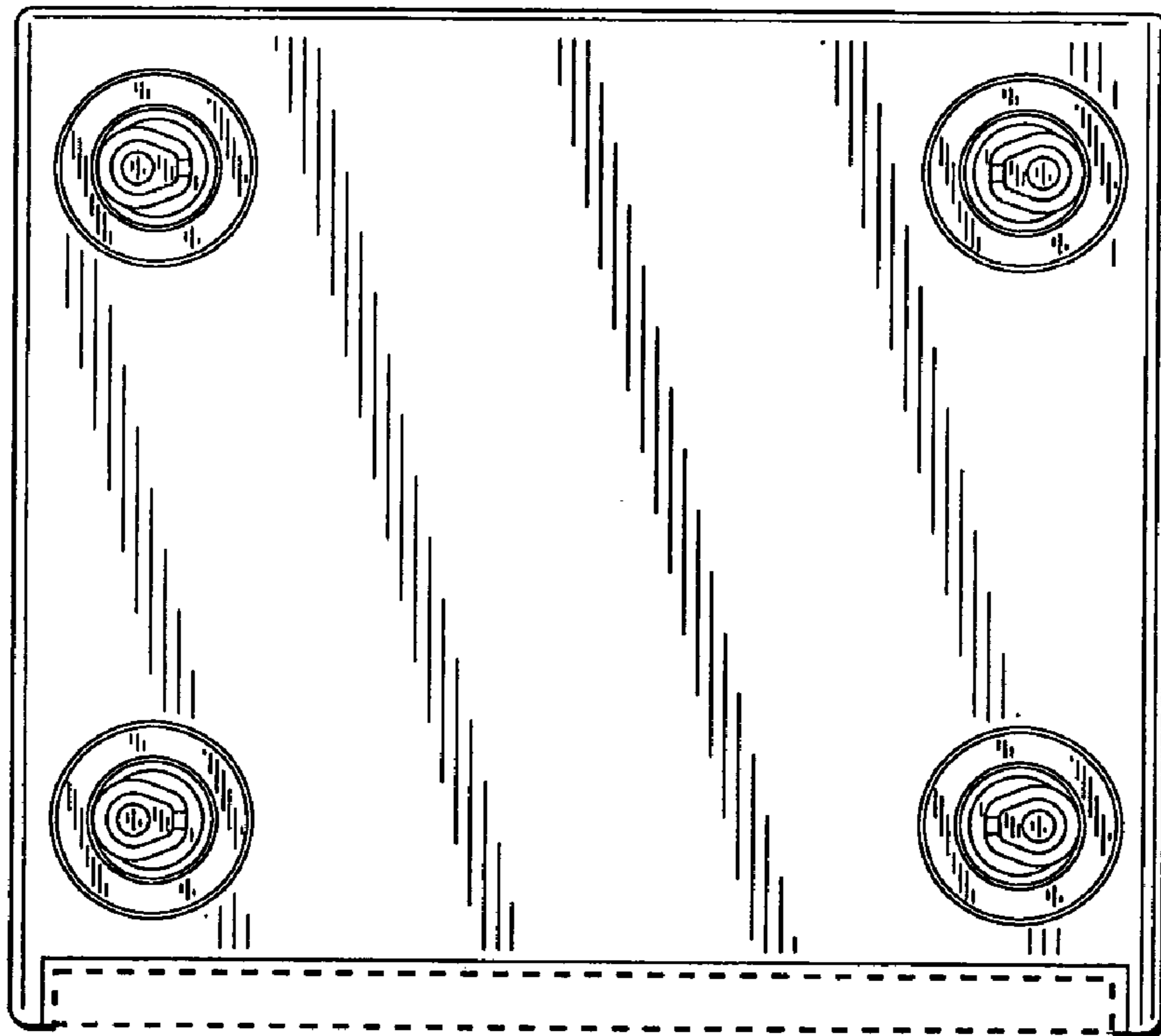
**FIG. 2**



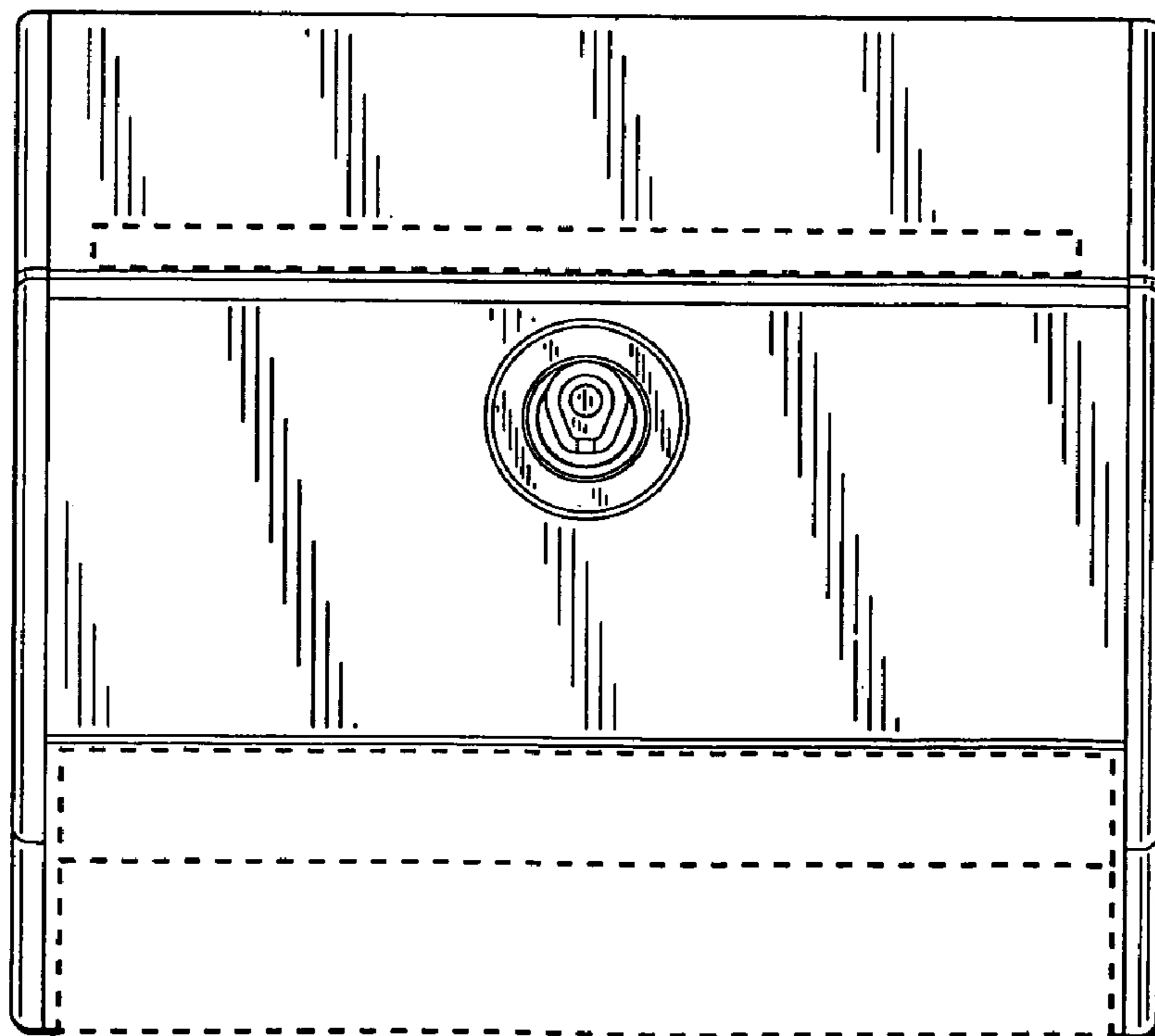
**FIG. 3**



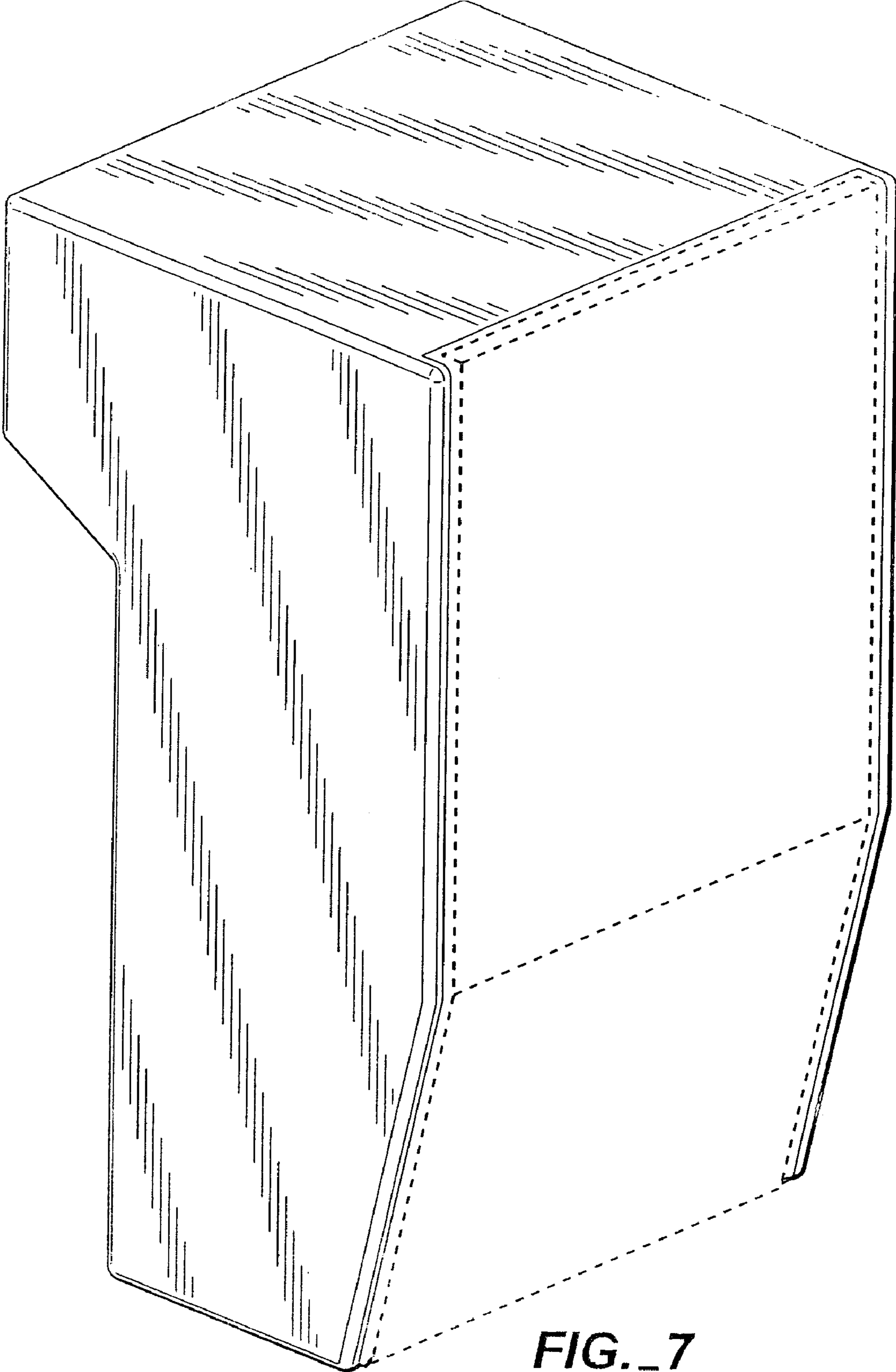
**FIG. 4**

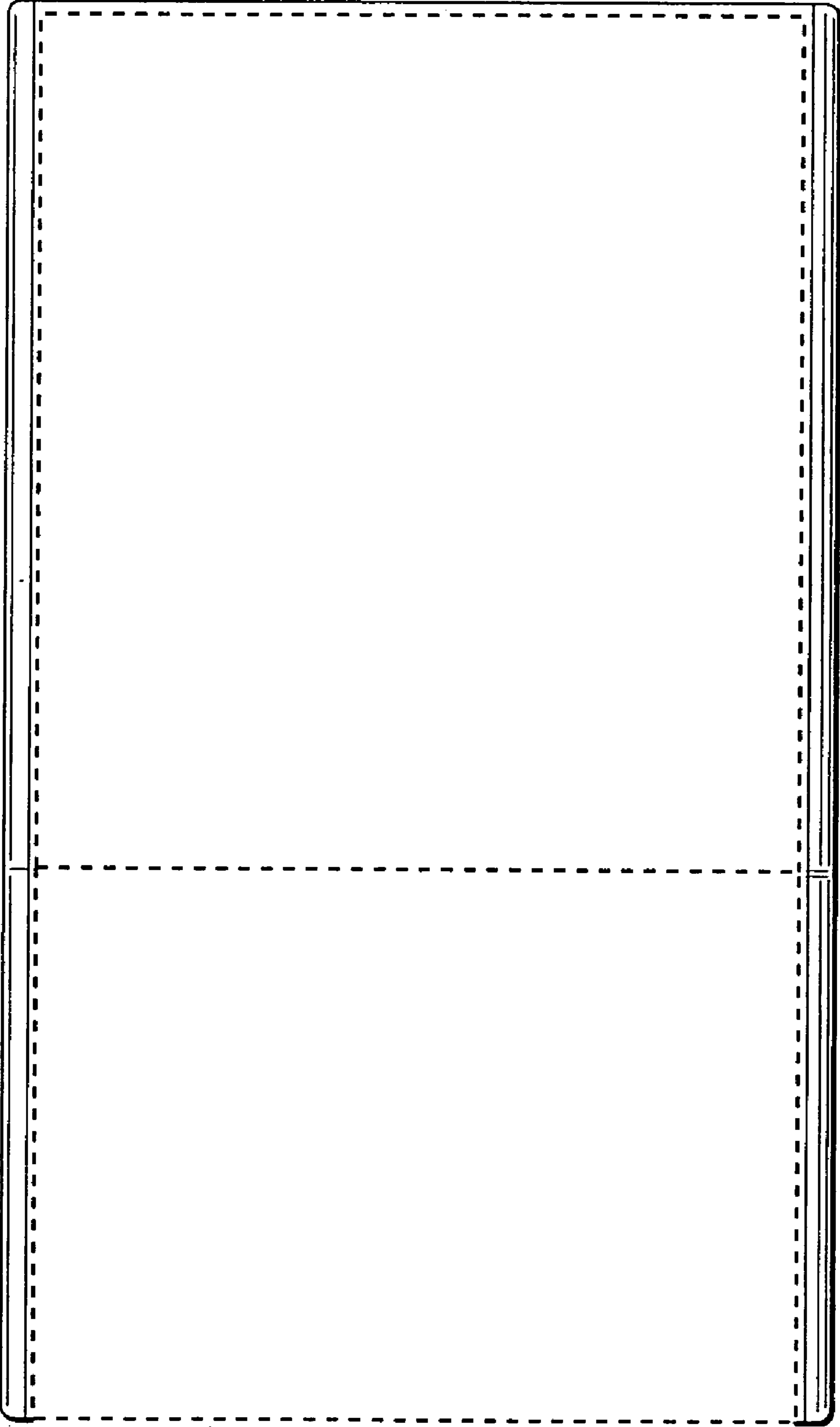


**FIG. 5**



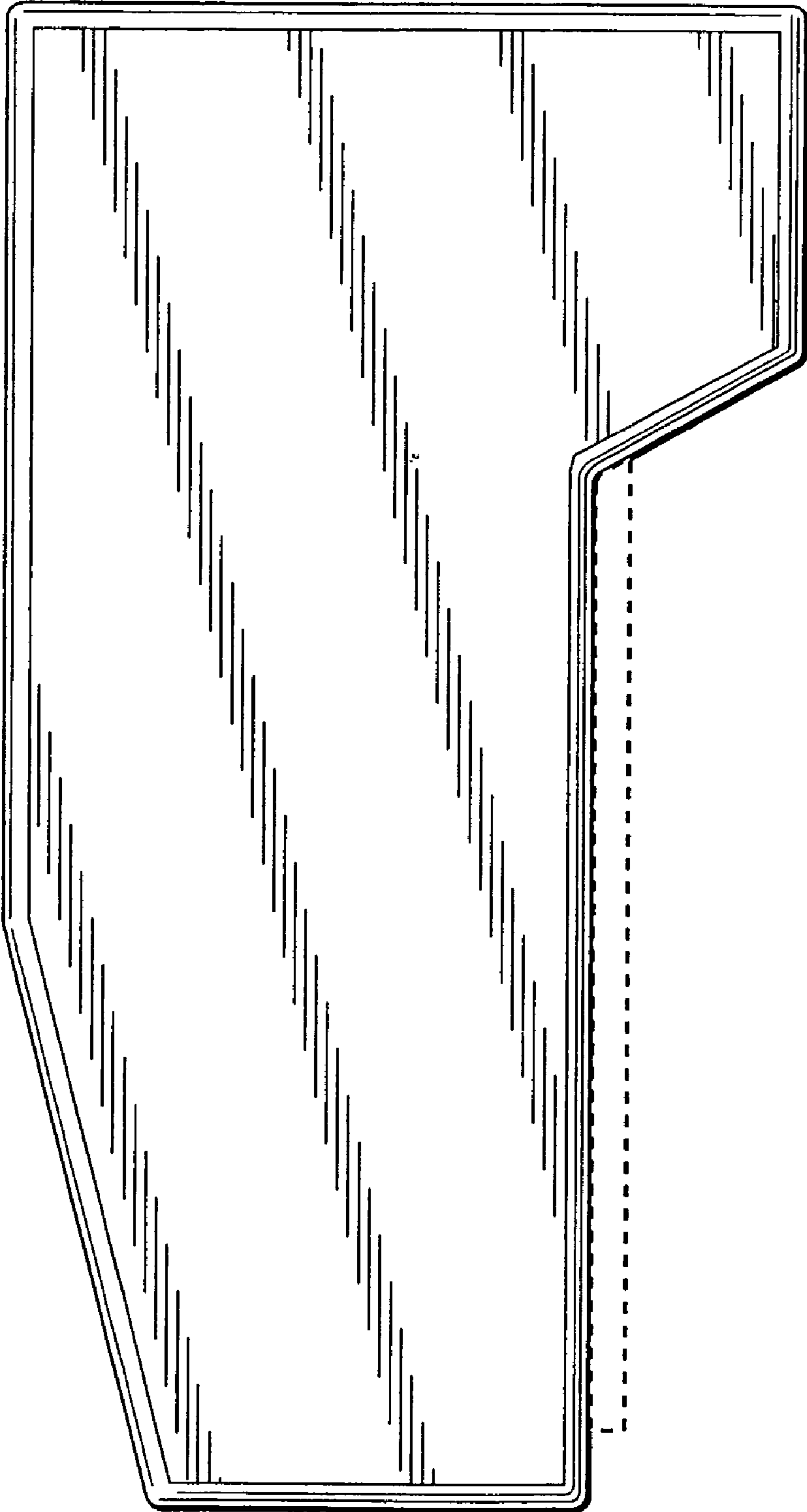
**FIG. 6**



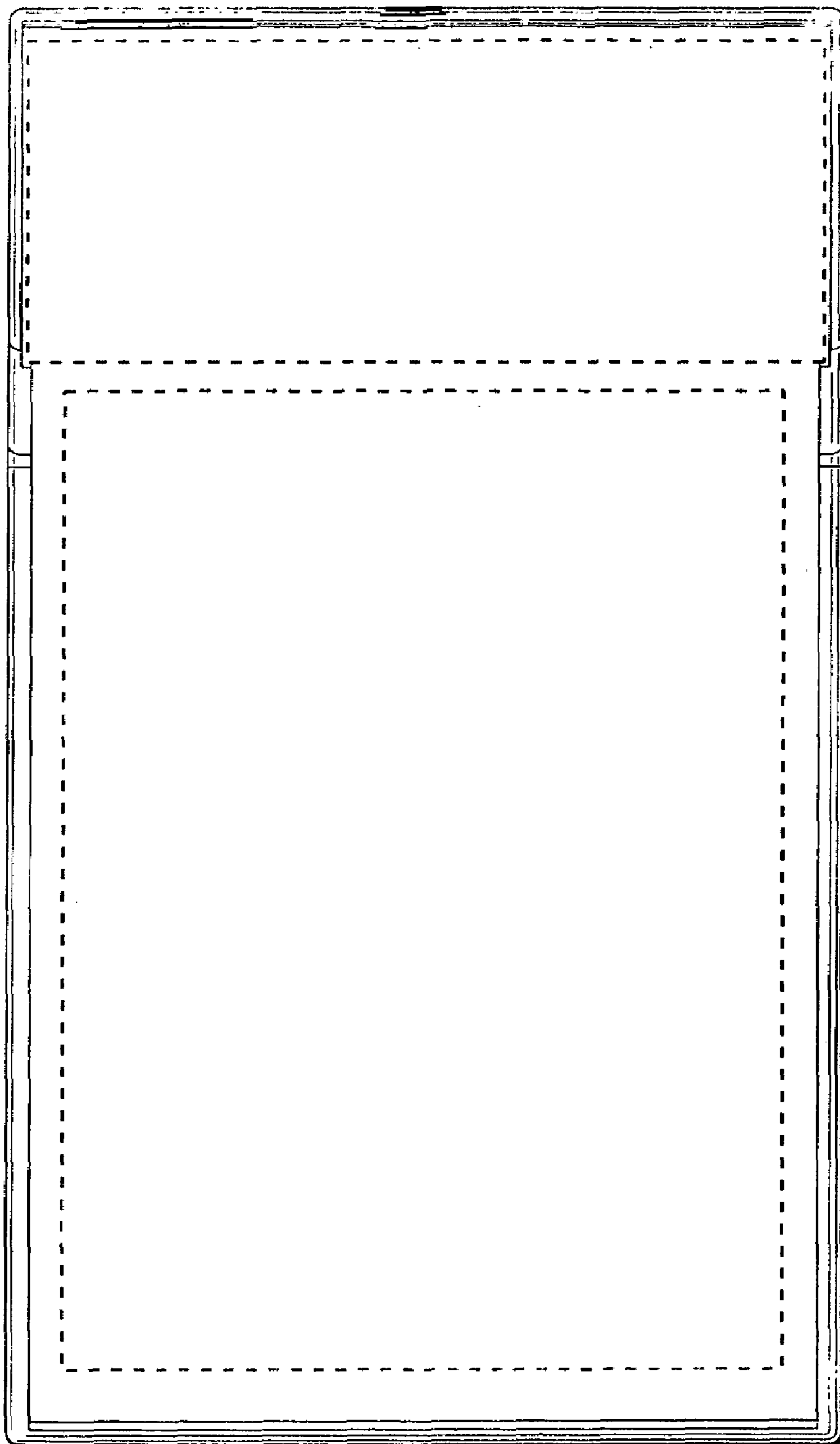


**FIG. 8**

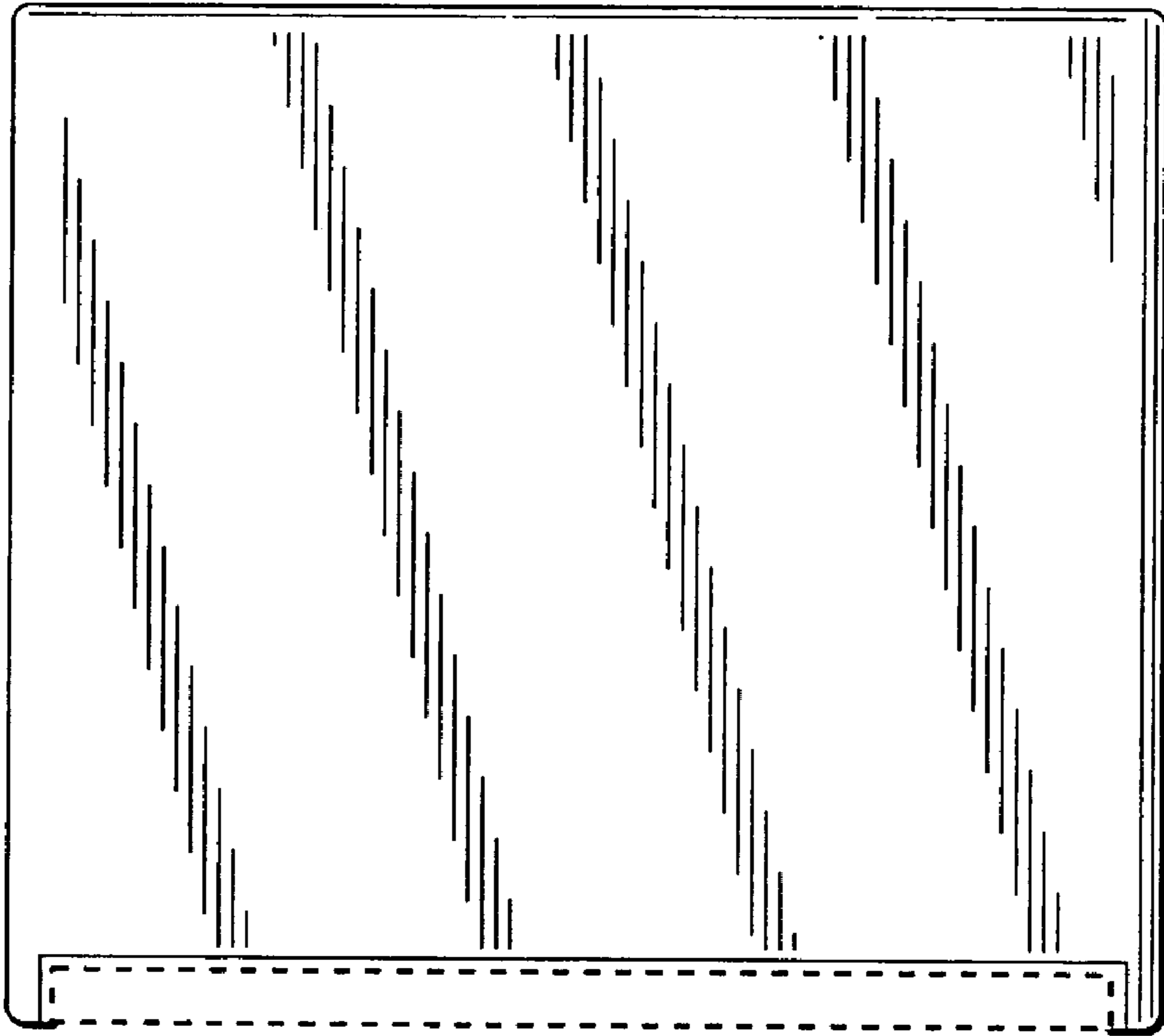




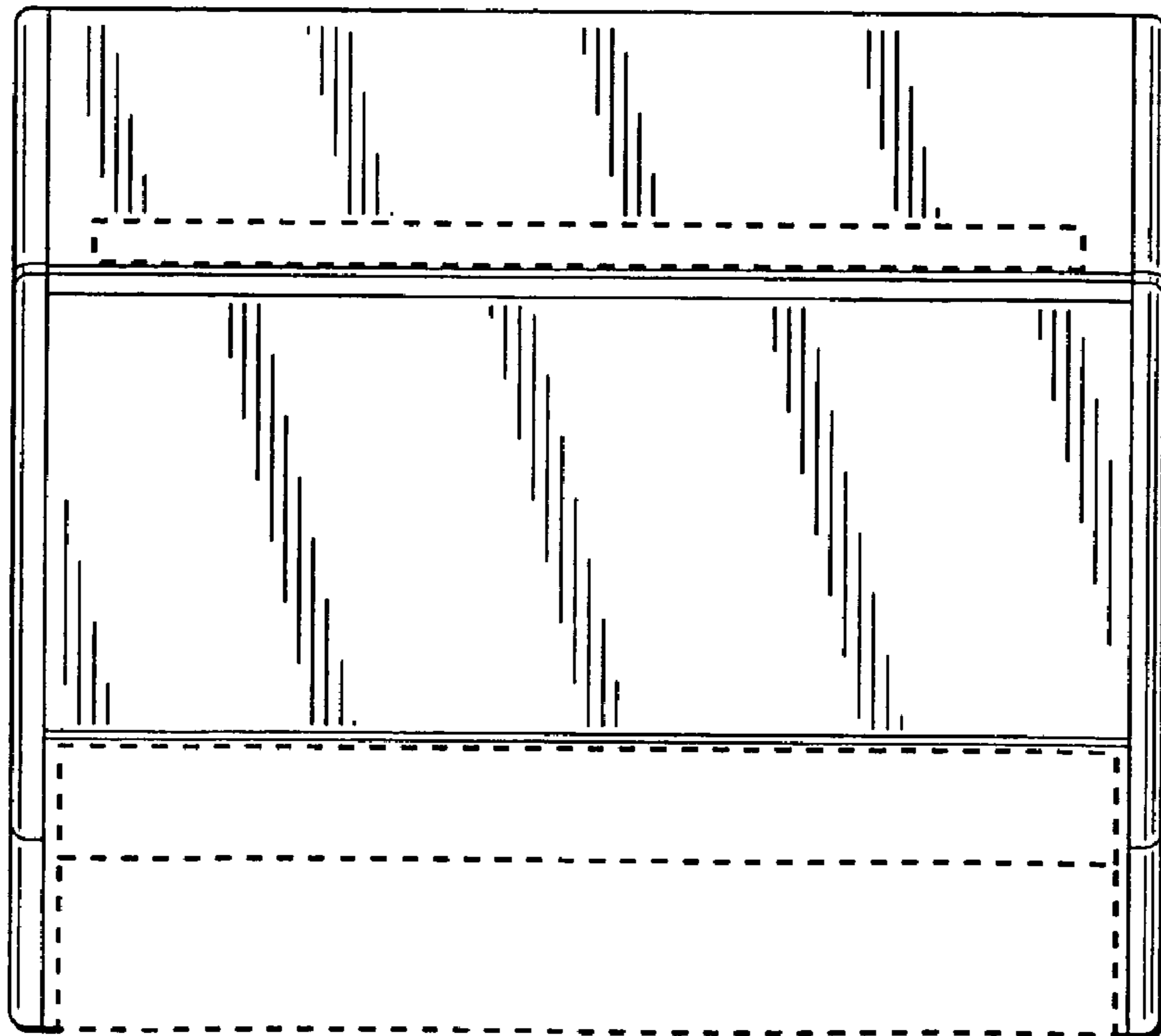
**FIG. 9**



**FIG. 10**



**FIG. 11**



**FIG. 12**