

US00D547656S

(12) **United States Design Patent** (10) **Patent No.:** **US D547,656 S**  
**van der Heijden et al.** (45) **Date of Patent:** **\*\* Jul. 31, 2007**

(54) **DISPENSER FOR LIQUID SOAP** D463,743 S 10/2002 de Mourgues  
D466,812 S 12/2002 Yang

(75) Inventors: **Edgar van der Heijden**, Broek op Langedijk (NL); **Peter Jozef Jan Albertz**, Haarlem (NL)

(Continued)

**FOREIGN PATENT DOCUMENTS**

(73) Assignee: **Airspray International B.V.**, Alkmaar (NL) JP 9118352 5/1997  
JP 9124063 5/1997  
JP 9183451 7/1997  
(\*\*) Term: **14 Years** JP 2004121889 4/2004  
JP 2004217283 8/2004  
(21) Appl. No.: **29/272,591** JP 2004218556 8/2004

**OTHER PUBLICATIONS**

Brochure for GCI—Global Cosmetic Industry, “Branding: Powerful Protection Against Competition and Insulation from Changing Economic Conditions,” Apr. 2002.

(Continued)

*Primary Examiner*—Robert M. Spear  
*Assistant Examiner*—Susan Bennett Hattan  
(74) *Attorney, Agent, or Firm*—Hoffmann & Baron, LLP

(22) Filed: **Feb. 12, 2007**

**Related U.S. Application Data**

(60) Continuation of application No. 29/264,791, filed on Aug. 17, 2006, now Pat. No. Des. 536,972, which is a division of application No. 29/251,258, filed on Jan. 5, 2006, now Pat. No. Des. 529,384.

(30) **Foreign Application Priority Data**

Jul. 5, 2005 (EM) ..... 000368097-0001

(51) **LOC (8) Cl.** ..... **09-07**

(52) **U.S. Cl.** ..... **D9/448; D9/434**

(58) **Field of Classification Search** ..... D9/694,  
D9/693, 682, 529, 448, 447, 440, 435, 686,  
D9/575, 552, 549, 516; D7/587, 558, 555,  
D7/554.4, 554.2, 553.6, 553.1, 550.1; D6/550,  
D6/542, 536; D23/254, 250, 249; 222/562,  
222/402.13, 402.1, 385, 383.1, 372, 321.7,  
222/321.3, 320, 153.13

See application file for complete search history.

(56) **References Cited**

**U.S. PATENT DOCUMENTS**

D272,988 S 3/1984 Podall et al.  
D320,348 S 10/1991 Law  
5,615,806 A 4/1997 Grothoff  
D398,529 S 9/1998 Mascitelli  
D452,822 S 1/2002 Boshuizen et al.

(57) **CLAIM**

The ornamental design for a dispenser for liquid soap, as shown and described.

**DESCRIPTION**

FIG. 1 is a perspective view of a dispenser for liquid soap showing our new design;

FIG. 2 is a front elevation view thereof;

FIG. 3 is a side elevation view thereof;

FIG. 4 is a rear elevation view thereof; and,

FIG. 5 is a top view thereof.

The subject matter shown in broken lines is for illustrative purposes only and forms no part of the claimed design. The bottom view (not shown) forms no part of the claimed design.

**1 Claim, 5 Drawing Sheets**

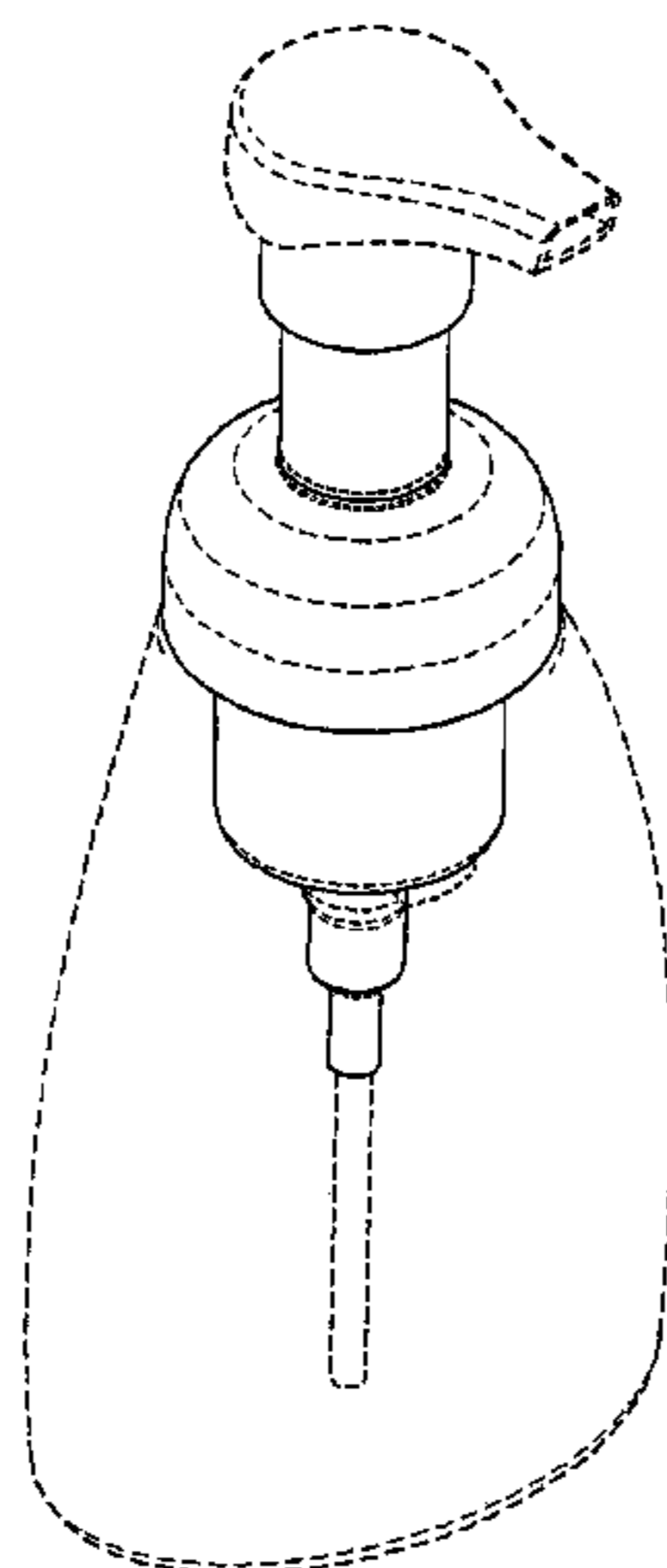

# US D547,656 S

Page 2

---

## U.S. PATENT DOCUMENTS

D470,043 S 2/2003 Crawford  
D471,105 S 3/2003 González Fernández  
D480,642 S 10/2003 Dretzka  
D480,643 S 10/2003 Dretzka  
D484,402 S \* 12/2003 Crawford ..... D9/693  
D484,403 S \* 12/2003 Crawford ..... D9/682  
D485,747 S \* 1/2004 Crawford ..... D9/682  
D488,716 S 4/2004 Dretzka  
D499,333 S \* 12/2004 Crawford ..... D9/694  
D499,966 S 12/2004 Arminak

6,840,408 B1 1/2005 Foster et al.  
D507,486 S \* 7/2005 Wang ..... D9/448  
D524,166 S \* 7/2006 Walther et al. .... D9/682

## OTHER PUBLICATIONS

Marchie, Melanie, "A New Attitude: Soaps Get Serious," a brochure reprinted from the Dec. 2001 issue of Happi.  
Brochure for Rieke Packaging Systems, "Fully Integrated Response to Your Global Packaging Needs," on dispensers.

\* cited by examiner

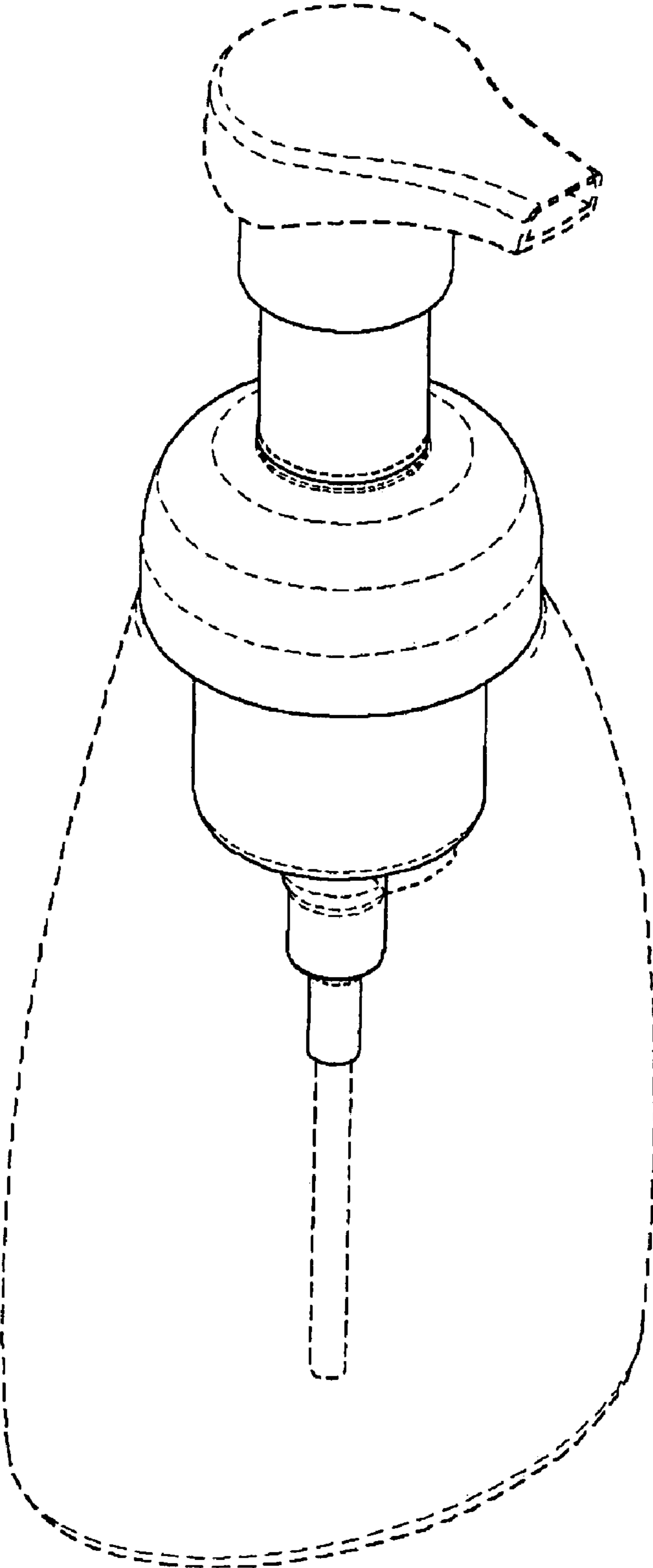

Fig. 1

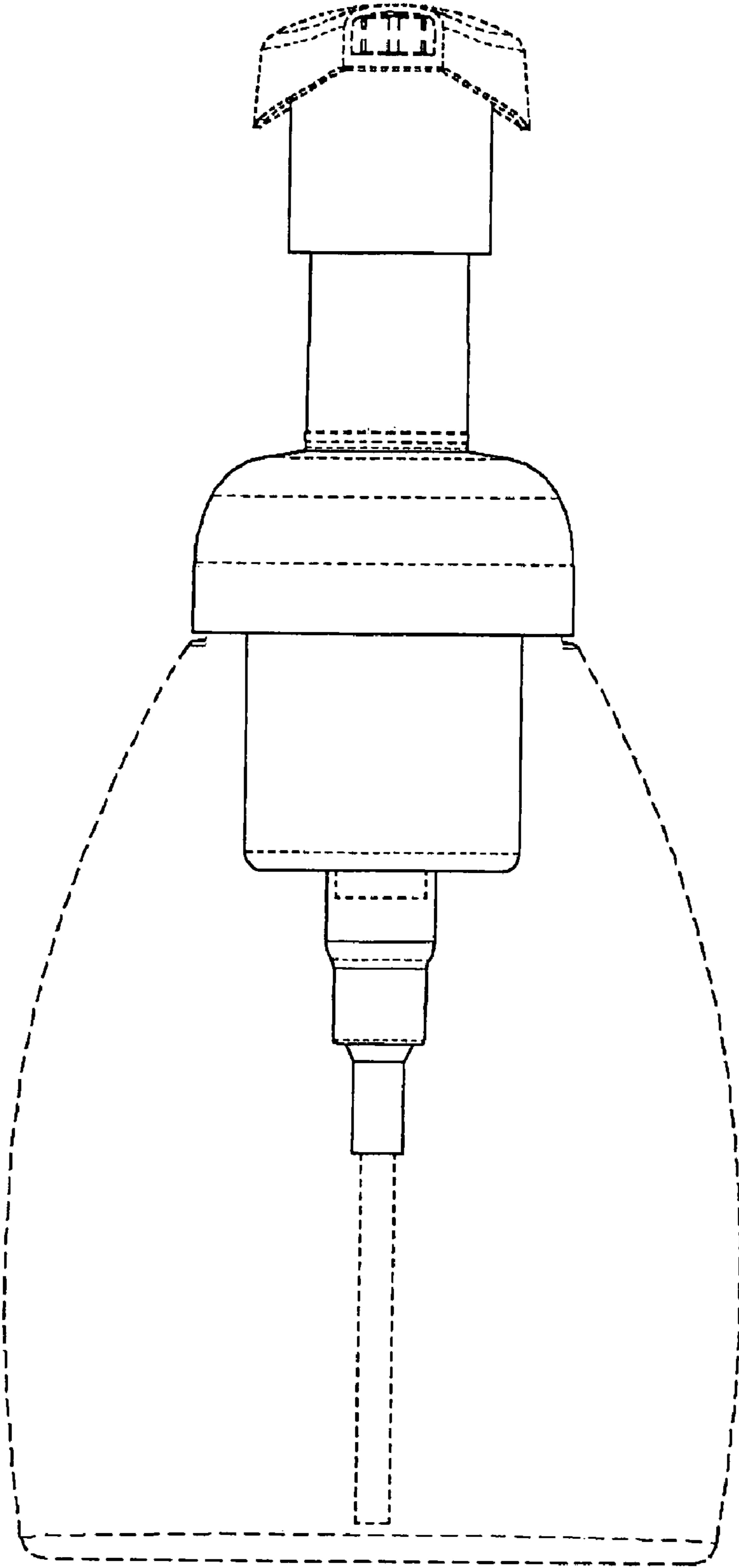

Fig. 2

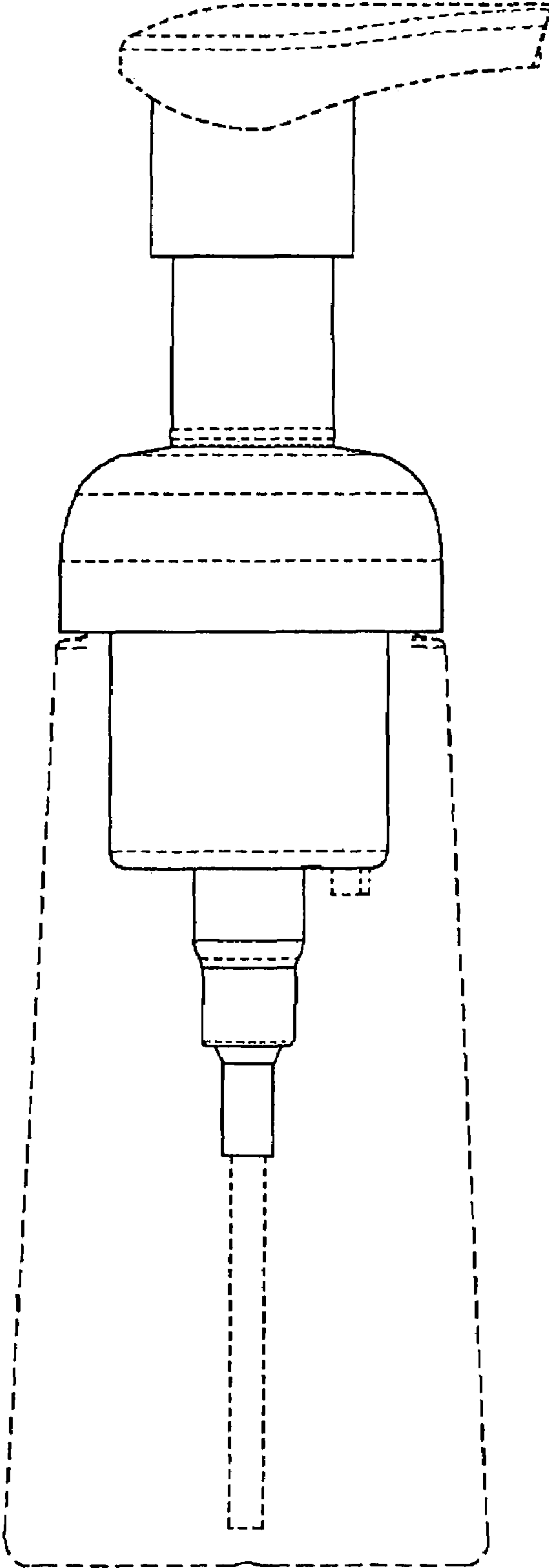

Fig. 3

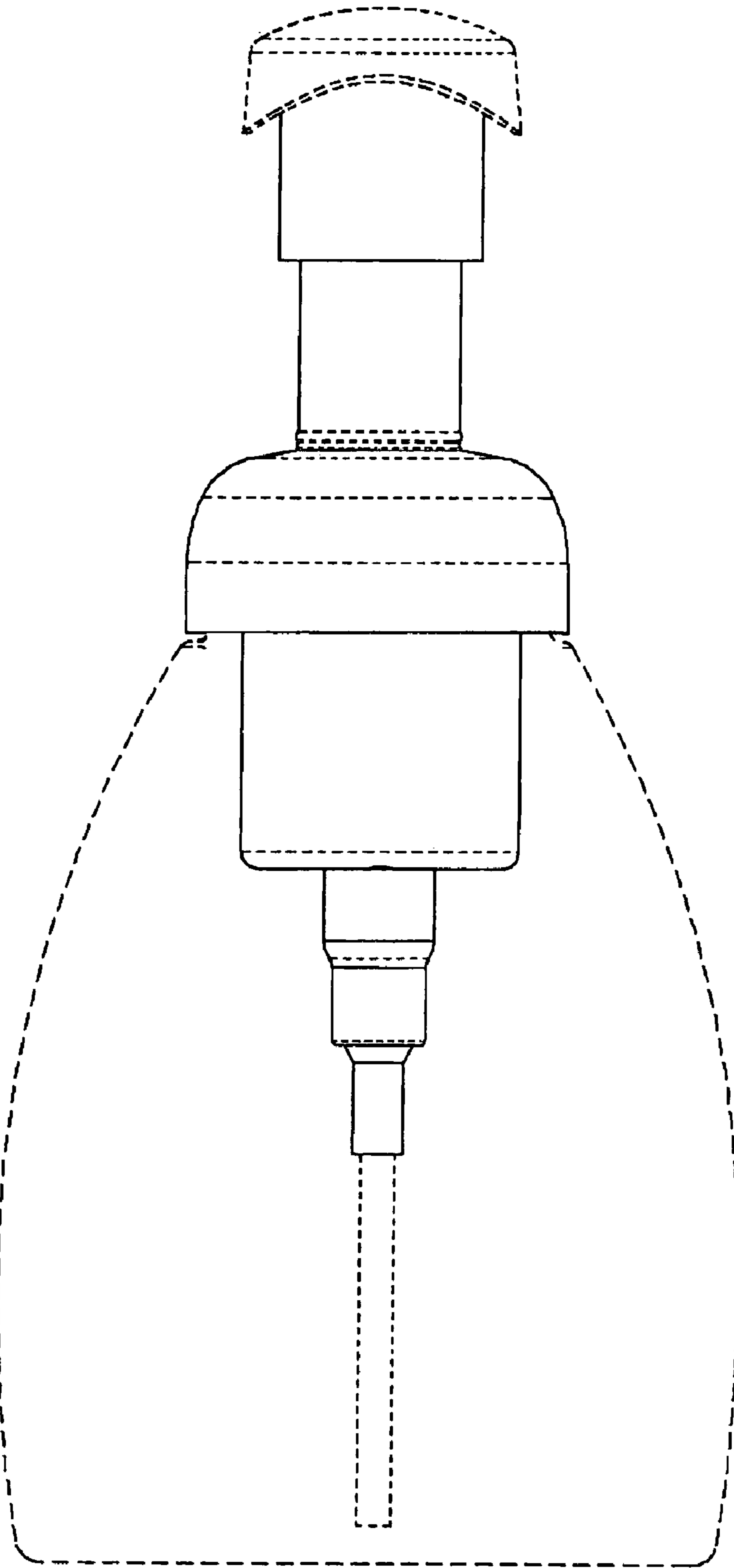

Fig. 4

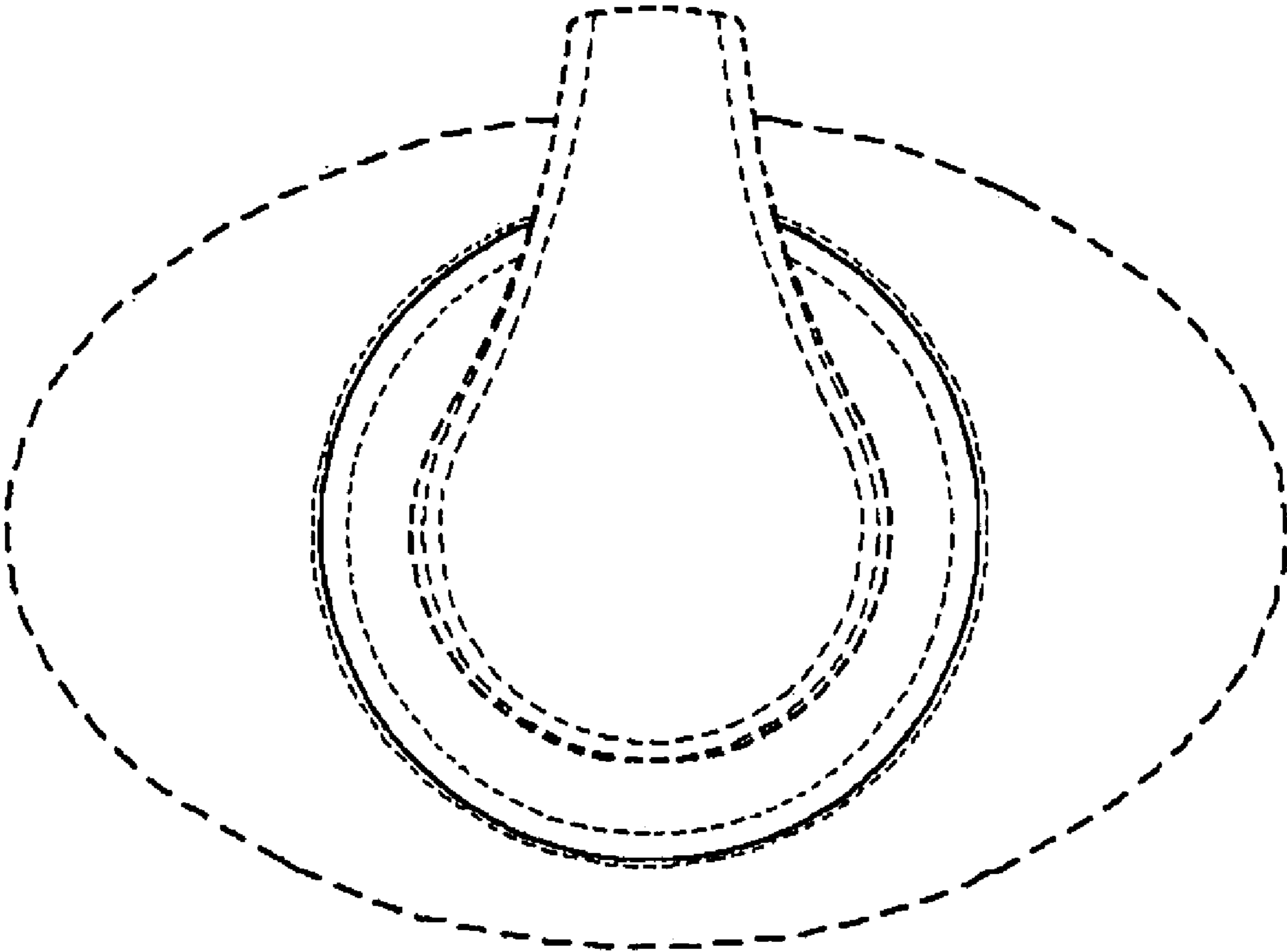

Fig. 5