



US00D547093S

(12) **United States Design Patent**  
**Butters**

(10) **Patent No.:** **US D547,093 S**

(45) **Date of Patent:** **\*\* Jul. 24, 2007**

(54) **COLLAPSIBLE SHELF UNIT**

D463,697 S \* 10/2002 Klein et al. .... D6/514  
D485,092 S \* 1/2004 Rosen ..... D6/465

(76) Inventor: **Mary Jane Butters**, 1000 Wild Iris La.,  
Moscow, ID (US) 83843

\* cited by examiner

(\*\*) Term: **14 Years**

*Primary Examiner*—Robert M. Spear  
*Assistant Examiner*—Mary Ann Calabrese

(21) Appl. No.: **29/203,558**

(74) *Attorney, Agent, or Firm*—Duncan Palmatier

(22) Filed: **Apr. 14, 2004**

(57) **CLAIM**

(51) **LOC (8) Cl.** ..... **06-04**

I claim the ornamental design for a collapsible shelf unit, as shown and described.

(52) **U.S. Cl.** ..... **D6/462**

(58) **Field of Classification Search** ..... D6/396,  
D6/405, 429, 458, 449, 462–465, 473–476,  
D6/514, 512; 211/11, 13.1, 48, 50, 85, 85.31,  
211/118, 149, 181.1, 186; 108/76, 162, 163;  
119/60; 126/9 R

**DESCRIPTION**

See application file for complete search history.

FIG. 1 is a perspective view of a collapsible shelf unit showing the ornamental design of the invention.

FIG. 2 is a perspective view from the front of the ornamental design of the collapsible shelf unit of the invention.

(56) **References Cited**

**U.S. PATENT DOCUMENTS**

FIG. 3 is a perspective view from the back of the ornamental design of the collapsible shelf unit of the invention.

719,060	A *	1/1903	Thomas	.....	108/76
1,039,694	A *	10/1912	Burton	.....	108/163
D104,568	S *	5/1937	Griffin	.....	D6/464
2,518,549	A *	8/1950	Hyde	.....	119/60
3,235,096	A *	2/1966	Hallock et al.	.....	211/149
4,191,160	A *	3/1980	Elliott	.....	126/9 R
4,759,450	A *	7/1988	Ball et al.	.....	211/50
4,858,773	A *	8/1989	Zimmerman	.....	211/149
D319,356	S *	8/1991	Vukelich, Sr.	.....	D6/405
D368,186	S *	3/1996	Tiemann	.....	D6/465

FIG. 4 is a side elevational view from the right side of the ornamental design of the collapsible shelf unit of the invention. The left side is a mirror image of the FIG. 4.

FIG. 5 is a top plan view of the ornamental design of the collapsible shelf unit of the invention; and,

FIG. 6 is a bottom plan view of the ornamental design of the collapsible shelf unit of the invention.

**1 Claim, 5 Drawing Sheets**

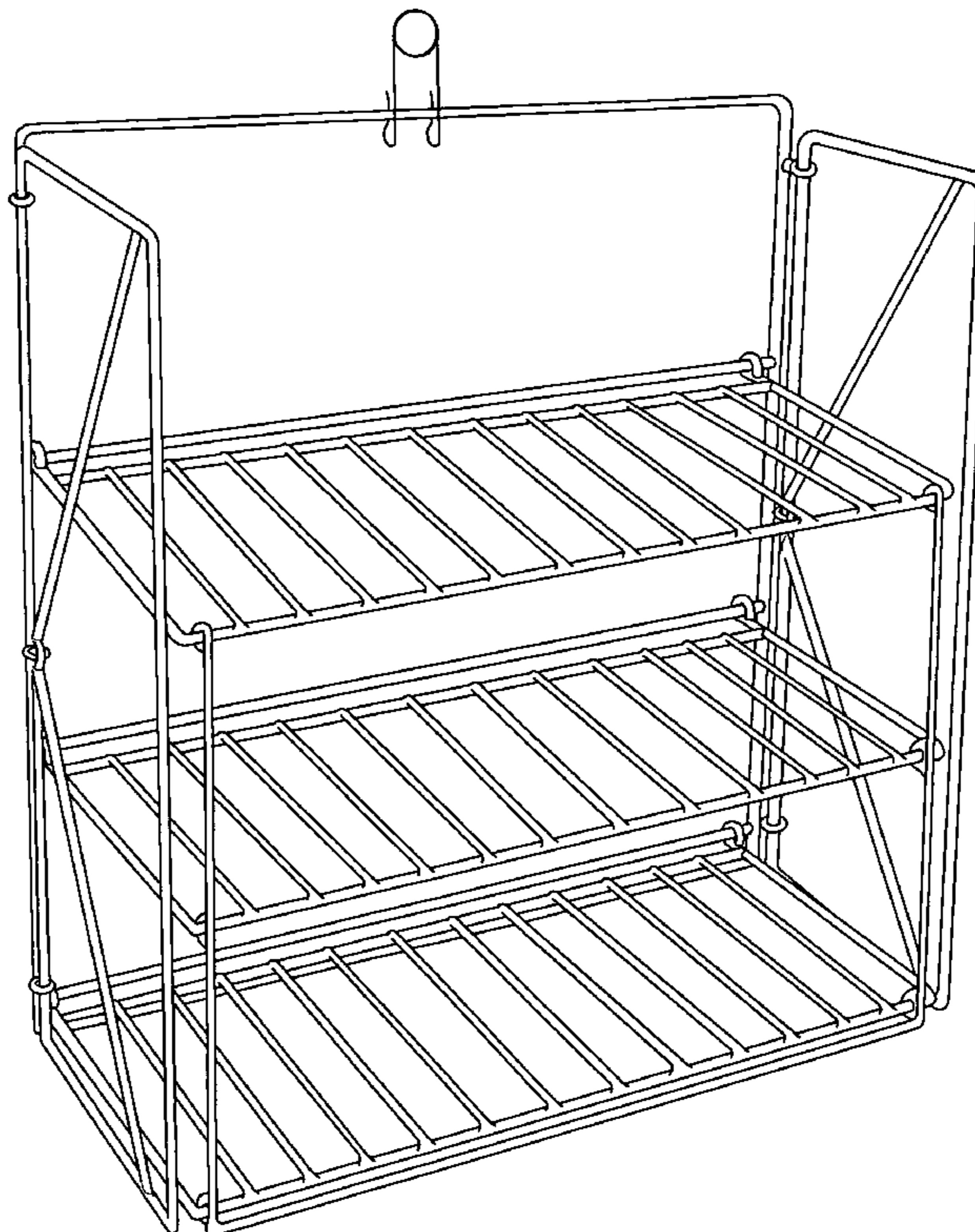

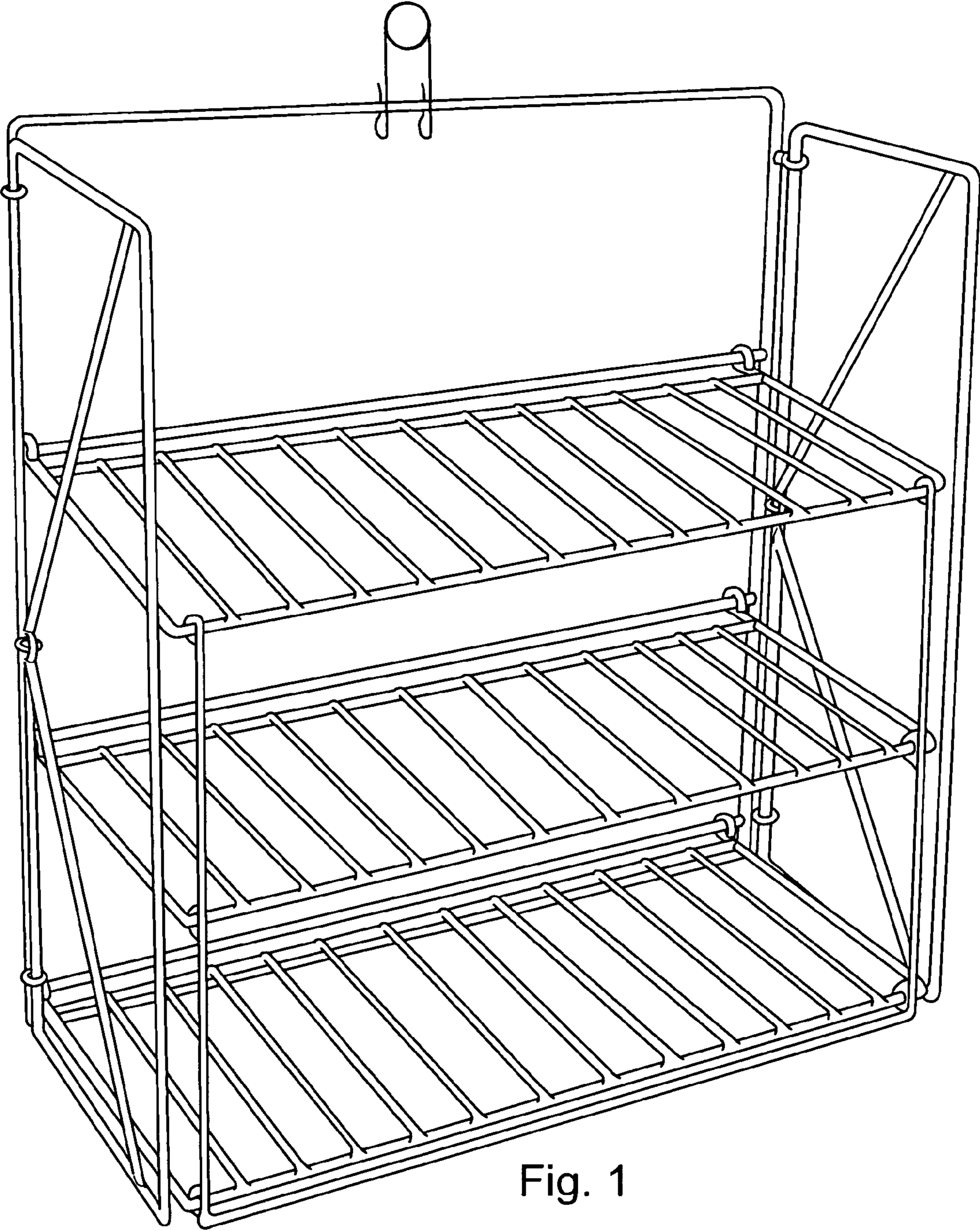

Fig. 1

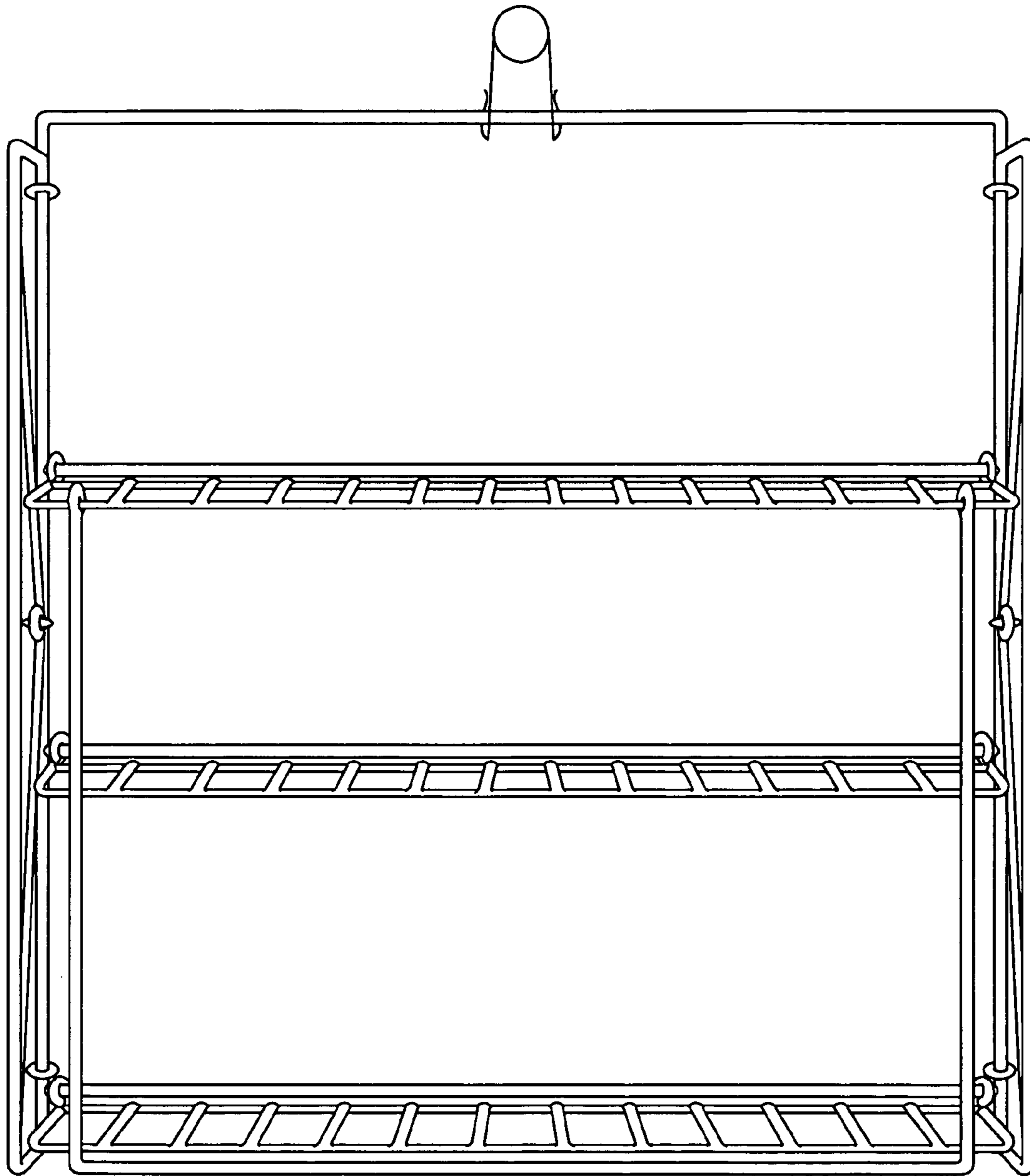

Fig. 2

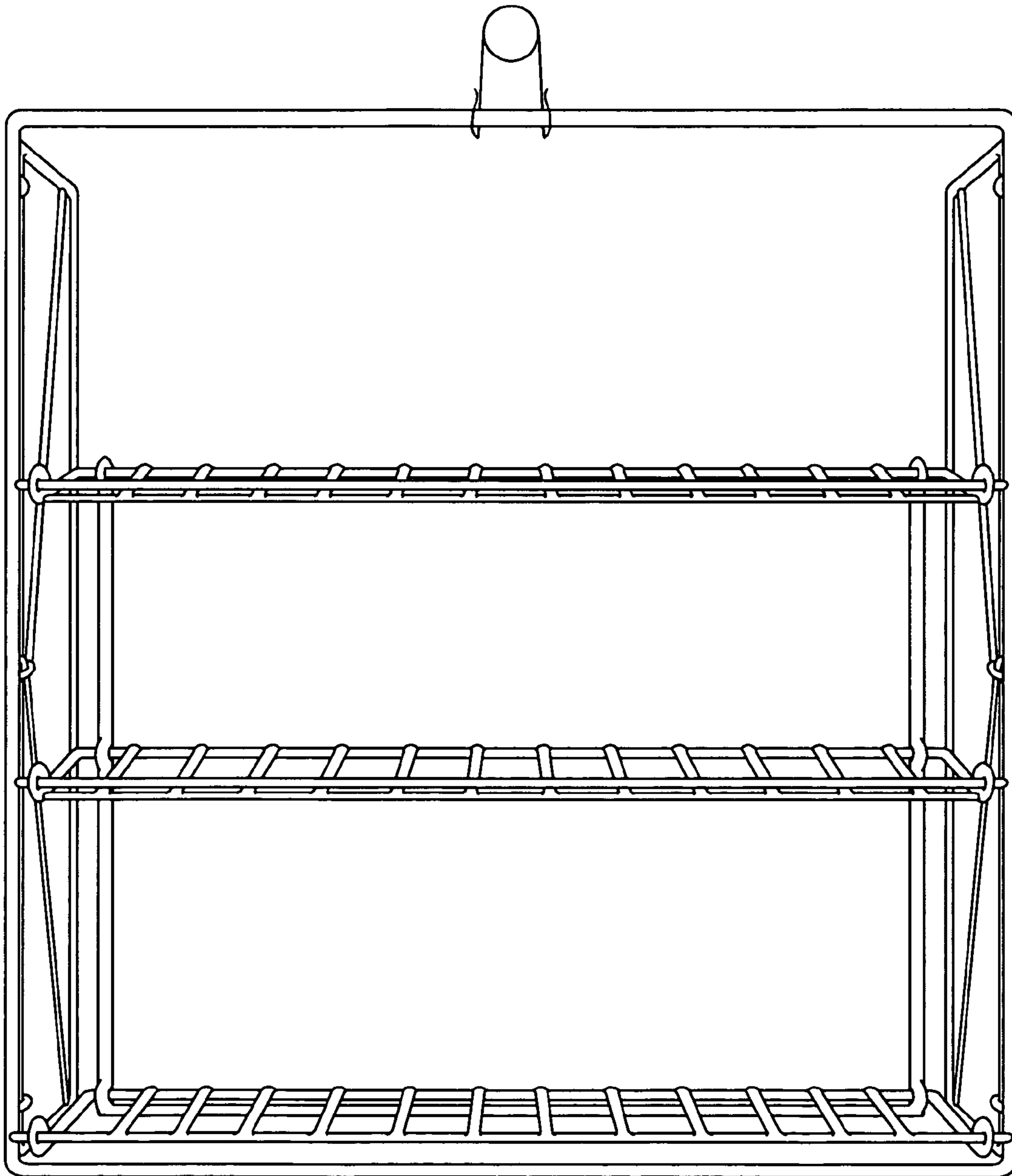

Fig. 3

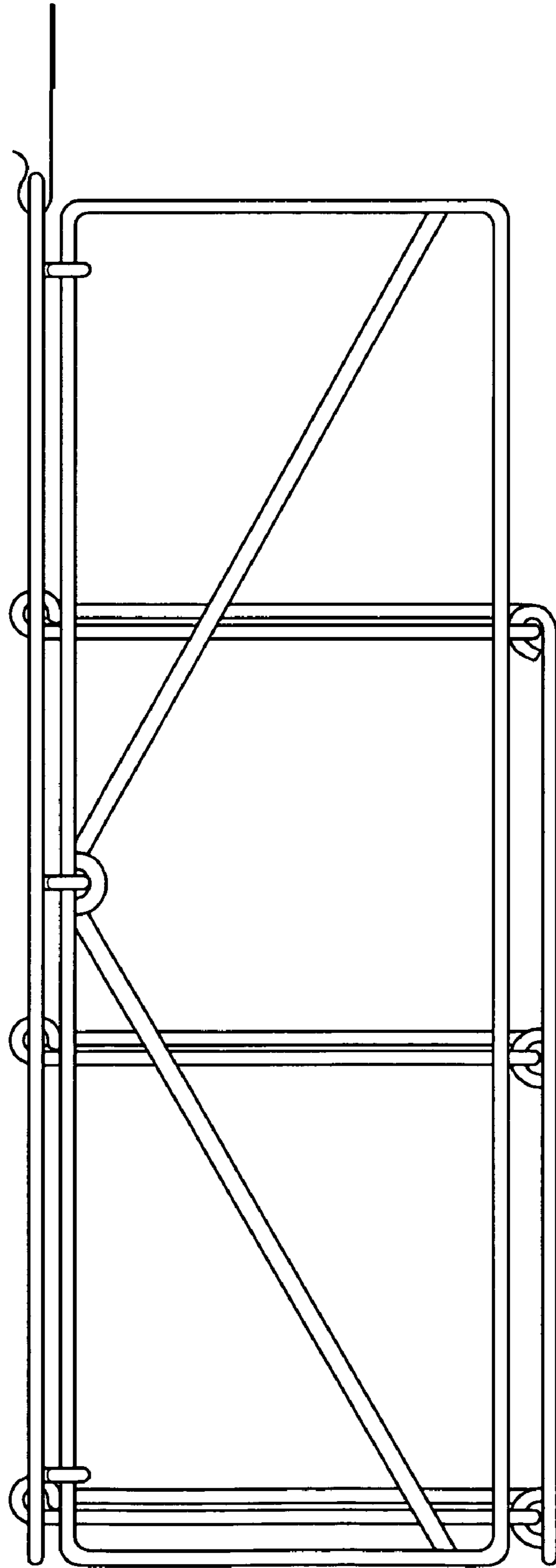

Fig. 4

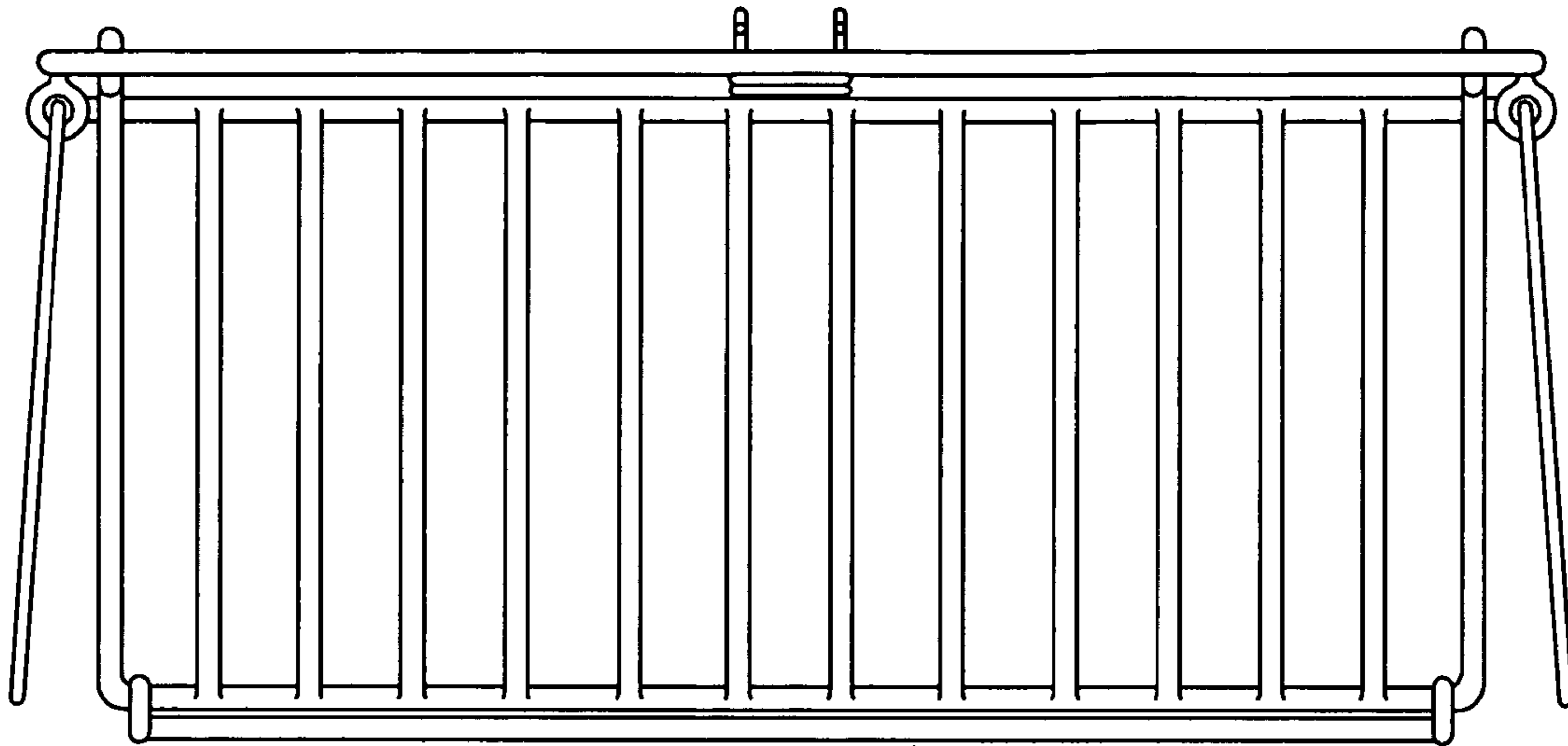

Fig. 5

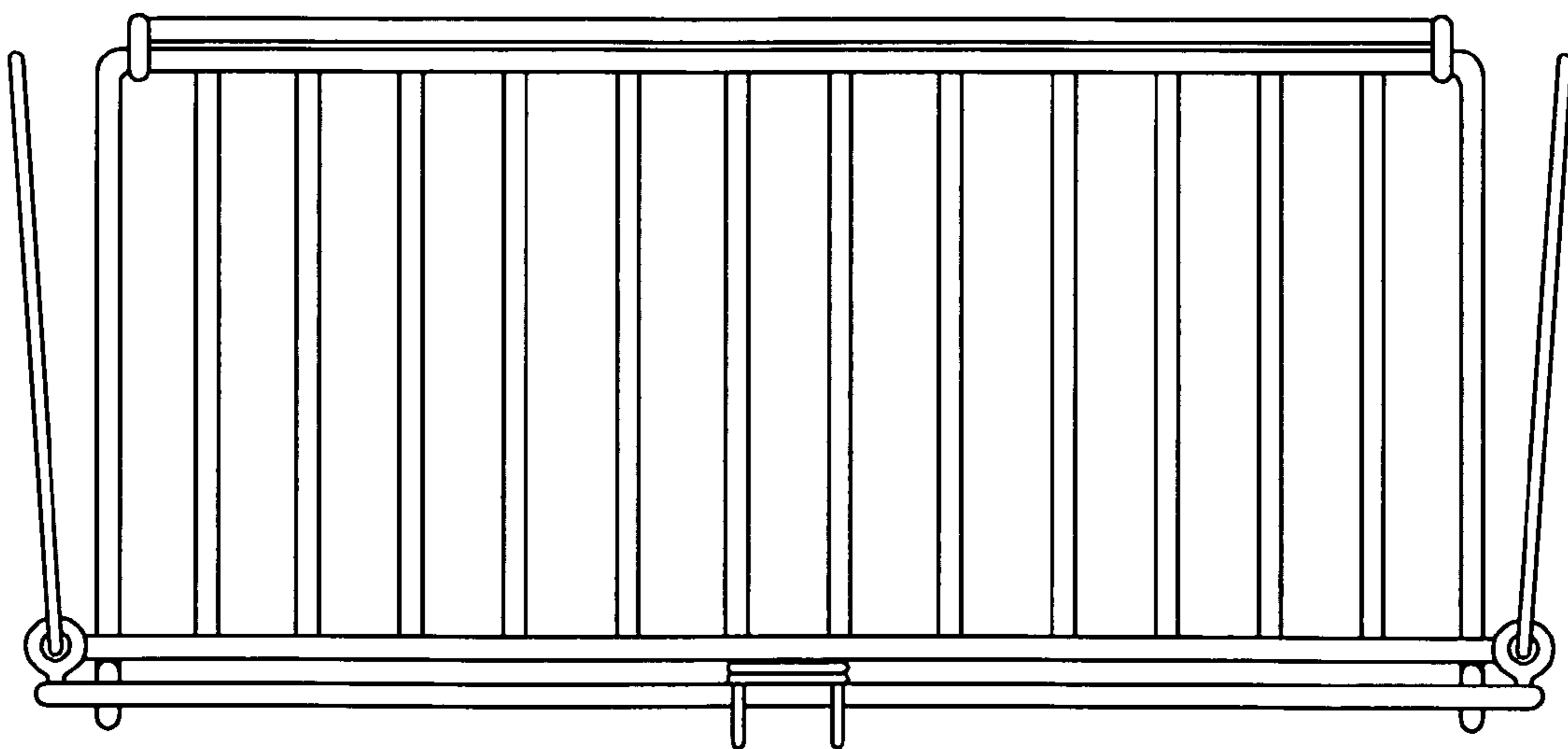

Fig. 6