



US00D546732S

(12) **United States Design Patent**  
**Chuang**

(10) **Patent No.:** **US D546,732 S**

(45) **Date of Patent:** **\*\* Jul. 17, 2007**

(54) **MOTORCYCLE**

D490,750 S \* 6/2004 Hoshino ..... D12/110  
D514,987 S \* 2/2006 Hsiao ..... D12/110

(75) Inventor: **Chien-Hung Chuang**, Hsinchu County (TW)

(73) Assignee: **Sanyang Industry Co., Ltd.**, Hsinchu County (TW)

(\*\*) Term: **14 Years**

(21) Appl. No.: **29/262,191**

(22) Filed: **Jun. 28, 2006**

(30) **Foreign Application Priority Data**

Mar. 6, 2006 (TW) ..... 95301107

(51) **LOC (8) Cl.** ..... **12-11**

(52) **U.S. Cl.** ..... **D12/110**

(58) **Field of Classification Search** ..... D12/110;  
180/219, 220, 225, 229

See application file for complete search history.

(56) **References Cited**

**U.S. PATENT DOCUMENTS**

D299,632 S \* 1/1989 Ito et al. .... D12/110

\* cited by examiner

*Primary Examiner*—Alan P. Douglas

*Assistant Examiner*—Linda Brooks

(74) *Attorney, Agent, or Firm*—Quintero Law Office

(57) **CLAIM**

The ornamental design for a motorcycle, as shown and described.

**DESCRIPTION**

FIG. 1 is a front perspective view thereof;

FIG. 2 is a front elevational view thereof;

FIG. 3 is a rear elevational view thereof;

FIG. 4 is a right side elevational view thereof;

FIG. 5 is a left side elevational view thereof; and,

FIG. 6 is a top plane view thereof.

**1 Claim, 6 Drawing Sheets**

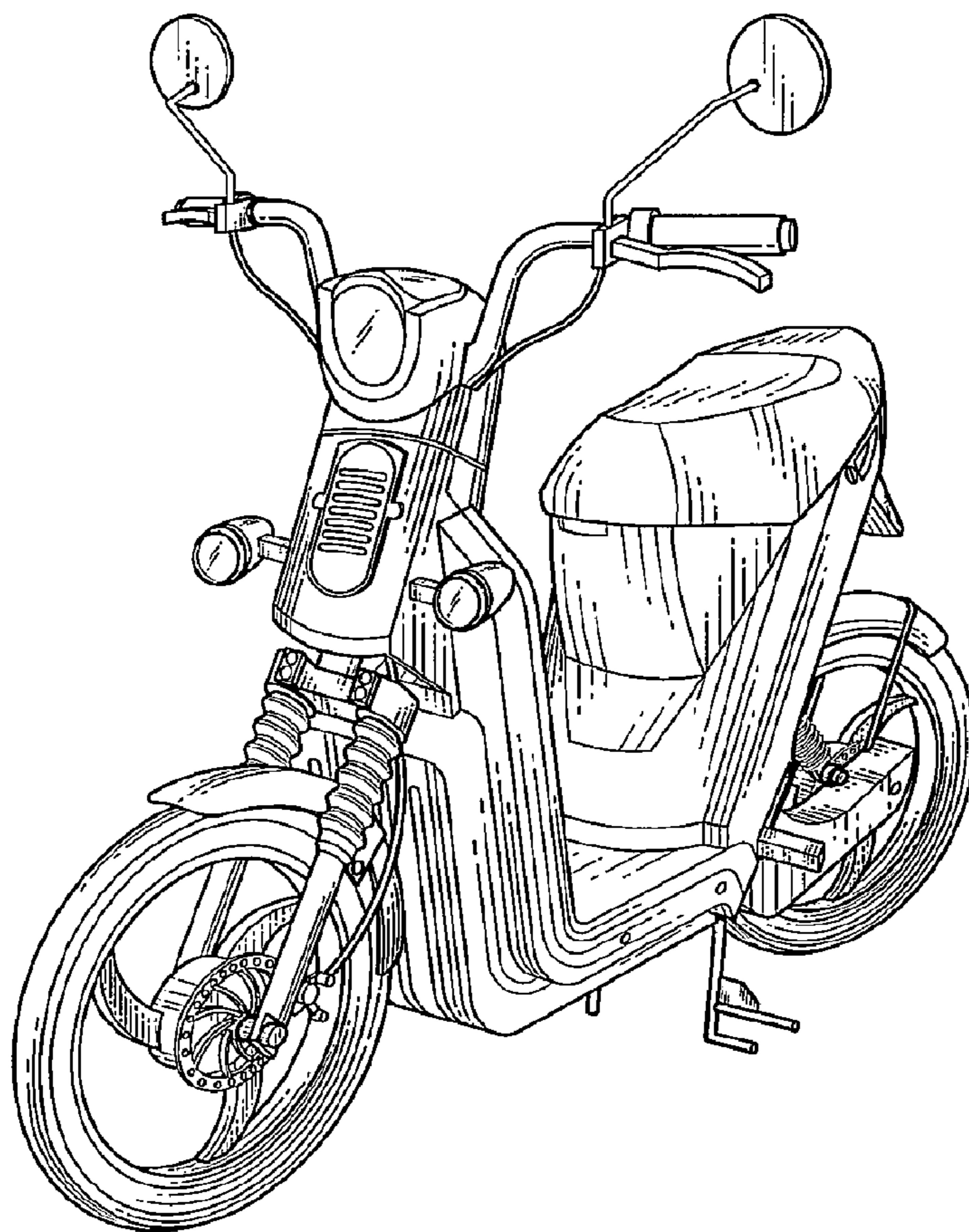

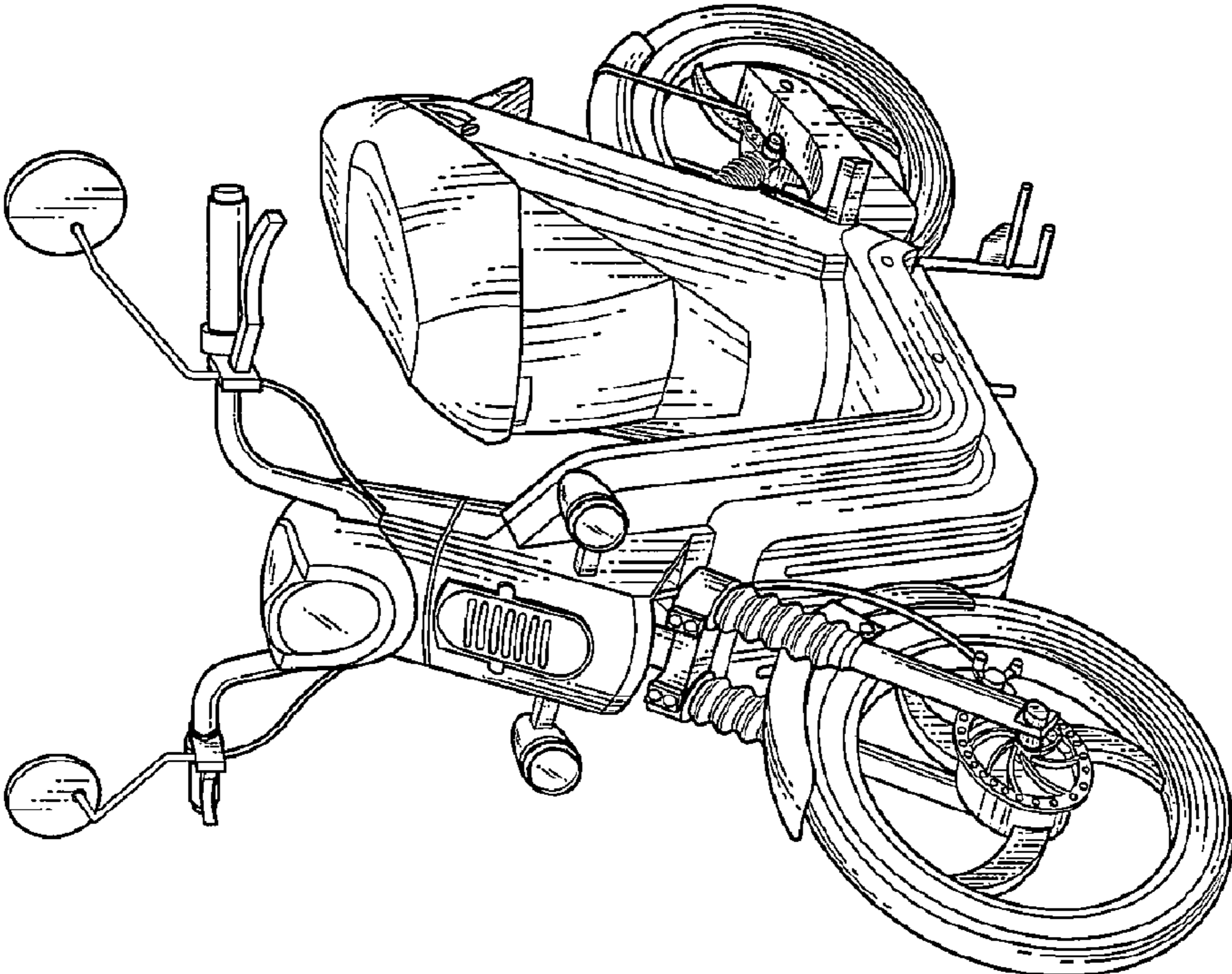

FIG. 1

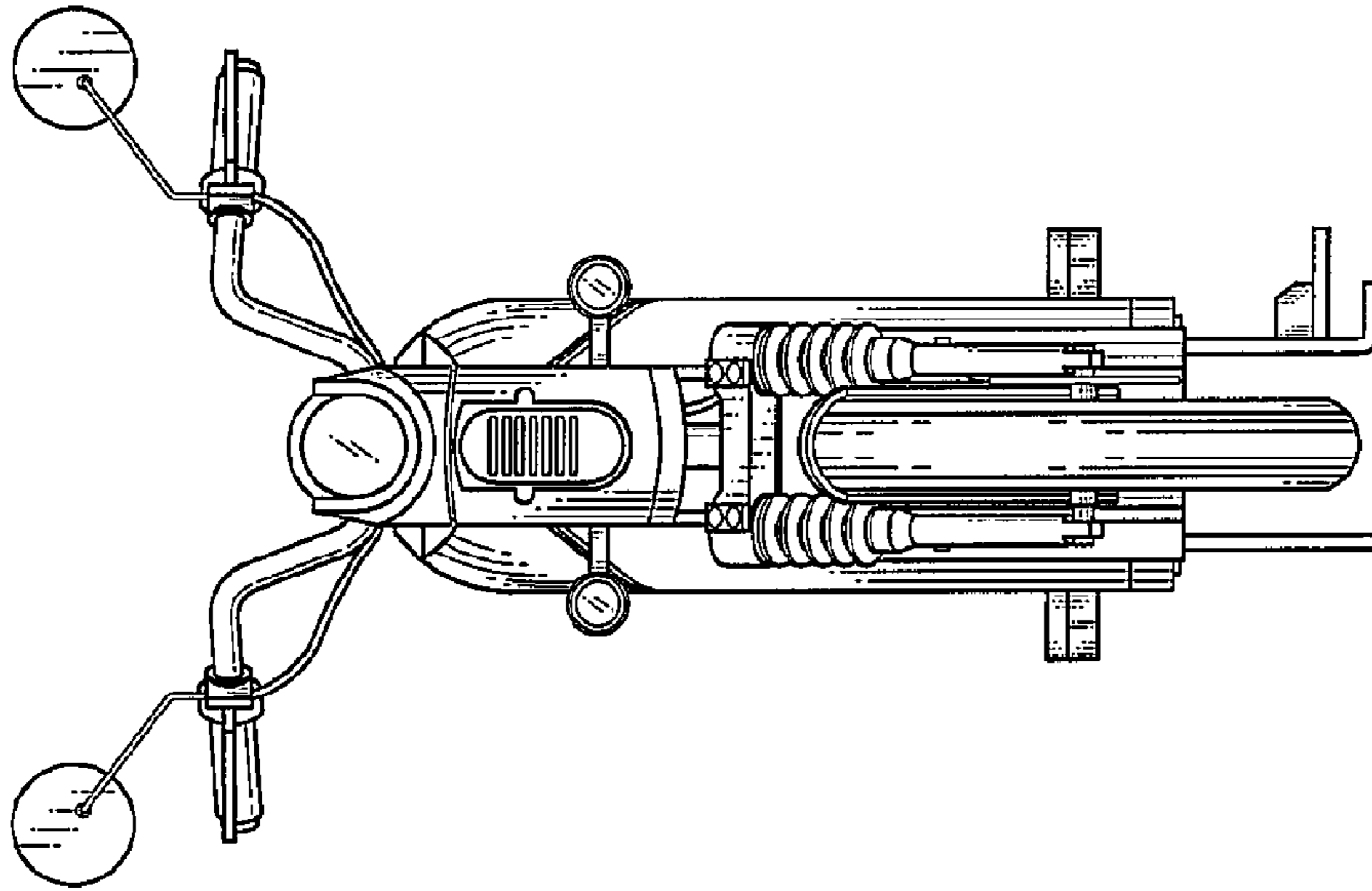

FIG. 2

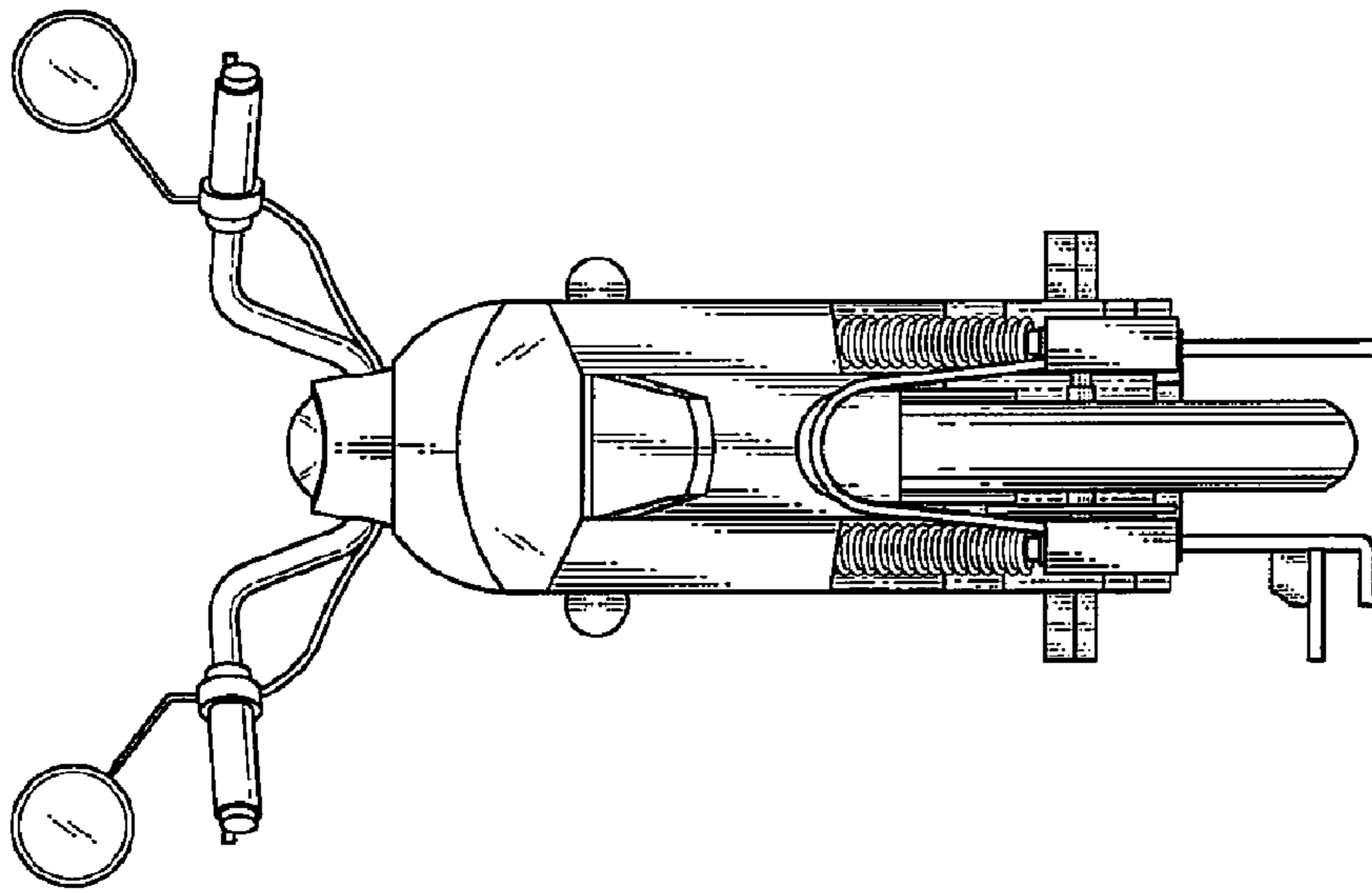

FIG. 3

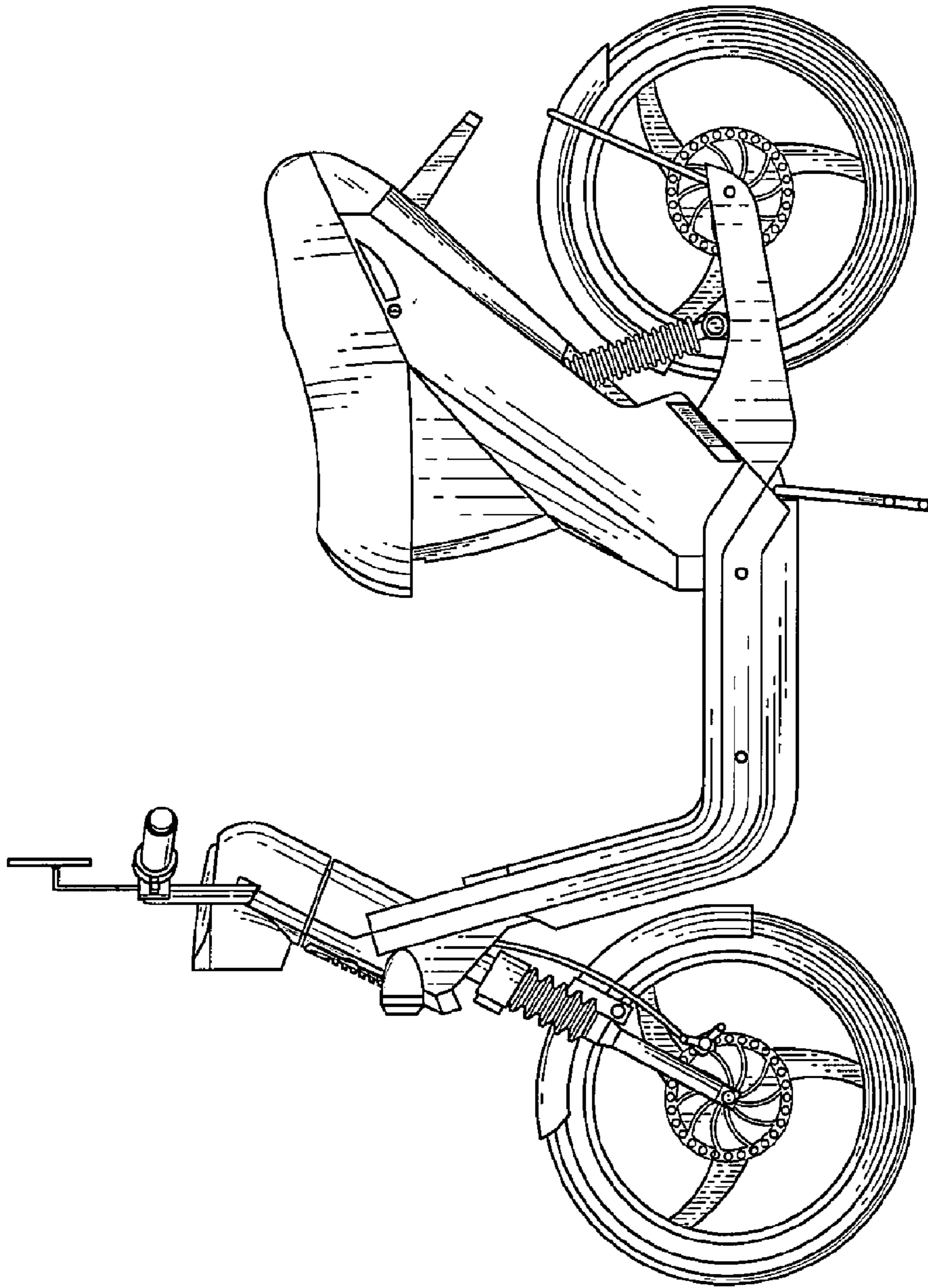

FIG. 4

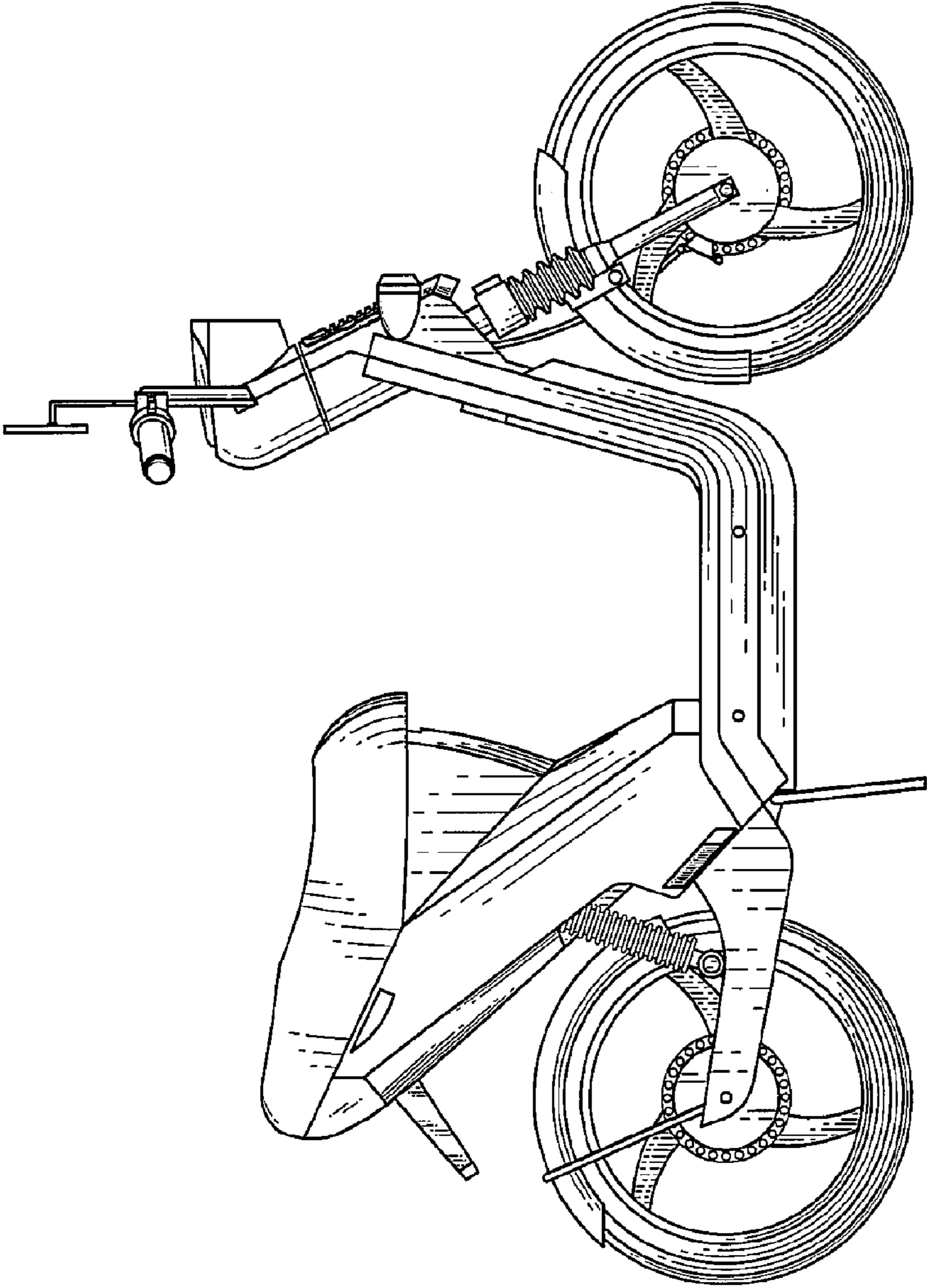

FIG. 5

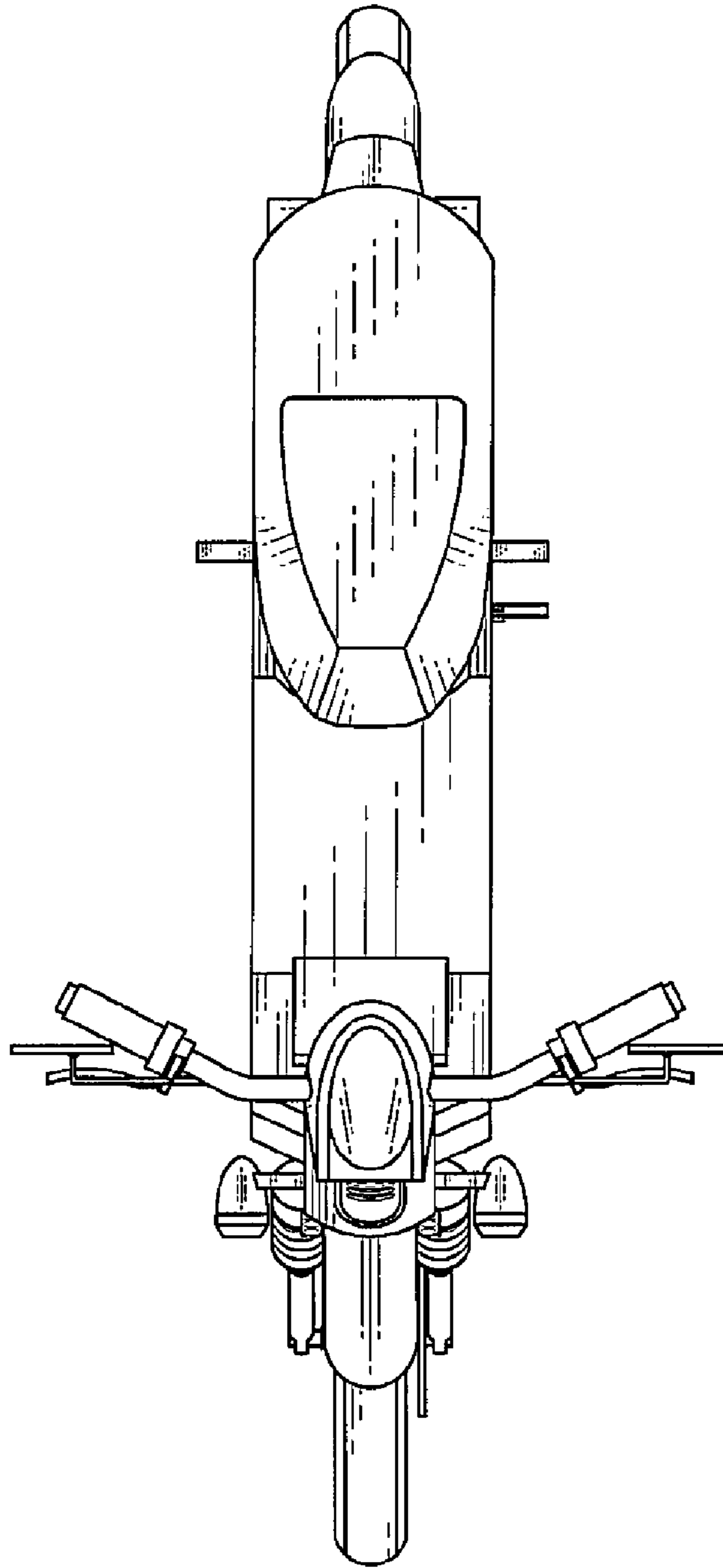

FIG. 6