

US00D546498S

(12) **United States Design Patent** (10) **Patent No.:** **US D546,498 S**
Ke (45) **Date of Patent:** **** Jul. 10, 2007**

(54) **PART OF A LIGHT FIXTURE**

2004/0151002 A1* 8/2004 Garber et al. 362/405

(76) Inventor: **Zhengguo Ke**, Room #1309, Winner
Way Hotel, Dong Guan City,
Guangdong (CN)

OTHER PUBLICATIONS

Co-pending U.S. Appl. No. 29/263,774, filed Jul. 28, 2006, Zheng-
guo Ke.
Co-pending U.S. Appl. No. 29/263,770, filed Jul. 28, 2006, Zheng-
guo Ke.
Minka Lavery, Corona, CA, Cat. 2003, vol. 7, p. 141 Model
A1199-56.
Designers Fountain, Rancho Dominguez, CA, Cat. 114, 2004 p. 58
Model 9099GF.
Tenth Ave Lighting, Co., Boerne, TX, Cat. 2005, p. 31 Model
20610-862 PF-SR.
Minka Lavery, Corona, CA, Cat. 2003 vol. 7, p. 105, Model
B986-84.

(**) Term: **14 Years**

* cited by examiner

(21) Appl. No.: **29/263,773**

(22) Filed: **Jul. 28, 2006**

(51) **LOC (8) Cl.** **26-99**

(52) **U.S. Cl.** **D26/155**

(58) **Field of Classification Search** D26/91,
D26/90, 88, 86, 85, 84, 81, 80, 72, 156, 155,
D26/154, 153, 149, 145, 144, 142, 138, 130,
D26/128, 118, 113, 143; 362/405, 227, 257,
362/404, 406

See application file for complete search history.

Primary Examiner—Freda S. Nunn
Assistant Examiner—Kevin K. Rudzinski

(56) **References Cited**

(57) **CLAIM**

U.S. PATENT DOCUMENTS

The ornamental design for a part of a light fixture, as shown
and described.

- D401,002 S * 11/1998 Keen D26/81
- D408,574 S * 4/1999 Milicia D26/81
- D413,177 S * 8/1999 Miranda D26/84
- D416,641 S * 11/1999 Palacios D26/81
- D430,689 S * 9/2000 Chiang D26/80
- D431,087 S * 9/2000 Dolan D26/81
- D433,172 S * 10/2000 Hsieh D26/86
- D438,664 S * 3/2001 Lewis D26/86
- D440,681 S * 4/2001 Dolan D26/84
- D441,892 S * 5/2001 Hsu D26/84
- D441,893 S * 5/2001 Dolan D26/84
- D446,336 S * 8/2001 Dolan D26/86
- D460,836 S * 7/2002 Swanson D26/86
- D480,495 S * 10/2003 Brunner D26/84
- D482,483 S * 11/2003 Brunner D26/81

DESCRIPTION

FIG. 1 is a perspective view thereof;
FIG. 2 is a front elevational view thereof;
FIG. 3 is a right side view,
FIG. 4 is a left side view thereof;
FIG. 5 is a top view thereof; and,
FIG. 6 is a bottom view thereof.

The broken lines showing environmental structure in FIGS.
1-6 are for illustrative purposes only and form no part of the
claimed design.

1 Claim, 6 Drawing Sheets

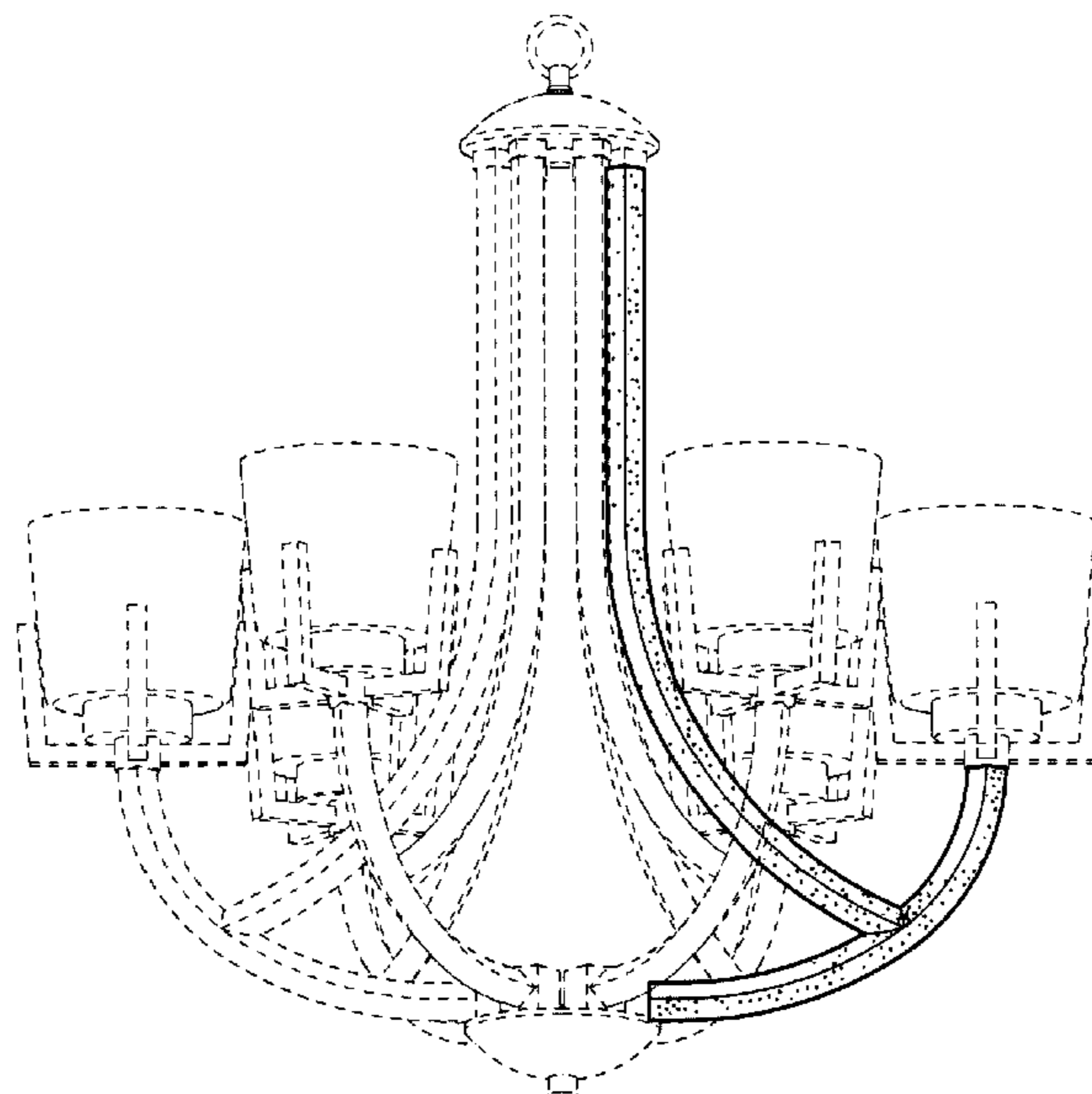

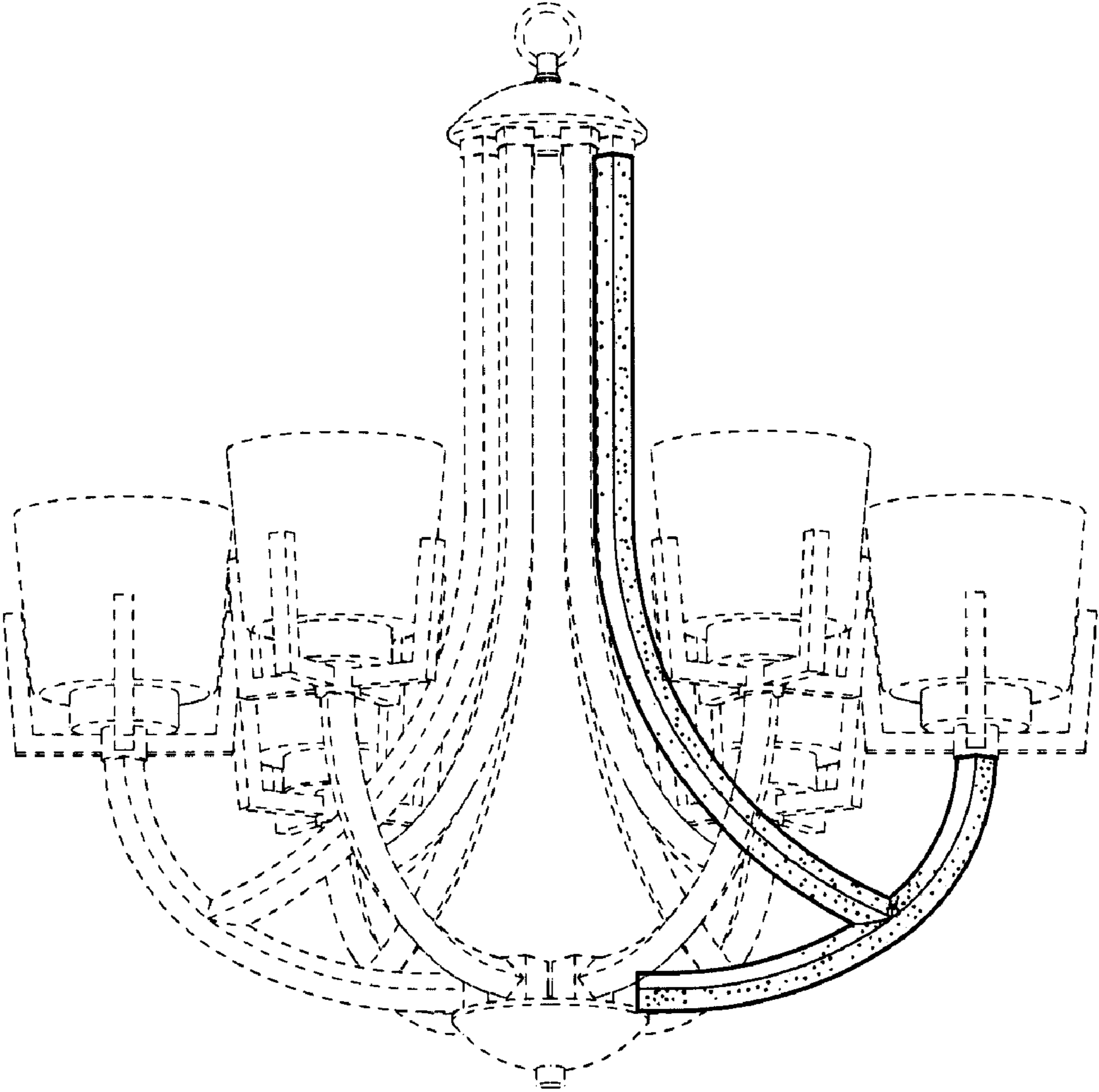

FIG. 1

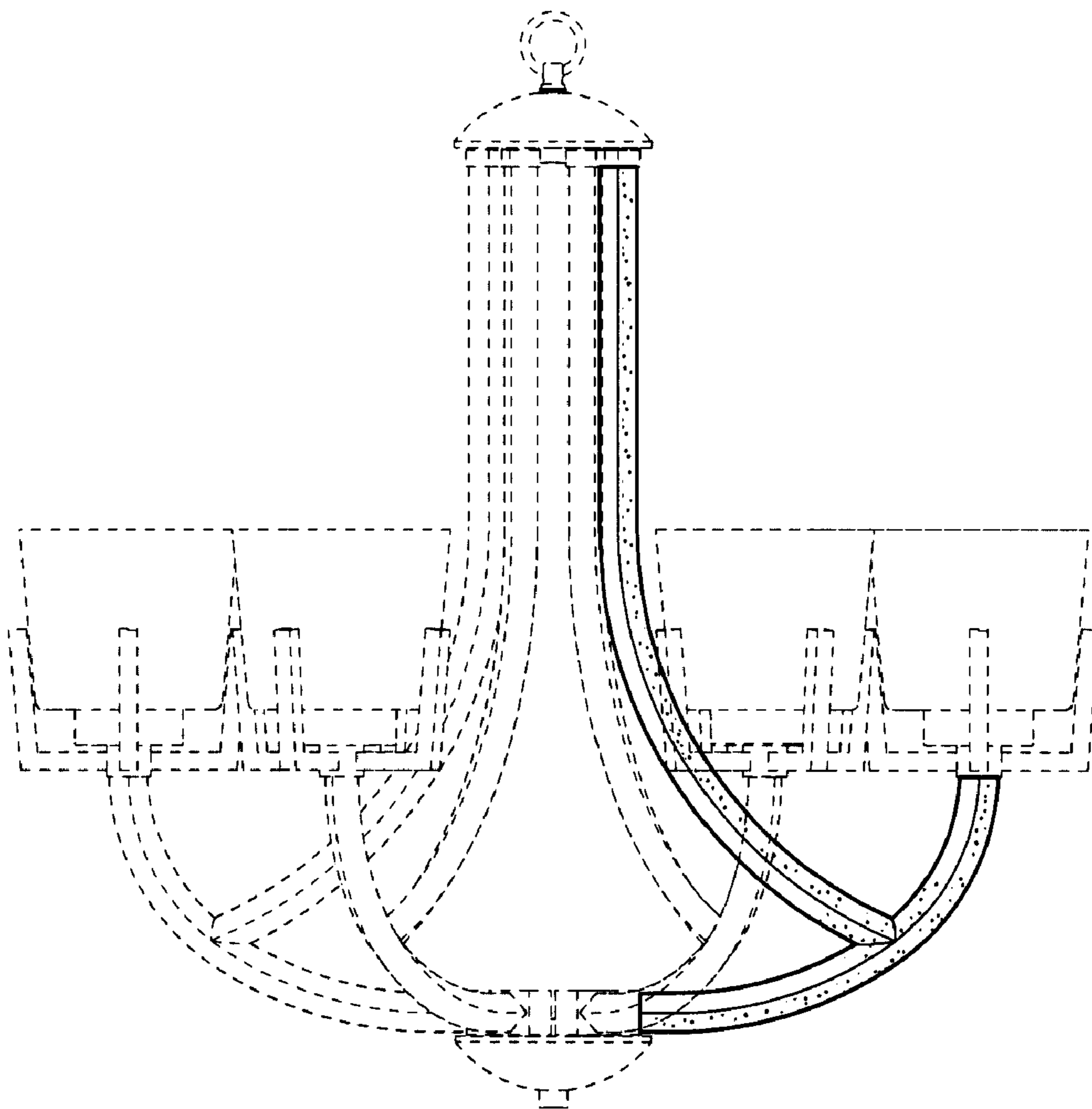

FIG. 2

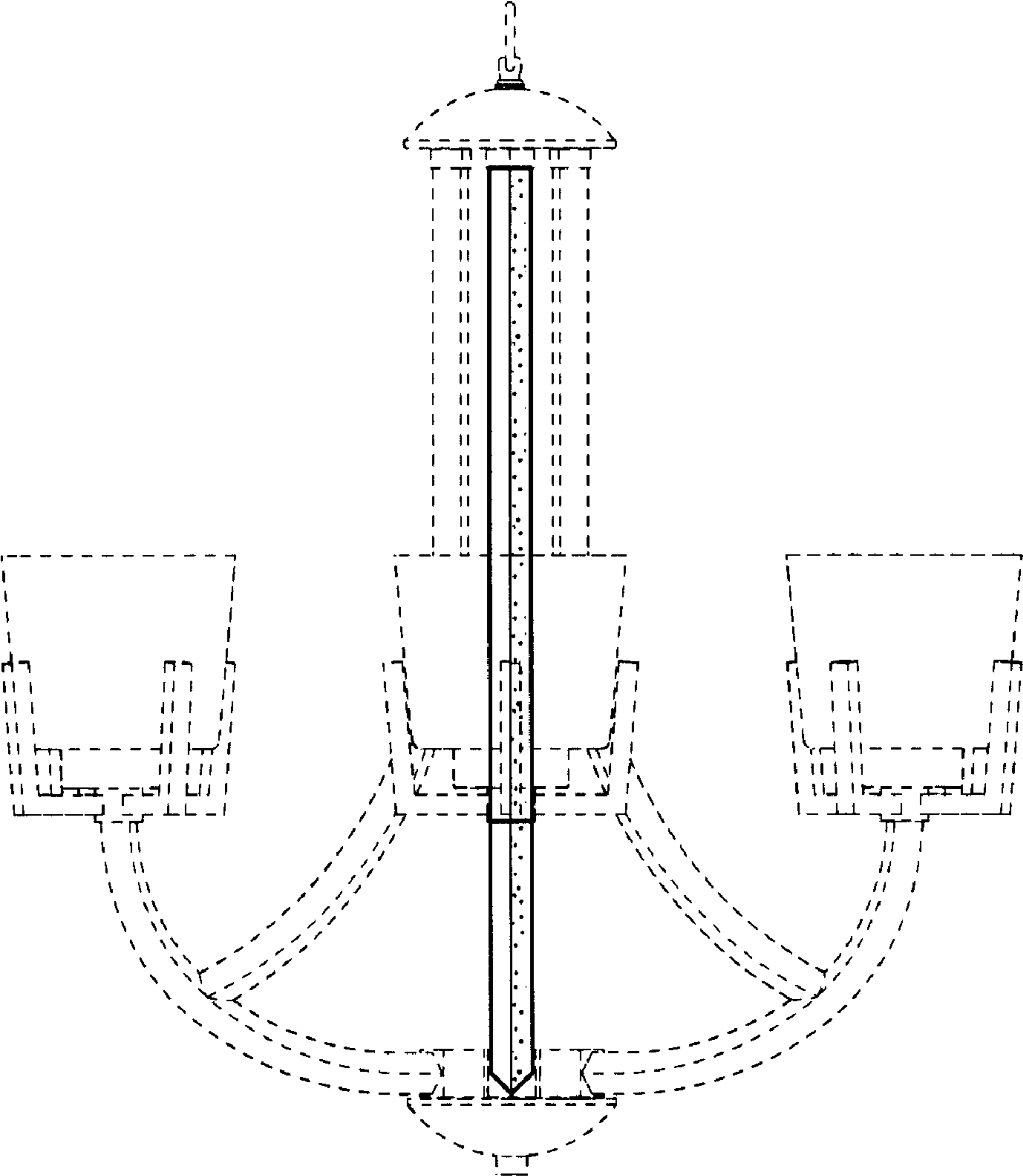

FIG. 3

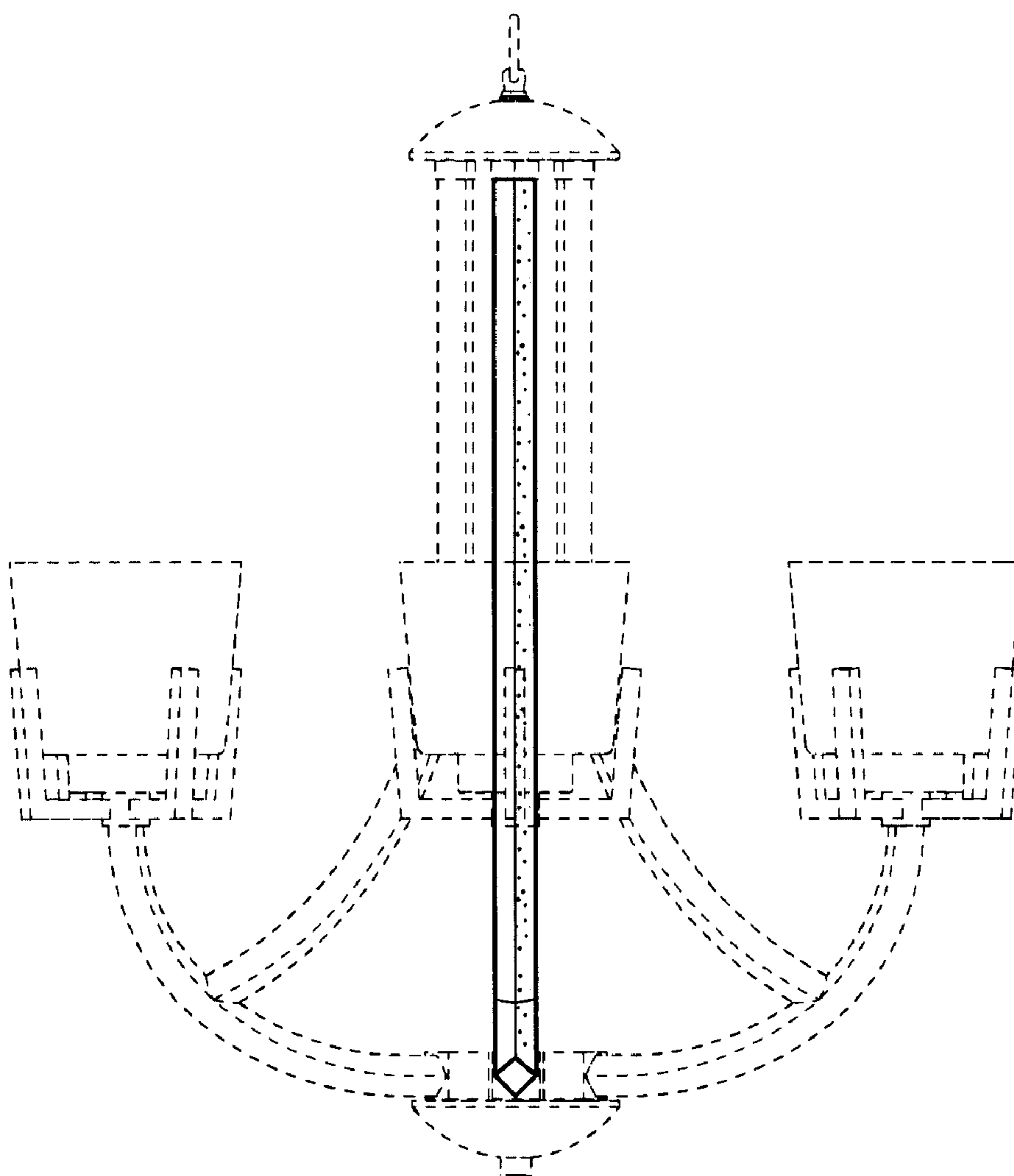

FIG. 4

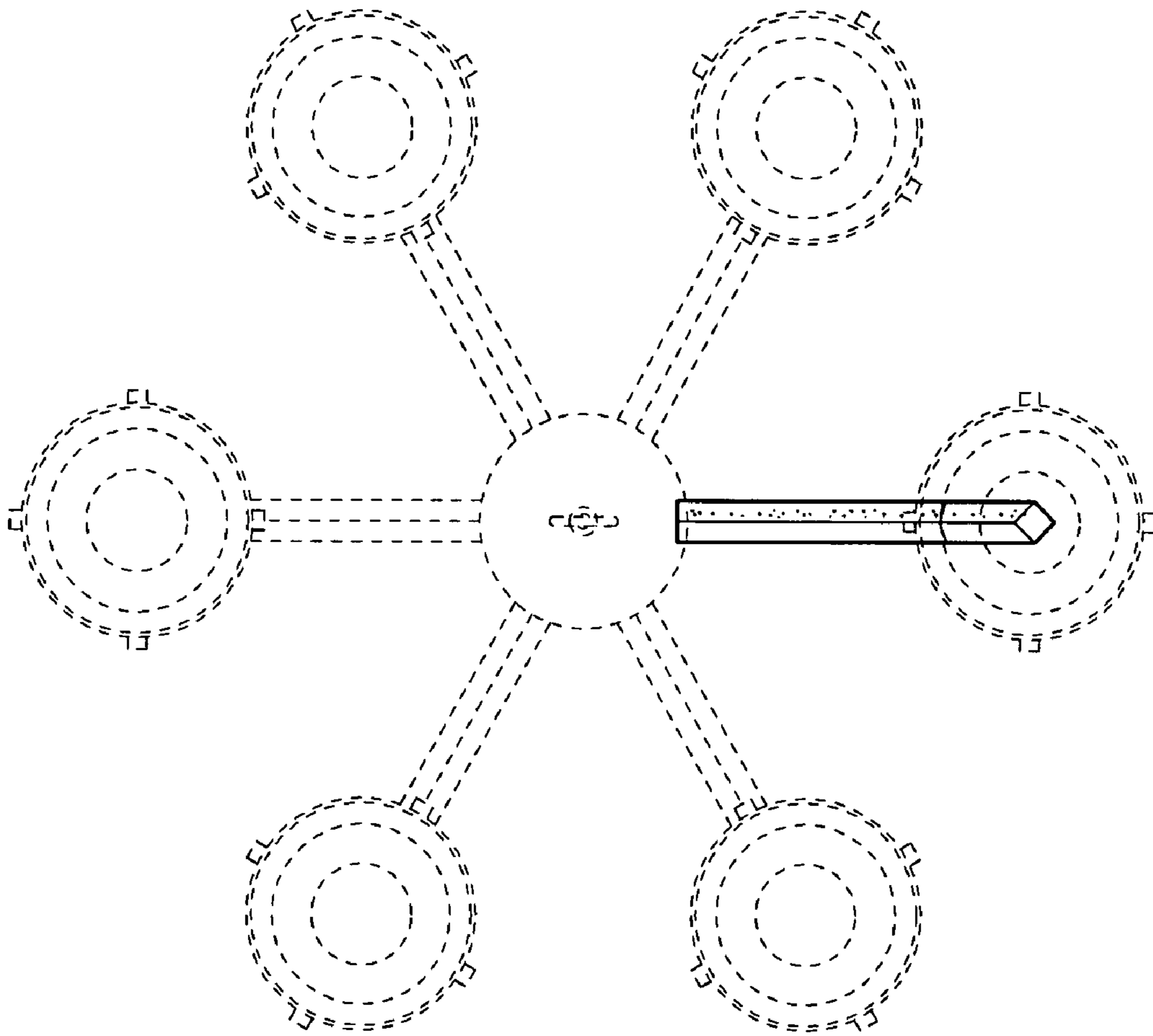

FIG. 5

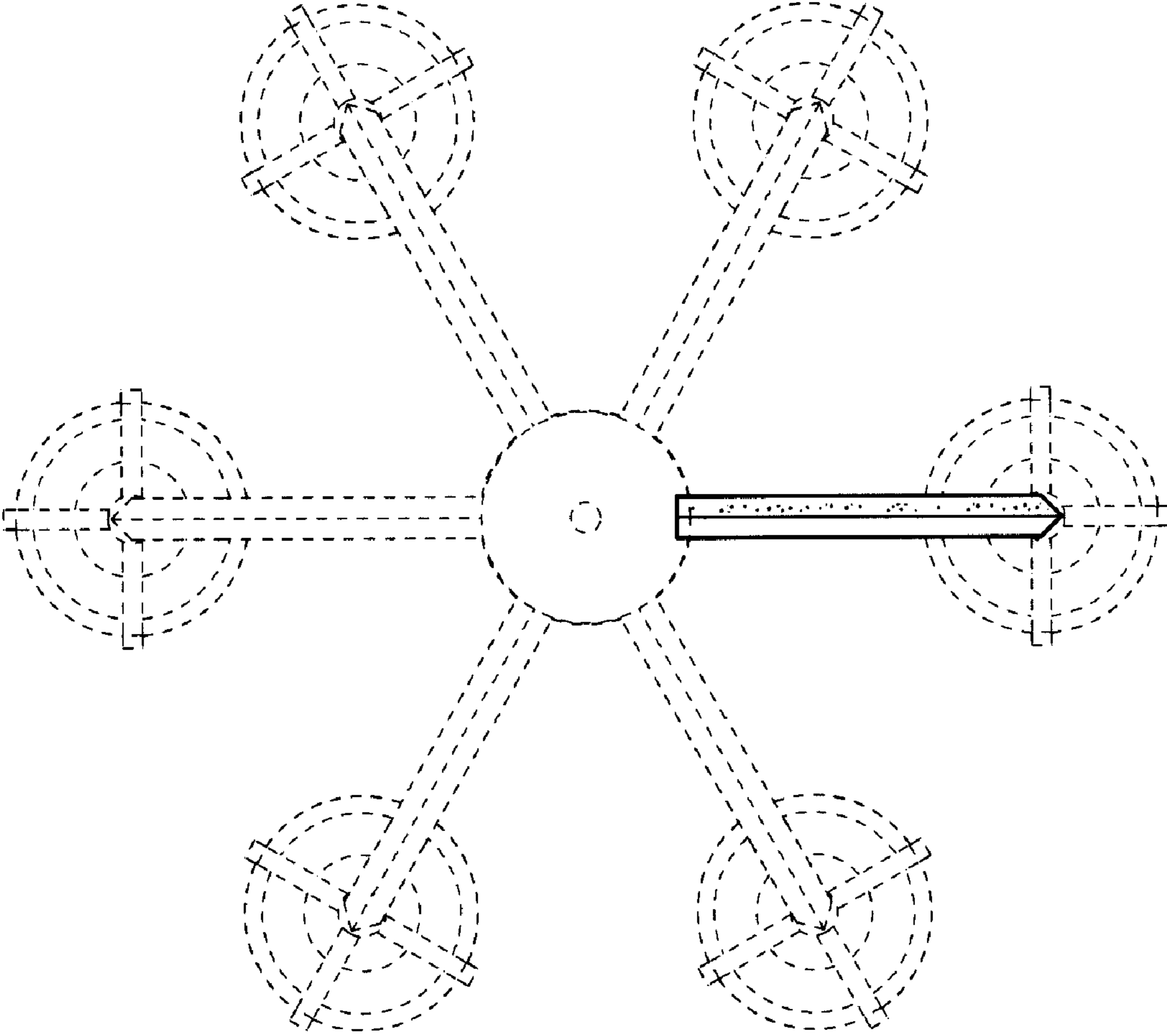

FIG. 6