

US00D546487S

(12) **United States Design Patent**  
**Sinkwitz**

(10) **Patent No.:** **US D546,487 S**  
(45) **Date of Patent:** **\*\* Jul. 10, 2007**

(54) **SURFACE CONFIGURATION OF A  
TAILLIGHT FOR A VEHICLE**

FOREIGN PATENT DOCUMENTS

DE M9607317.9 8/1996

(75) Inventor: **Hartmut Sinkwitz**, Heimsheim (DE)

\* cited by examiner

(73) Assignee: **smart GmbH**, Boeblingen (DE)

*Primary Examiner*—Marcus A. Jackson

(\*\*) Term: **14 Years**

(74) *Attorney, Agent, or Firm*—Crowell & Moring LLP

(21) Appl. No.: **29/267,012**

(57) **CLAIM**

(22) Filed: **Oct. 4, 2006**

The ornamental design for a surface configuration of a taillight for a vehicle, as shown and described.

(30) **Foreign Application Priority Data**

**DESCRIPTION**

Apr. 27, 2006 (DE) ..... 4 06 02 372

FIG. 1 is a perspective view of a first embodiment of a surface configuration of a taillight for a vehicle according to my novel design;

(51) **LOC (8) Cl.** ..... **26-06**

FIG. 2 is a side view thereof; and

(52) **U.S. Cl.** ..... **D26/28**

FIG. 3 is a front view thereof.

(58) **Field of Classification Search** ..... D26/28-36;  
362/459-468, 475-478, 485-487  
See application file for complete search history.

FIG. 4 is a perspective view of a second embodiment of the surface configuration of a taillight for a vehicle according to my novel design;

(56) **References Cited**

FIG. 5 is a side view thereof; and,

U.S. PATENT DOCUMENTS

FIG. 6 is a front view thereof.

- D388,200 S 12/1997 Tomforde et al.
- D389,783 S 1/1998 Tomforde et al.
- D496,113 S \* 9/2004 Lin ..... D26/28
- D511,583 S \* 11/2005 Tanaka et al. .... D26/28

The broken lines are for illustrative purposes only and form no part of the claimed design.

**1 Claim, 4 Drawing Sheets**

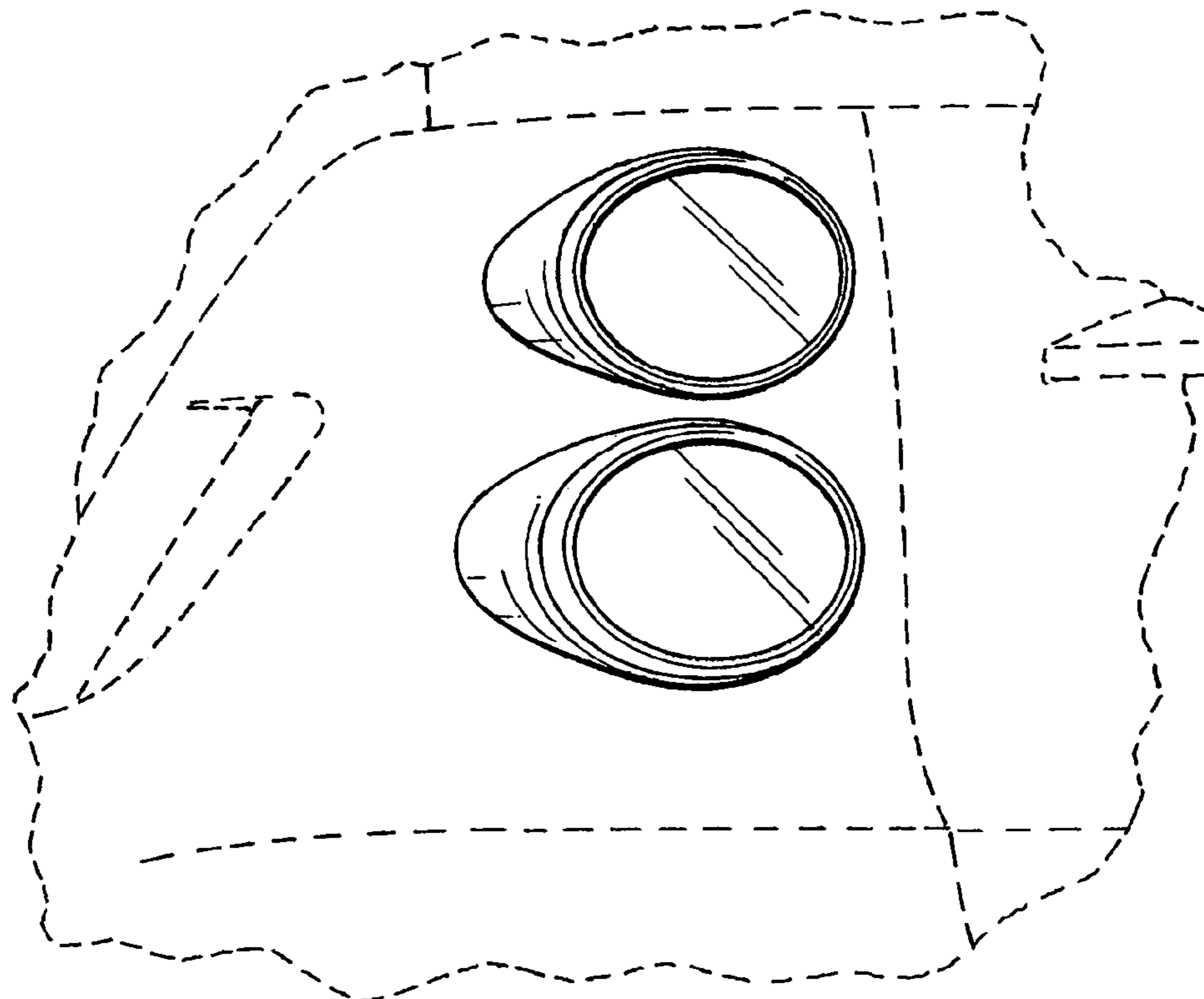

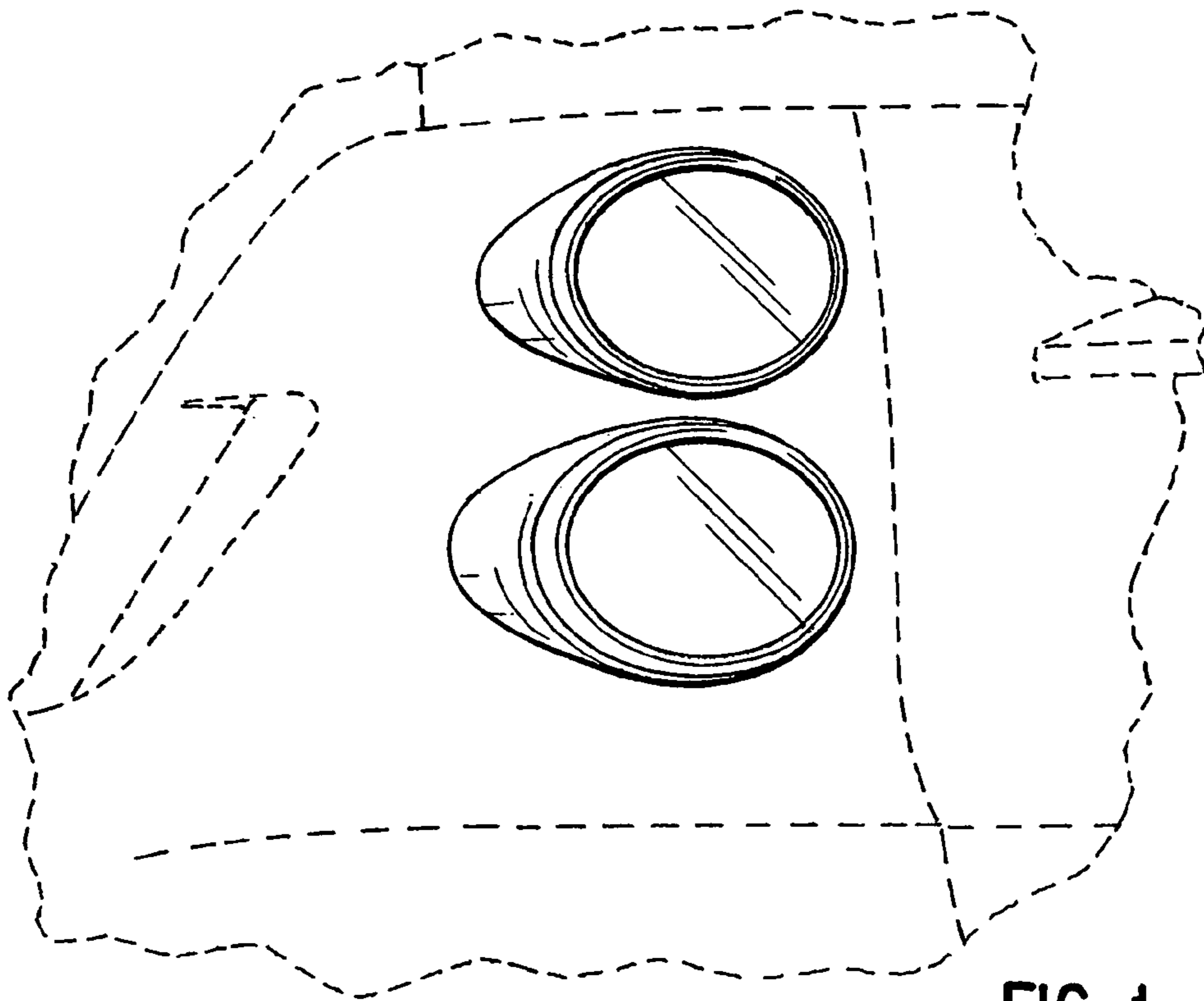

FIG. 1

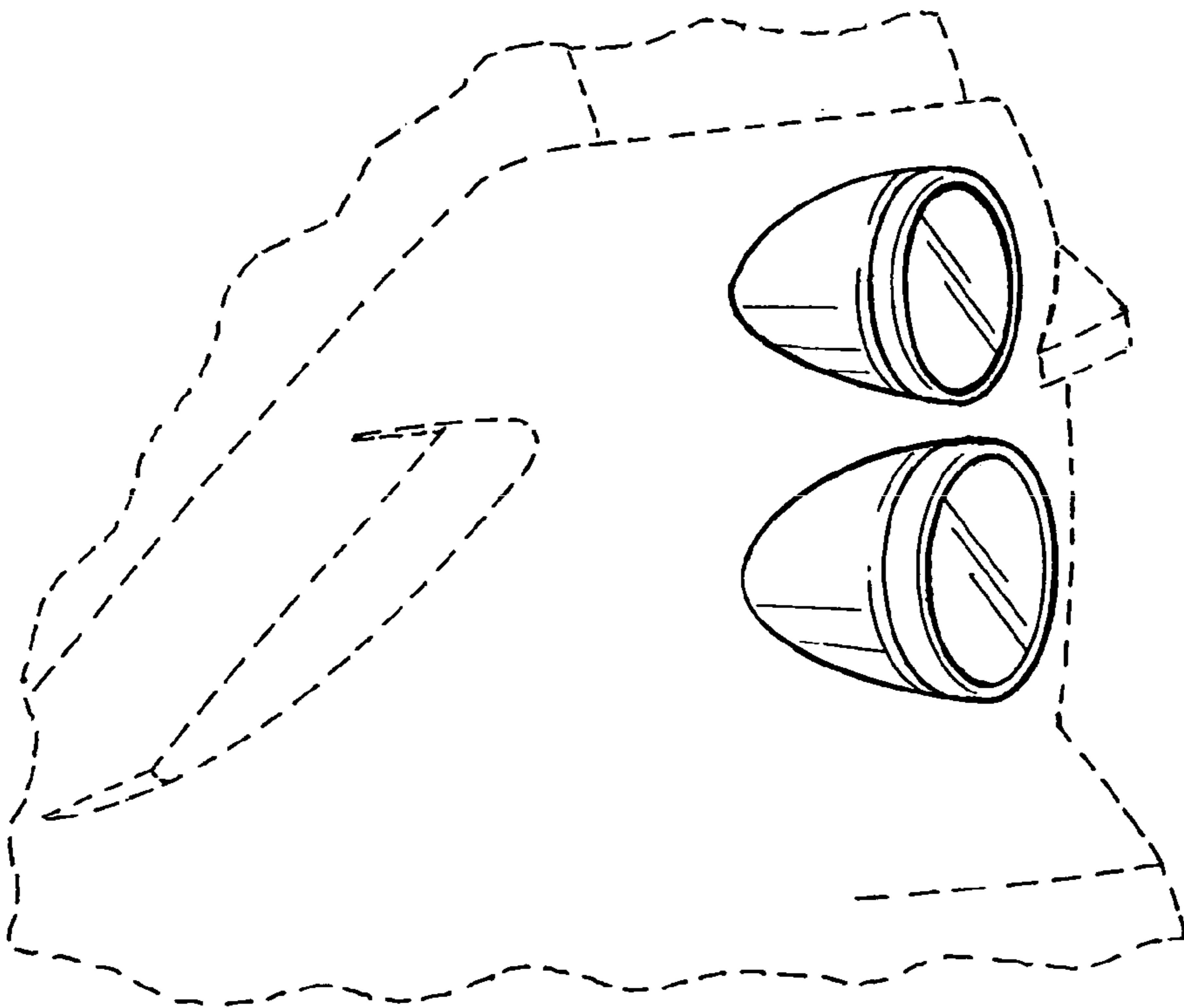
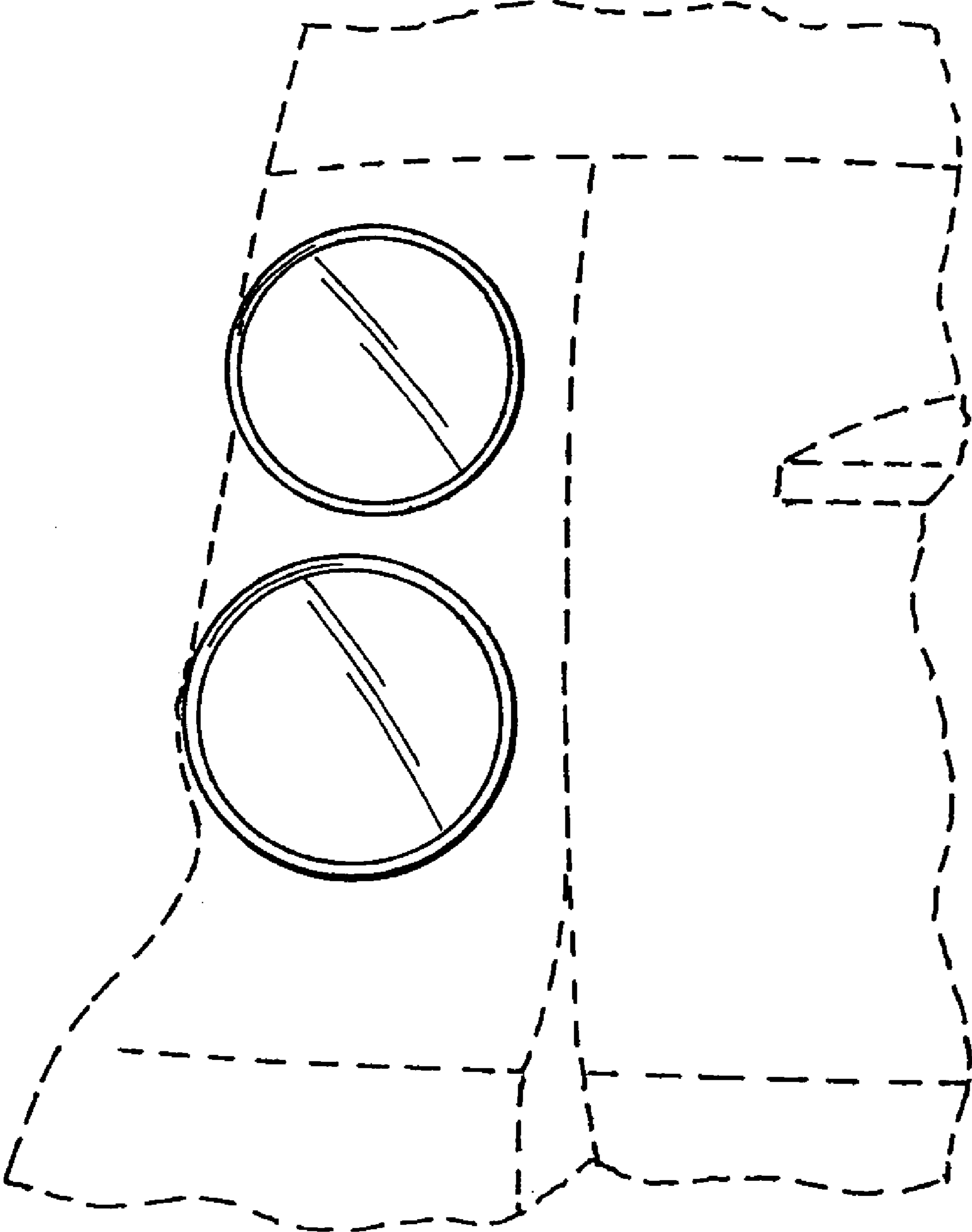

FIG. 2



**FIG. 3**

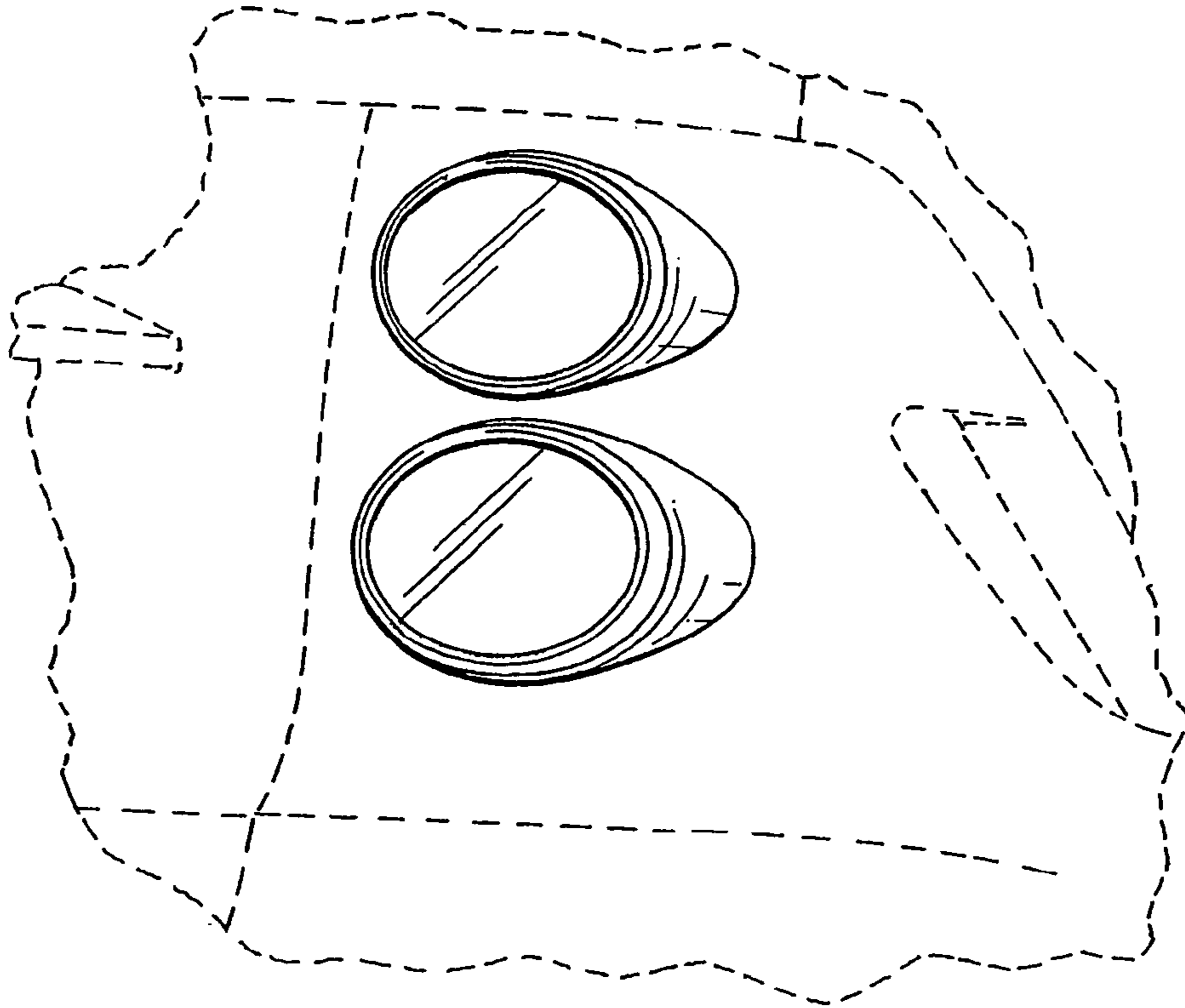

FIG. 4

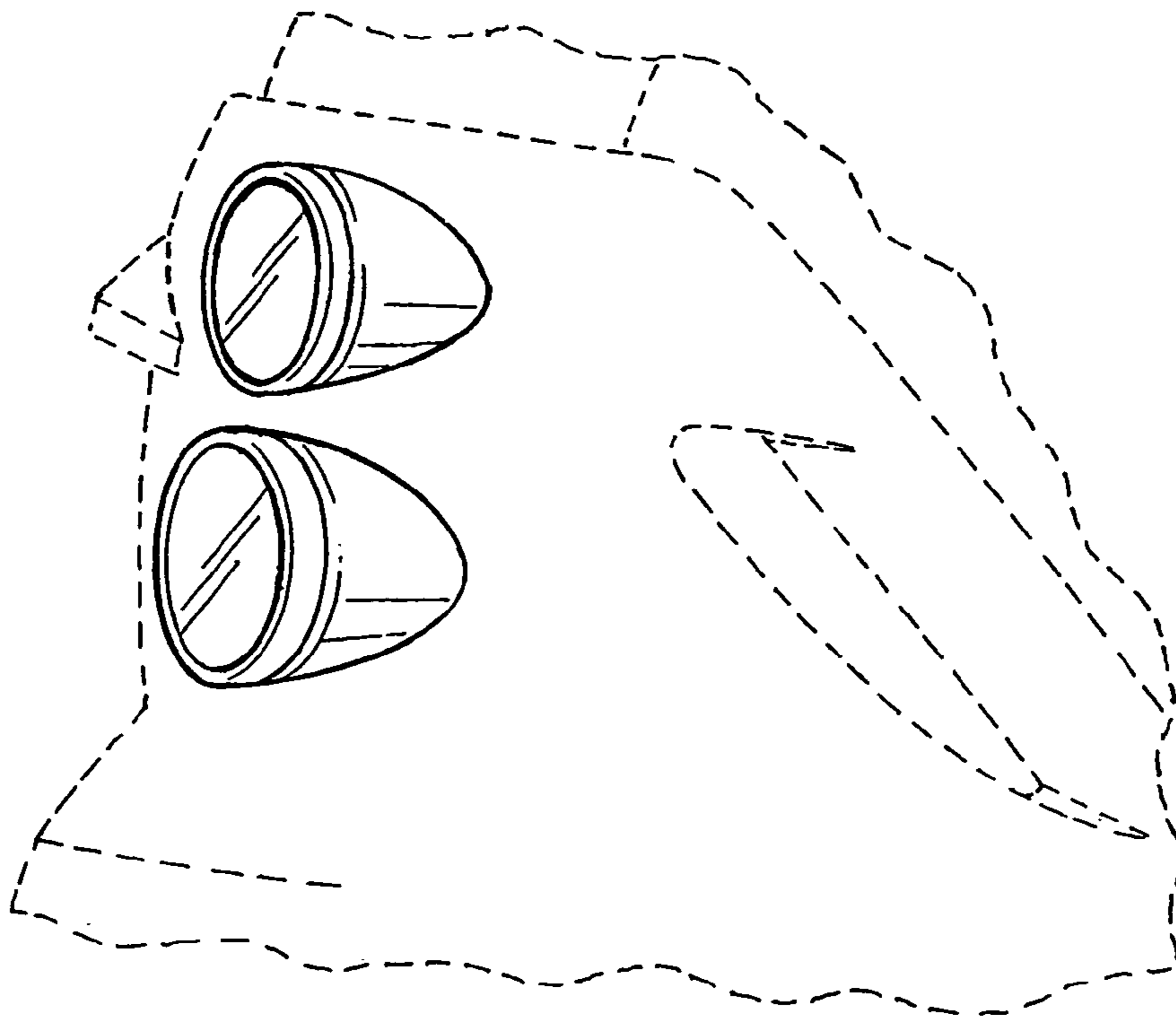
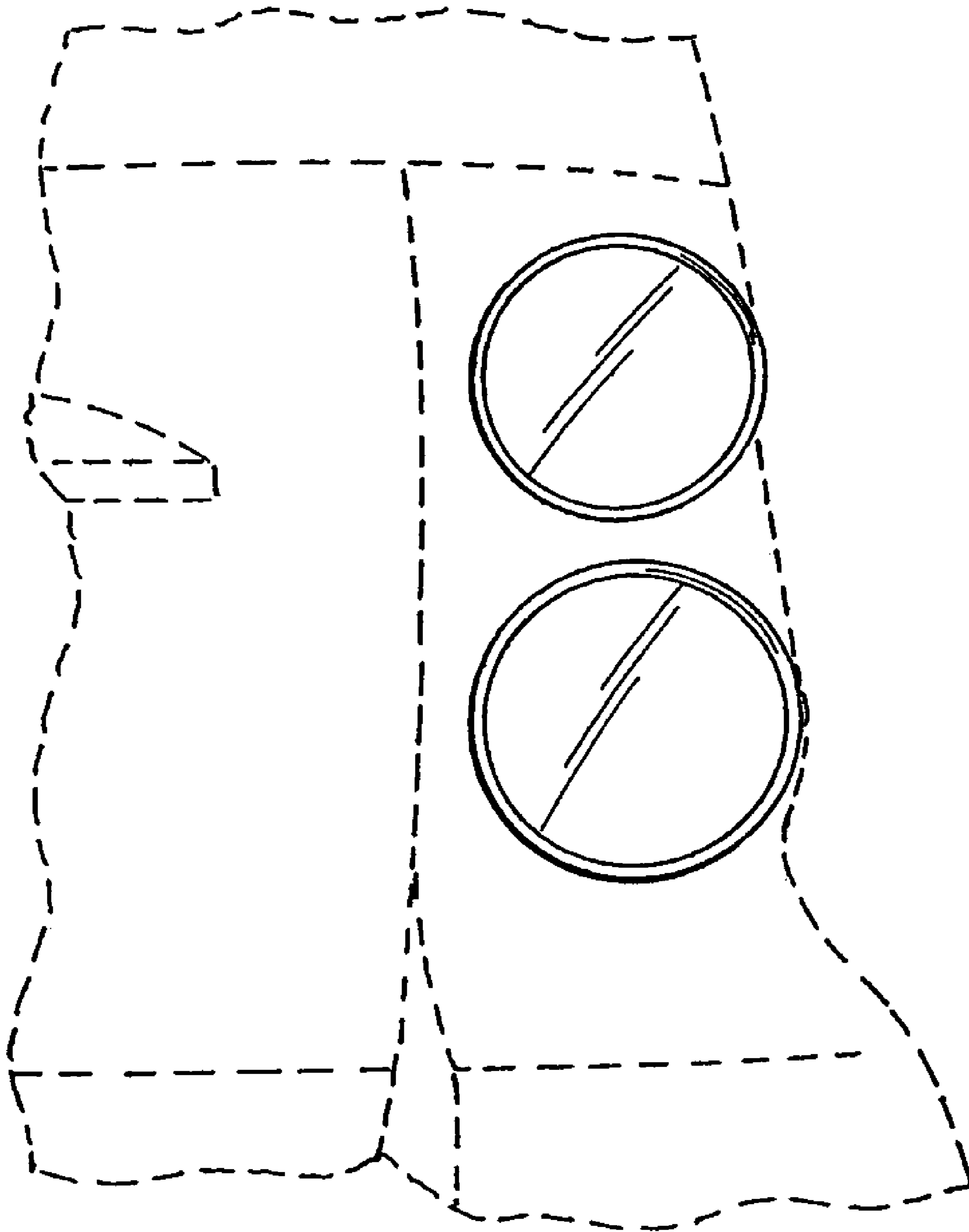

FIG. 5



**FIG. 6**