

US00D546440S

(12) **United States Design Patent**
Burnside

(10) **Patent No.:** **US D546,440 S**
(45) **Date of Patent:** **** Jul. 10, 2007**

(54) **INJECTABLE POWER PORT**
(75) Inventor: **Eddie K. Burnside**, Morgan, UT (US)
(73) Assignee: **C.R. Bard, Inc.**, Murray Hill, NJ (US)
(**) Term: **14 Years**

(21) Appl. No.: **29/239,163**
(22) Filed: **Sep. 27, 2005**

(51) **LOC (8) Cl.** **24-01**
(52) **U.S. Cl.** **D24/108**
(58) **Field of Classification Search** D13/167;
D24/108, 111; 604/288.01-288.04, 175
See application file for complete search history.

(56) **References Cited**

U.S. PATENT DOCUMENTS

4,781,680	A *	11/1988	Redmond et al.	604/288.02
5,013,298	A	5/1991	Moden et al.	
5,045,060	A	9/1991	Melsky et al.	
D337,637	S *	7/1993	Tucker	D24/111
5,558,641	A *	9/1996	Glantz et al.	604/288.02
5,743,873	A *	4/1998	Cai et al.	604/288.02
6,090,066	A	7/2000	Schnell	
6,113,572	A *	9/2000	Gailey et al.	604/93.01
D445,175	S *	7/2001	Bertheas	D24/108
6,478,783	B1 *	11/2002	Moorehead	604/288.02

6,527,754	B1	3/2003	Tallarida et al.	
6,878,137	B2	4/2005	Benchetrit	
2005/0283119	A1 *	12/2005	Uth et al.	604/175
2006/0116648	A1 *	6/2006	Hamatake	604/288.02
2006/0247584	A1 *	11/2006	Sheetz et al.	604/288.02

* cited by examiner

Primary Examiner—Selina Sikder

(74) *Attorney, Agent, or Firm*—Kevin B. Laurence; Stoel Rives LLP

(57) **CLAIM**

The ornamental design for a injectable power port, as shown and described.

DESCRIPTION

FIG. 1 is a perspective view of an injectable power port according to the present invention;

FIG. 2 is a top view thereof;

FIG. 3 is a bottom view thereof;

FIG. 4 is a right side elevation view thereof;

FIG. 5 is a left side elevation view thereof; and,

FIG. 6 is a rear elevation view thereof.

The broken line showing of the environment is for illustrative purpose only and forms no part of the claimed design.

1 Claim, 3 Drawing Sheets

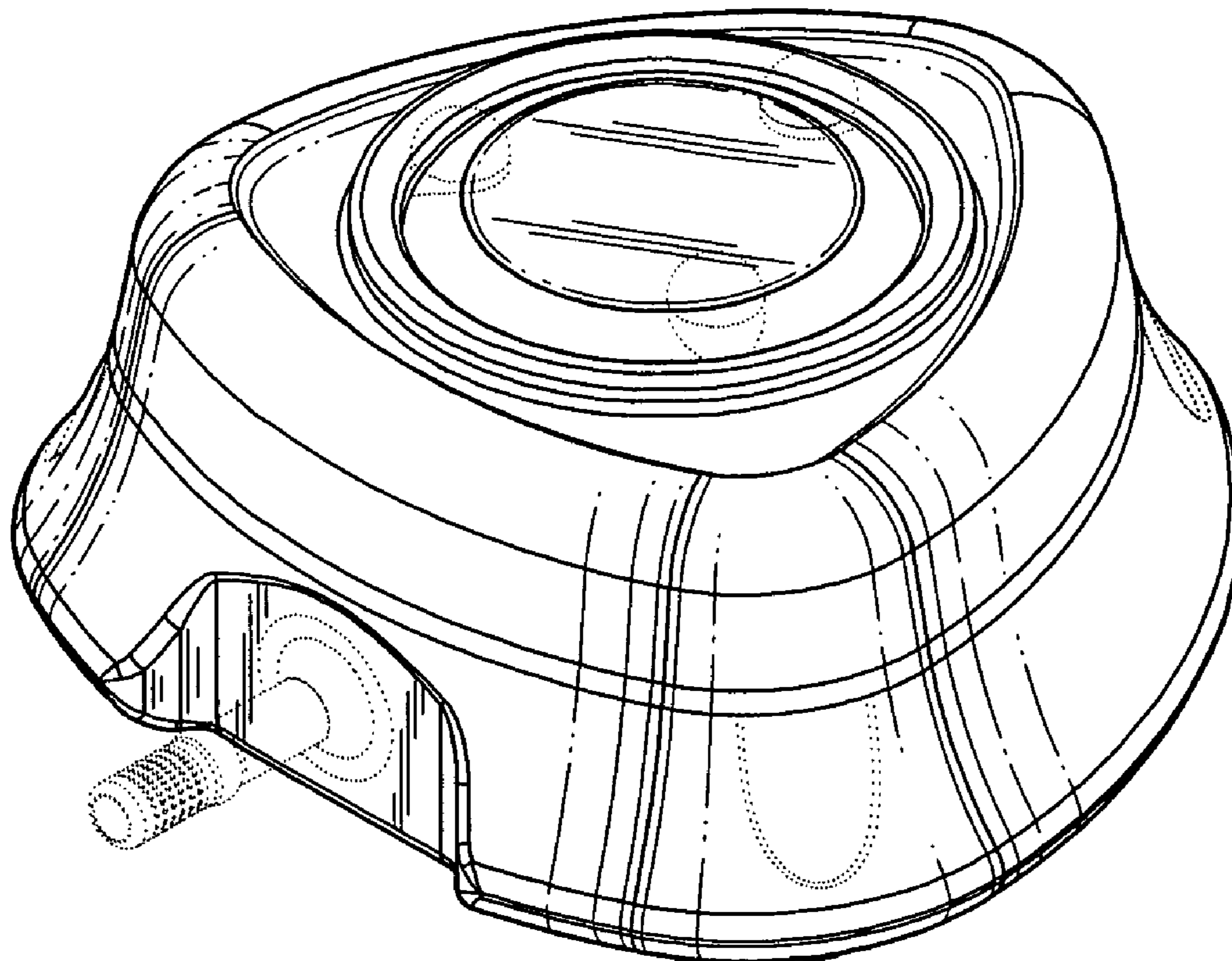

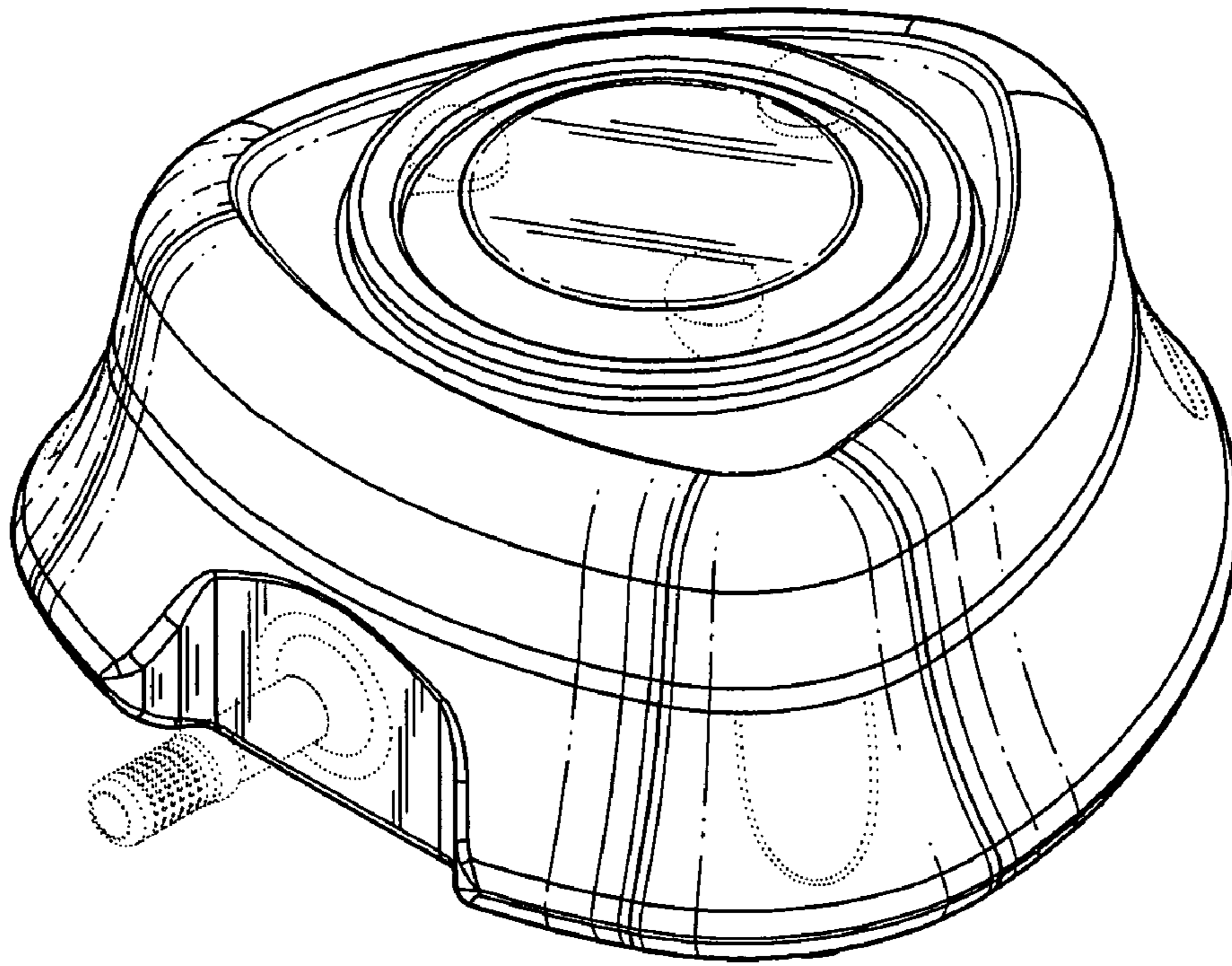

FIG. 1

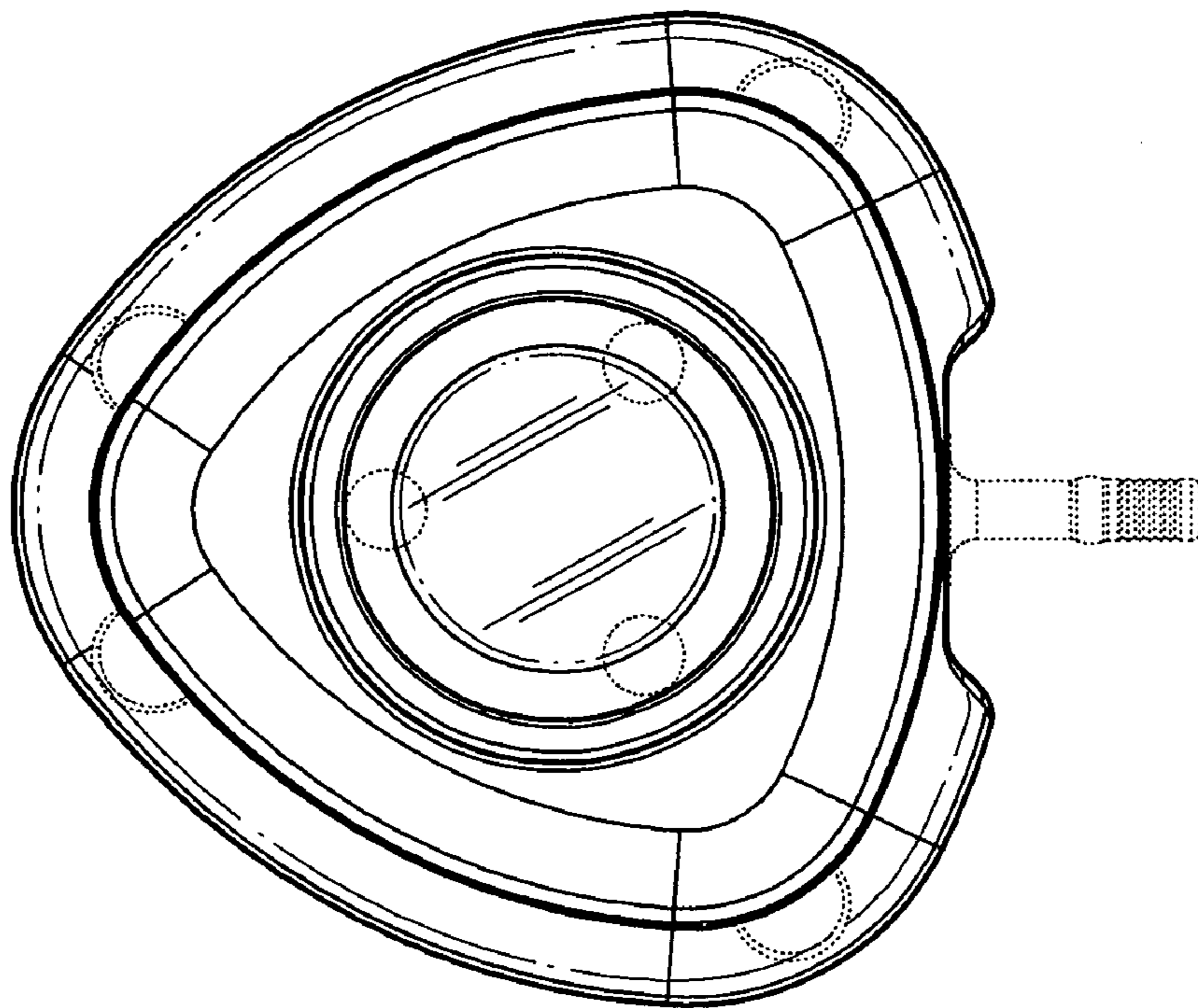

FIG. 2

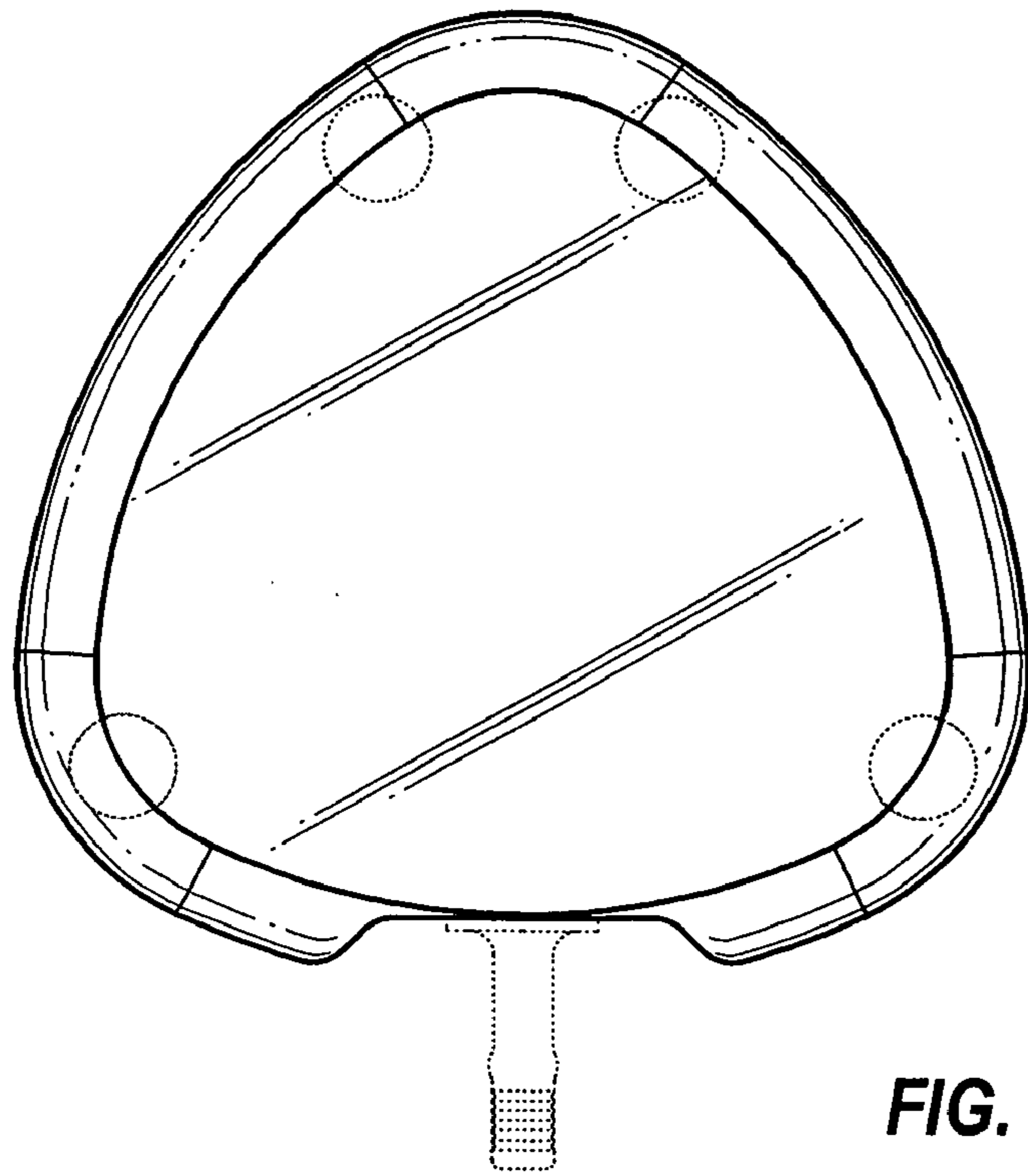

FIG. 3

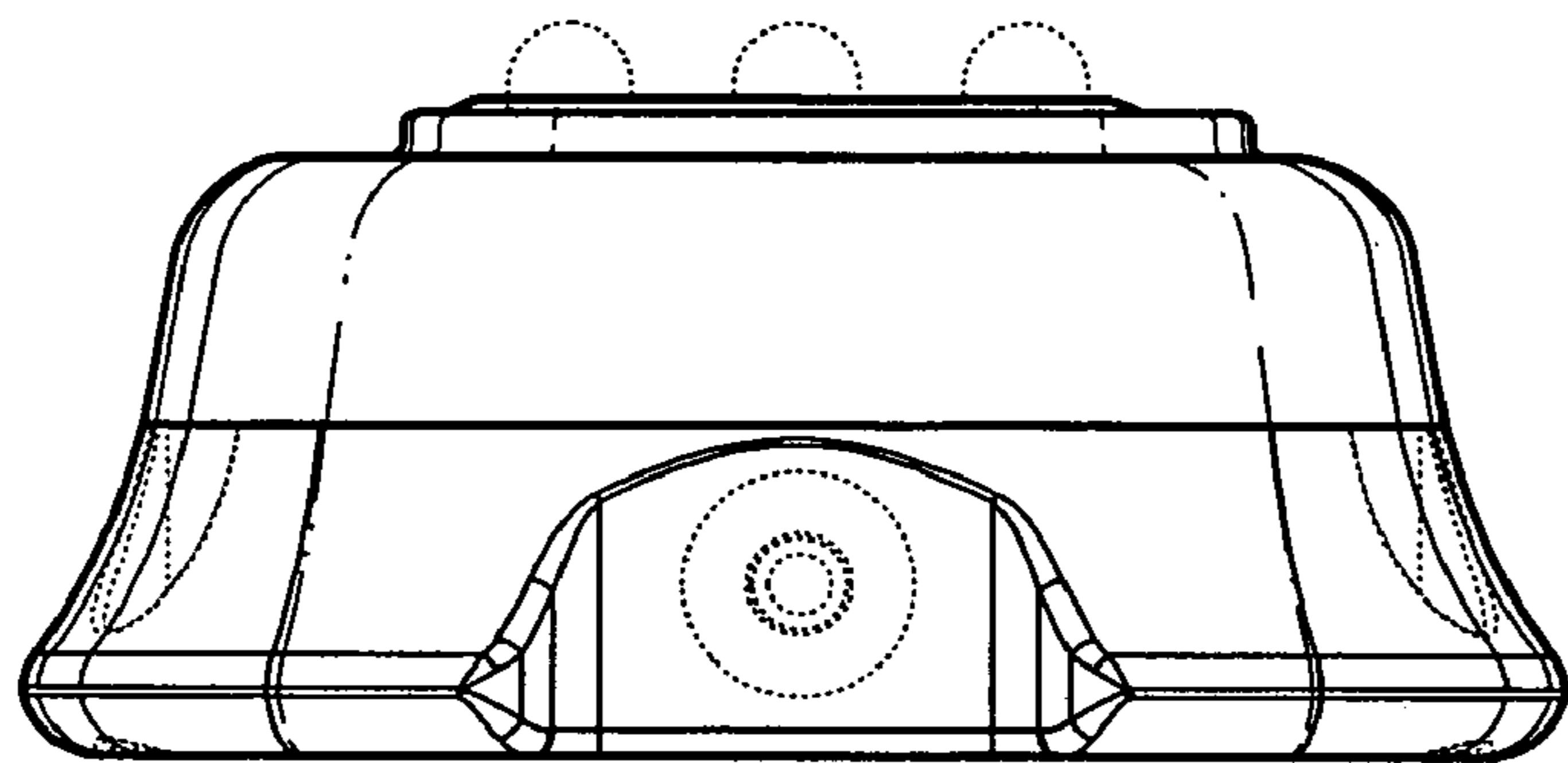

FIG. 4

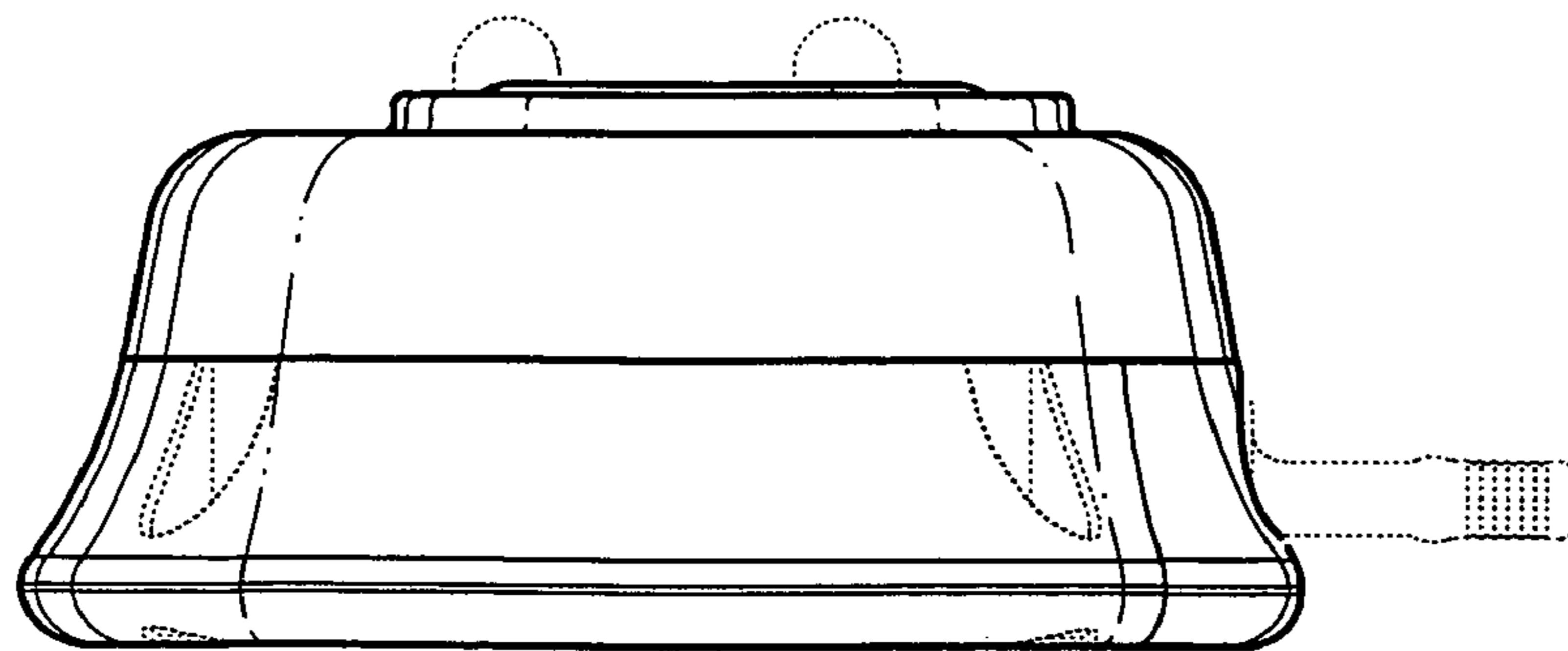

FIG. 5

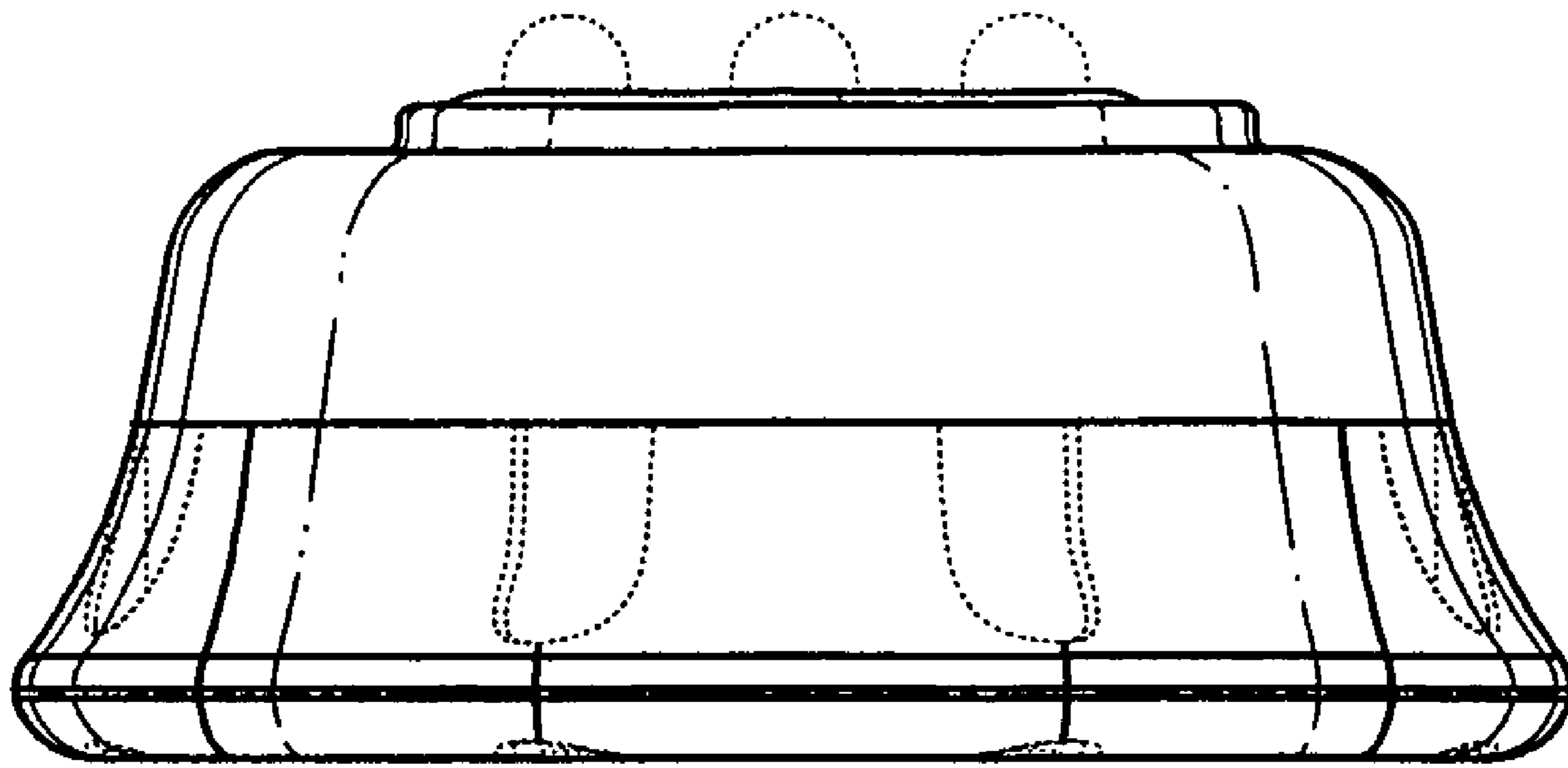

FIG. 6