

US00D545984S

(12) **United States Design Patent** (10) **Patent No.:** **US D545,984 S**  
**Leung et al.** (45) **Date of Patent:** **\*\* Jul. 3, 2007**

(54) **LANTERN**

(75) Inventors: **Vincent C. K. Leung**, Kowloon (HK);  
**James Michael Cormier**, Wichita, KS  
(US)

(73) Assignee: **The Coleman Company, Inc.**, Wichita,  
KS (US)

(\*\*) Term: **14 Years**

(21) Appl. No.: **29/237,819**

(22) Filed: **Sep. 7, 2005**

**Related U.S. Application Data**

(62) Division of application No. 29/193,108, filed on Nov.  
3, 2003.

(51) **LOC (8) Cl.** ..... **26-02**

(52) **U.S. Cl.** ..... **D26/40**

(58) **Field of Classification Search** ..... D26/40,  
D26/37, 33, 41, 42, 104, 119; 362/157, 158,  
362/171-174, 180, 616, 205, 208  
See application file for complete search history.

(56) **References Cited**

**U.S. PATENT DOCUMENTS**

D190,674 S *	6/1961	Hoenisch et al. ....	D26/41
D343,242 S *	1/1994	Poon .....	D26/42
D374,098 S *	9/1996	Lo .....	D26/37
D382,358 S *	8/1997	Poon .....	D26/42
D393,323 S *	4/1998	Howard et al. ....	D26/41
D421,660 S *	3/2000	Shing .....	D26/40
D429,354 S *	8/2000	Petterson .....	D26/40
D433,762 S *	11/2000	Yuen .....	D26/40
D443,088 S *	5/2001	Skidmore et al. ....	D26/40
D485,928 S	1/2004	Leung et al. ....	D26/40
D486,932 S *	2/2004	Dario et al. ....	D26/40
D486,933 S	2/2004	Leung et al. ....	D26/40

D486,934 S	2/2004	Leung et al. ....	D26/40
D487,809 S	3/2004	Leung et al. ....	D26/40
D509,921 S *	9/2005	Lam .....	D26/40
D513,336 S *	12/2005	Kung .....	D26/40
D524,968 S *	7/2006	Poon .....	D26/40

**OTHER PUBLICATIONS**

Coleman Collectors Guide 1903-1954, selected pages, published  
Mar. 1996.

\* cited by examiner

*Primary Examiner*—Ian Simmons

*Assistant Examiner*—Carissa Fitts

(74) *Attorney, Agent, or Firm*—Shook, Hardy & Bacon,  
L.L.P.

(57) **CLAIM**

The ornamental design for a lantern, as shown and  
described.

**DESCRIPTION**

FIG. 1 is a top, front perspective view of the lantern of the  
present invention showing the new design;

FIG. 2 is a bottom perspective view thereof;

FIG. 3 is a front elevation view thereof;

FIG. 4 is a rear elevation view thereof;

FIG. 5 is a side elevation view thereof;

FIG. 6 is a side elevation view thereof, showing the opposite  
side of FIG. 5;

FIG. 7 is a top plan view thereof; and,

FIG. 8 is a bottom plan view thereof.

The broken lines are directed to environment and are for  
illustrative purposes only, thus forming no part of the  
claimed design.

**1 Claim, 7 Drawing Sheets**

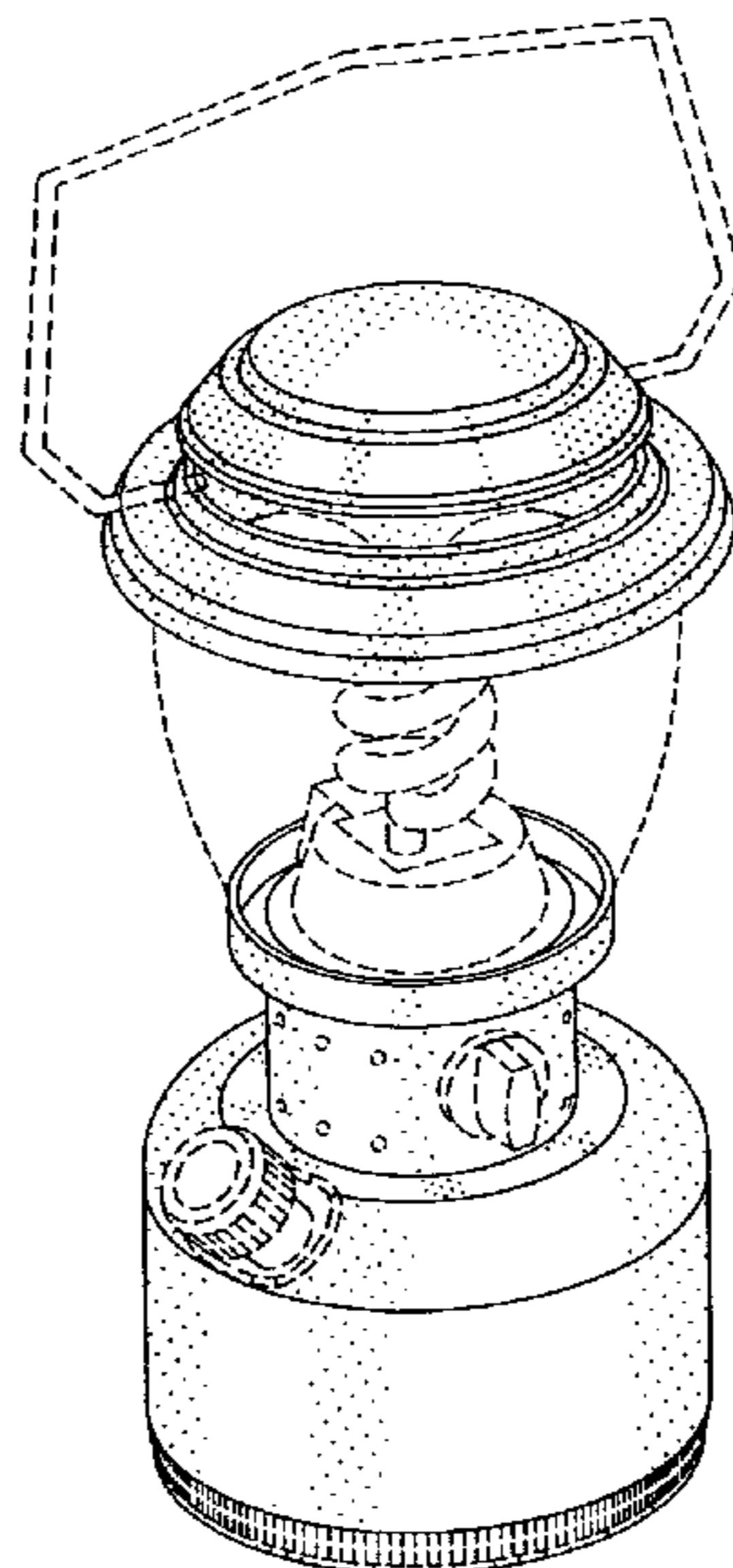

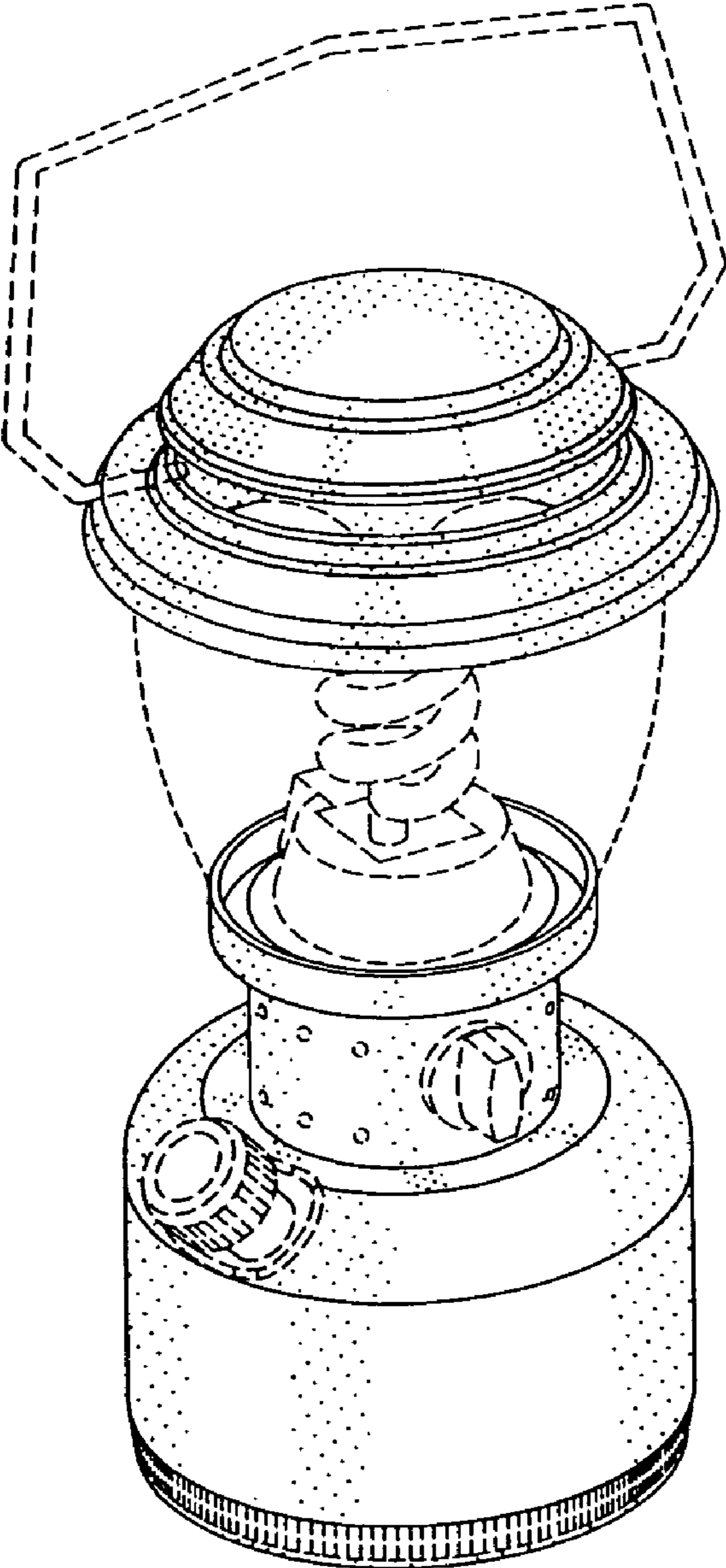

*FIG. 1*

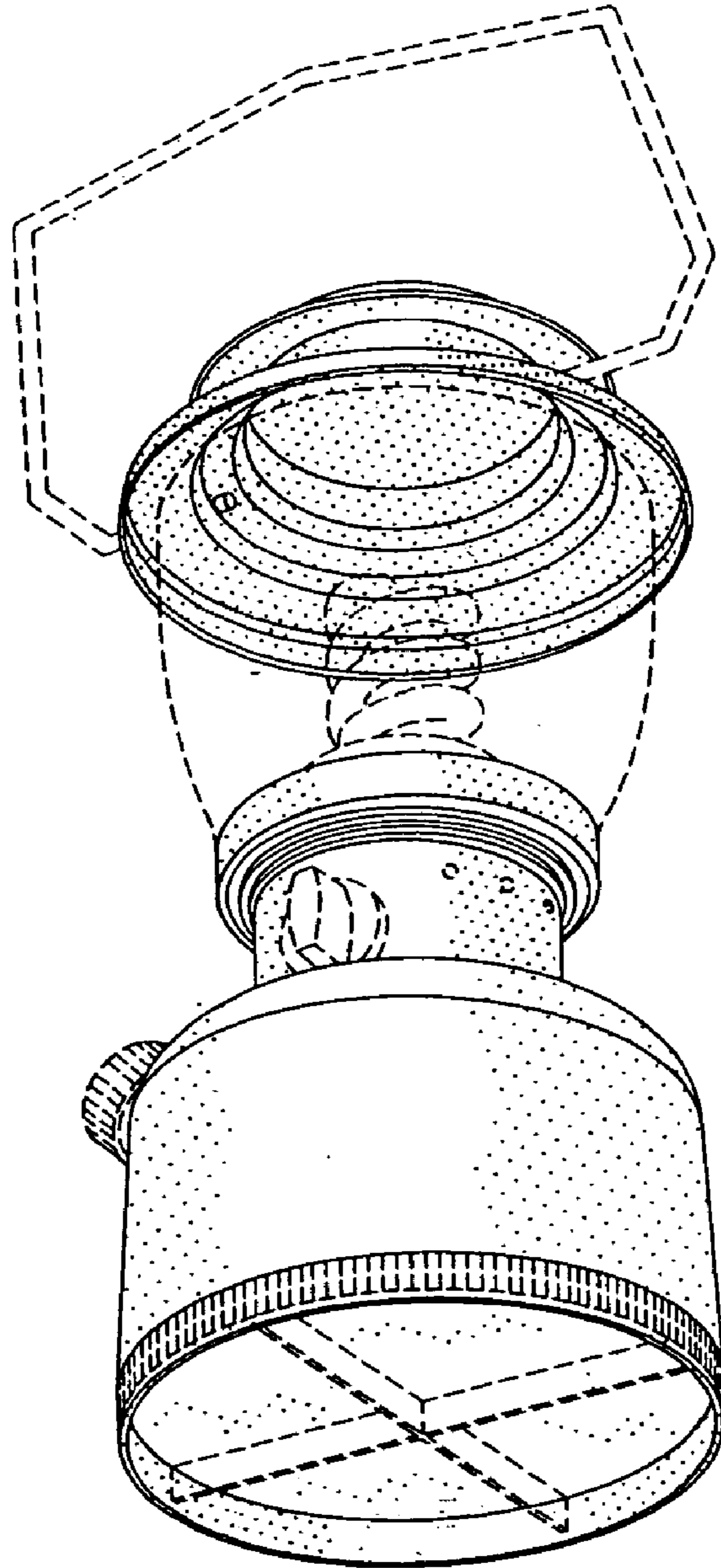

FIG. 2

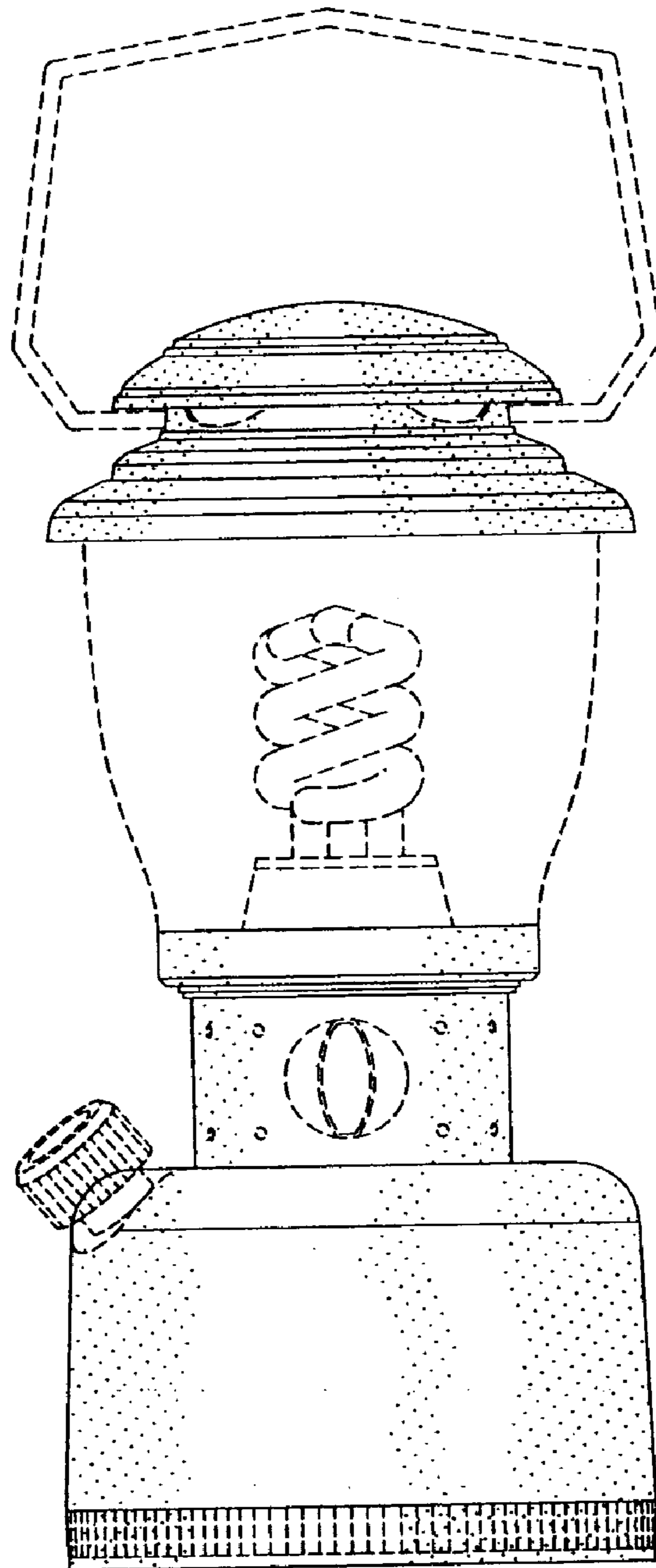

FIG. 3

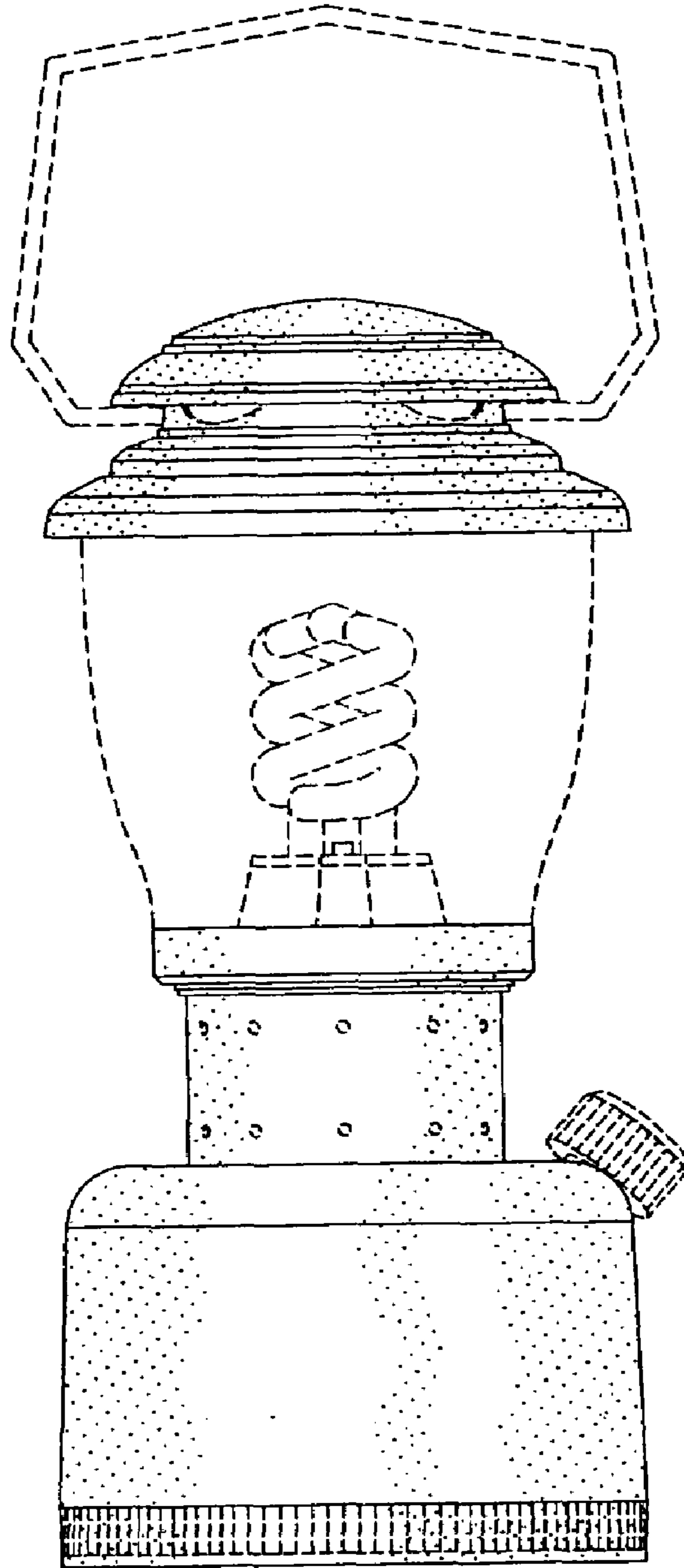
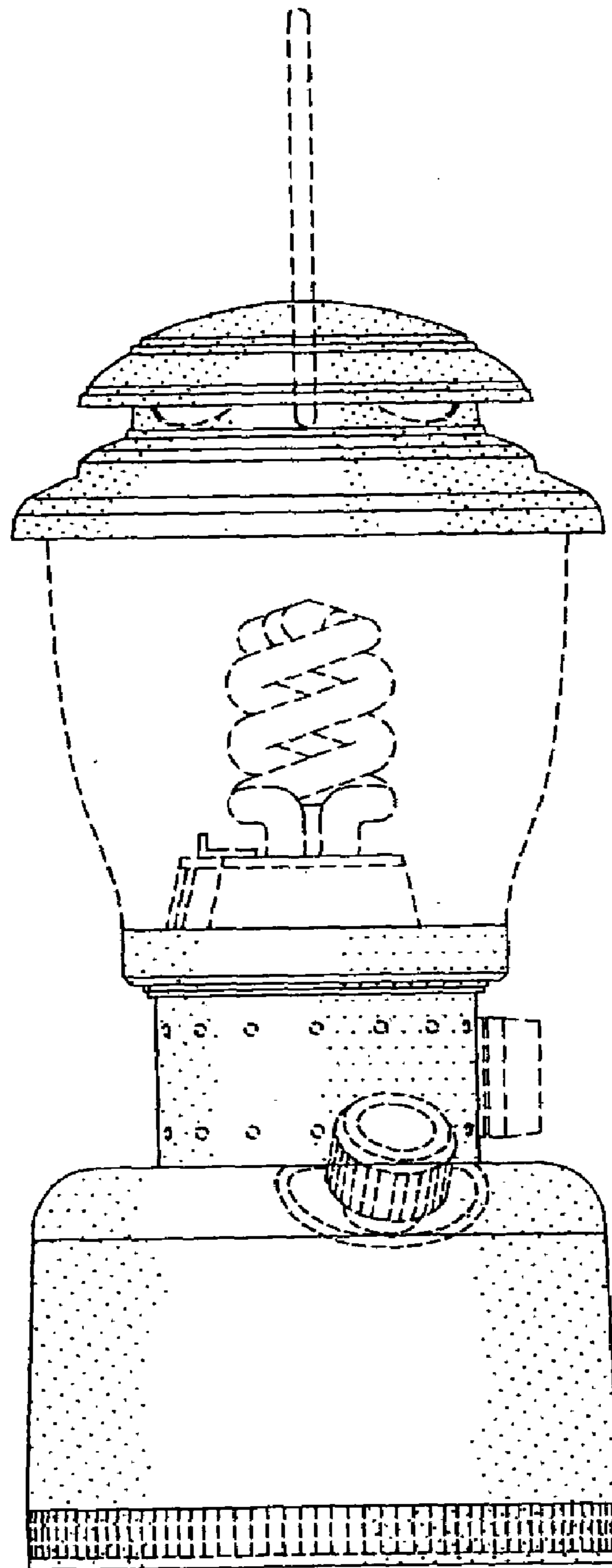
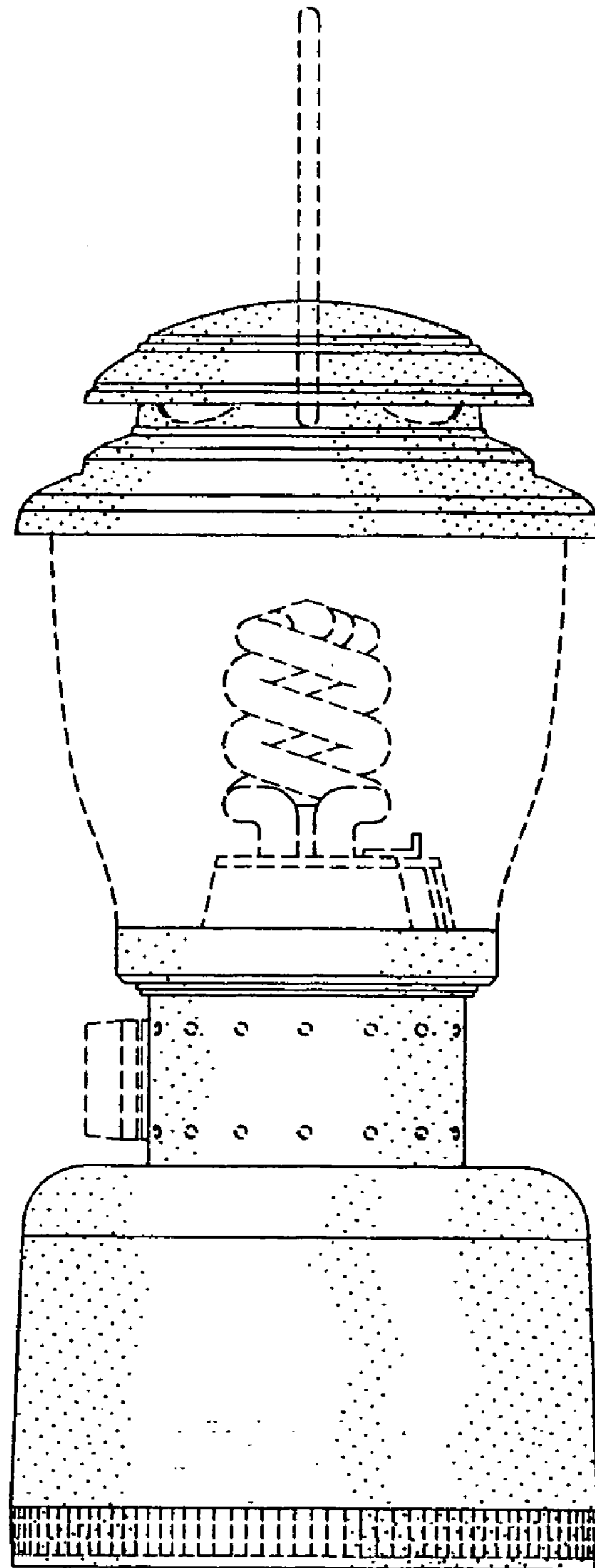

FIG. 4



*FIG. 5*



*FIG. 6*

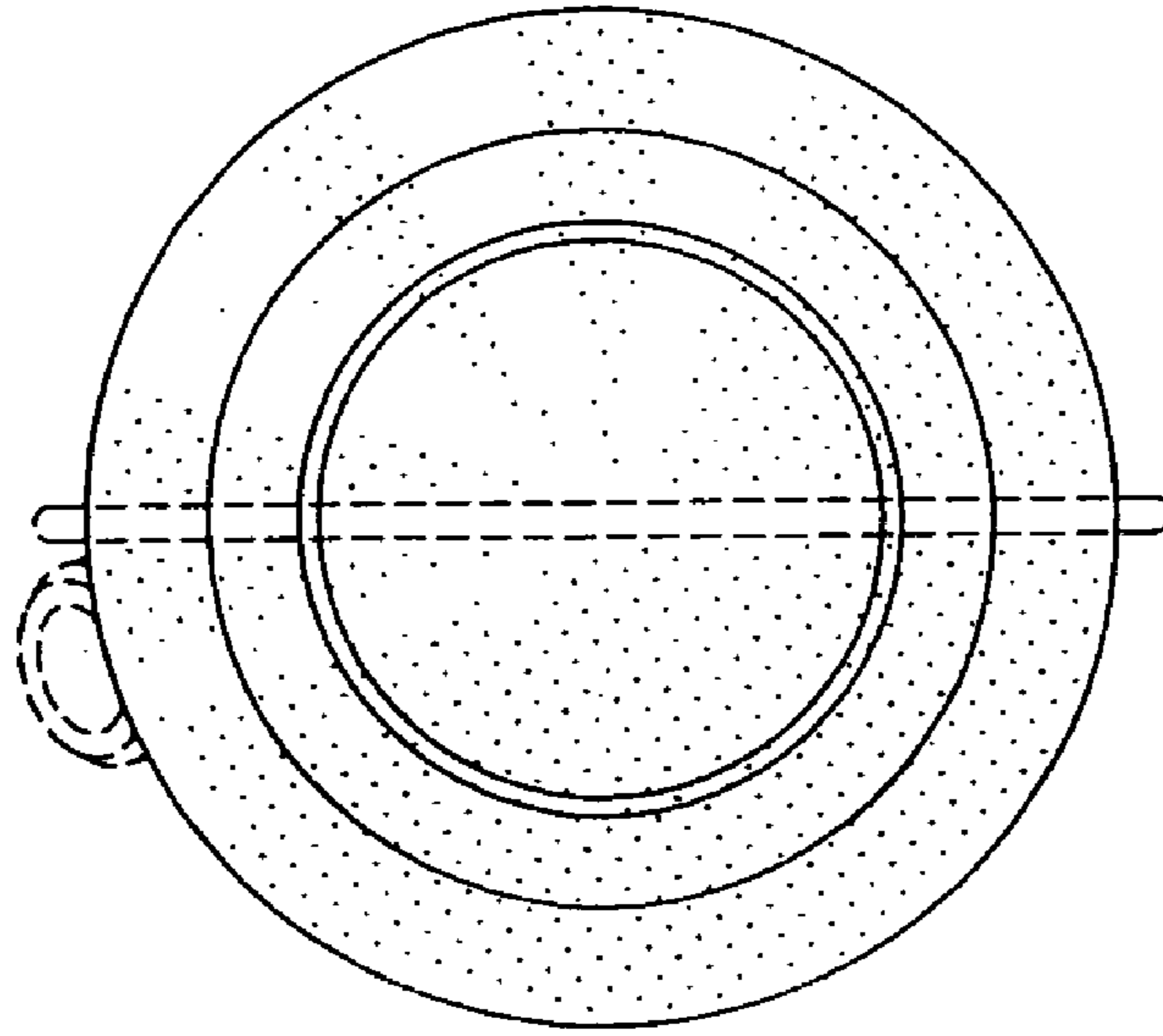

*FIG. 7*

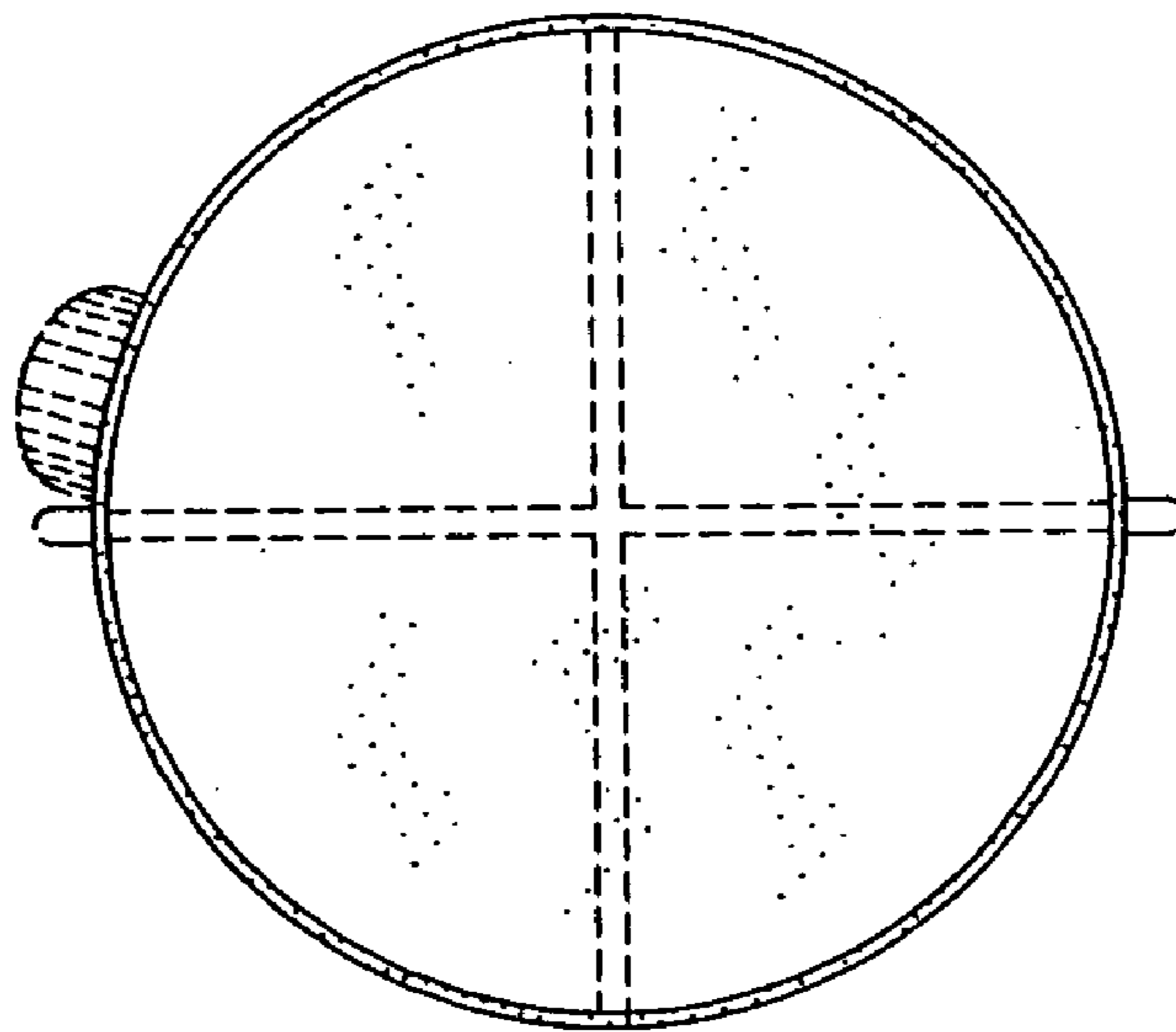

*FIG. 8*