



US00D545943S

(12) **United States Design Patent**
Rodgers et al.

(10) **Patent No.:** **US D545,943 S**
(45) **Date of Patent:** **** Jul. 3, 2007**

(54) **COATING MATERIAL DISPENSING DEVICE**

(75) Inventors: **Michael C. Rodgers**, Montpelier, OH (US); **Gene Paul Altenburger**, Maumee, OH (US); **Brian Shull**, Auburn, IN (US)

(73) Assignee: **Illinois Tool Works Inc.**, Glenview, IL (US)

(**) Term: **14 Years**

(21) Appl. No.: **29/255,952**

(22) Filed: **Mar. 14, 2006**

(51) **LOC (8) Cl.** **23-01**

(52) **U.S. Cl.** **D23/226**

(58) **Field of Classification Search** D23/213, D23/223, 226; 239/525-527, 690-691
See application file for complete search history.

(56) **References Cited**

U.S. PATENT DOCUMENTS

2,888,176 A 5/1959 Miller

(Continued)

FOREIGN PATENT DOCUMENTS

EP 0 846 904 A1 11/1997

(Continued)

OTHER PUBLICATIONS

“REA-90 and REA-90L Electrostatic Spray Guns Dual Atomization Technology”, Service Manual, Ransburg, 2005 Illinois Tool Works Inc.

(Continued)

Primary Examiner—Robin Webster

(74) *Attorney, Agent, or Firm*—Barnes & Thornburg LLP

(57) **CLAIM**

The ornamental design for a coating material dispensing device, as shown and described.

DESCRIPTION

FIG. 1 illustrates a right side elevational view of an embodiment of a coating material dispensing device showing our new design, with the left side elevational view being a mirror image of FIG. 1;

FIG. 2 illustrates a top plan view of the coating material dispensing device illustrated in FIG. 1;

FIG. 3 illustrates a front elevational view of the coating material dispensing device illustrated in FIGS. 1-2;

FIG. 4 illustrates a rear elevational view of the coating material dispensing device illustrated in FIGS. 1-3;

FIG. 5 illustrates a bottom plan view of the coating material dispensing device illustrated in FIGS. 1-4;

FIG. 6 illustrates a right side elevational view of another embodiment of a coating material dispensing device showing our new design, with the left side elevational view being a mirror image of FIG. 6;

FIG. 7 illustrates a top plan view of the coating material dispensing device illustrated in FIG. 6;

FIG. 8 illustrates a front elevational view of the coating material dispensing device illustrated in FIGS. 6-7;

FIG. 9 illustrates a rear elevational view of the coating material dispensing device illustrated in FIGS. 6-8;

FIG. 10 illustrates a bottom plan view of the coating material dispensing device illustrated in FIGS. 6-9;

FIG. 11 illustrates a fragmentary right side elevational view of another embodiment of a coating material dispensing device showing our new design, with the left side elevational view being a mirror image of FIG. 11;

FIG. 12 illustrates a fragmentary top plan view of the coating material dispensing device illustrated in FIG. 11;

FIG. 13 illustrates a front elevational view of the coating material dispensing device illustrated in FIGS. 11-12;

FIG. 14 illustrates a rear elevational view of the coating material dispensing device illustrated in FIGS. 11-13; and,

FIG. 15 illustrates a fragmentary bottom plan view of the coating material dispensing device illustrated in FIGS. 11-14.

The claimed design is shown fragmented in FIGS. 11-15 to indicate indeterminate length.

1 Claim, 6 Drawing Sheets

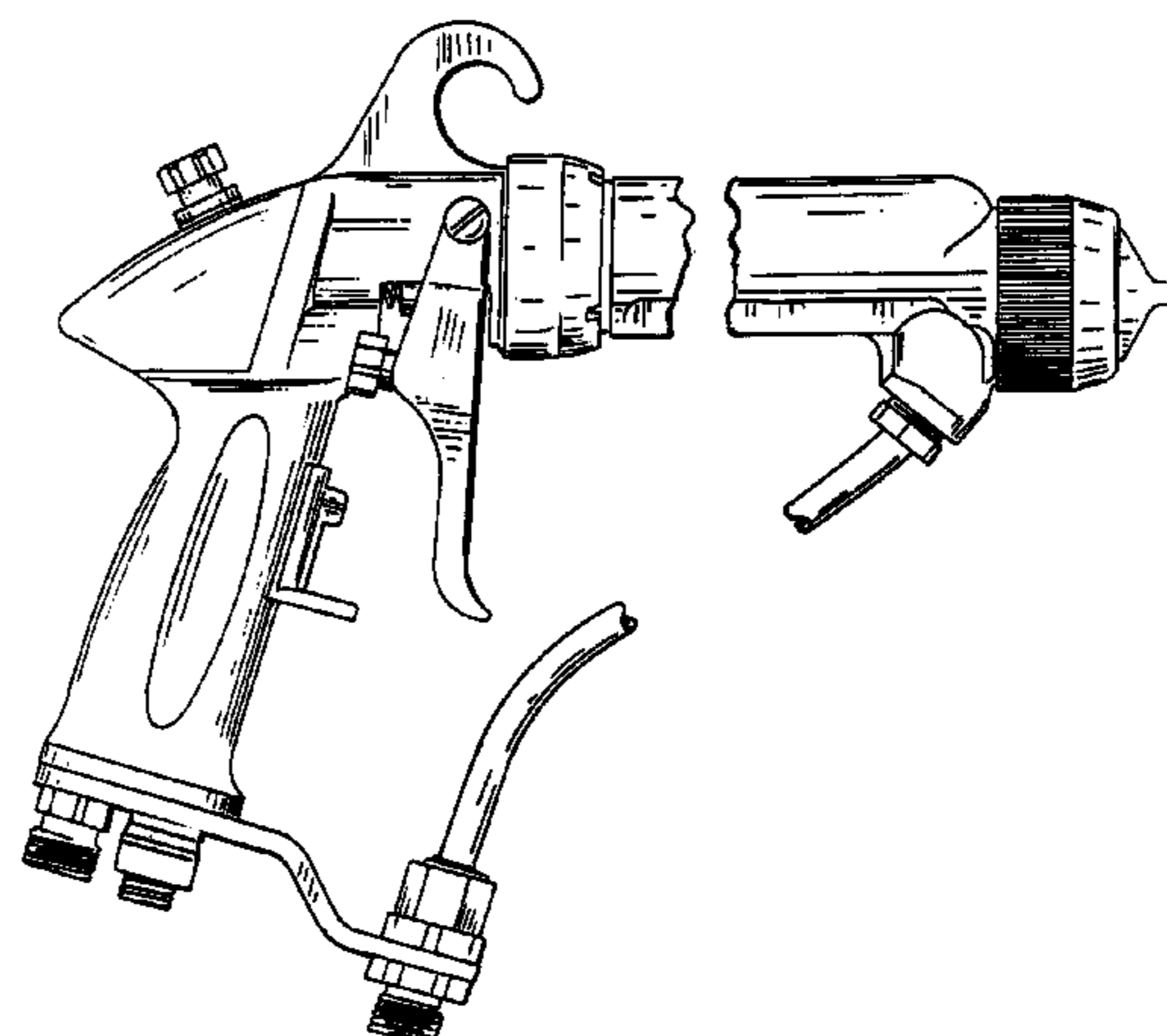
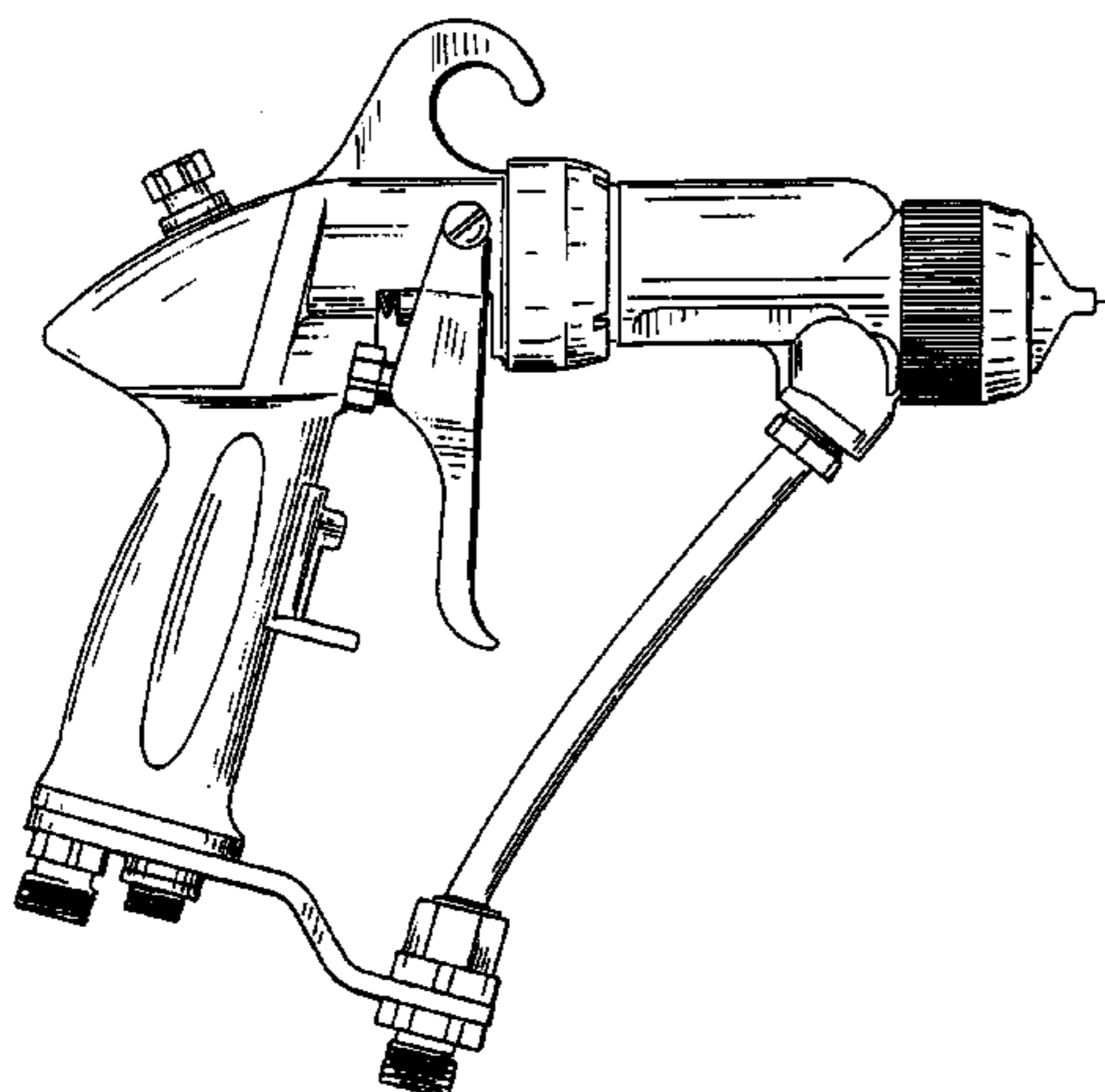

US D545,943 S

U.S. PATENT DOCUMENTS				
		4,606,501 A	8/1986	Bate et al.
3,169,882 A	2/1965	4,613,082 A	9/1986	Gimple et al.
3,169,883 A	2/1965	D287,266 S	12/1986	Knetl et al.
3,265,306 A	8/1966	4,702,420 A	10/1987	Rath
3,567,996 A	3/1971	4,745,520 A	5/1988	Hughey
3,575,344 A	4/1971	4,747,546 A	5/1988	Talacko
3,608,823 A	9/1971	4,759,502 A	7/1988	Pomponi, Jr. et al.
3,610,528 A	10/1971	4,760,962 A	8/1988	Wheeler
3,651,354 A	3/1972	4,770,117 A	9/1988	Hetherington et al.
3,673,463 A	6/1972	4,784,331 A	11/1988	Sharpless et al.
3,687,368 A	8/1972	4,798,340 A	1/1989	Vohringer et al.
3,698,636 A	10/1972	4,802,627 A	2/1989	Moy et al.
3,731,145 A	5/1973	4,811,898 A	3/1989	Murphy
3,791,579 A	2/1974	4,815,666 A	3/1989	Gacka et al.
3,851,618 A	12/1974	4,824,026 A	4/1989	Tamura et al.
3,875,892 A	4/1975	4,844,342 A	7/1989	Foley
3,894,272 A	7/1975	4,844,706 A	7/1989	Katsuyama et al.
3,940,061 A	2/1976	D303,139 S	8/1989	Morgan
3,964,683 A	6/1976	D305,057 S	12/1989	Morgan
3,990,609 A	11/1976	D305,452 S	1/1990	Morgan
3,991,710 A	11/1976	D305,453 S	1/1990	Morgan
4,001,935 A	1/1977	4,911,367 A	3/1990	Lasley
4,002,777 A	1/1977	4,921,172 A	5/1990	Belmain et al.
4,005,825 A	2/1977	4,927,079 A	5/1990	Smith
4,020,393 A	4/1977	4,934,603 A	6/1990	Lasley
4,030,857 A	6/1977	4,934,607 A	6/1990	Lasley
4,037,561 A	7/1977	D313,064 S *	12/1990	Lind et al. D23/226
4,075,677 A	2/1978	4,993,645 A	2/1991	Buschor
4,081,904 A	4/1978	4,995,560 A *	2/1991	Lasley et al. 239/708
4,105,164 A	8/1978	5,022,590 A	6/1991	Buschor
4,114,564 A	9/1978	D318,712 S	7/1991	Buschor
4,116,364 A	9/1978	5,054,687 A	10/1991	Burns et al.
4,133,483 A	1/1979	5,064,119 A	11/1991	Mellette
D252,097 S	6/1979	5,074,466 A	12/1991	Santiago
4,165,022 A	8/1979	5,090,623 A	2/1992	Burns et al.
4,169,545 A	10/1979	D325,241 S	4/1992	Buschor
4,174,070 A	11/1979	5,118,080 A	6/1992	Hartmann
4,174,071 A	11/1979	5,119,992 A	6/1992	Grime
4,187,527 A	2/1980	5,159,544 A	10/1992	Hughey et al.
4,214,709 A	7/1980	5,178,330 A	1/1993	Rodgers
4,216,915 A	8/1980	5,180,104 A	1/1993	Mellette
4,219,865 A	8/1980	5,209,365 A	5/1993	Wood
4,228,961 A	10/1980	5,209,405 A	5/1993	Robinson et al.
4,248,386 A	2/1981	5,219,097 A	6/1993	Huber et al.
4,258,409 A	3/1981	5,236,129 A	8/1993	Grime et al.
4,285,446 A	8/1981	5,261,610 A	11/1993	Waryu et al.
4,290,091 A	9/1981	5,284,299 A	2/1994	Medlock
4,324,812 A	4/1982	5,284,301 A	2/1994	Kieffer
4,331,298 A	5/1982	5,289,974 A	3/1994	Grime et al.
RE30,968 E	6/1982	5,299,740 A	4/1994	Bert
4,361,283 A	11/1982	5,303,865 A	4/1994	Bert
4,380,320 A	4/1983	5,330,108 A	7/1994	Grime et al.
D270,179 S	8/1983	5,332,156 A	7/1994	Wheeler
D270,180 S	8/1983	5,332,159 A	7/1994	Grime et al.
D270,367 S	8/1983	D349,559 S	8/1994	Vanderhoef et al.
D270,368 S	8/1983	D350,387 S *	9/1994	Feitel et al. D23/226
4,401,268 A	8/1983	5,351,887 A	10/1994	Heterington et al.
4,433,003 A	2/1984	5,353,995 A	10/1994	Chabert
4,433,812 A	2/1984	5,395,054 A	3/1995	Wheeler
4,437,614 A	3/1984	5,400,971 A	3/1995	Maugans et al.
4,453,670 A	6/1984	5,482,214 A	1/1996	Talacko
4,481,557 A	11/1984	5,553,788 A	9/1996	Del Gaone et al.
4,483,483 A	11/1984	5,582,347 A	12/1996	Knobbe et al.
4,485,427 A	11/1984	5,582,350 A	12/1996	Kosmyna et al.
4,498,631 A	2/1985	5,584,931 A	12/1996	Buhlmann
RE31,867 E	4/1985	5,618,001 A	4/1997	Del Gaone et al.
4,508,276 A	4/1985	5,632,816 A	5/1997	Allen et al.
4,509,684 A	4/1985	5,639,027 A	6/1997	Fritz
4,513,913 A	4/1985	RE35,769 E	4/1998	Grime et al.
4,529,131 A	7/1985	5,746,831 A	5/1998	Allen et al.
4,537,357 A	8/1985	5,787,928 A	8/1998	Allen et al.
4,574,092 A	3/1986	5,803,313 A	9/1998	Flatt et al.
		5,829,679 A	11/1998	Strong

US D545,943 S

Page 3

5,836,517 A 11/1998 Burns et al.
 5,857,625 A * 1/1999 Klein et al. 239/289
 5,944,045 A 8/1999 Allen et al.
 RE36,378 E 11/1999 Mellette
 5,978,244 A 11/1999 Hughey
 6,012,657 A 1/2000 Knobbe et al.
 6,144,570 A 11/2000 Hughey
 6,179,223 B1 1/2001 Sherman et al.
 6,189,809 B1 2/2001 Schwebemeyer
 6,276,616 B1 8/2001 Jenkins
 6,276,618 B1 8/2001 Yanagida et al.
 D457,599 S * 5/2002 Karwoski et al. D23/226
 6,402,058 B2 6/2002 Kaneko et al.
 6,423,142 B1 7/2002 Hughey
 6,425,533 B1 7/2002 Shilton et al.
 6,460,787 B1 10/2002 Hartle et al.
 6,562,137 B2 5/2003 Hughey
 6,572,029 B1 6/2003 Holt
 6,644,295 B2 11/2003 Jones
 6,669,112 B2 12/2003 Reetz, III et al.
 6,676,049 B2 1/2004 van der Steur
 6,698,670 B1 3/2004 Gosis et al.
 6,712,292 B1 3/2004 Gosis et al.
 6,854,672 B2 2/2005 Allen
 6,916,023 B2 7/2005 Alexander et al.
 2003/0006322 A1 1/2003 Hartle et al.
 2003/0197078 A1 10/2003 Mauchle et al.
 2004/0050867 A1 3/2004 Alexander et al.
 2004/0061007 A1 4/2004 Milojevic et al.
 2004/0256503 A1 12/2004 Young, II et al.
 2005/0023385 A1 2/2005 Kwok et al.
 2005/0035229 A1 2/2005 Zhu et al.

2005/0173556 A1 8/2005 Kwok et al.

FOREIGN PATENT DOCUMENTS

FR	1274814	9/1961
GB	1 209 653	10/1970
GB	1 387 632	3/1975
JP	58-124560	7/1983
JP	60-151554	8/1985
JP	1-315361	12/1989
JP	3-169361	7/1991
JP	3-221166	9/1991
JP	6-94166	4/1994
JP	9-220500	8/1997
WO	WO 94/13404	6/1994
WO	WO 03/031075 A1	4/2003

OTHER PUBLICATIONS

“REA-90A and REA-90LA Automatic Electrostatic Spray Guns Dual Atomization Technology” Service Instruction, ITW Ransburg Electrostatic Systems, 2004 Illinois Tool Works Inc.
 “REA-70 and REA-70L Electrostatic Spray Guns Dual Atomization Technology” Service Manual, Ransburg, 2005 Illinois Tool Works Inc.
 “REA-III and REA-III L Delta Electrostatic Spray Guns Dual Atomization Technology” Service Instruction, ITW Ransburg Electrostatic Systems, 2004 Illinois Tool Works Inc.
 “REA-IV and REA-IV L Delta Electrostatic Spray Guns Dual Atomization Technology”, Service Instruction, ITW Ransburg Electrostatic Systems, 2003 Illinois Tool Works Inc.
 “M90 Handguns” Service Manual, Ransburg, 2005 Illinois Tool Works Inc.

* cited by examiner

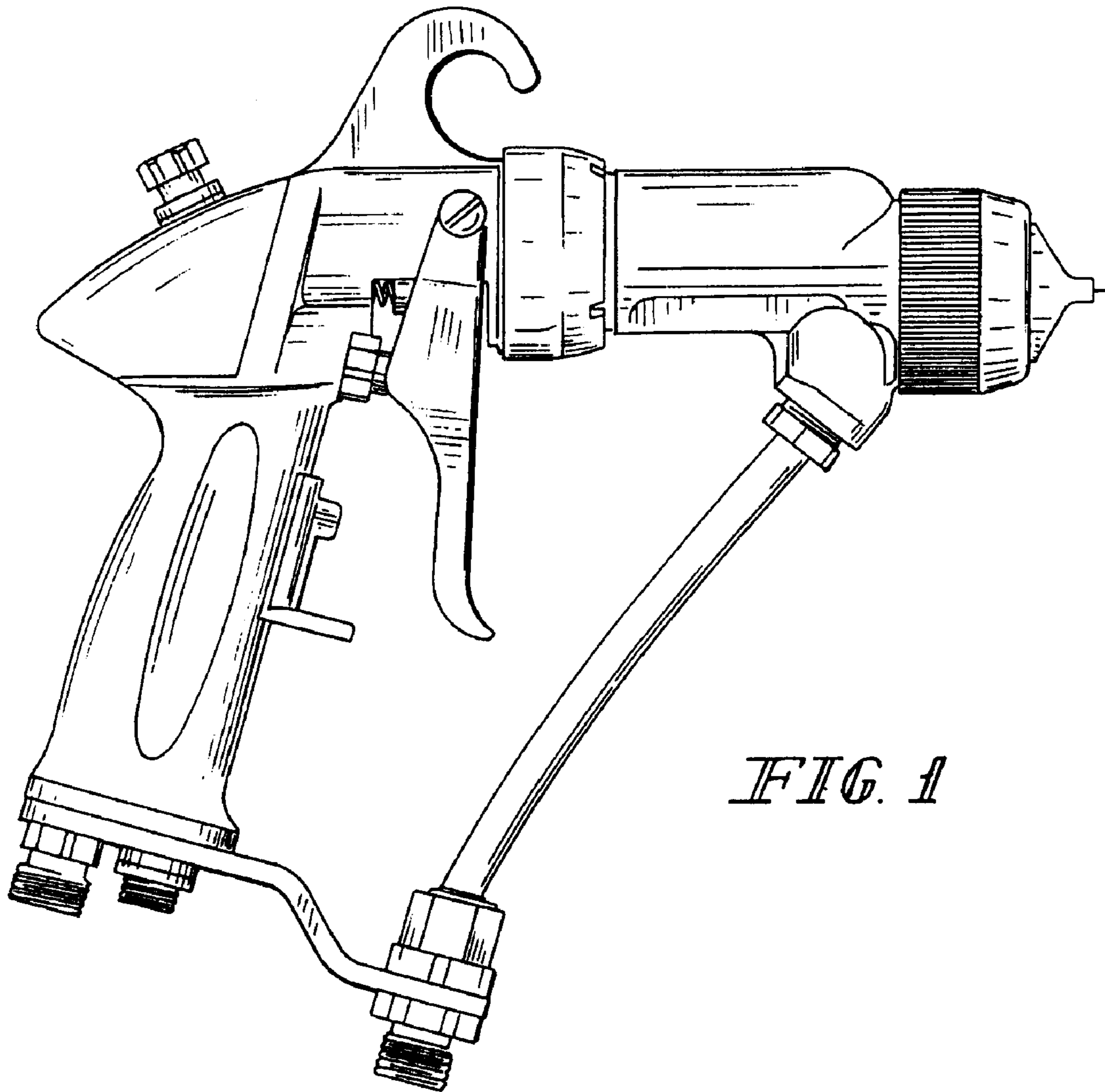

FIG. 1

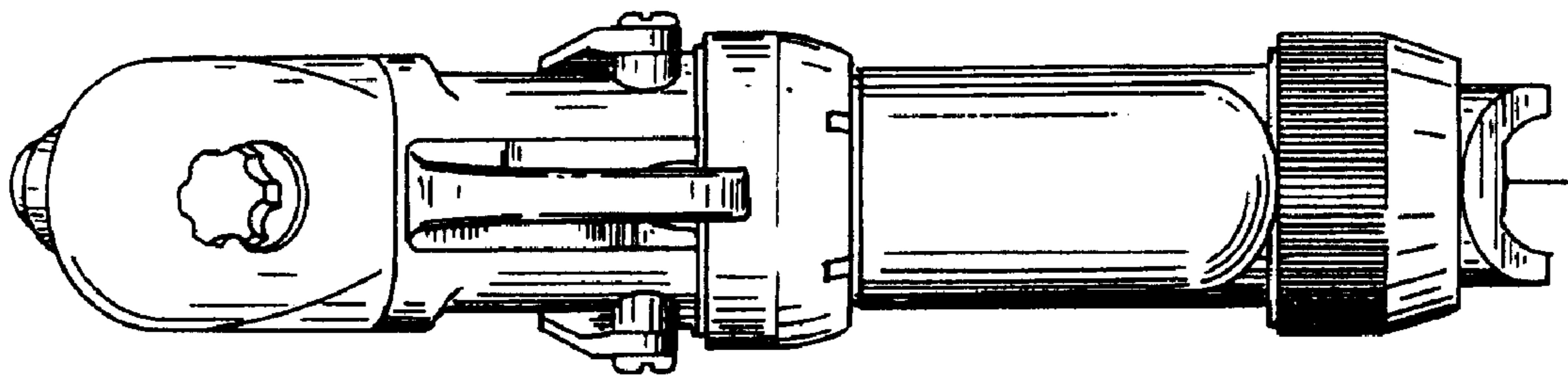

FIG. 2

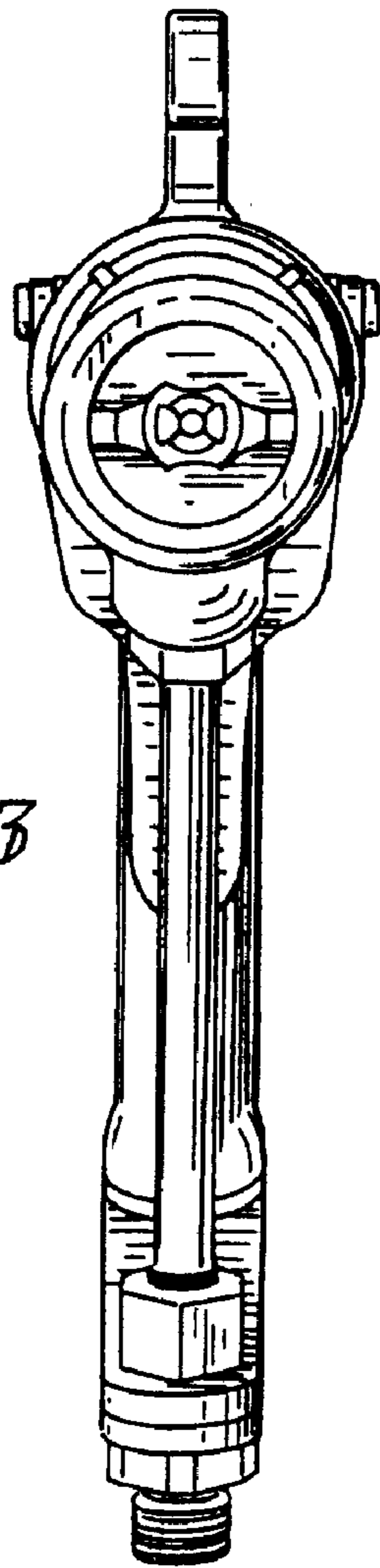

FIG. 3

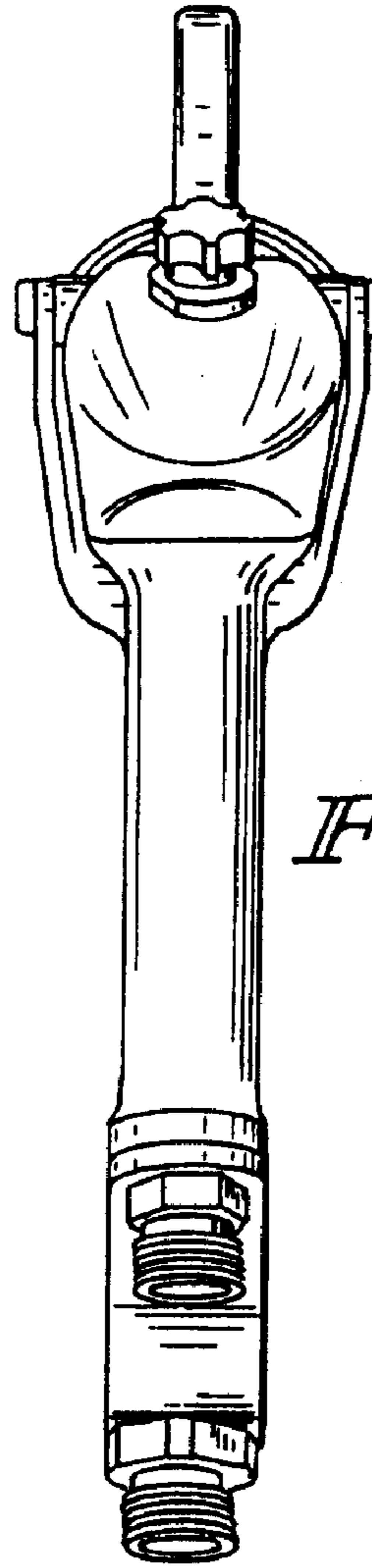

FIG. 4

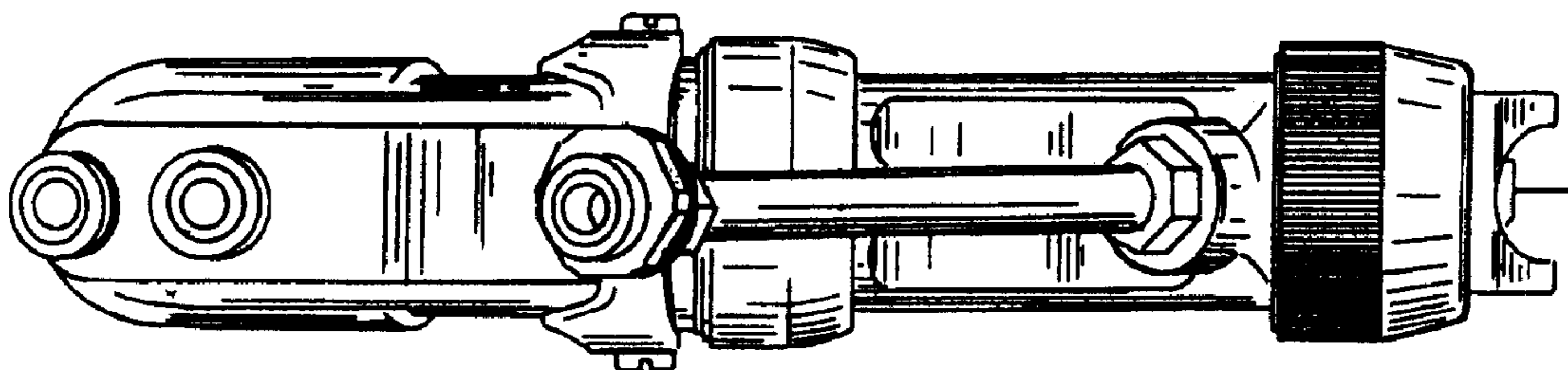

FIG. 5

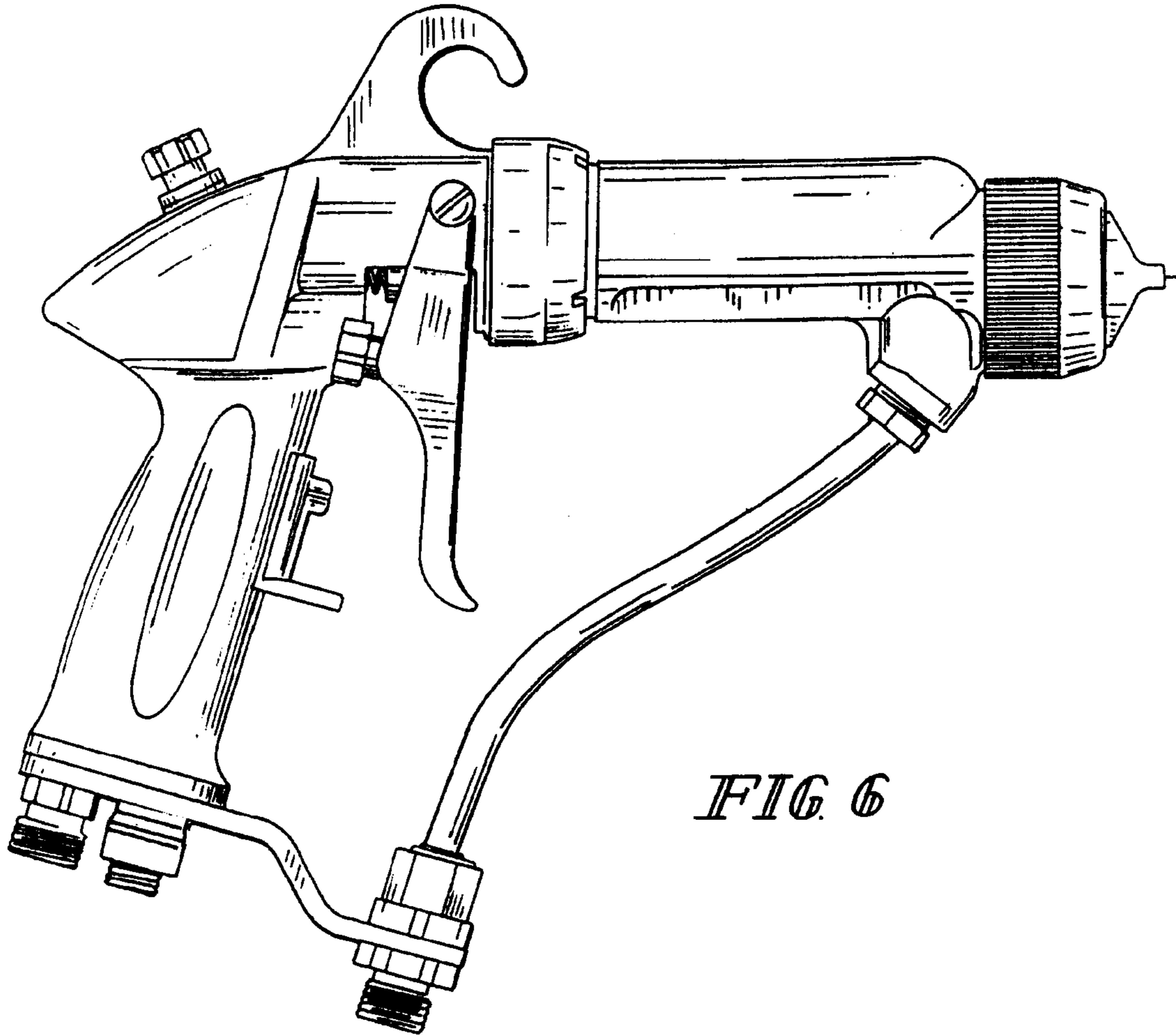

FIG. 6

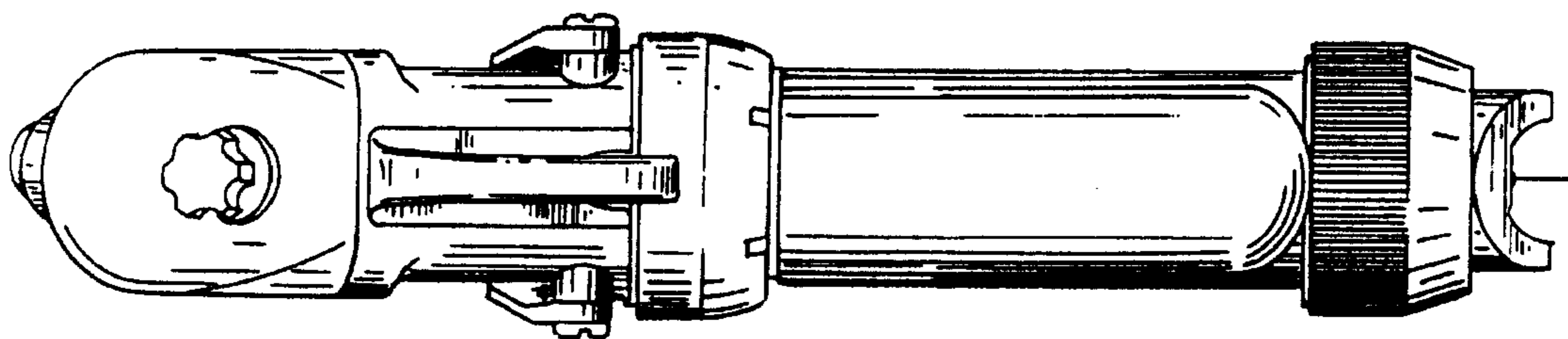

FIG. 7

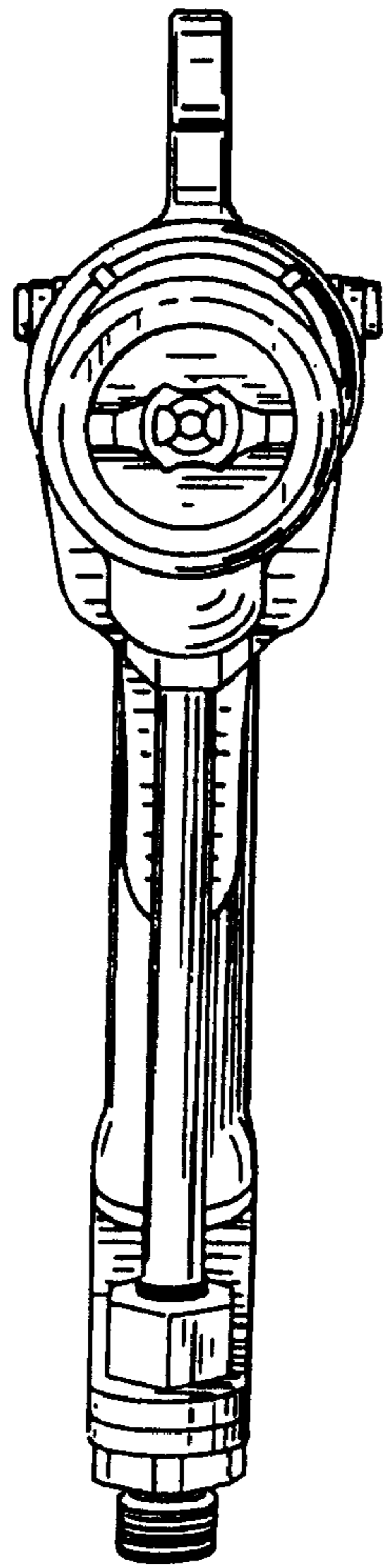

FIG. 8

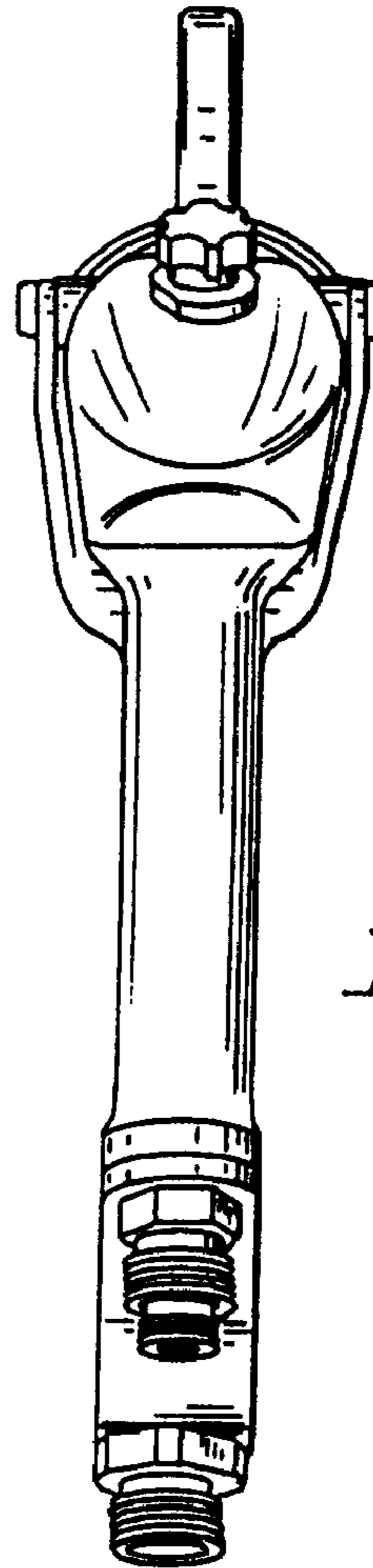

FIG. 9

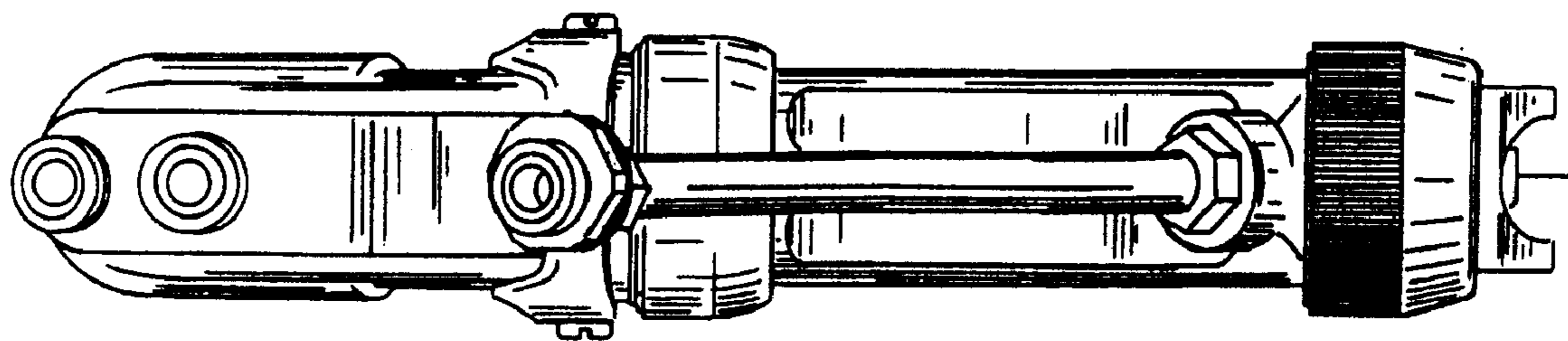

FIG. 10

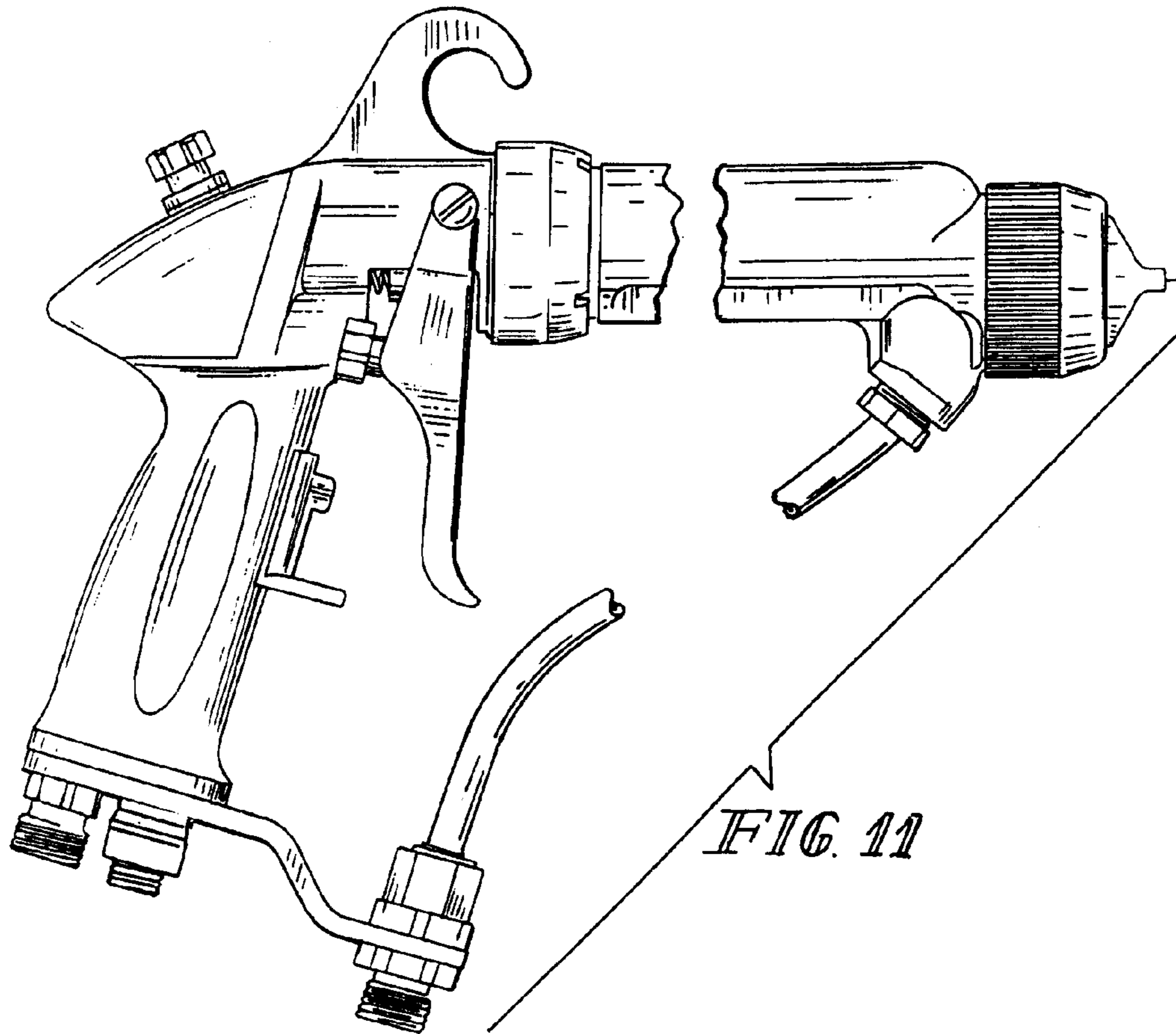

FIG. 11

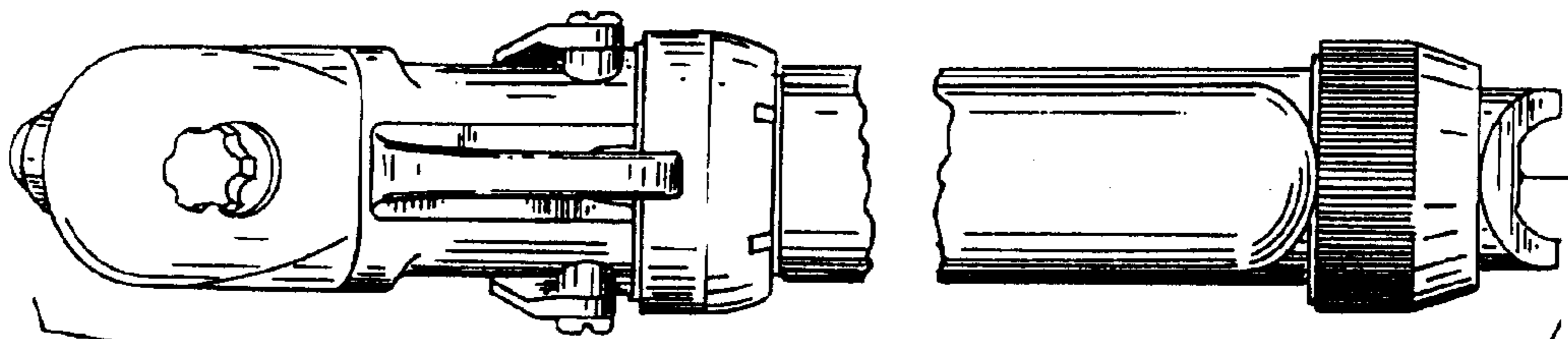

FIG. 12

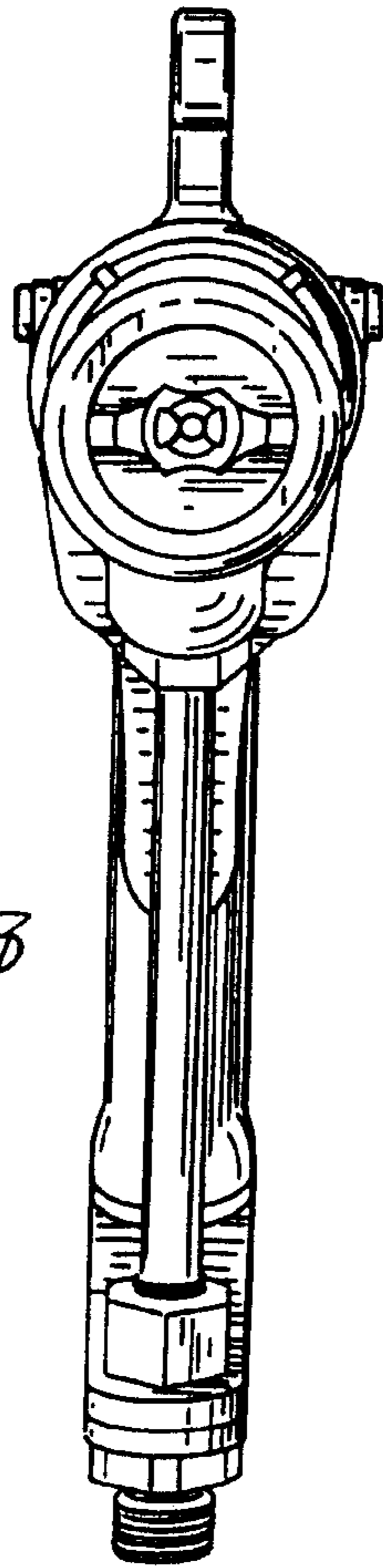

FIG. 13

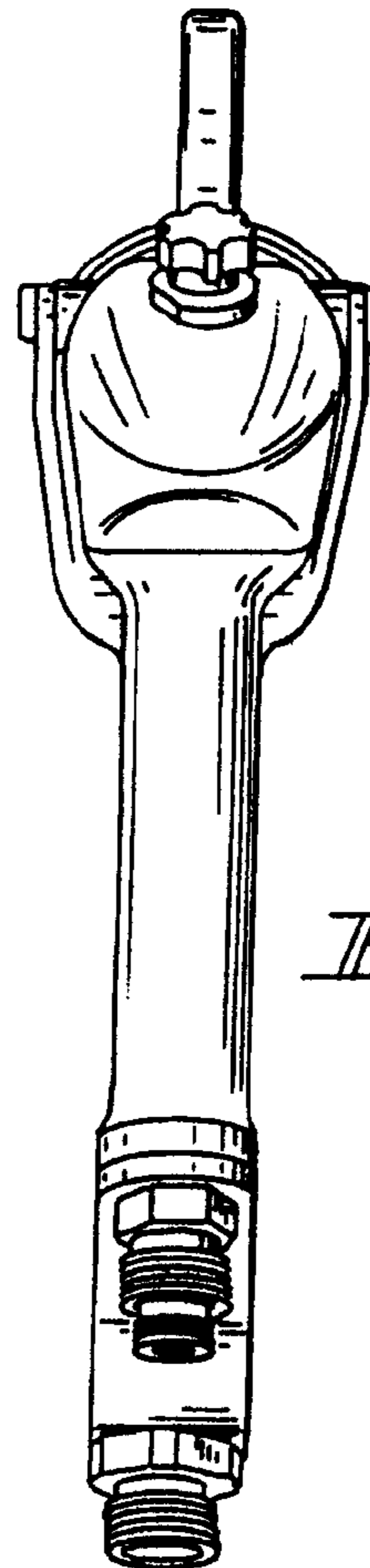

FIG. 14

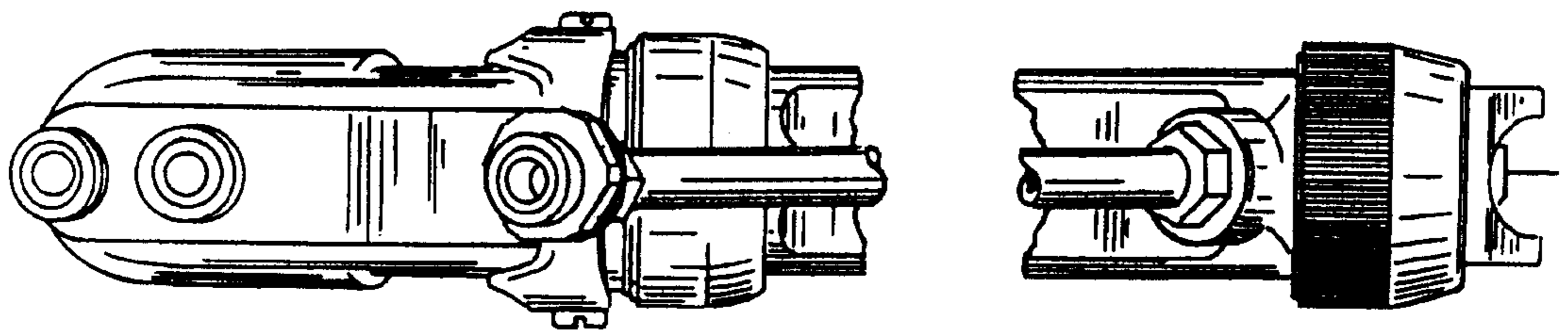

FIG. 15