



US00D545925S

(12) **United States Design Patent**
Milner

(10) **Patent No.:** **US D545,925 S**

(45) **Date of Patent:** **** Jul. 3, 2007**

(54) **FLYING AUTOMOBILE**

(57) **CLAIM**

(76) Inventor: **James R. Milner**, 16101 SE. Evergreen Hwy., Vancouver, WA (US) 98683

The ornamental design for a flying automobile, as shown and described.

(**) Term: **14 Years**

DESCRIPTION

(21) Appl. No.: **29/267,552**

FIG. 1 is a perspective view of a flying automobile showing my new design with the wings, canard and wheel structures disposed in folded and retracted condition for road travel operation of the flying automobile of this design.

(22) Filed: **Oct. 16, 2006**

FIG. 2 is a right side elevational view of the automobile of FIG. 1.

(51) **LOC (8) Cl.** **21-01**

FIG. 3 is a left side elevational view thereof.

(52) **U.S. Cl.** **D21/533**

FIG. 4 is a top plan view as viewed from the top in FIG. 2.

(58) **Field of Classification Search** D21/447, D21/448, 450, 533, 548-551, 562; D12/82, D12/83, 86, 88, 91-93; 446/93, 95, 230, 446/232, 431, 454-456, 465-471; 296/181.1, 296/181.2

FIG. 5 is a front end elevational view taken from the right in FIG. 2.

See application file for complete search history.

FIG. 6 is a rear end elevational view taken from the left in FIG. 2.

FIG. 7 is a bottom plan view thereof.

(56) **References Cited**

U.S. PATENT DOCUMENTS

2,562,490	A *	7/1951	Hall	244/2
2,791,867	A *	5/1957	Dasher	446/95
D328,110	S *	7/1992	Barker et al.	D21/550
D337,626	S *	7/1993	Chen	D21/549
D352,532	S *	11/1994	Tully	D21/533
D359,082	S *	6/1995	Aker et al.	D21/550

FIG. 8 is a perspective view of the flying automobile of FIGS. 1-8 but showing the automobile with the wings, canard and wheel structures deployed in unfolded and extended condition for flying operation of the flying automobile of this design.

FIG. 9 is a right side elevational view of the vehicle of FIG. 8.

FIG. 10 is a left side elevational view thereof.

FIG. 11 is a top plan view as viewed from the top in FIG. 9.

FIG. 12 is a front end elevational view taken from the right in FIG. 9.

* cited by examiner

FIG. 13 is a rear end elevational view taken from the left in FIG. 9; and,

FIG. 14 is a bottom plan view thereof.

Primary Examiner—Holly H. Baynham

Assistant Examiner—Cynthia M. Chin

(74) *Attorney, Agent, or Firm*—Olson & Olson

1 Claim, 11 Drawing Sheets

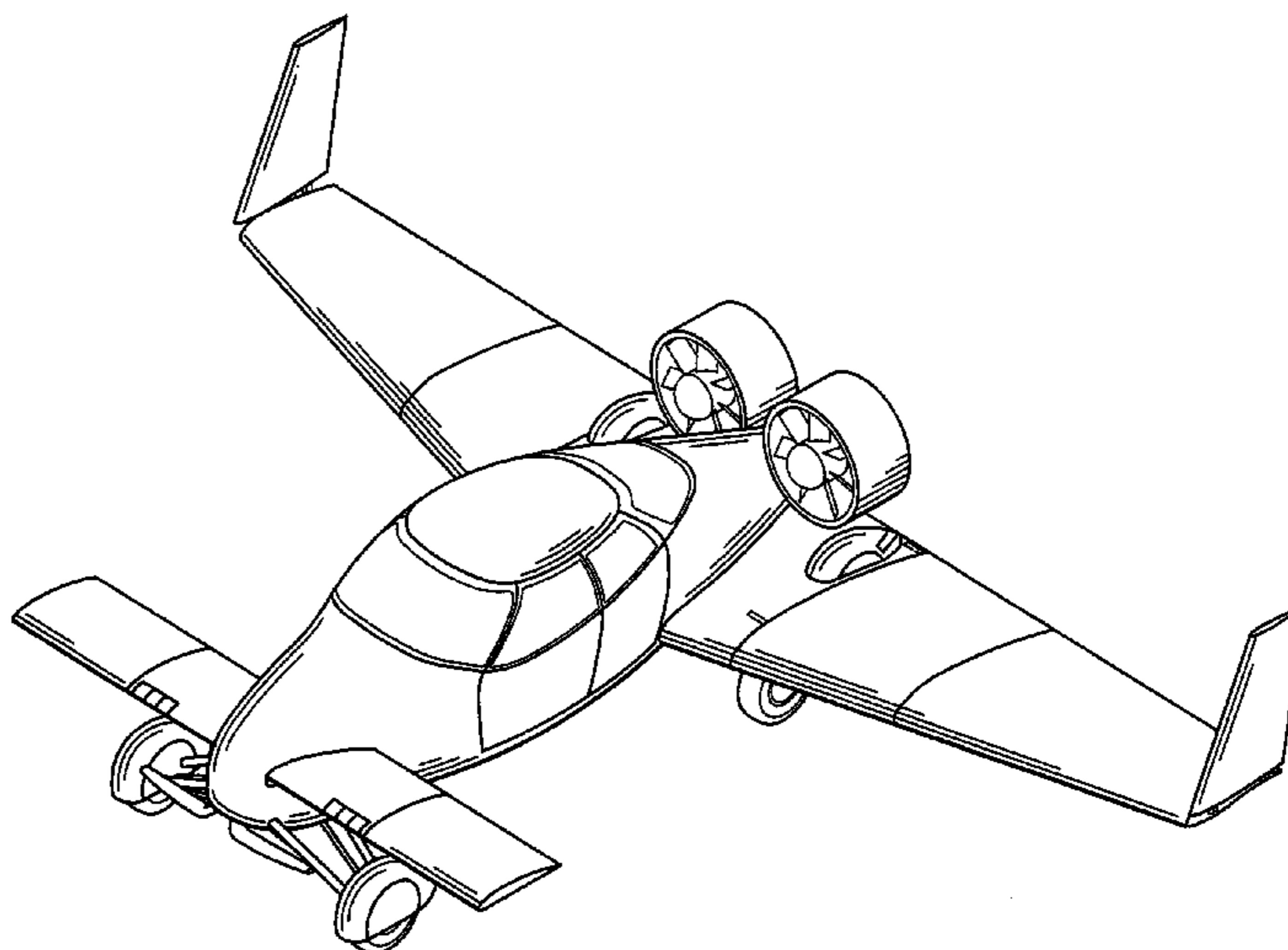
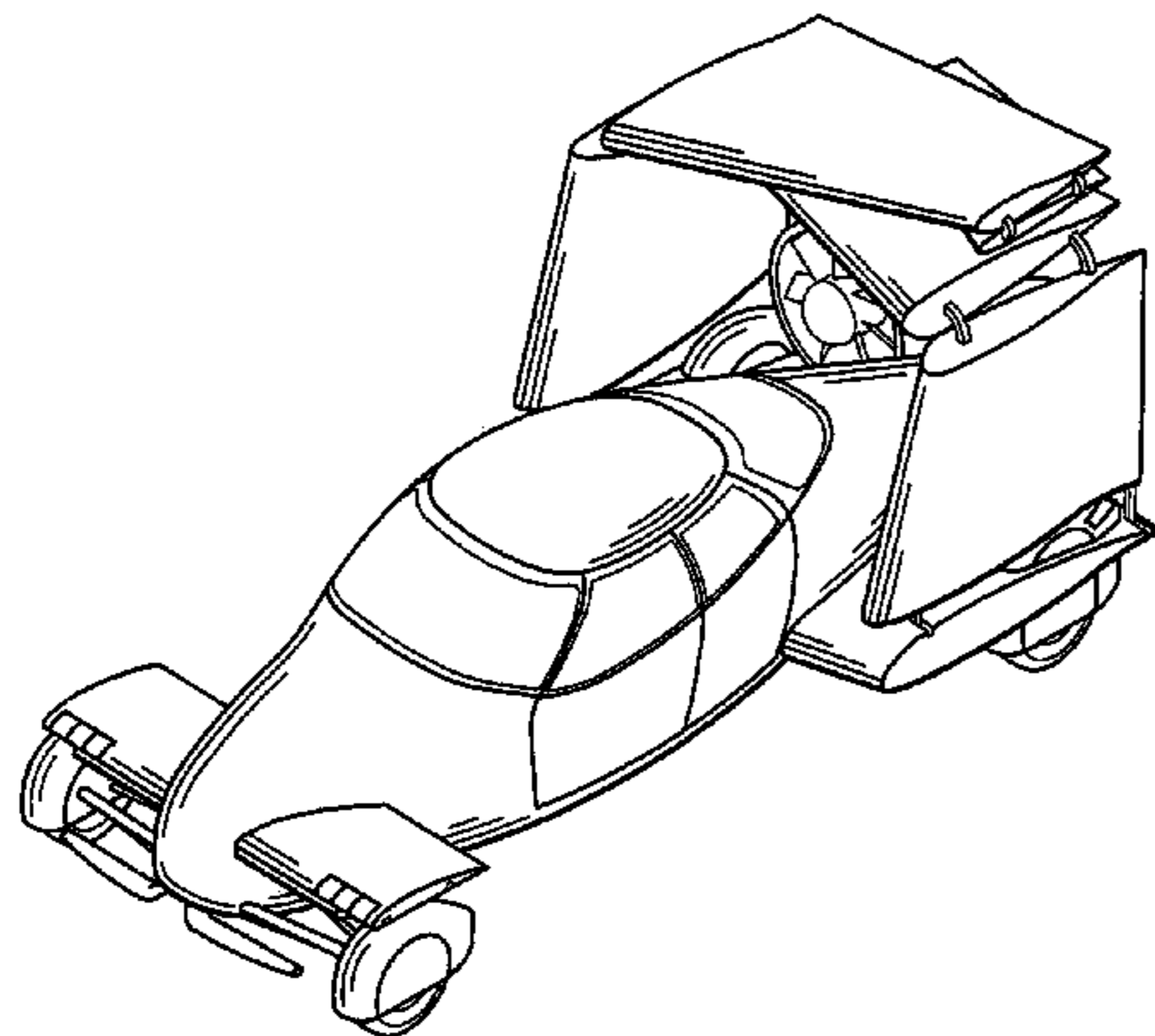

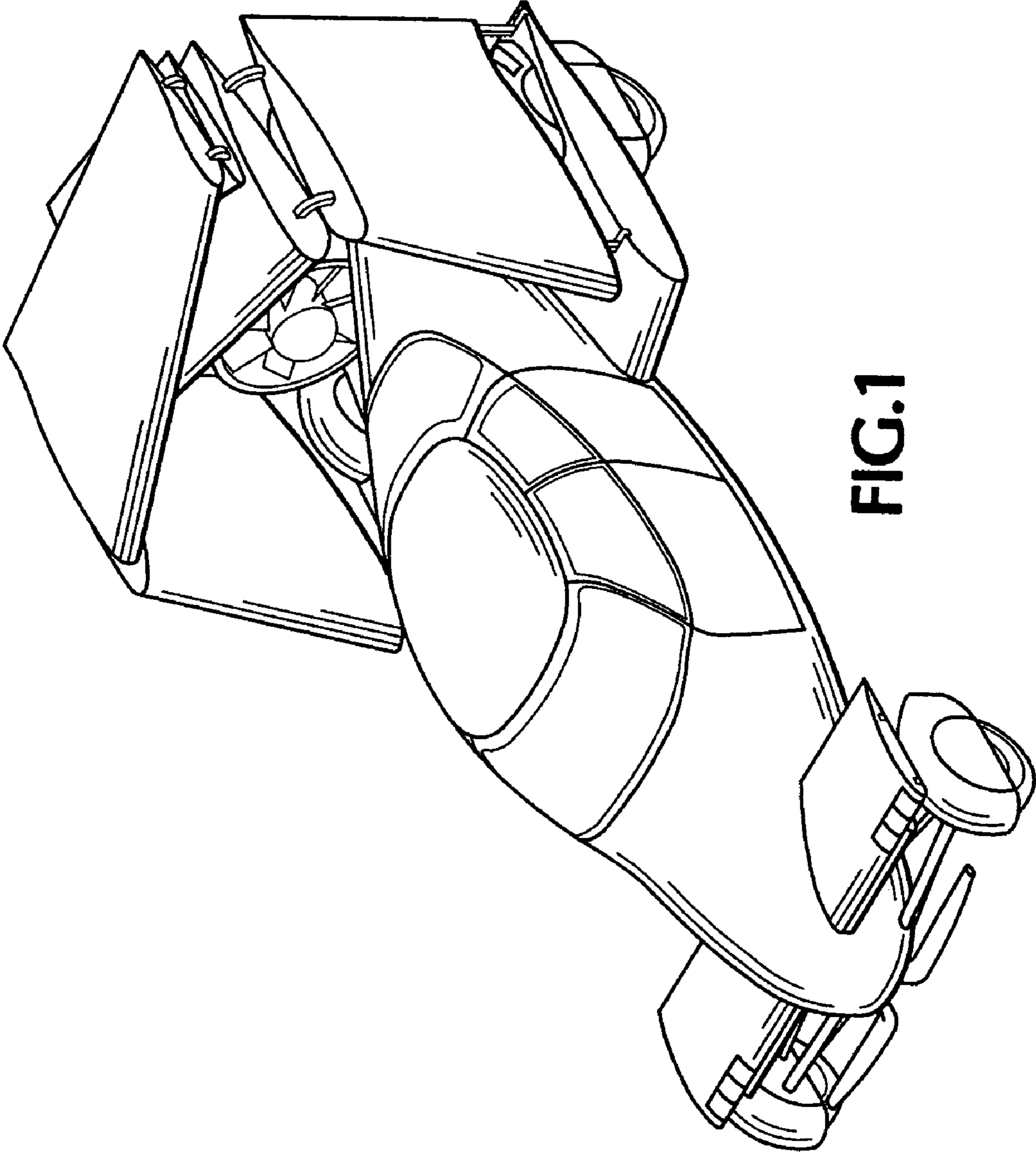

FIG. 1

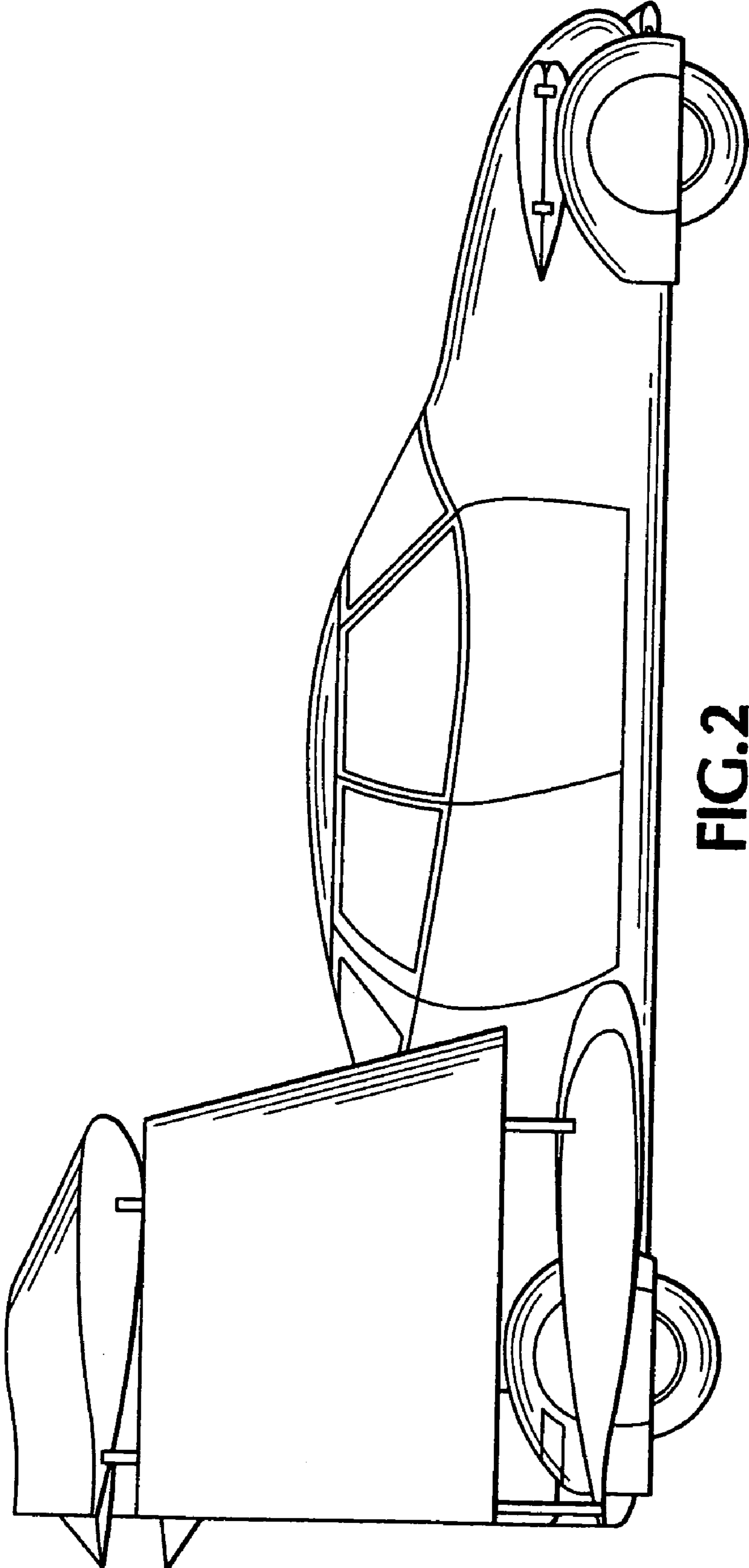

FIG. 2

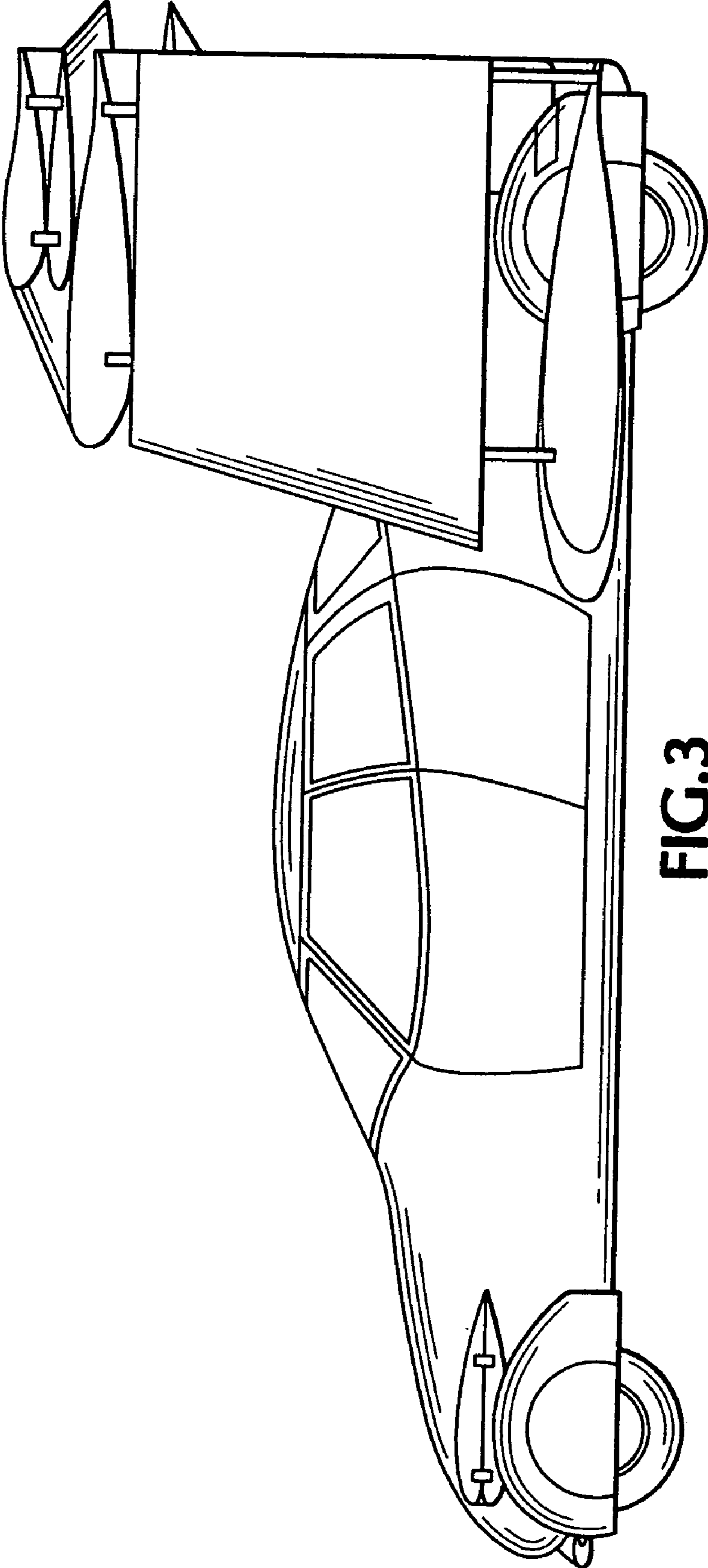

FIG.3

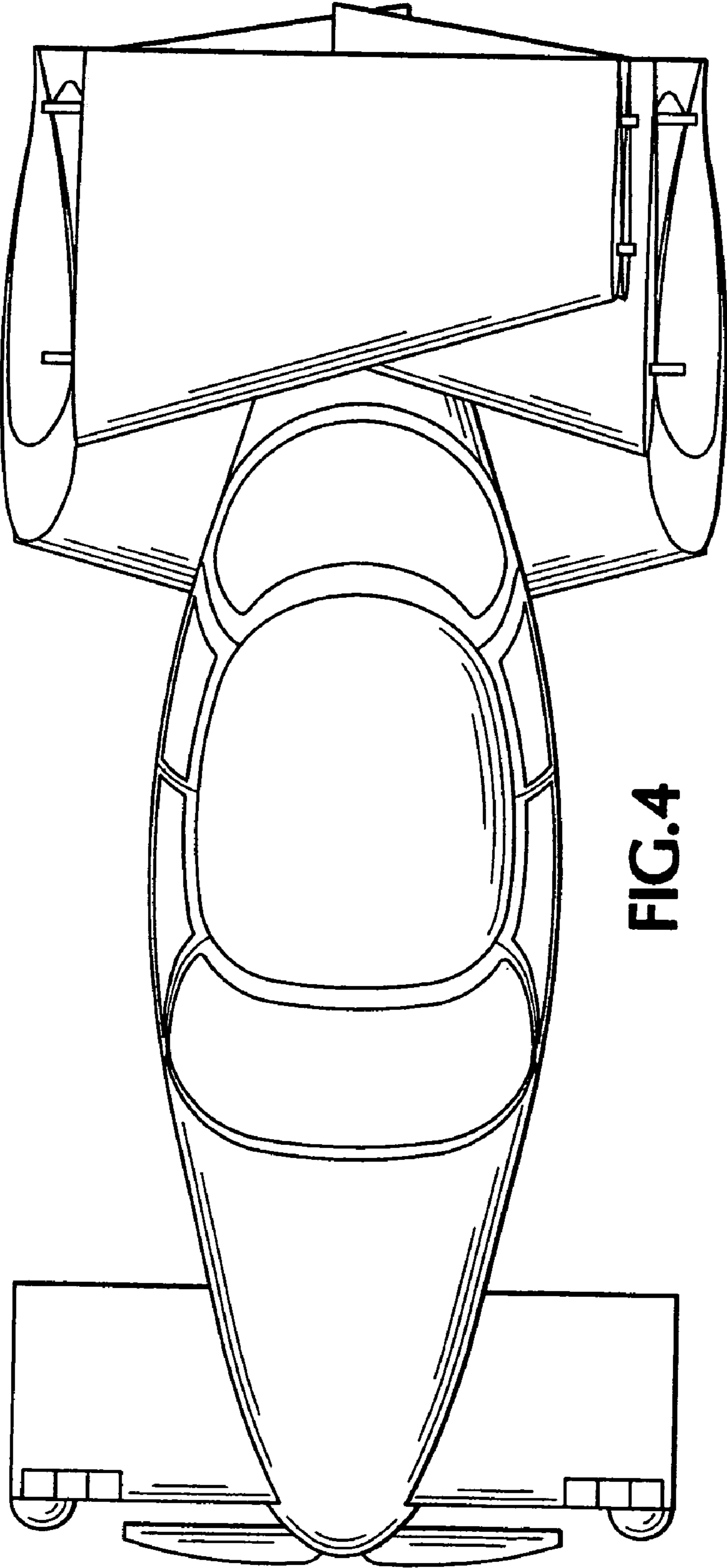

FIG. 4

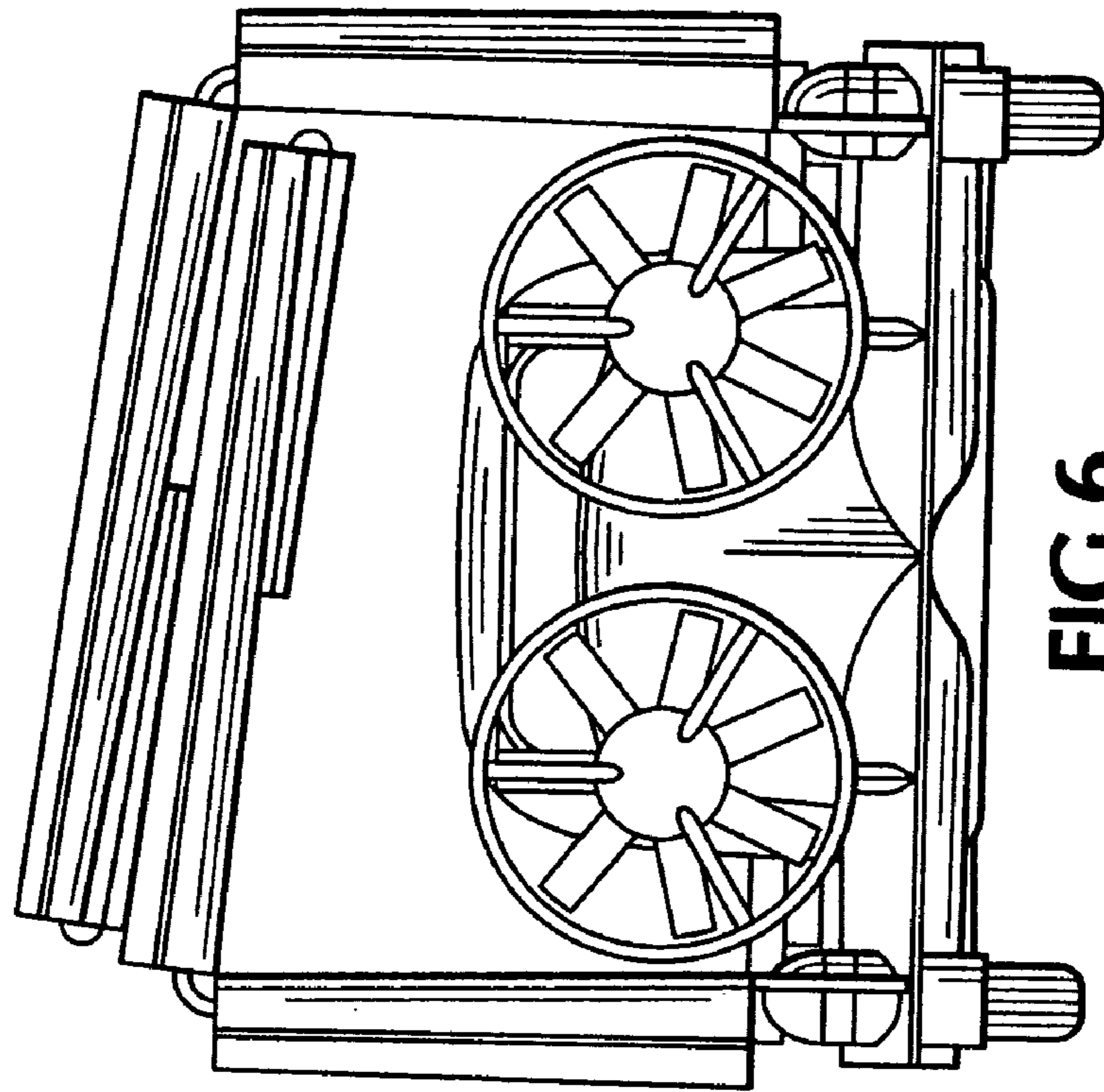

FIG.6

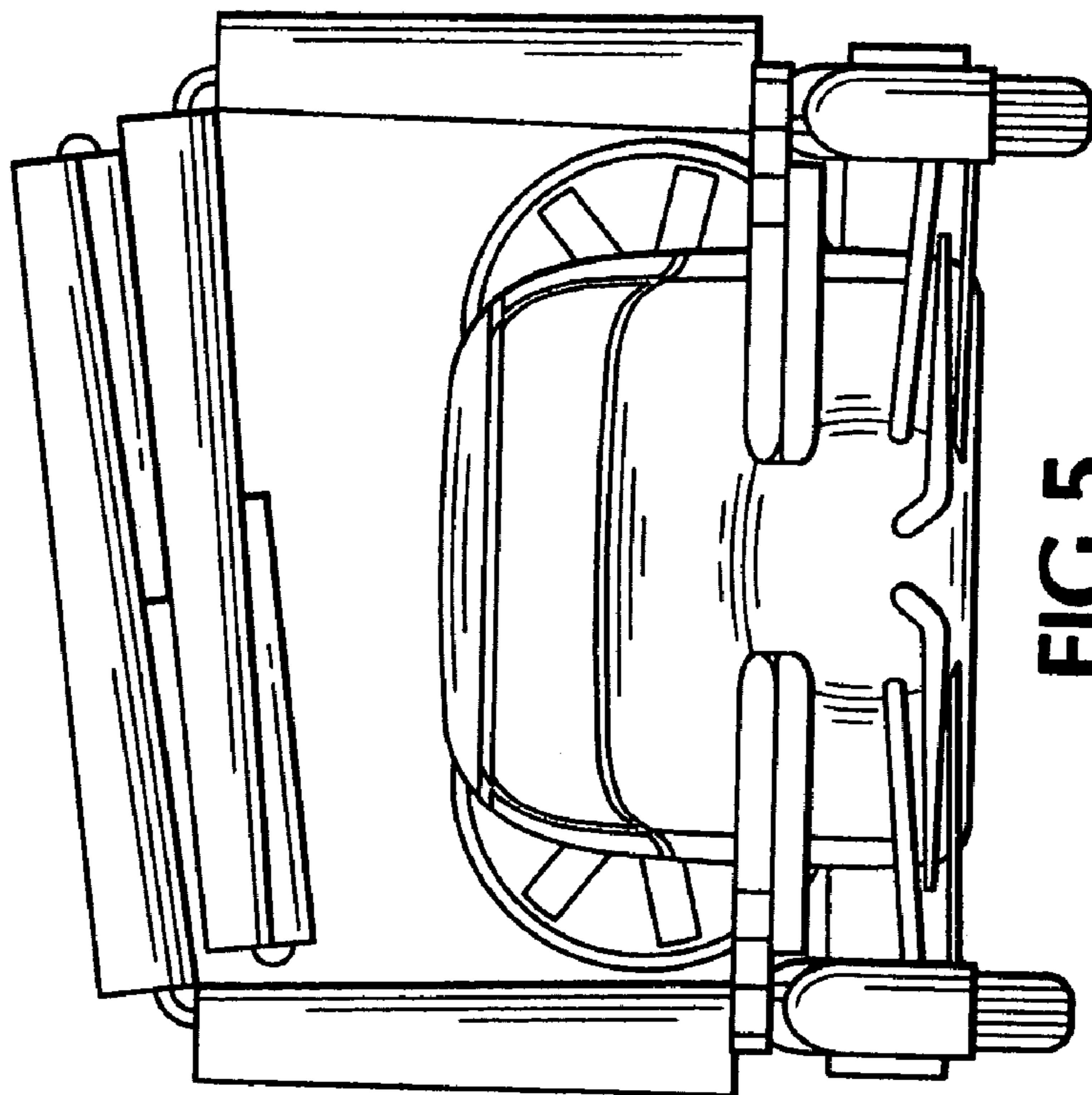

FIG.5

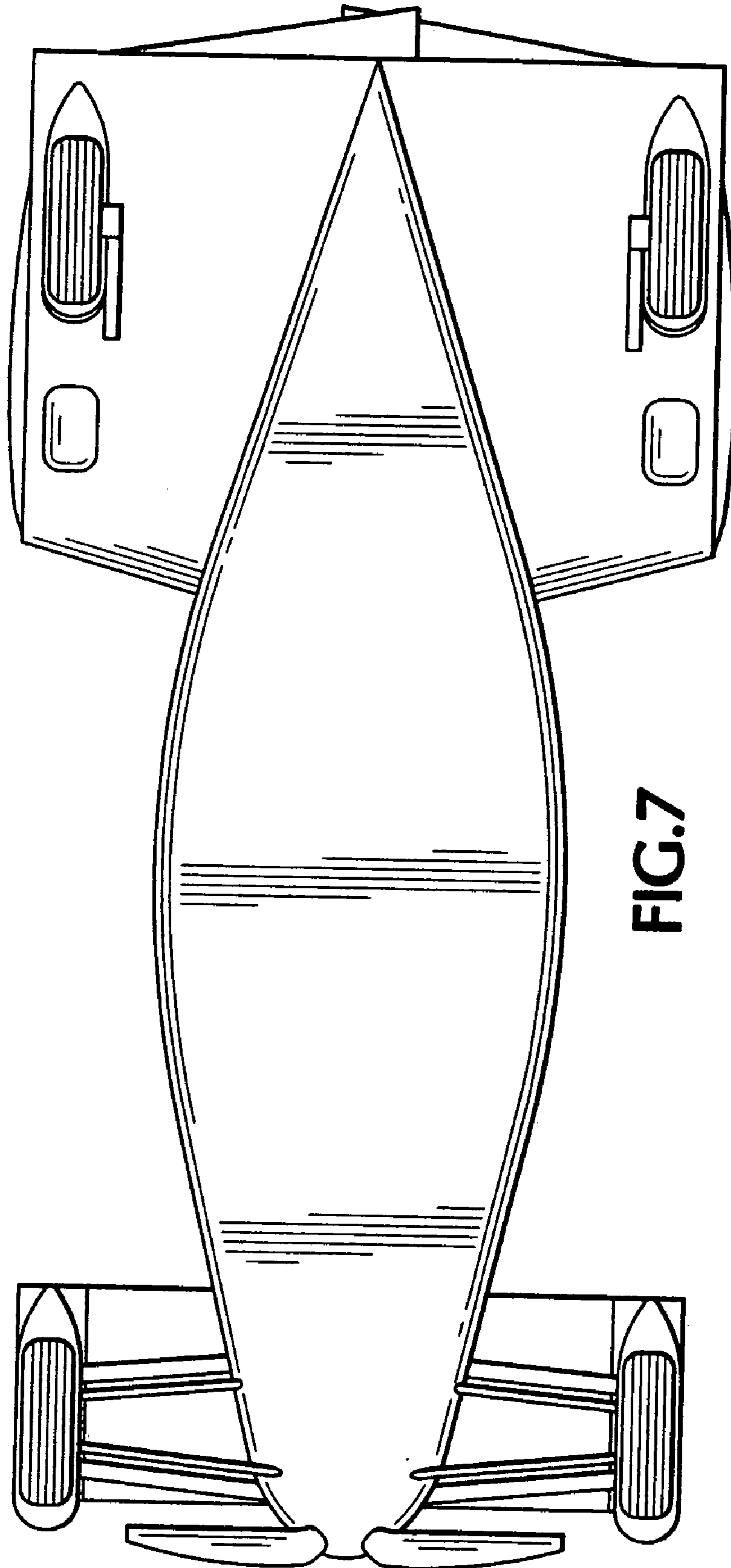

FIG.7

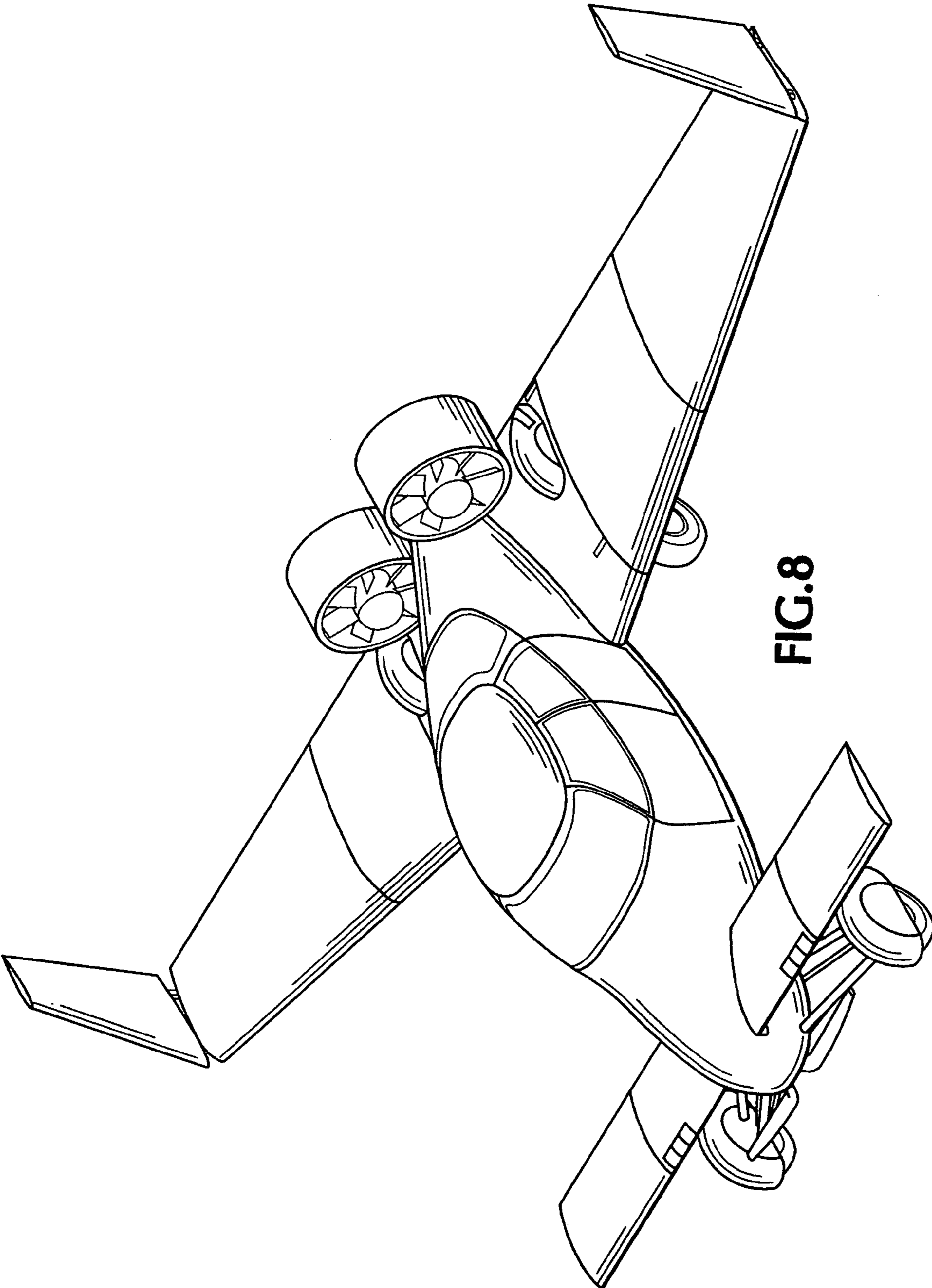
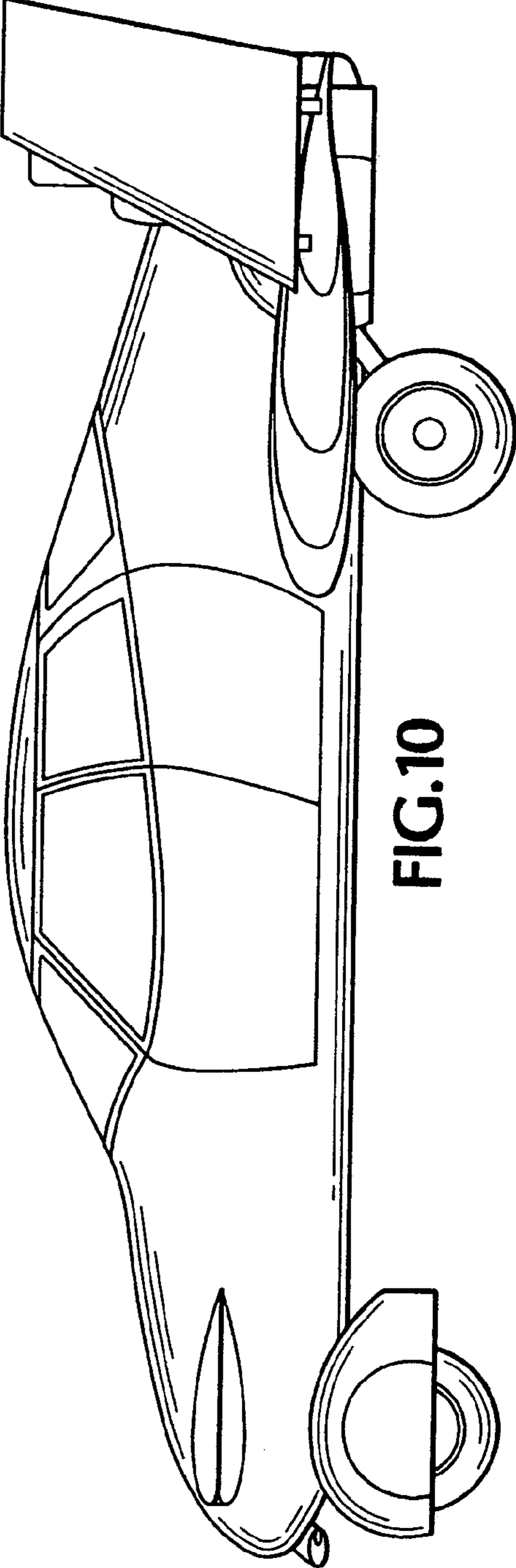
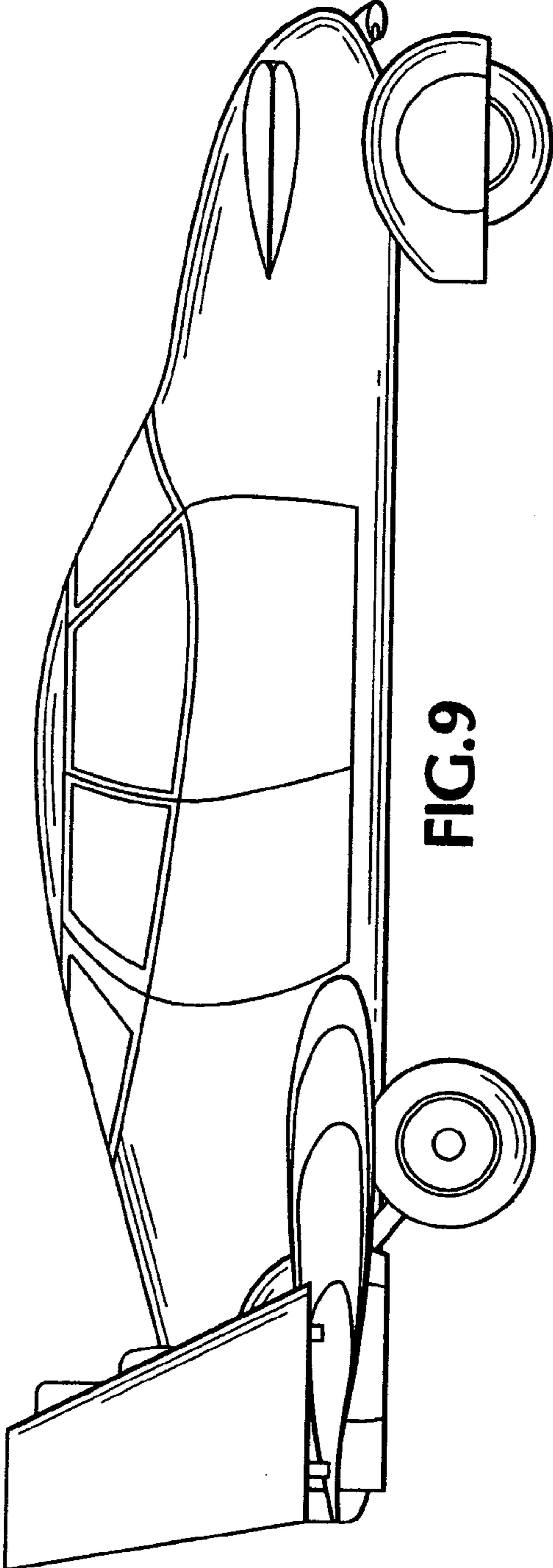

FIG. 8



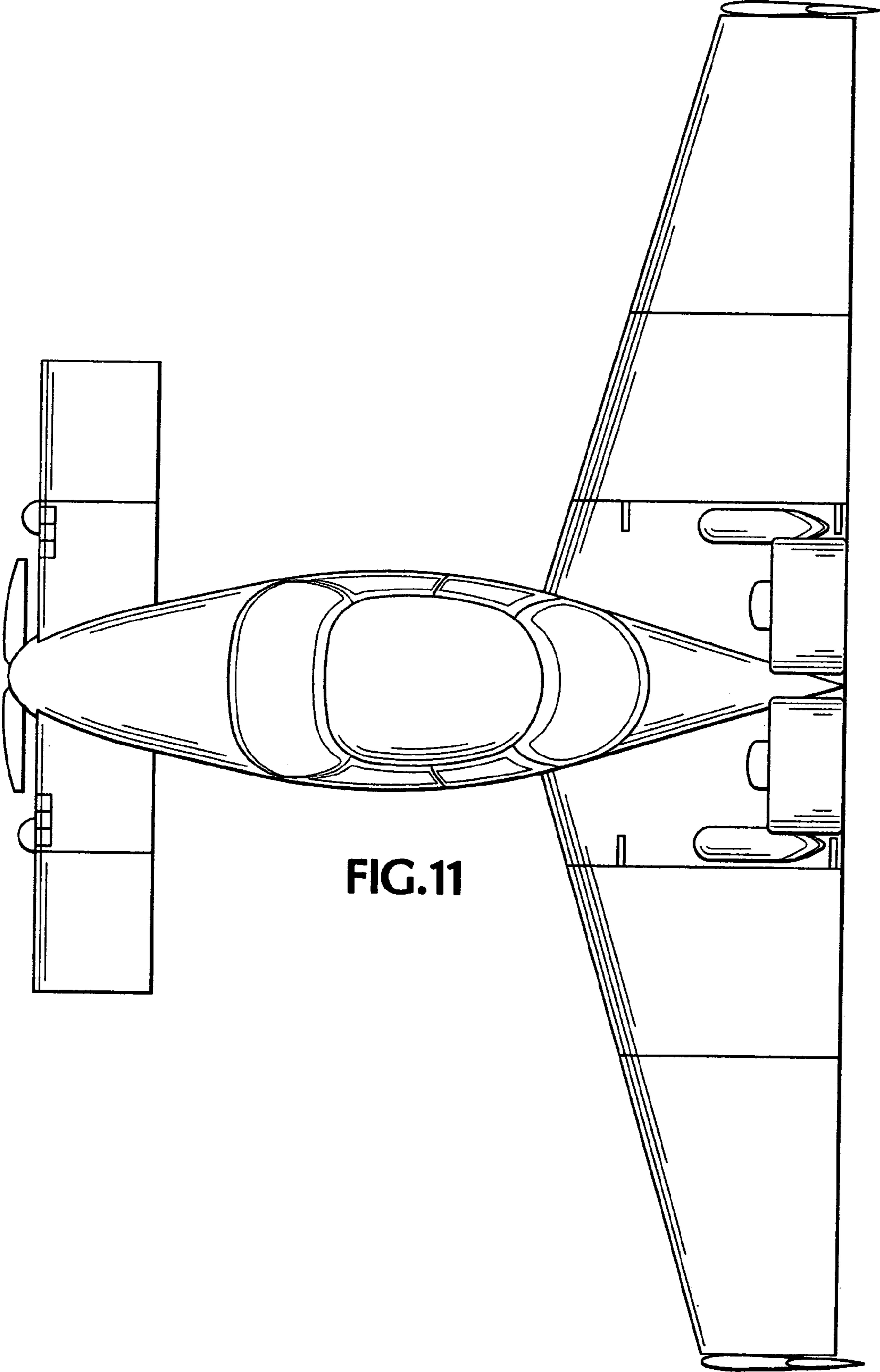

FIG.11

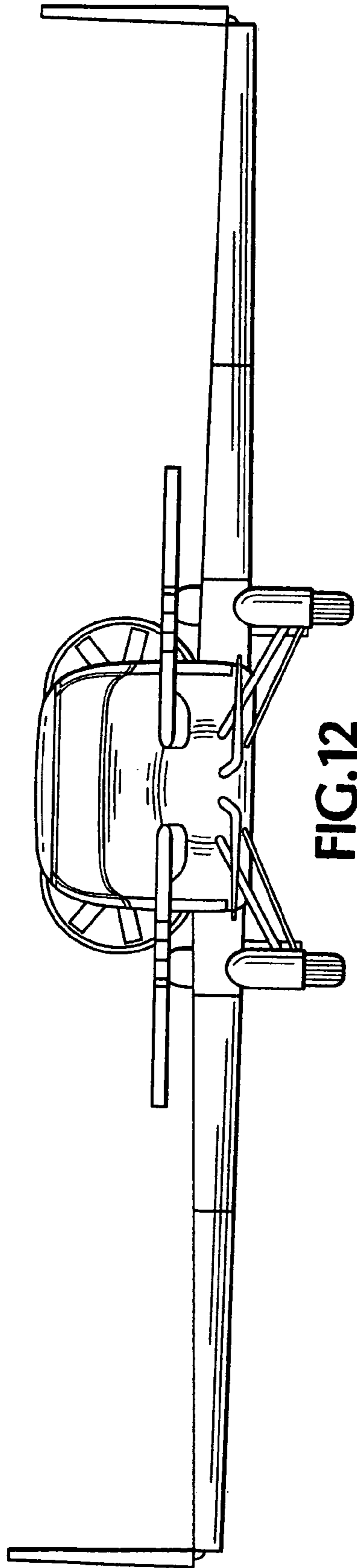

FIG. 12

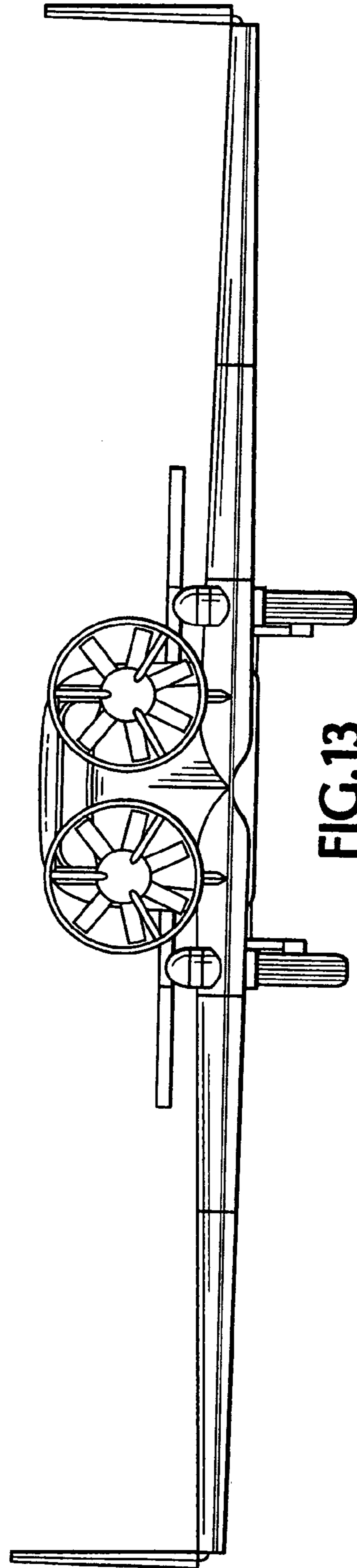

FIG. 13

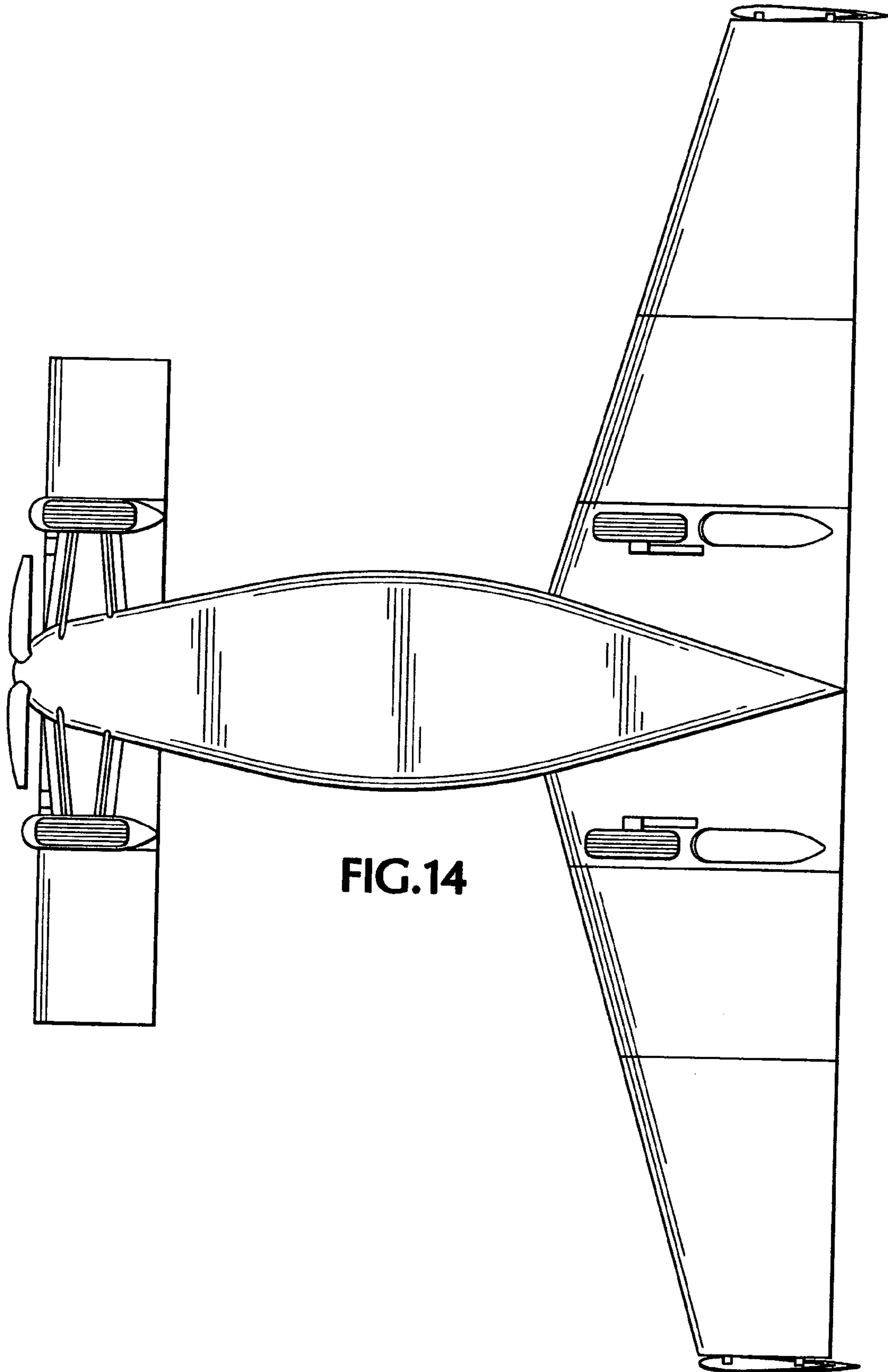

FIG.14