

US00D545740S

(12) **United States Design Patent**
Schiavone et al.

(10) **Patent No.:** **US D545,740 S**

(45) **Date of Patent:** **** Jul. 3, 2007**

(54) **VEHICLE MIRROR**

(75) Inventors: **Patrick Schiavone**, Bloomfield, MI (US); **Gordon Platto**, Troy, MI (US); **Michael Smith**, Plymouth, MI (US); **Albert Debusschere**, Brighton, MI (US)

(73) Assignee: **Ford Global Technologies, LLC**, Dearborn, MI (US)

(**) Term: **14 Years**

(21) Appl. No.: **29/246,020**

(22) Filed: **Dec. 21, 2005**

(51) **LOC (8) Cl.** **12-16**

(52) **U.S. Cl.** **D12/187**

(58) **Field of Classification Search** D12/187-189;
359/838-851, 855-868, 871-881, 507; 248/475.1,
248/476, 480-481, 485-487

See application file for complete search history.

(56) **References Cited**

U.S. PATENT DOCUMENTS

4,585,316 A *	4/1986	Knutson et al.	359/507
D350,721 S *	9/1994	Dayton et al.	D12/187
D427,127 S *	6/2000	Horowitz	D12/187
D432,473 S *	10/2000	Sieber	D12/187
D449,262 S *	10/2001	Kuo	D12/187
D455,689 S *	4/2002	Englander	D12/187
D479,169 S *	9/2003	Schmidt et al.	D12/187
D485,521 S *	1/2004	Kuo	D12/187
D490,351 S *	5/2004	Wang	D12/187
D491,501 S *	6/2004	Kuo	D12/187
D505,897 S *	6/2005	Wade	D12/188
D517,464 S *	3/2006	McCutcheon et al.	D12/187
D519,071 S *	4/2006	Moruzzi	D12/187

OTHER PUBLICATIONS

Pickup Truck.com, *Caught! 2005 Ford F-350 Super Duty*, Aug. 4, 2003, <http://www.pickuptruck.com/html/2005/ford/superduty/caught.html>.

Automotive News Online, *Ford modifies '05 F-series Super Duty pickups*, May 24, 2004, <http://www.autonews.com/article.cms?articleid=48362>.

(Continued)

Primary Examiner—Stacia Cadmus
(74) *Attorney, Agent, or Firm*—Damian Porcari

(57) **CLAIM**

The ornamental design for a vehicle mirror, as shown and described.

DESCRIPTION

FIG. 1 is a frontal orthographic view of a left vehicle mirror; FIG. 2 is a front view of the left vehicle mirror; FIG. 3 is a left side elevational view of the left vehicle mirror; FIG. 4 is a top down plan view of the left vehicle mirror; FIG. 5 is bottom up plan view of the left vehicle mirror; FIG. 6 is a rear view of the left vehicle mirror; and, FIG. 7 is a right side elevational view of the left vehicle mirror.

The vehicle mirror is designed to blend with surfaces of adjacent vehicle panels. To the extent that any feature lines are illustrated, they are intended to illustrate the crest and valley of the feature and are not necessarily sharp bends in the part. Shading is used to illustrate the curvature of the part and not color.

Illustrated in FIGS. 1-7 is a left vehicle mirror. The right vehicle mirror is similar to the left vehicle mirror and is not illustrated. The right vehicle mirror is an alternative embodiment and covered by the views illustrated in FIGS. 1-7.

The broken line showing of environment is for illustrative purposes only and forms no part of the claimed design.

1 Claim, 7 Drawing Sheets

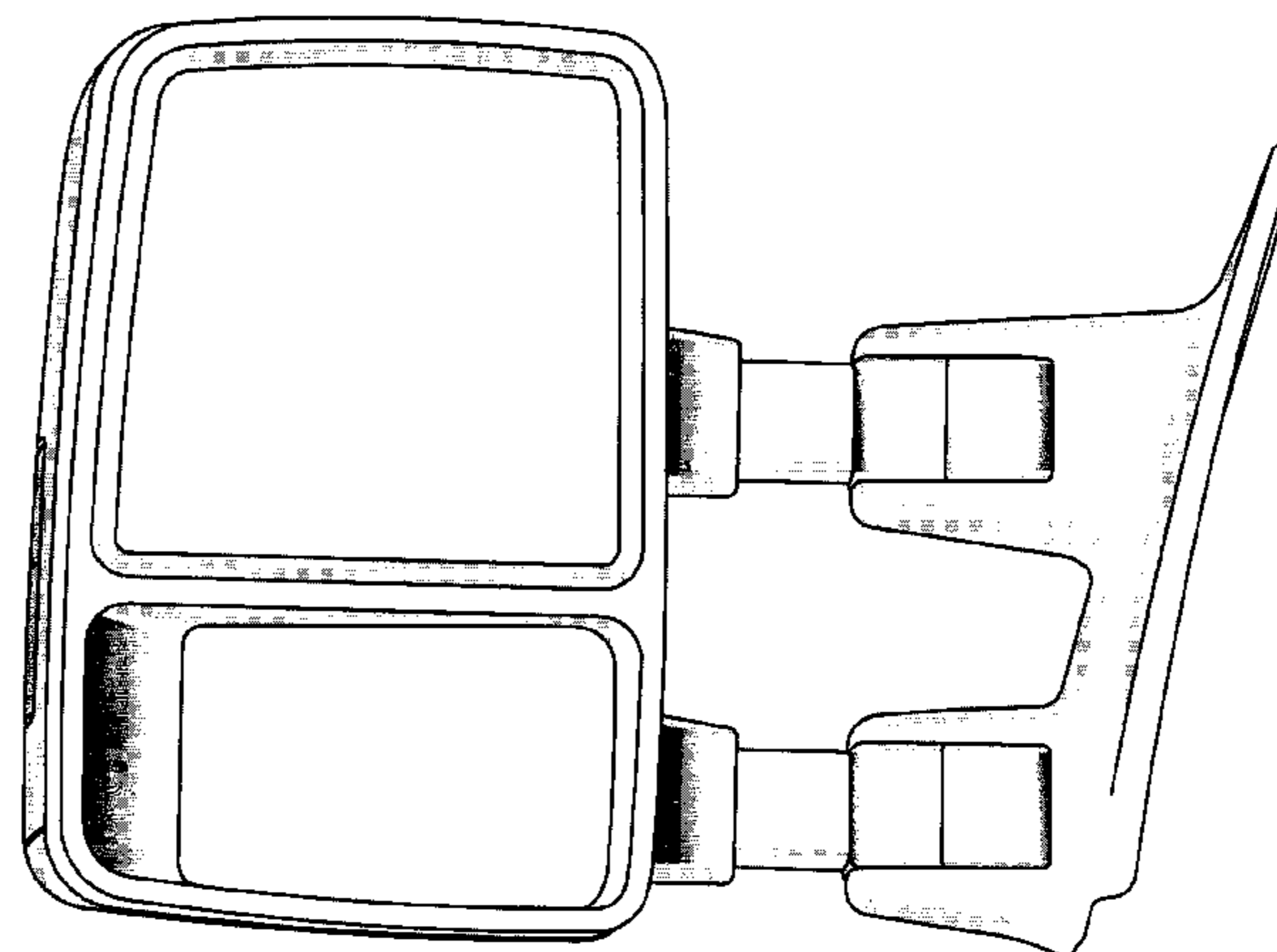
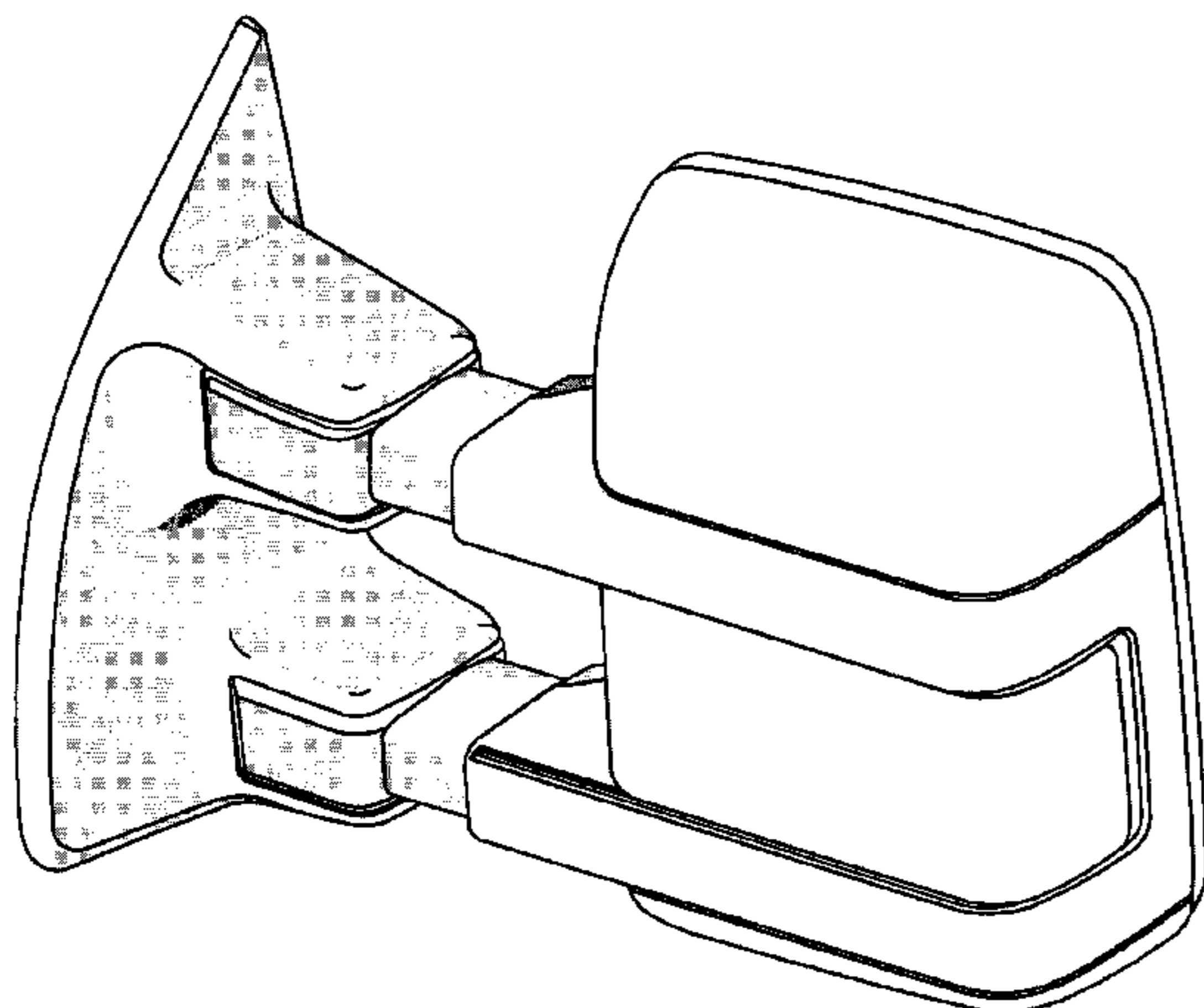

OTHER PUBLICATIONS

- Detroit News Online, *Ford tests a hydrogen F-350*, Sep. 7, 2004, <http://www.detnews.com/2004/autoinsider/0409/07/b01-265187.htm>.
- Detroit News Online, *Ford's Super Duty pickups due for major makeover*, Dec. 22, 2004, <http://info.detnews.com/autosinsider/sneakpeek/indes.cfm?id=17263>.
- FordForums.com, *US: Spy Shot: 2007 Ford F-Series Super Duty*, Dec. 24, 2004, <http://www.fordforums.com/showthread.php?t=93973>.
- Motor Trend's Truck Trend, News Front: *Spied—2007 Super Duty*, p. 16, Mar./Apr. 2005.
- CarSpyShots.net, *2007 Ford SuperDutys (f250, f350)*, Jul. 23, 2005 <http://carspyshots.net/zerthread?id=16073>.
- CarSpyShots.net, *Re: (CD-BP)*, Sep. 1, 2005, <http://www.carspyshots.net/zerthread?id=16073>.
- TheCarConnection.com, *Ford Excursion Sinks into History*, Sep. 25, 2005, http://www.thecarconnection.com/Auto_News/Daily_Edition/Daily_Edition_Sept_30%20Oct_3_2005.S173.A9375.html.
- The Detroit News (detnews.com), *Autos Insider: Out of Gas; Ford's fuel-guzzling Excursion reaches end of line*, Sep. 30, 2005, <http://detnews.com/2005/autosinsider/0509/30/c01-332800.htm?r=truckblog.com>.
- Edmunds.com, *2007 Ford F250/F350 Large Truck*, date unknown, <http://www.edmunds.com/future/2007/ford/f250f350/100491426/preview.html>.
- Edmunds.com, *Inside Line: 2005 Excursion*, date unknown, <http://www.edmunds.com/insideline/do/ViewModelDetail/make=Ford/model=Excursion>.
- Ford Vehicles, *2005 Ford Excursion*, date unknown, <http://www.fordvehicles.com/suvs/exuursion/>.

* cited by examiner

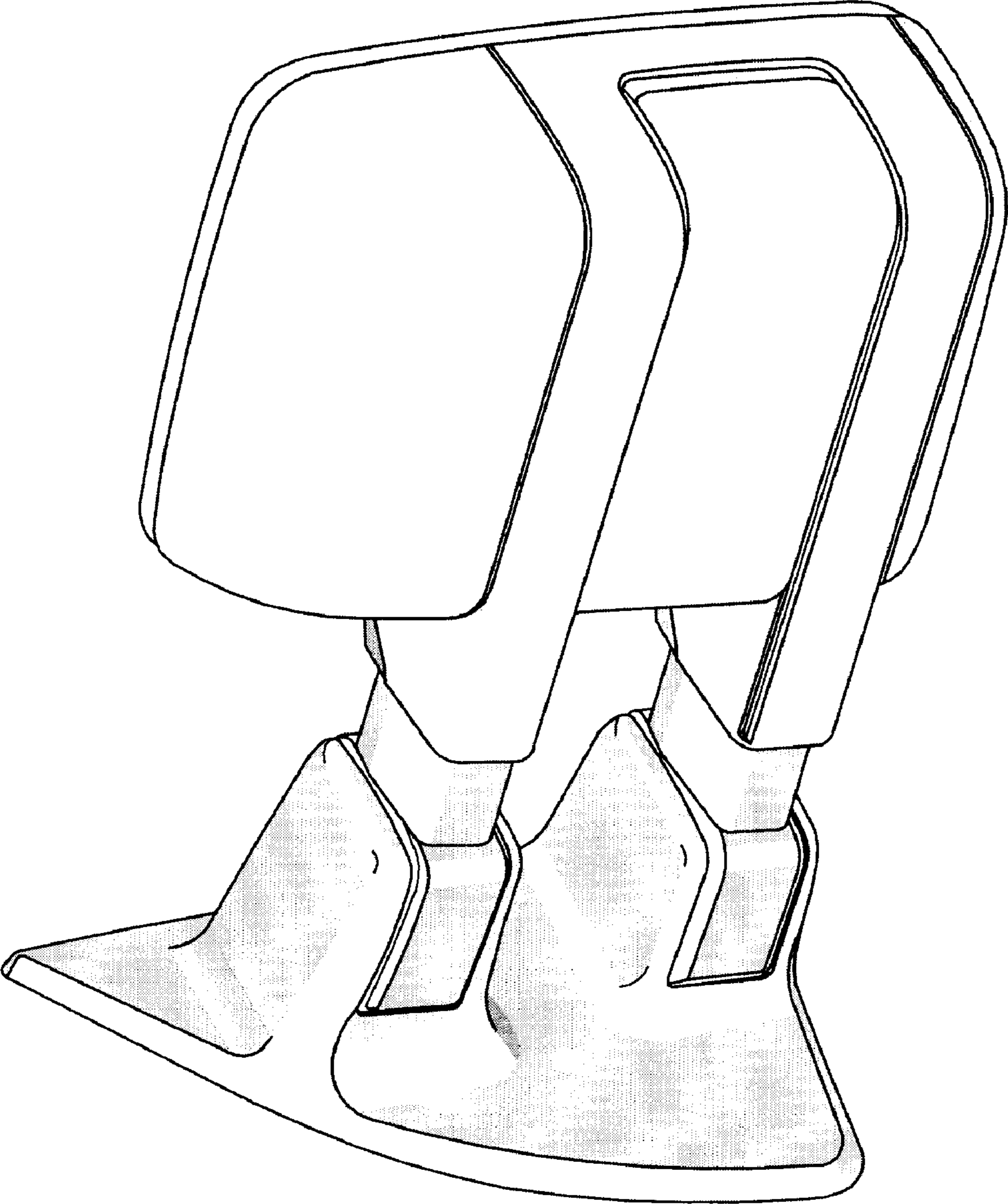

Figure 1

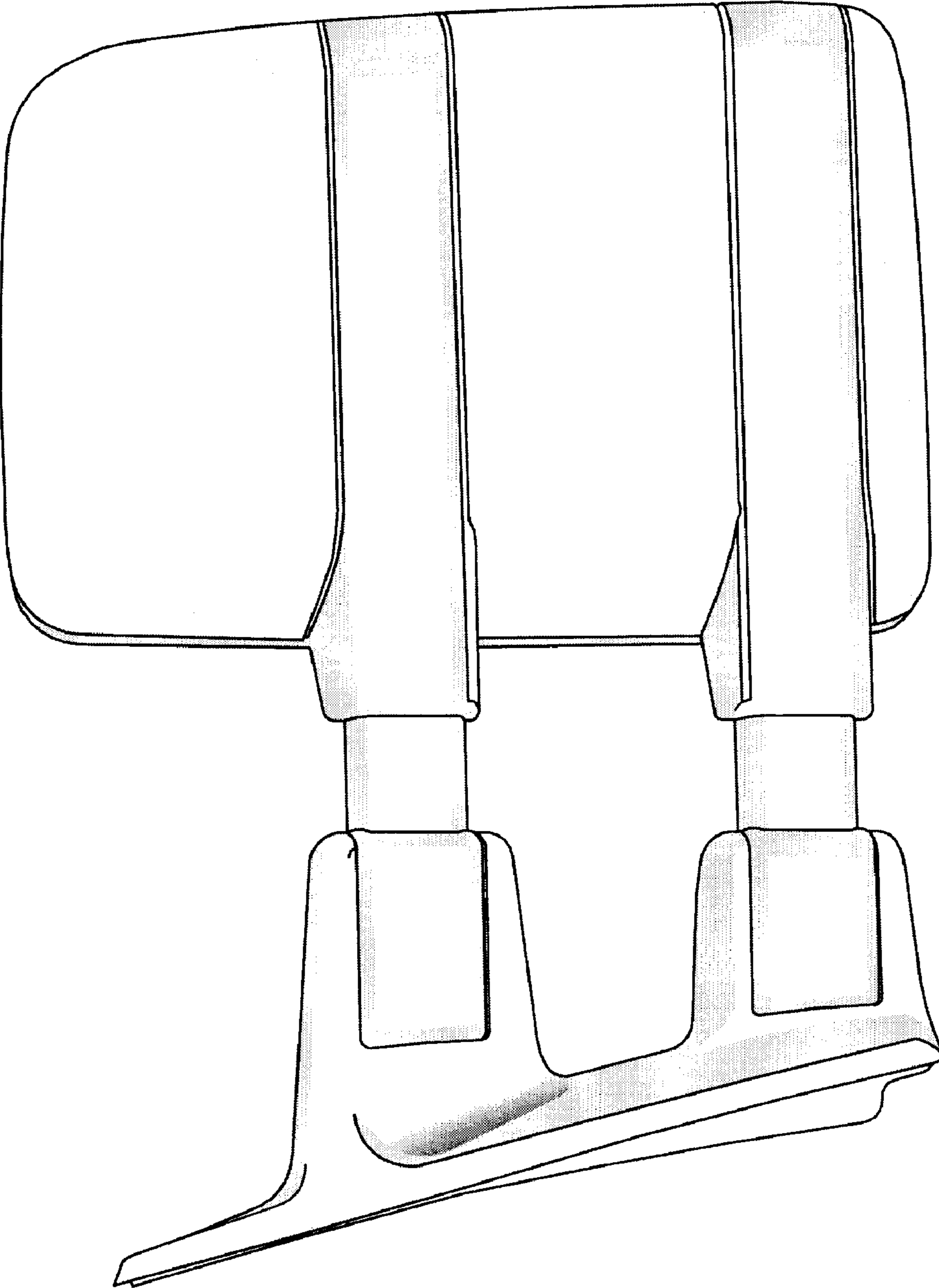

Figure 2

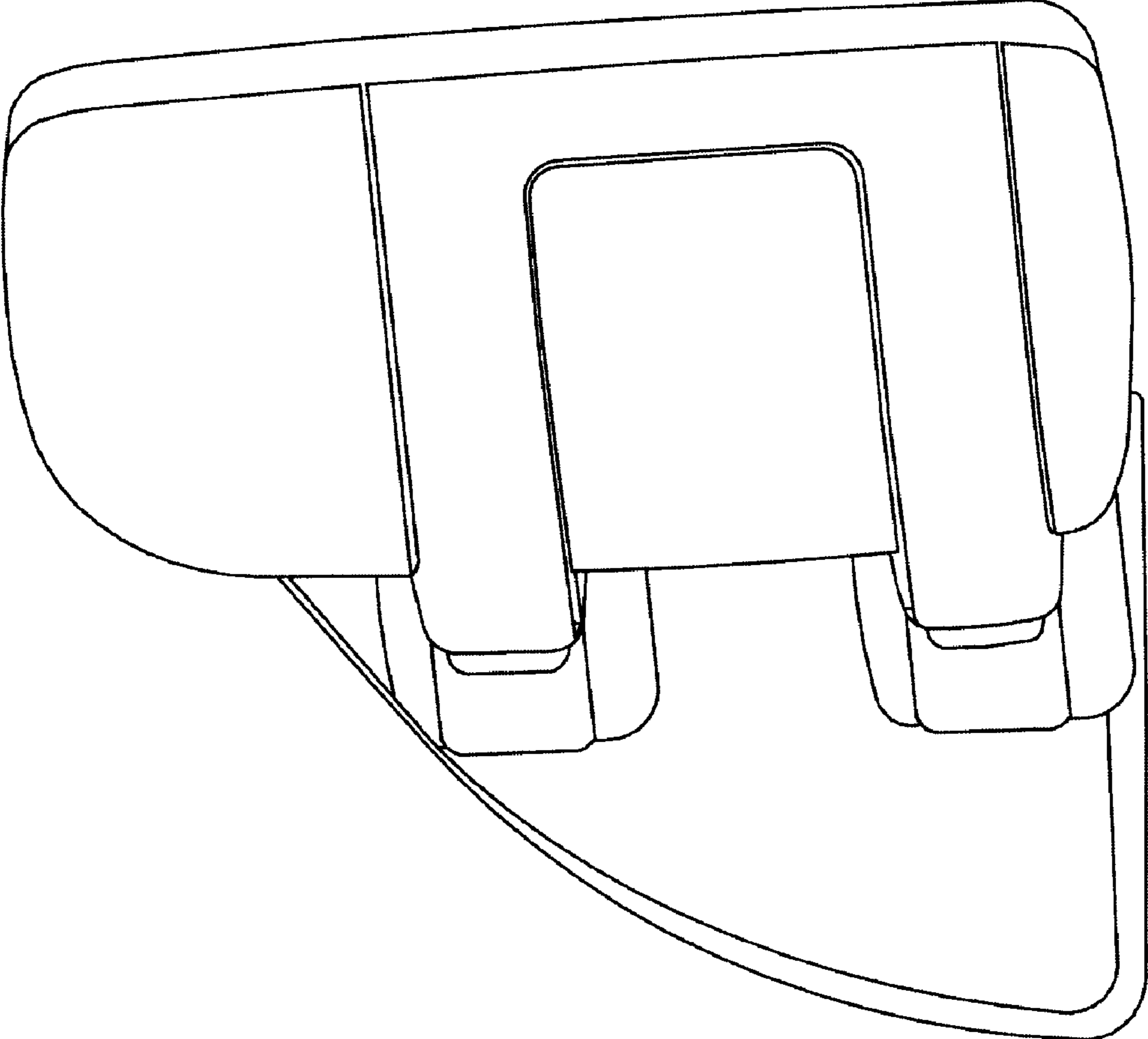

Figure 3

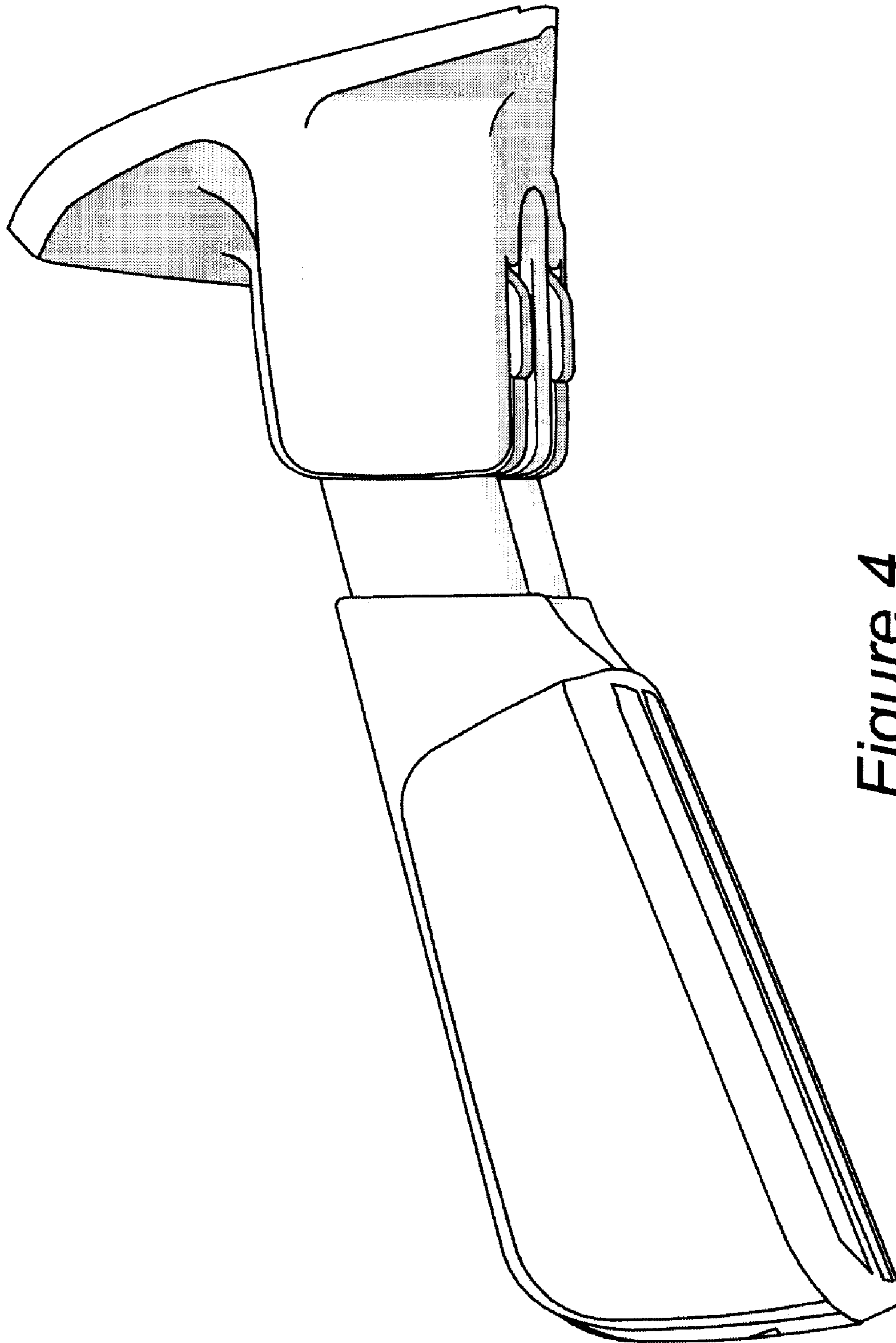

Figure 4

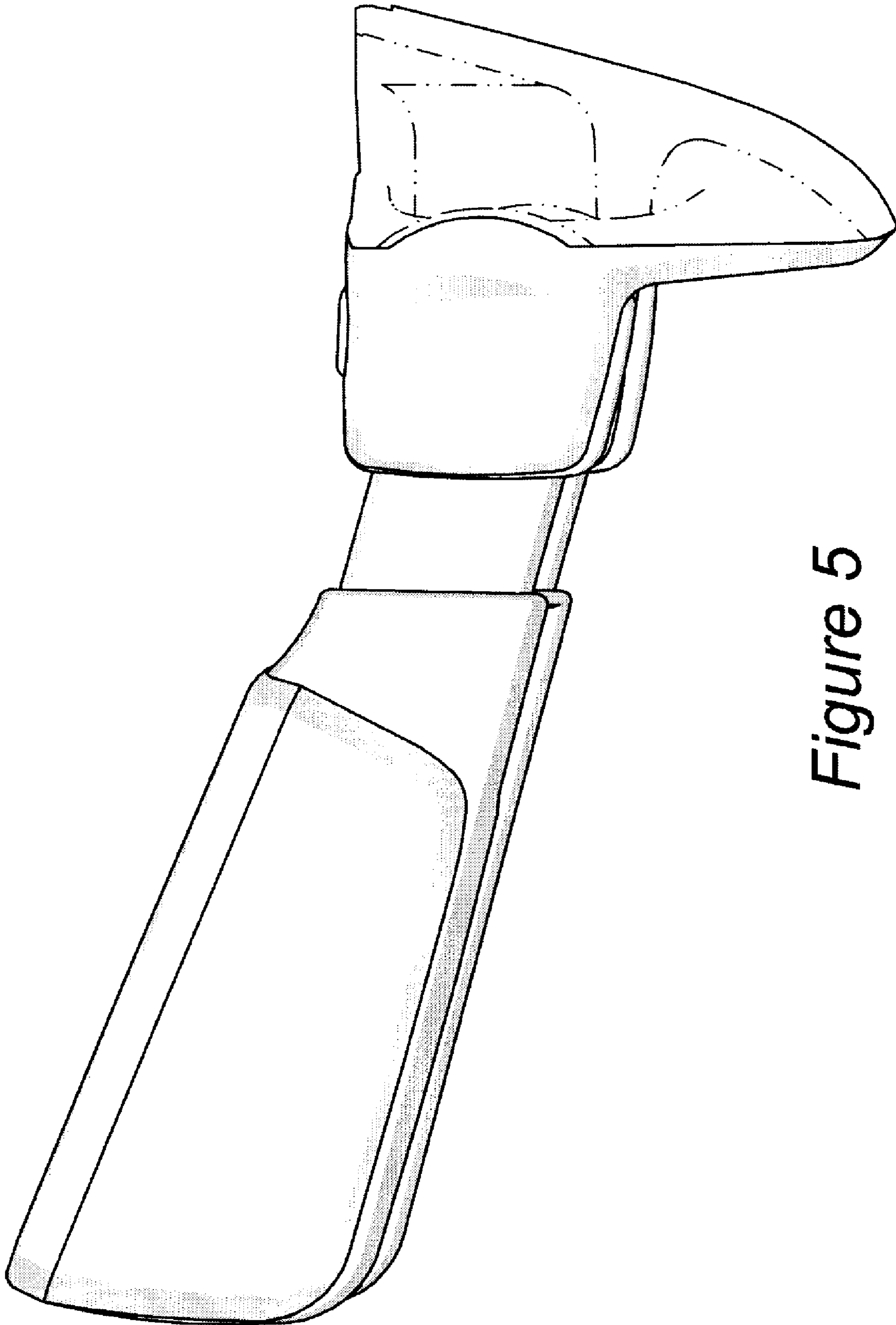

Figure 5

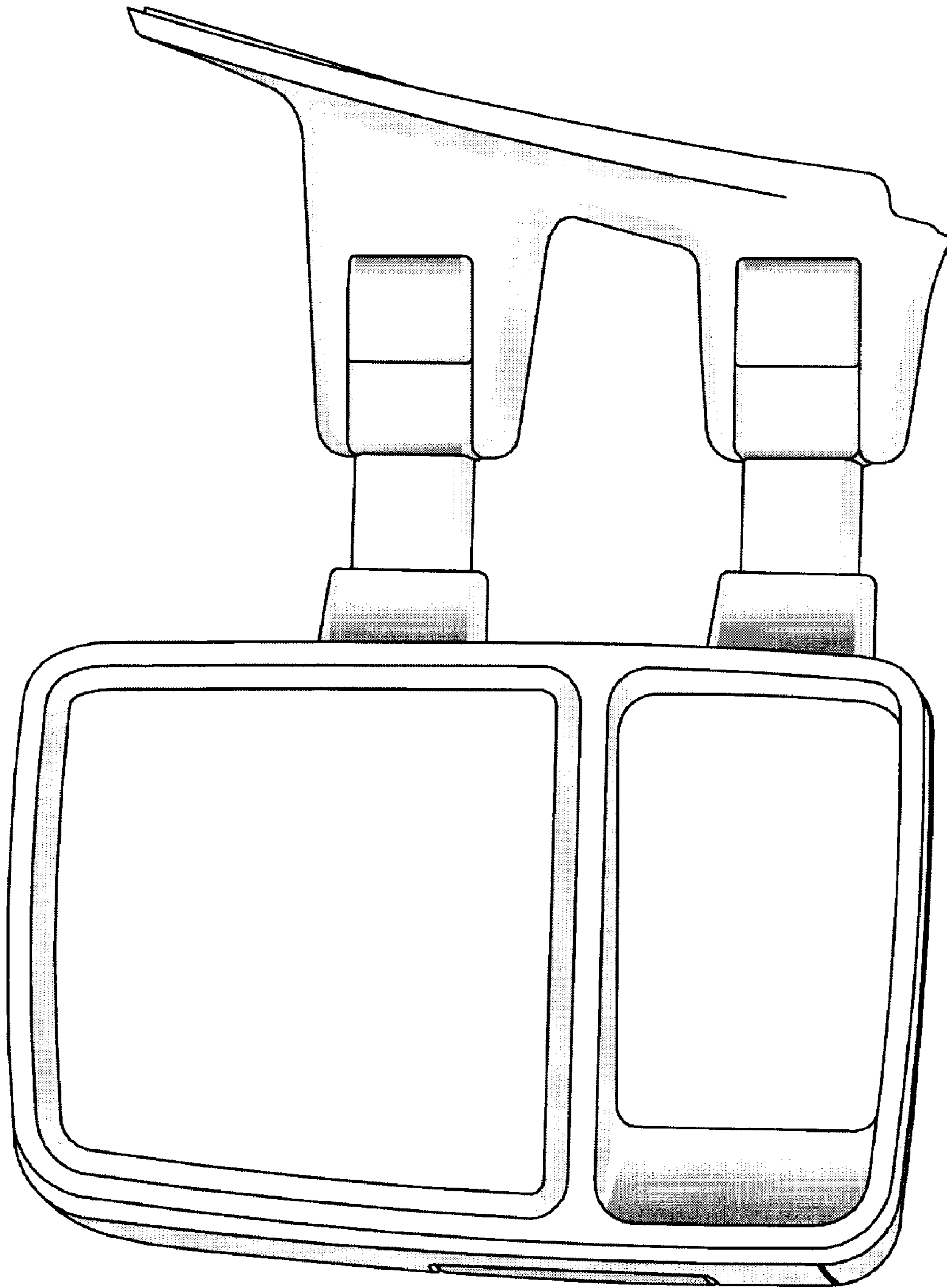

Figure 6

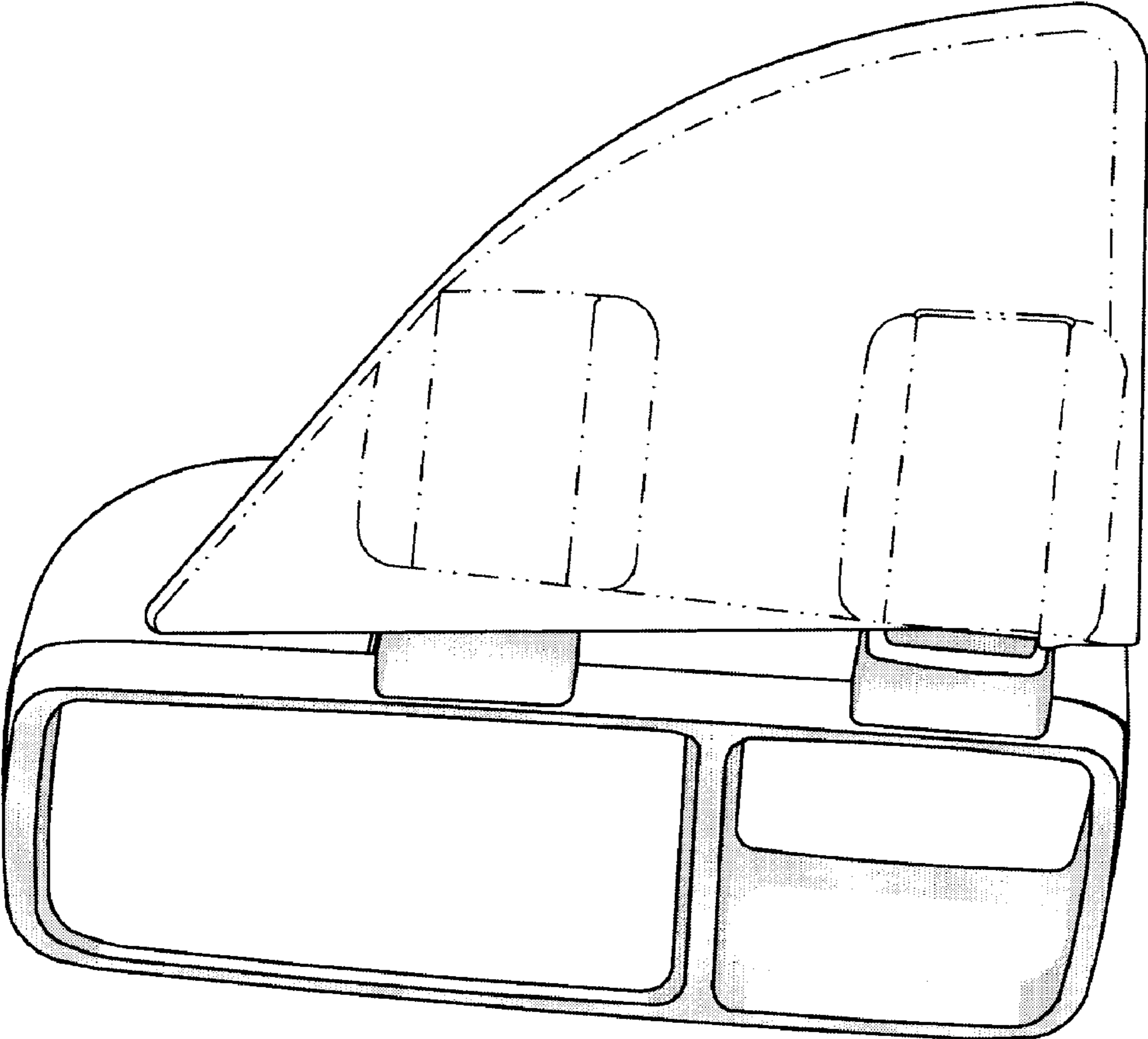

Figure 7