



US00D545729S

(12) **United States Design Patent**
Lee et al.

(10) **Patent No.:** **US D545,729 S**
(45) **Date of Patent:** **** Jul. 3, 2007**

(54) **AIR INTAKE INSERT OF A TRUCK VEHICLE**

(75) Inventors: **Kwan W. Lee**, Troy, MI (US); **Kris K. Timmerman**, Huntertown, IN (US); **Craig L. Randolph**, Fort Wayne, IN (US); **James M. Oleson**, Crestview, FL (US)

(73) Assignee: **International Truck and Engine Corporation Canada**, Warrenville, IL (US)

(**) Term: **14 Years**

(21) Appl. No.: **29/255,449**

(22) Filed: **Mar. 7, 2006**

(51) **LOC (8) Cl.** **12-16**

(52) **U.S. Cl.** **D12/163**

(58) **Field of Classification Search** D12/163,
D12/93, 96, 97, 169, 196; 180/68.1, 68.3,
180/68.6, 69.2, 69.21; 123/198.5; 55/385.3
See application file for complete search history.

(56) **References Cited**

U.S. PATENT DOCUMENTS

D367,027 S * 2/1996 Onopa D12/173
D429,195 S * 8/2000 Gabath D12/163

D489,649 S * 5/2004 Satou et al. D12/96
D497,860 S * 11/2004 Hoelzel et al. D12/196
D502,898 S * 3/2005 Delashaw et al. D12/163
D504,844 S * 5/2005 Sasanami D12/110
D512,947 S * 12/2005 Buerlein D12/196
D514,480 S * 2/2006 Yamaji et al. D12/163
D526,942 S * 8/2006 Delashaw et al. D12/163

* cited by examiner

Primary Examiner—Melody N. Brown

(74) *Attorney, Agent, or Firm*—Gerald W. Askew; Jeffrey P. Calfa; Susan L. Lukasik

(57) **CLAIM**

The ornamental design for an air intake insert of a truck vehicle, as shown and described.

DESCRIPTION

FIG. 1 is a right, front perspective view of an air intake insert of a truck vehicle showing our new design;

FIG. 2 is a front view thereof;

FIG. 3 is a top view thereof;

FIG. 4 is a left view thereof;

FIG. 5 is a right view thereof; and,

FIG. 6 is a bottom view thereof.

1 Claim, 2 Drawing Sheets

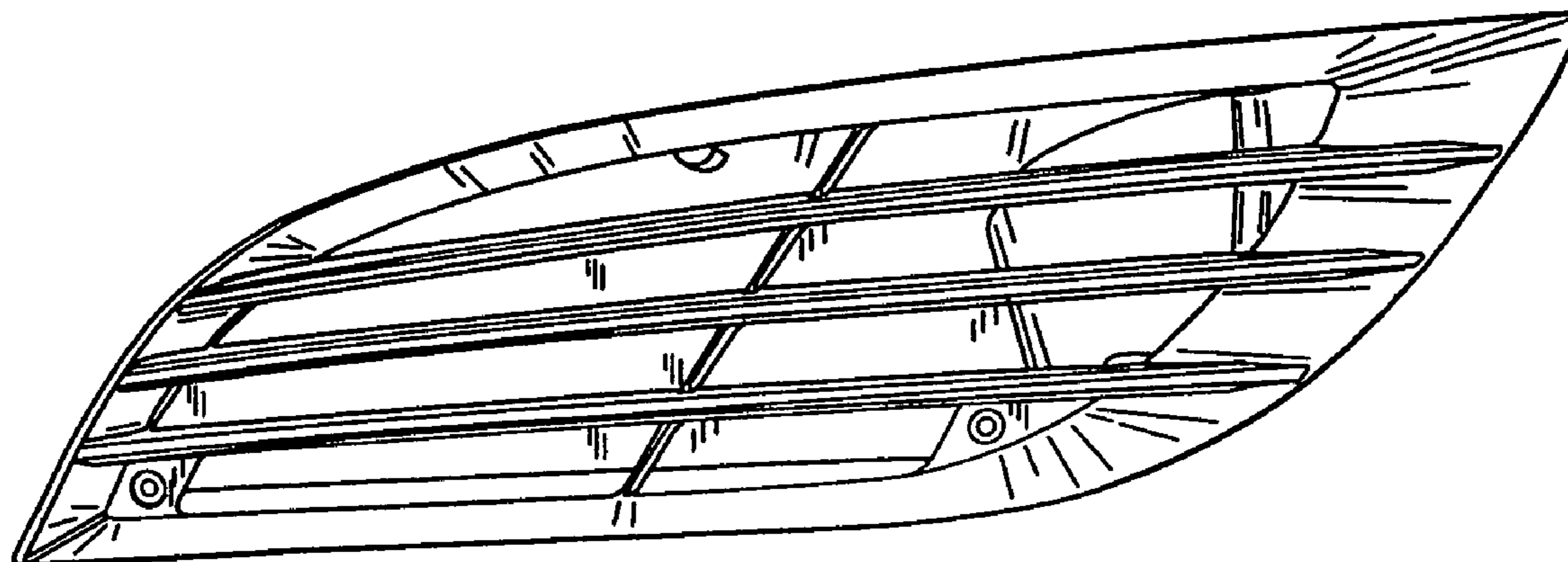

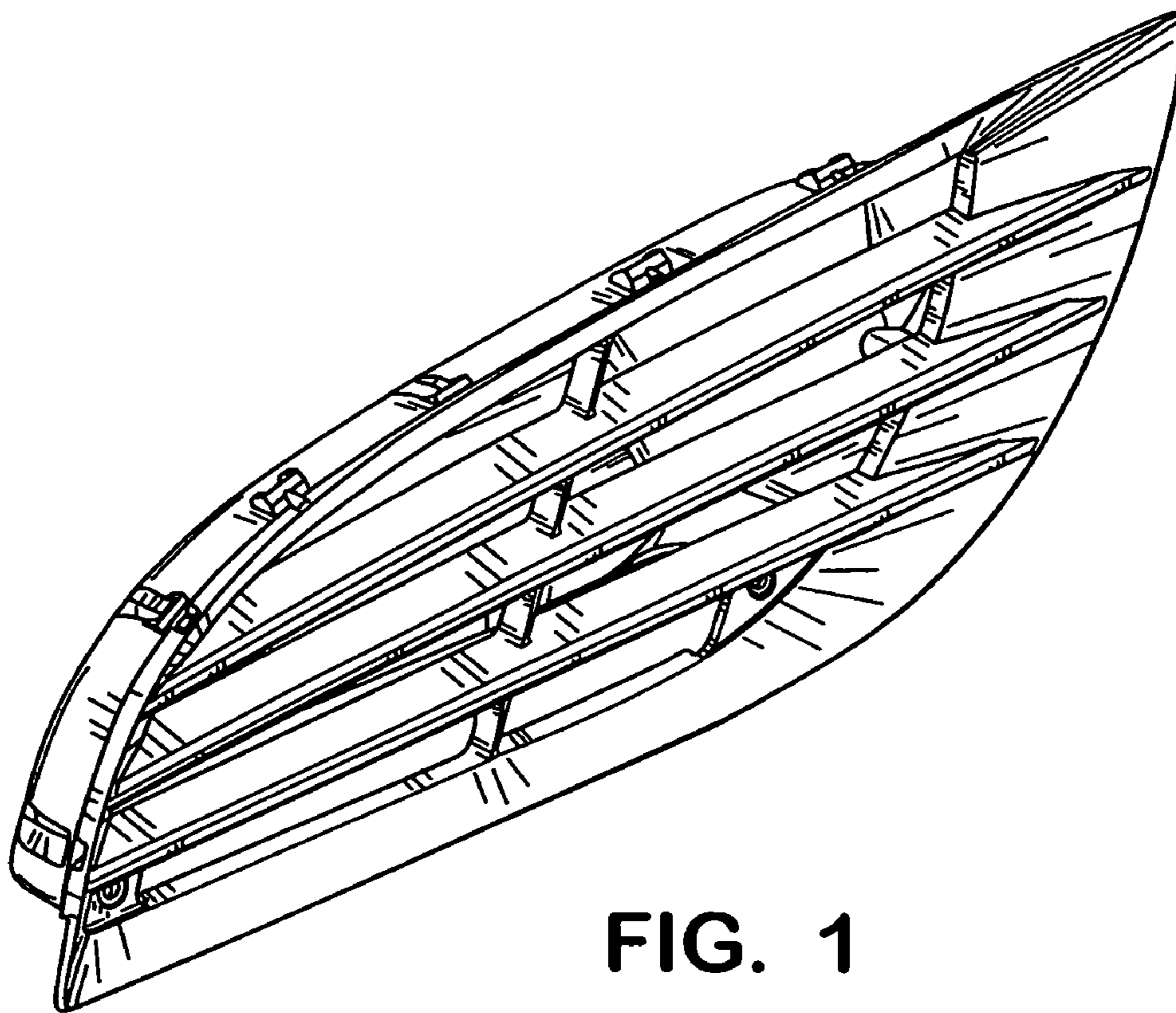

FIG. 1

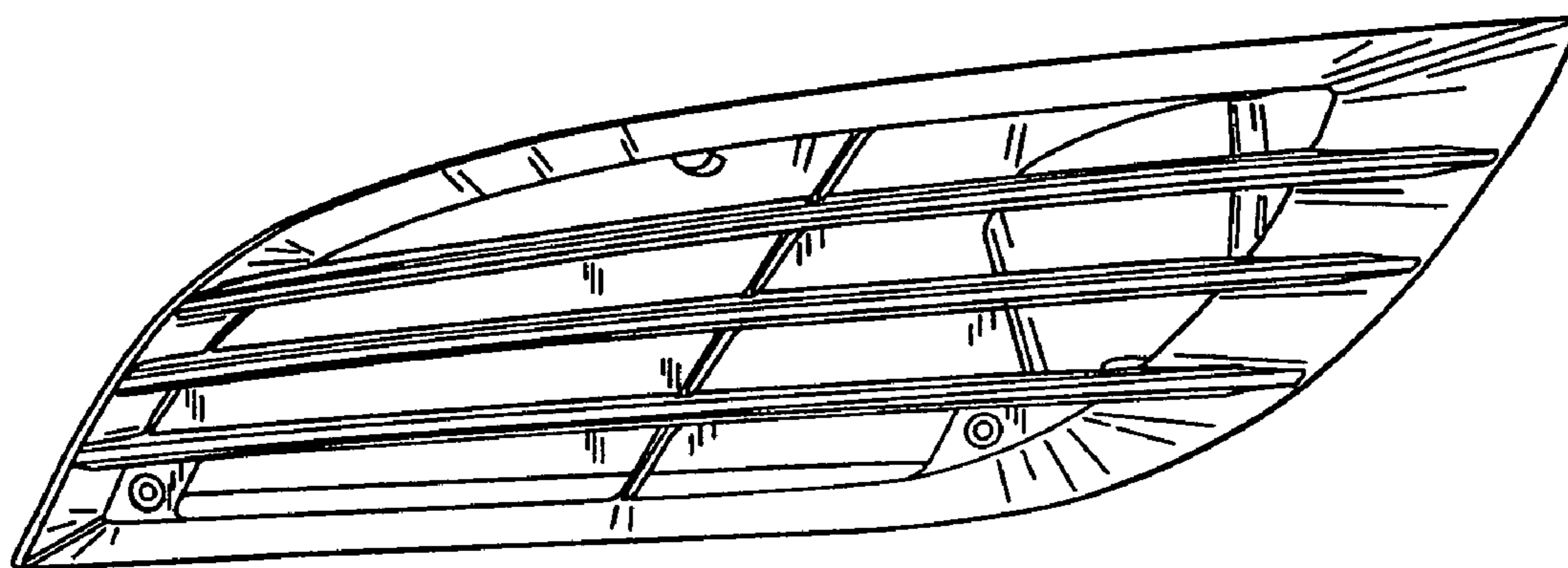

FIG. 2

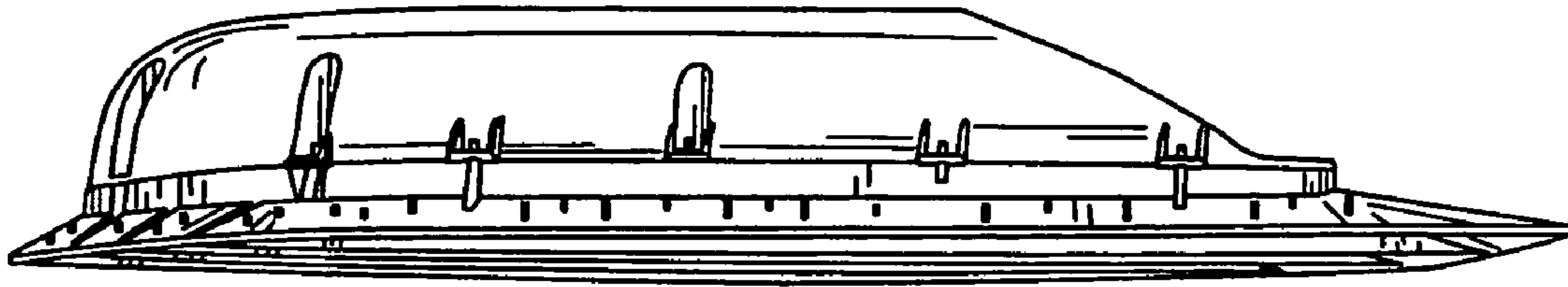

FIG. 3

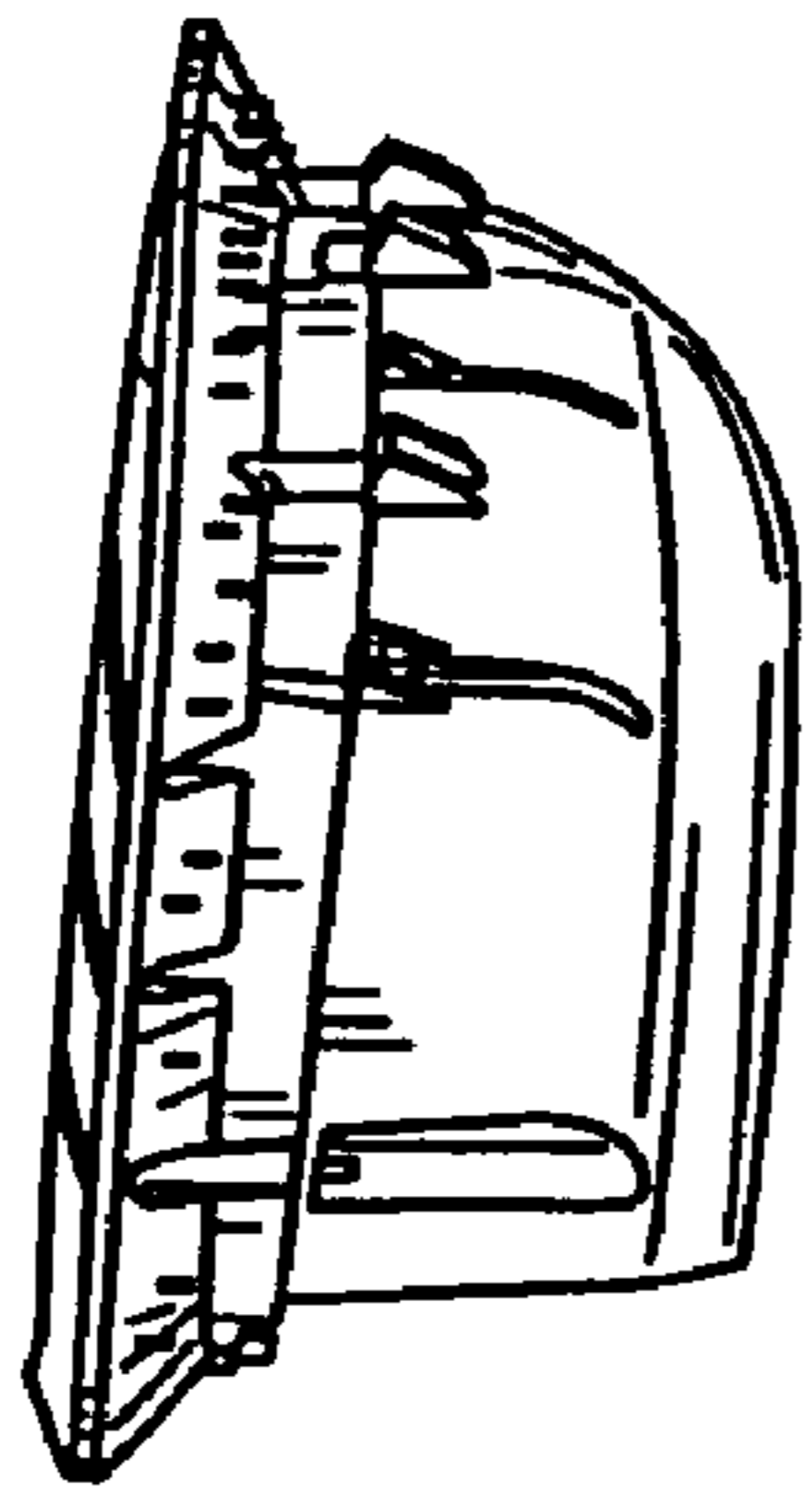

FIG. 4

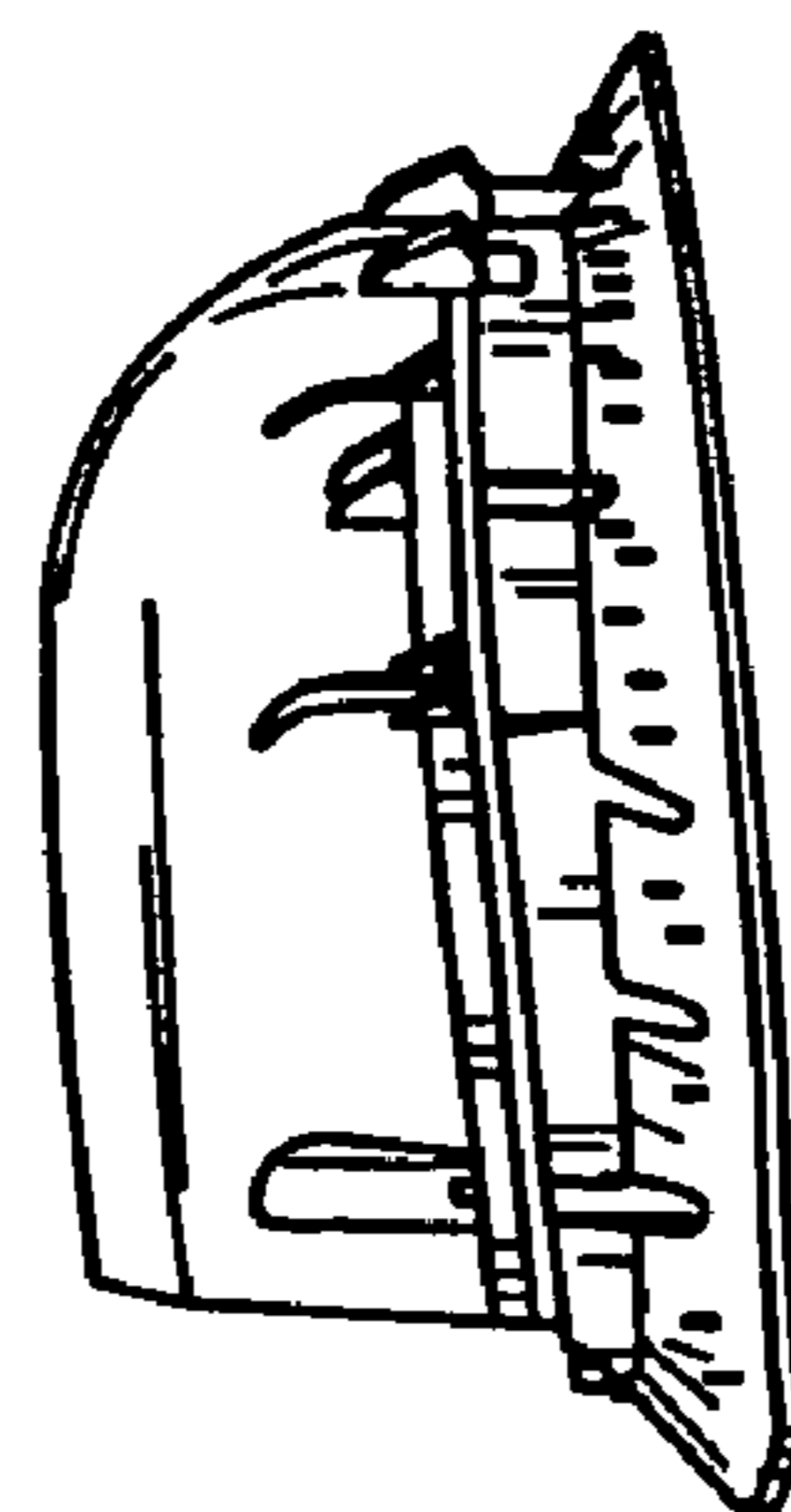

FIG. 5

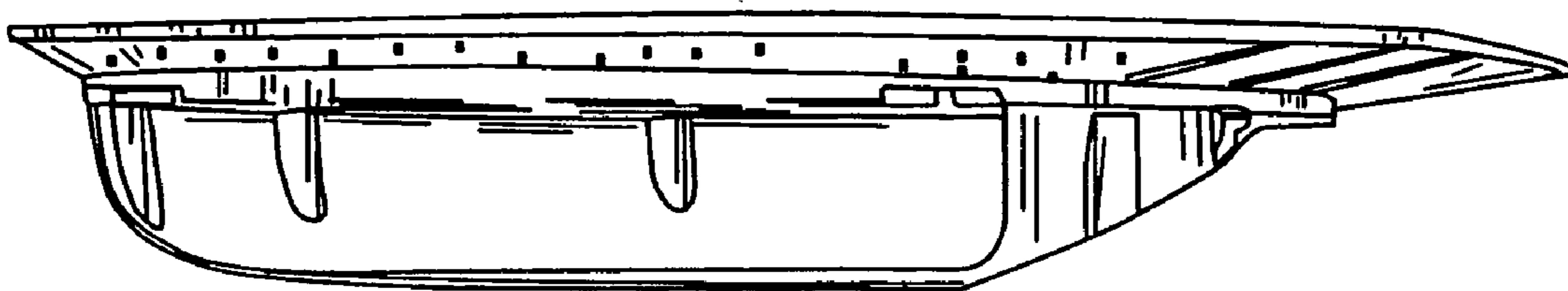

FIG. 6