

US00D545724S

(12) **United States Design Patent**
Price

(10) **Patent No.:** **US D545,724 S**

(45) **Date of Patent:** **** Jul. 3, 2007**

(54) **LOAD-CARRYING MOTOR VEHICLE**

(76) Inventor: **Michael David Price**, 30 Olive Way,
Werribee, Victoria 3030 (AU)

(**) Term: **14 Years**

(21) Appl. No.: **29/240,708**

(22) Filed: **Oct. 17, 2005**

(30) **Foreign Application Priority Data**

Apr. 18, 2005 (AU) 11560/2005

(51) **LOC (8) Cl.** **12-11**

(52) **U.S. Cl.** **D12/110; D12/109**

(58) **Field of Classification Search** D12/1,
D12/107, 110, 102, 105, 109; 180/218-231,
180/252, 291, 313, 24.12, 24.01, 375, 6.44,
180/271, 6.62, 48, 7.1, 11, 198, 224, 409,
180/901, 21; 296/16, 187.08, 187.13, 193.07,
296/37.1, 18; 414/334, 352, 462, 572, 679;
280/202, 231, 273, 282

See application file for complete search history.

(56) **References Cited**

U.S. PATENT DOCUMENTS

D200,145 S *	1/1965	Jones	D12/102
3,897,842 A *	8/1975	Rheaume et al.	180/219
3,935,916 A *	2/1976	Ferraro	180/219
2005/0194200 A1 *	9/2005	Larson	180/375

* cited by examiner

Primary Examiner—Alan P. Douglas

Assistant Examiner—Linda Brooks

(74) *Attorney, Agent, or Firm*—Harness, Dickey & Pierce,
PLC

(57) **CLAIM**

The ornamental design for a load-carrying motor vehicle, as shown and described.

DESCRIPTION

FIG. 1 is a front perspective view of the load-carrying motor vehicle. The casket showing in FIG. 1 is for illustrative purposes only and forms no part of the subject invention;

FIG. 2 is a rear perspective view of the load-carrying motor vehicle. The casket showing in FIG. 2 is for illustrative purposes only and forms no part of the subject invention;

FIG. 3 is a front view of the load-carrying motor vehicle. The casket showing in FIG. 3 is for illustrative purposes only and forms no part of the subject invention;

FIG. 4 is a top view of the load-carrying motor vehicle. The casket showing in FIG. 4 is for illustrative purposes only and forms no part of the subject invention;

FIG. 5 is a left side view of the load-carrying motor vehicle. The casket showing in FIG. 5 is for illustrative purposes only and forms no part of the subject invention; and,

FIG. 6 is a right side view of the load-carrying motor vehicle. The casket showing in FIG. 6 is for illustrative purposes only and forms no part of the subject invention.

1 Claim, 4 Drawing Sheets

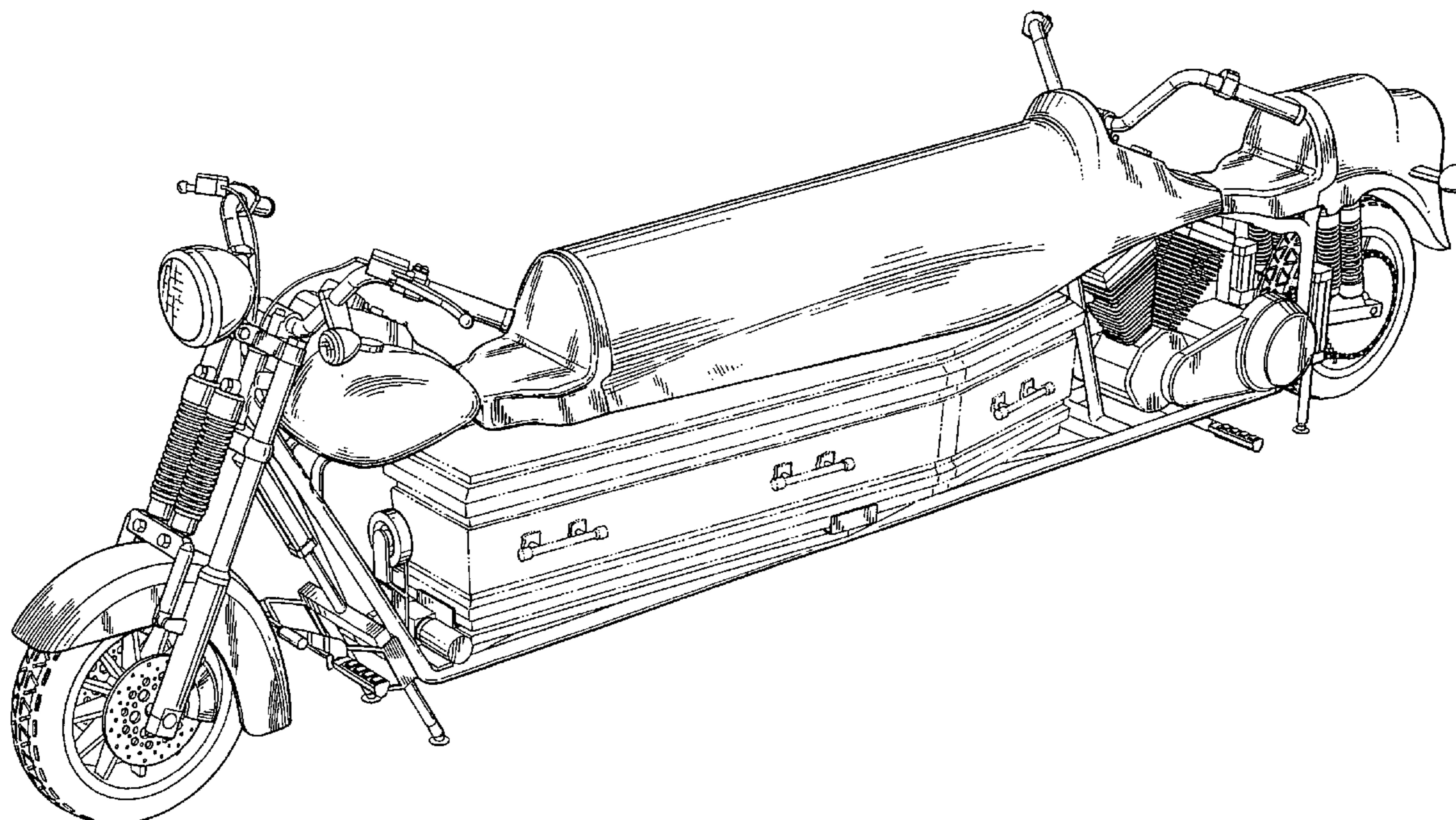

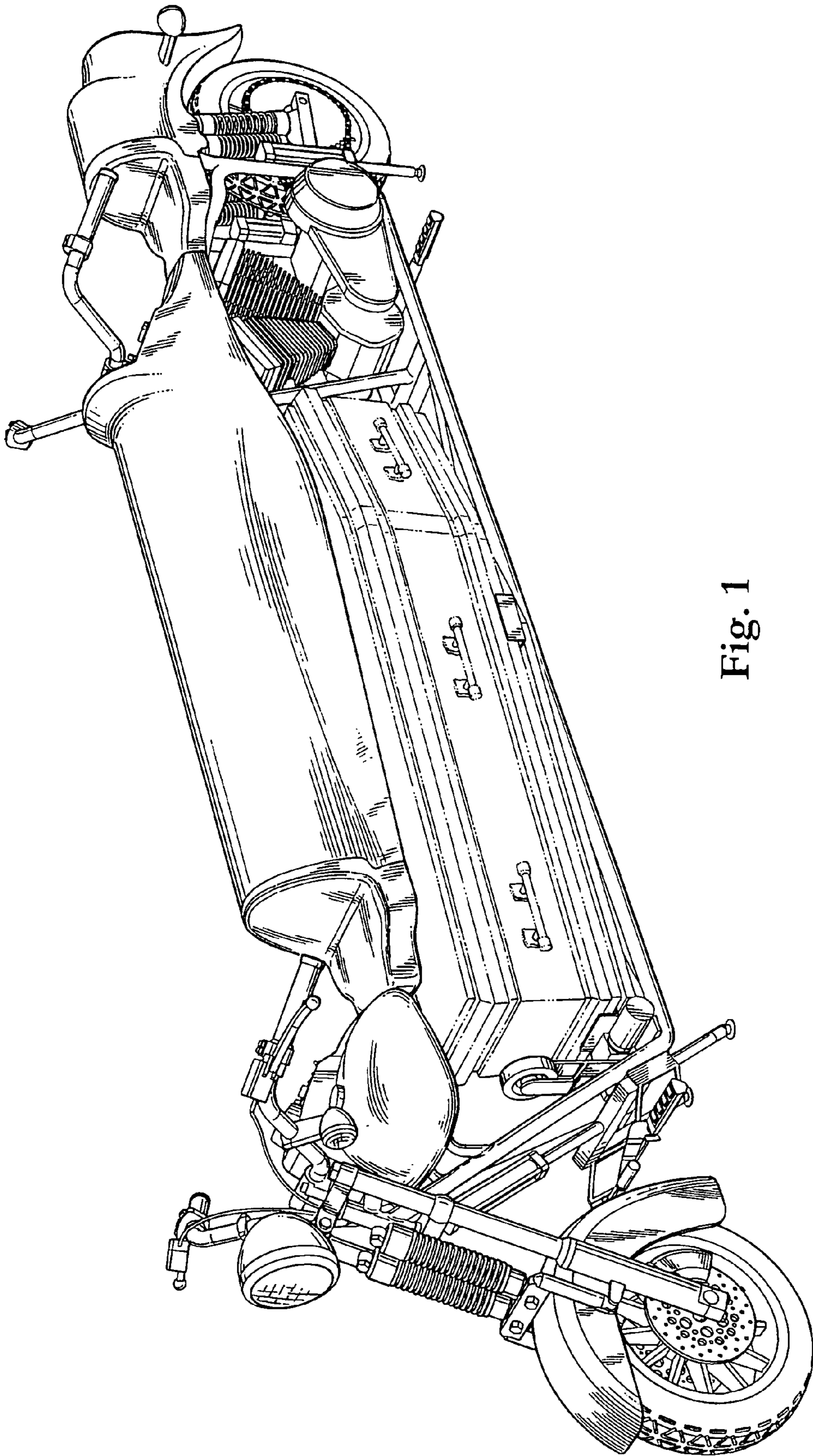

Fig. 1

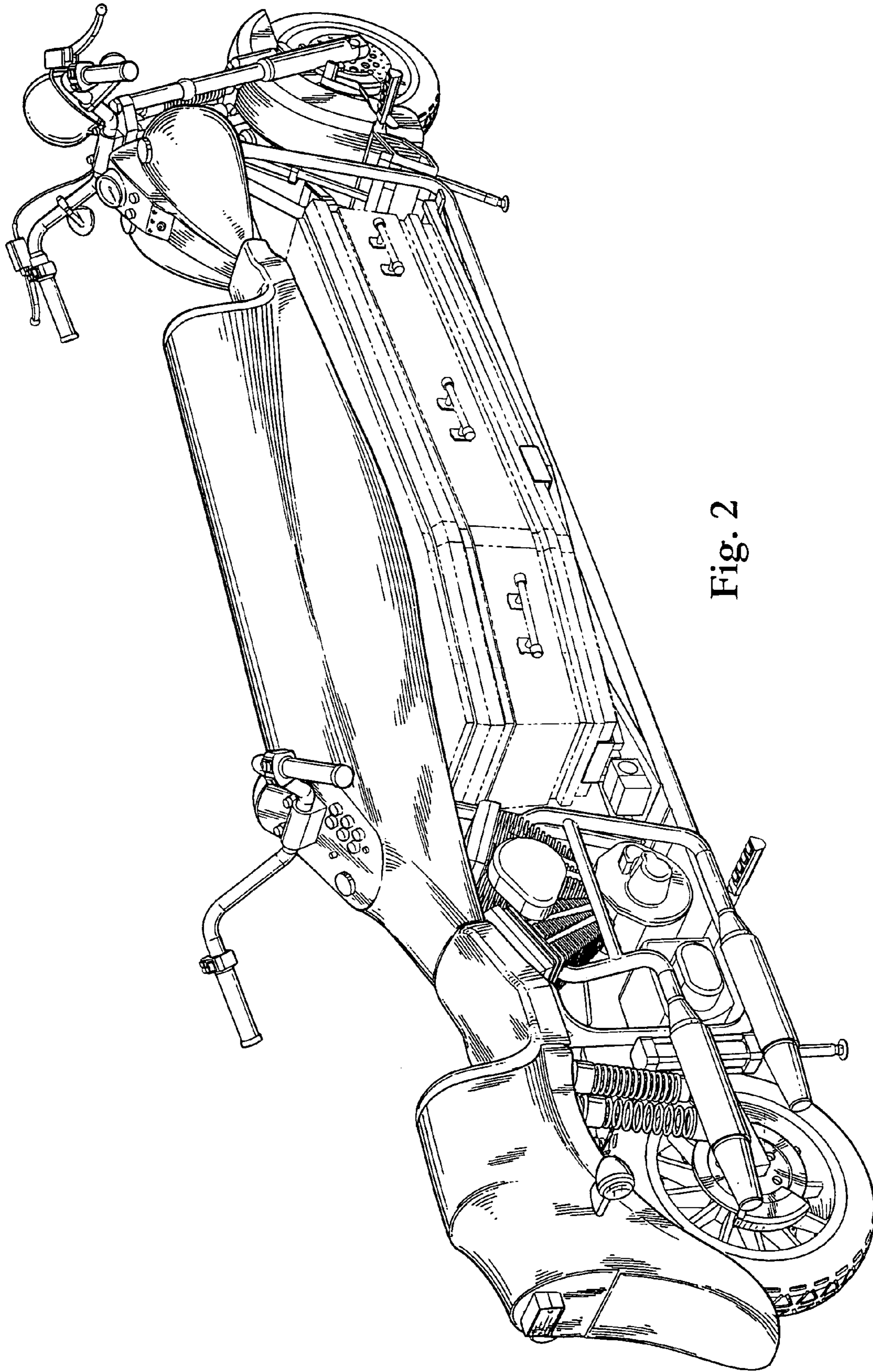

Fig. 2

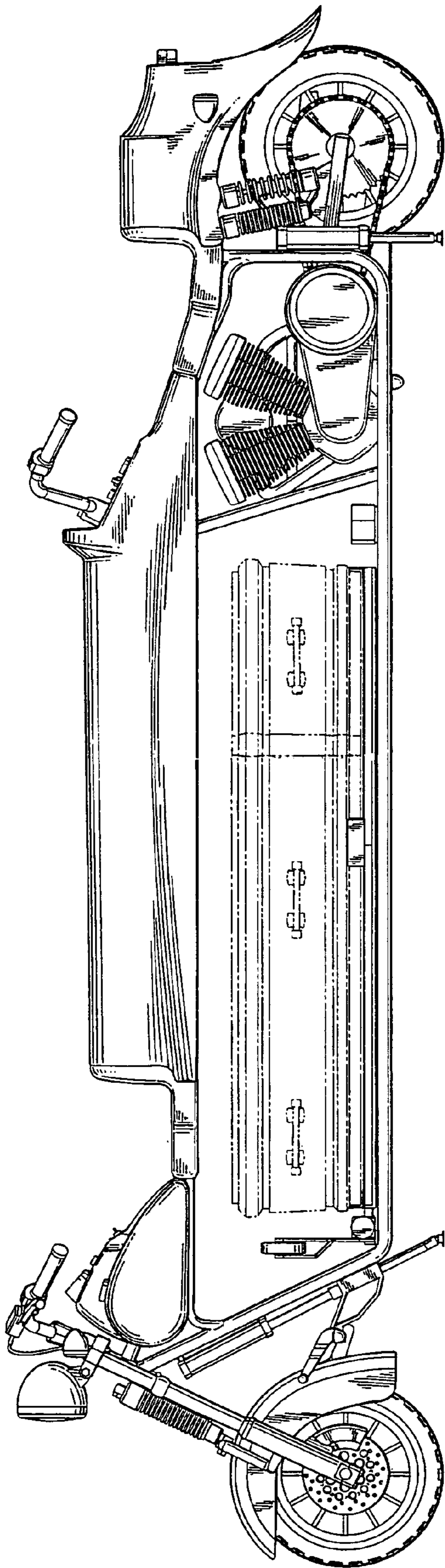

Fig. 3

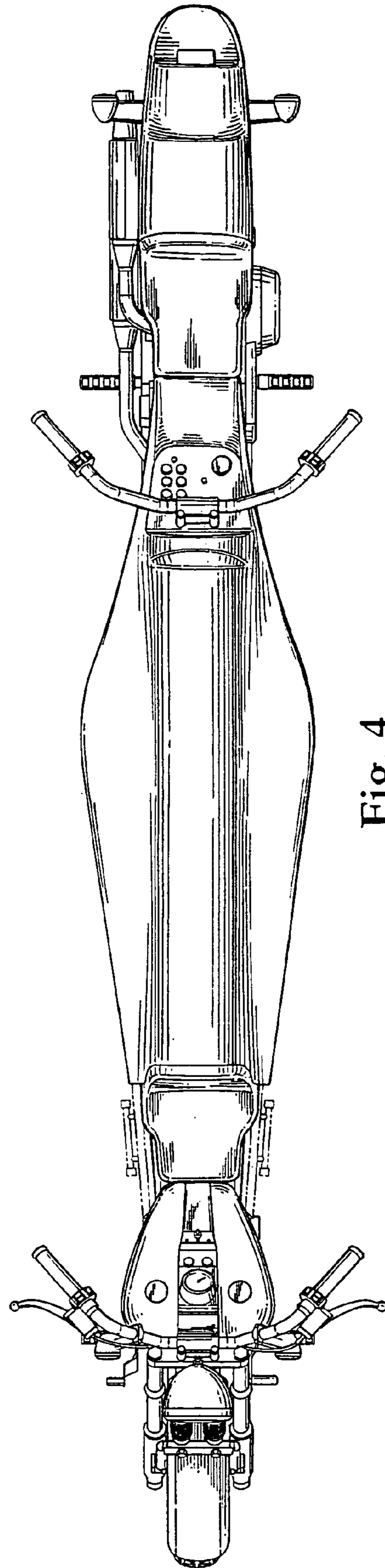

Fig. 4

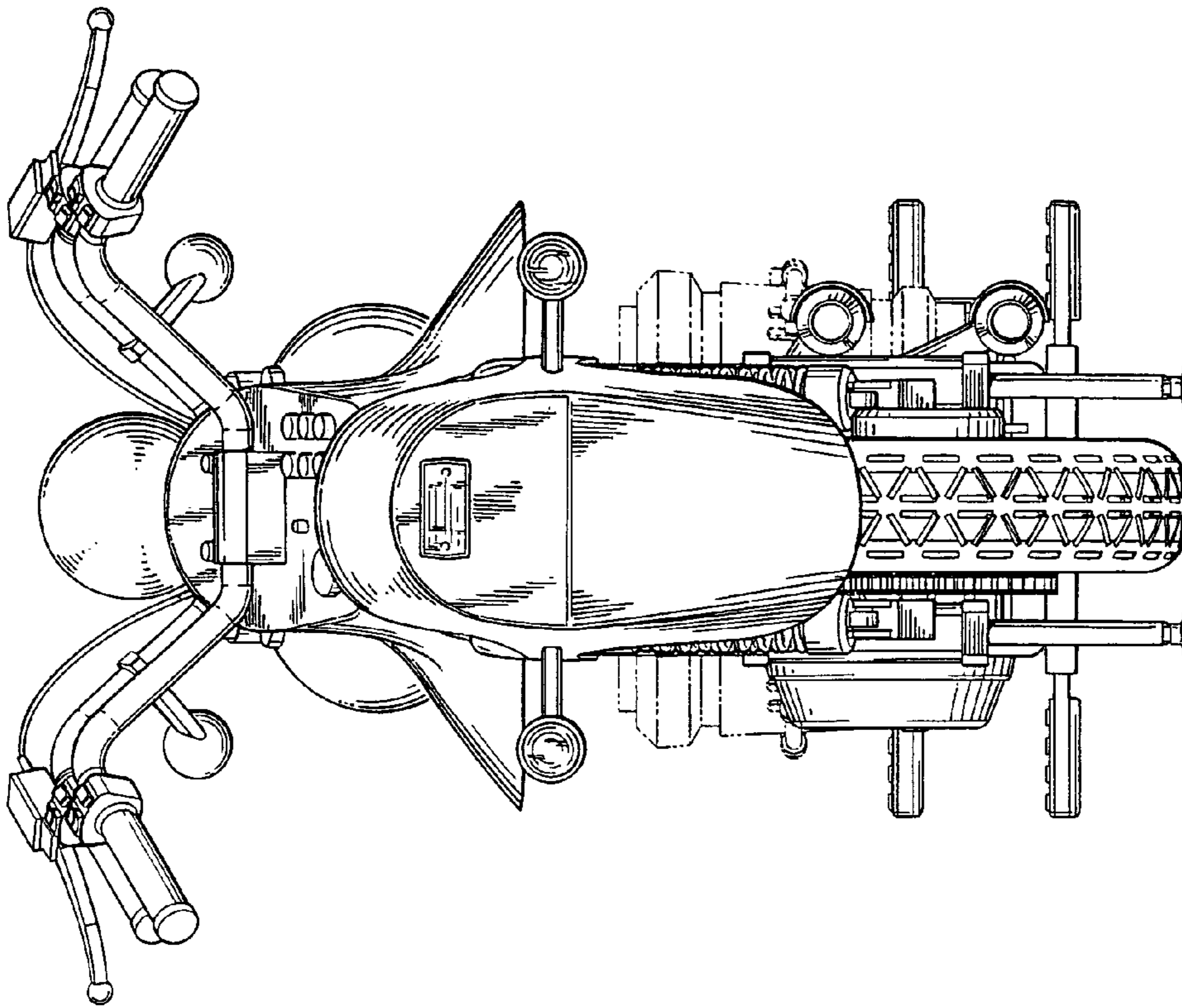

Fig. 6

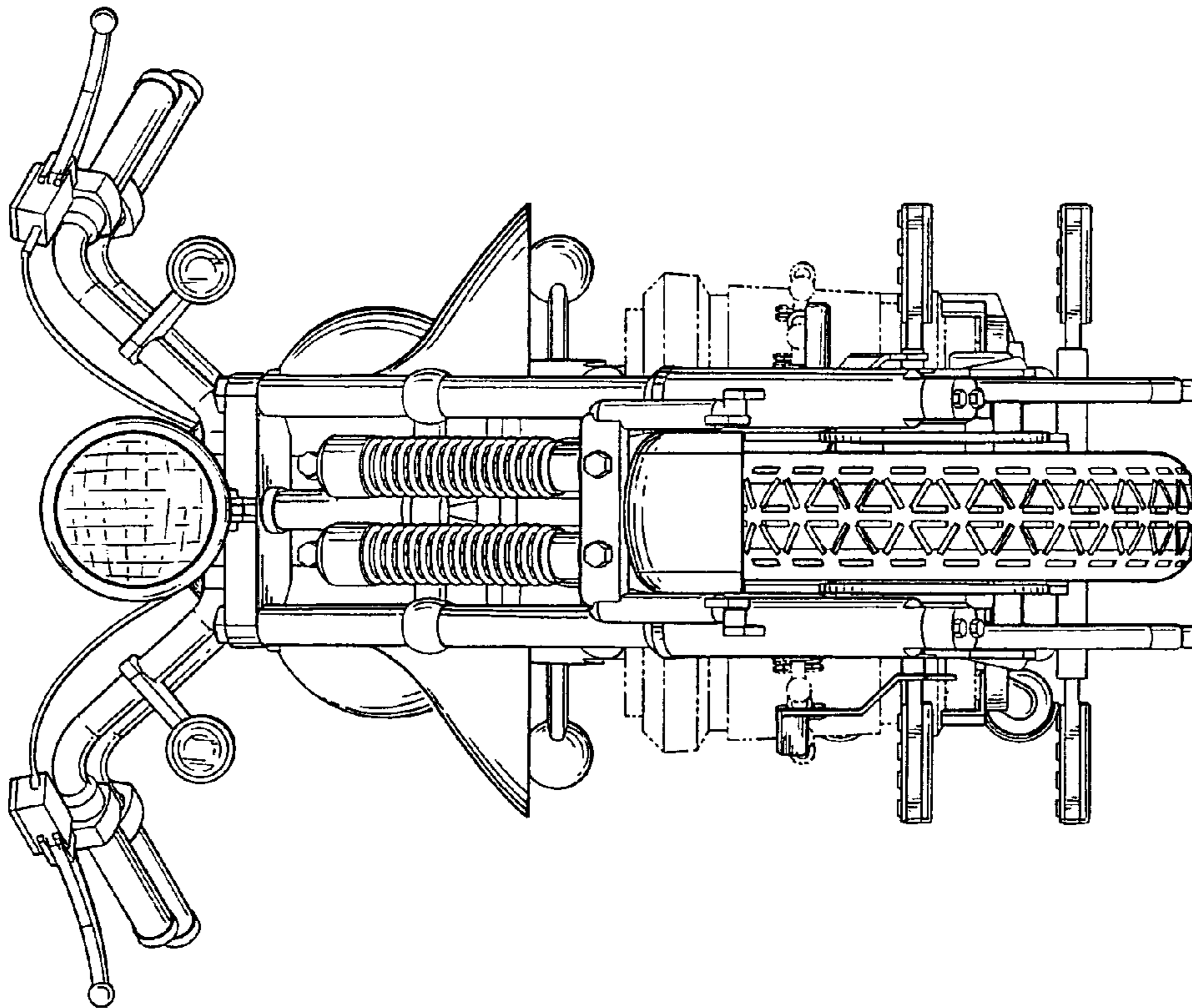

Fig. 5