

US00D545382S

(12) **United States Design Patent**
Ross, Jr.

(10) **Patent No.:** **US D545,382 S**
(45) **Date of Patent:** **** Jun. 26, 2007**

(54) **ABDOMINAL MUSCLE STANDING EXERCISER**

(76) Inventor: **Raymond Ross, Jr.**, 800 Park Ave.,
Fairfield, AL (US) 35064

(**) Term: **14 Years**

(21) Appl. No.: **29/244,403**

(22) Filed: **Dec. 8, 2005**

(51) **LOC (8) Cl.** **21-02**

(52) **U.S. Cl.** **D21/687**

(58) **Field of Classification Search** D21/662,
D21/686-687, 694; 482/15, 123, 133, 140-145,
482/800

See application file for complete search history.

(56) **References Cited**

U.S. PATENT DOCUMENTS

1,705,745	A *	3/1929	Anderson	482/123
D193,940	S *	10/1962	Campion	D21/687
D281,006	S *	10/1985	Durushia	D21/687
4,793,288	A *	12/1988	Hoadley	119/705
4,892,302	A *	1/1990	Daigle	482/15
D339,618	S *	9/1993	Hassell	D21/687
D356,352	S *	3/1995	Johnson	D21/800
5,957,817	A *	9/1999	Koenig et al.	482/72
6,022,303	A	2/2000	Abdo		
6,939,277	B2	9/2005	Tuller et al.		
7,101,328	B2 *	9/2006	Chiu	482/140
2003/0036467	A1 *	2/2003	Almada	482/140
2004/0097351	A1	5/2004	Tornabene		
2004/0180768	A1 *	9/2004	Almada	482/142

* cited by examiner

Primary Examiner—Philip S. Hyder
Assistant Examiner—RoseLynne [Ulm] Cody
(74) *Attorney, Agent, or Firm*—Kenneth M. Bush; Bush IP
Law Group, LLC

(57) **CLAIM**

The ornamental design for an abdominal muscle standing exerciser, as shown and described.

DESCRIPTION

An exercise device designed to facilitate exercising abdominal muscles from a standing position.

FIG. 1 is a front isometric view of the abdominal muscle standing exerciser;

FIG. 2 is a left side elevational view of the abdominal muscle standing exerciser;

FIG. 3 is a right side elevational view of the abdominal muscle standing exerciser;

FIG. 4 is a front elevational view of the abdominal muscle standing exerciser;

FIG. 5 is a rear elevational view of the abdominal muscle standing exerciser;

FIG. 6 is a top plan view of the abdominal muscle standing exerciser; and,

FIG. 7 is a bottom view of the abdominal muscle standing exerciser.

1 Claim, 4 Drawing Sheets

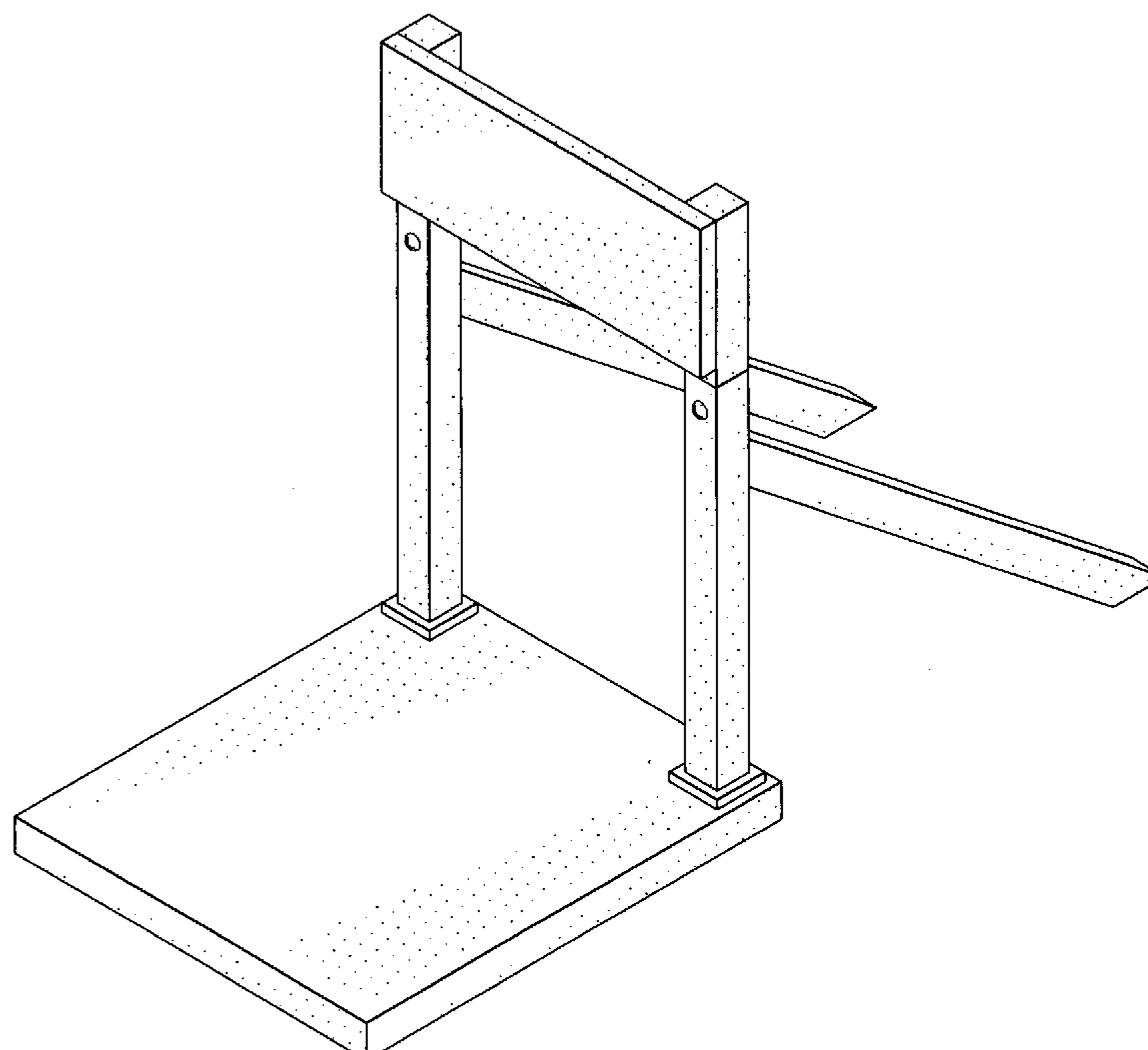

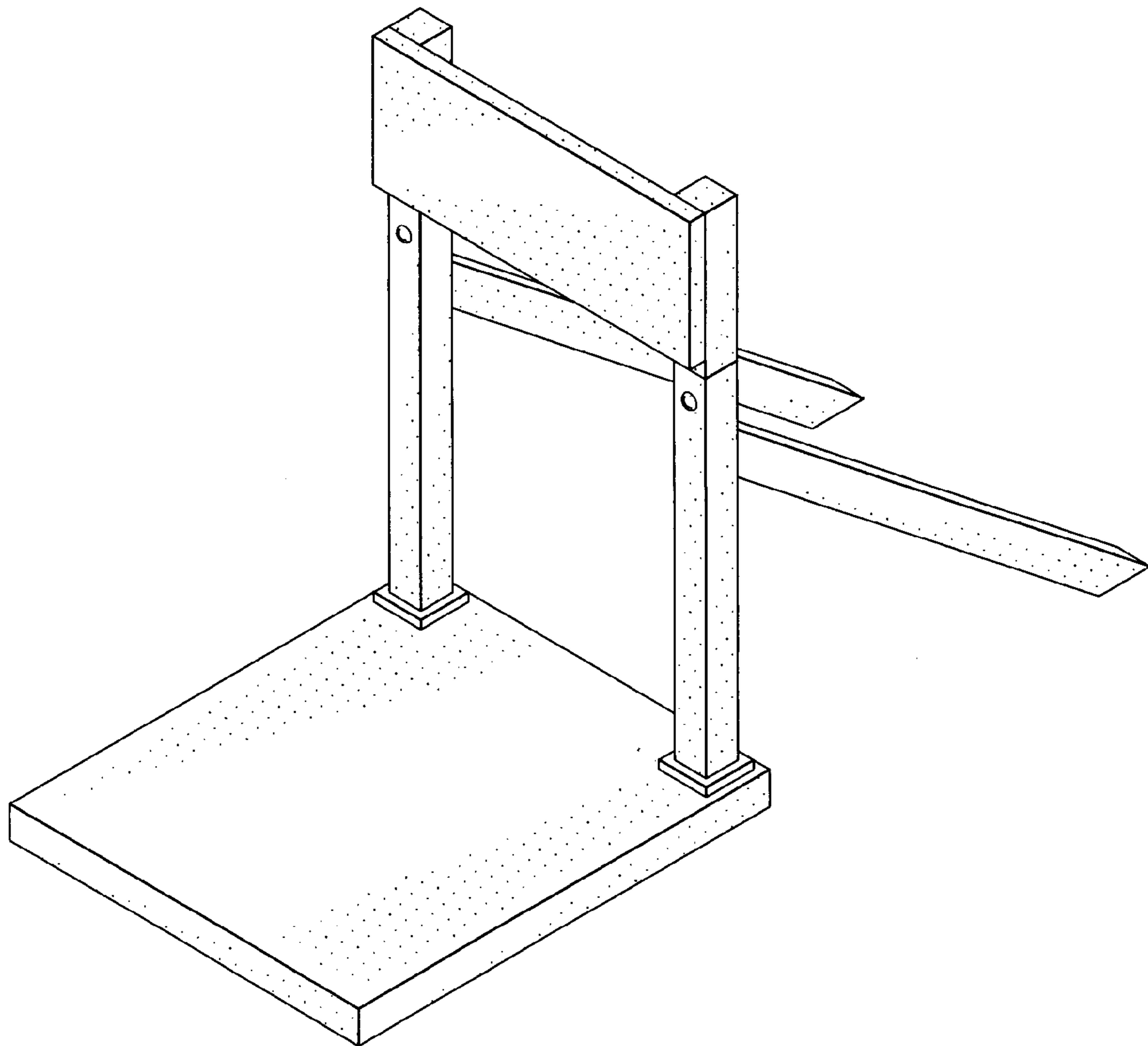

FIG. 1

FIG. 2

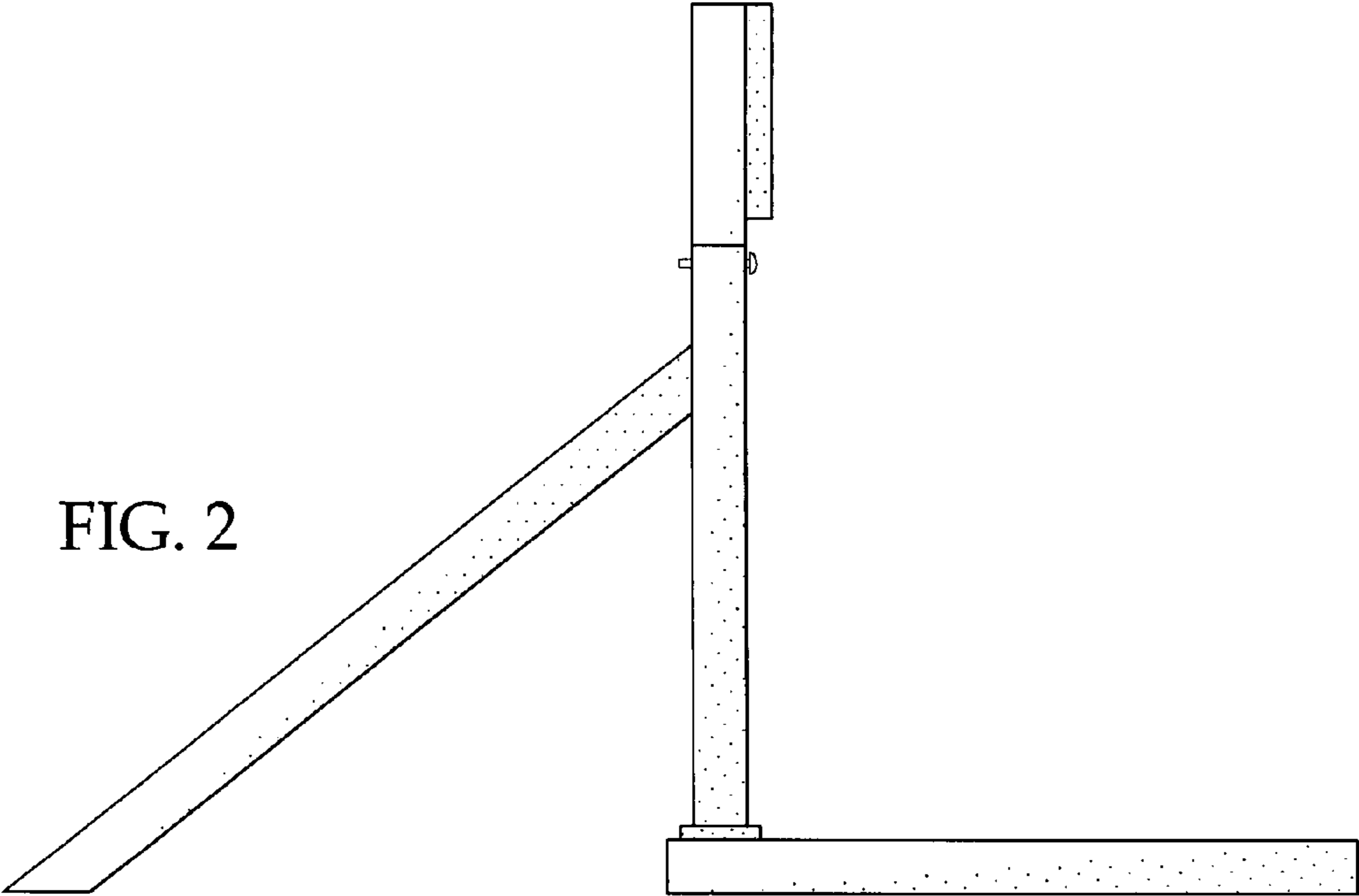
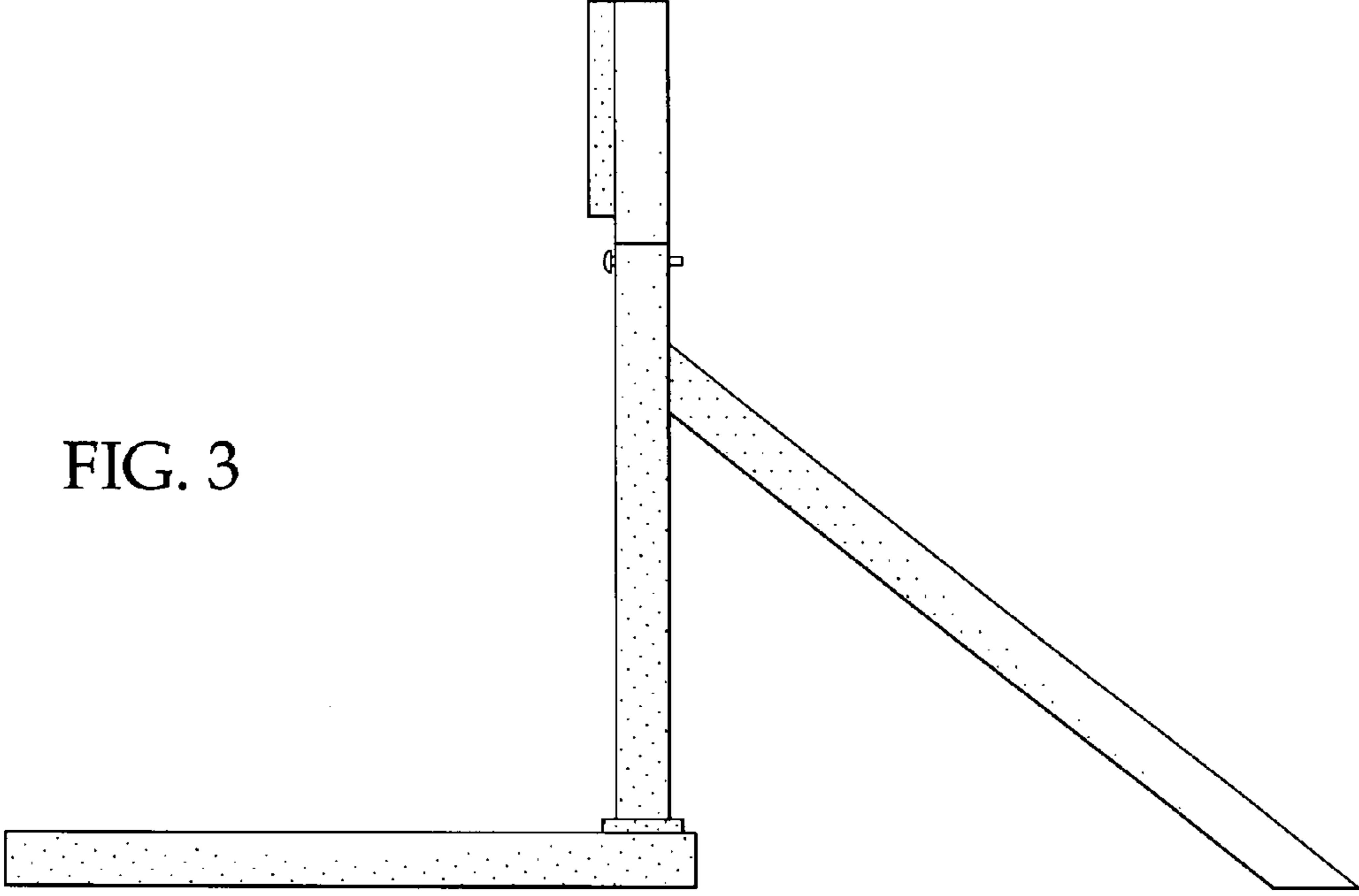

FIG. 3



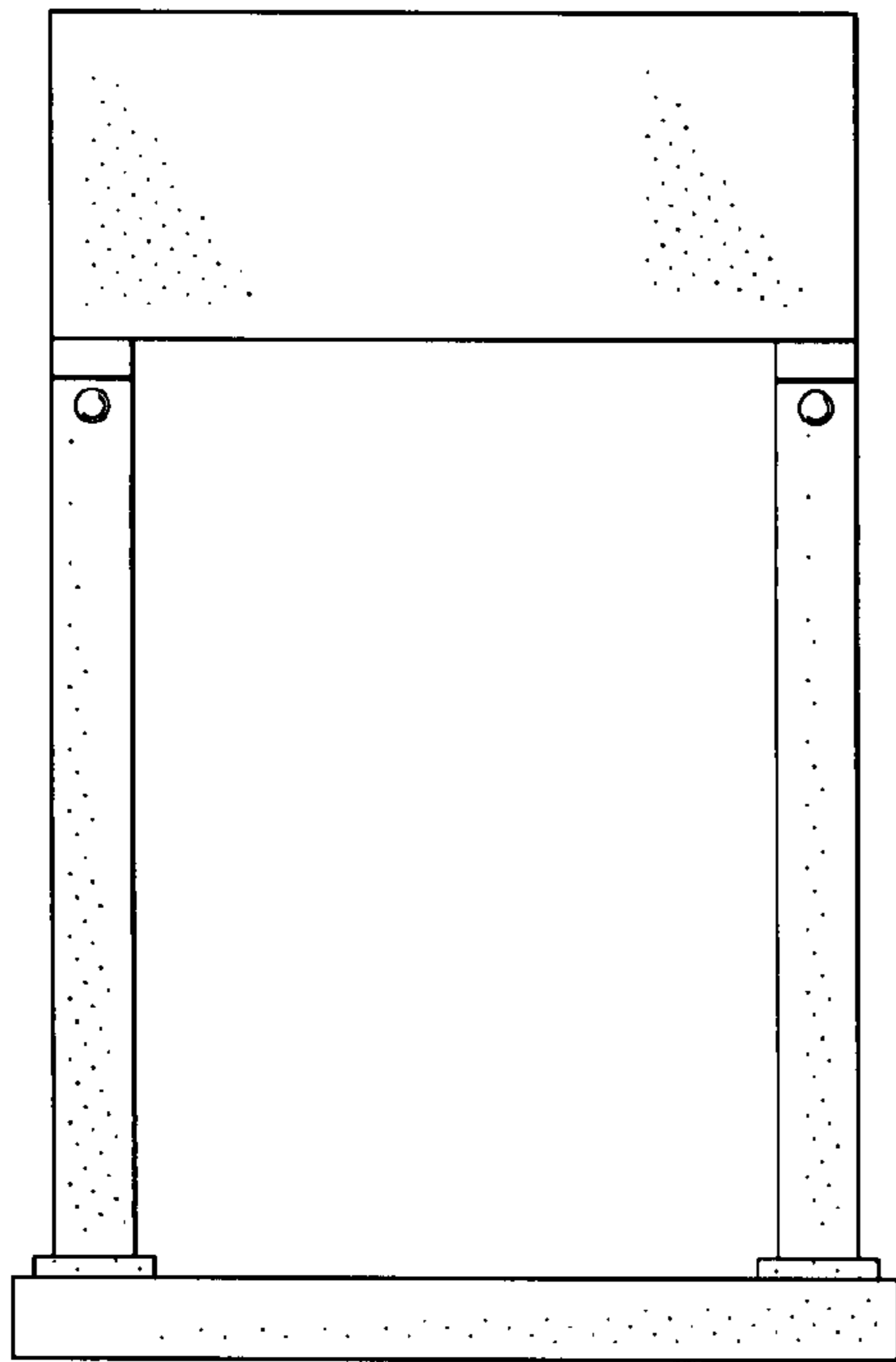

FIG. 4

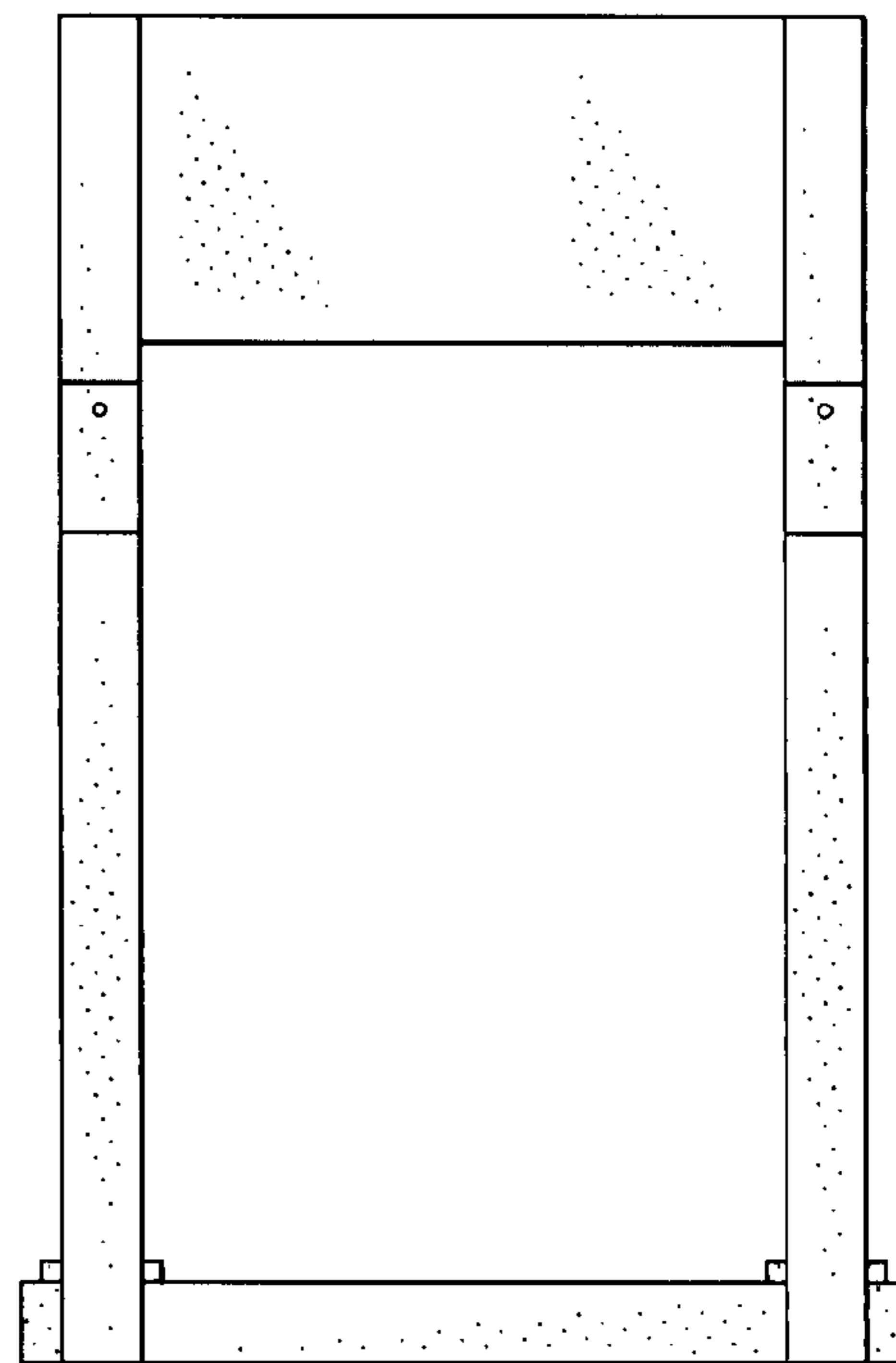

FIG. 5

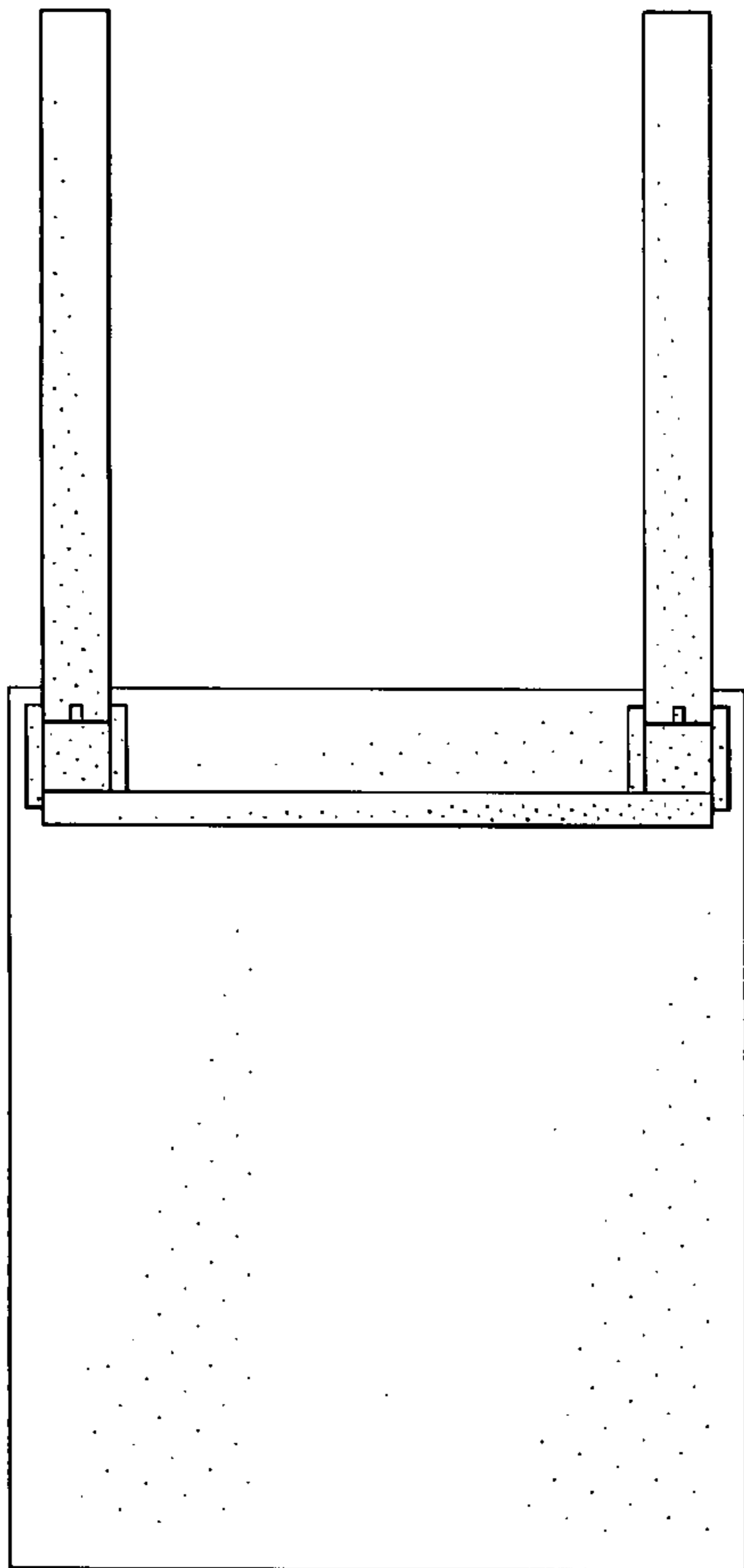

FIG. 6

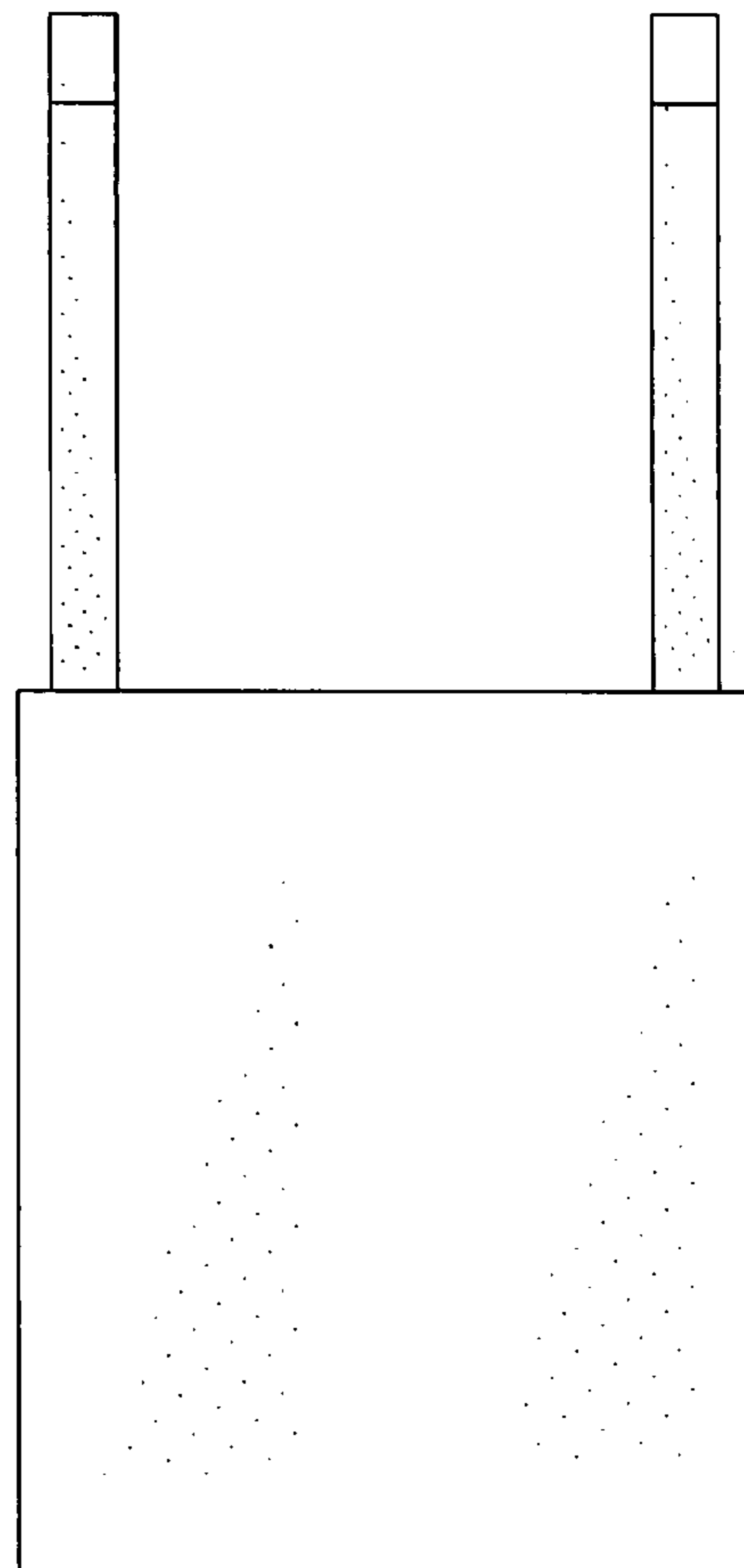

FIG. 7