



US00D545257S

(12) **United States Design Patent**  
**Pfeiffer**

(10) **Patent No.:** **US D545,257 S**

(45) **Date of Patent:** **\*\* Jun. 26, 2007**

(54) **SIDE MIRROR FOR A VEHICLE**

D516,480 S \* 3/2006 Nagashima ..... D12/187

(75) Inventor: **Peter Pfeiffer**, Boeblingen (DE)

\* cited by examiner

(73) Assignee: **DaimlerChrysler AG**, Stuttgart (DE)

*Primary Examiner*—Stacia Cadmus

(\*\*) Term: **14 Years**

(74) *Attorney, Agent, or Firm*—Crowell & Moring LLP

(21) Appl. No.: **29/253,829**

(57) **CLAIM**

(22) Filed: **Feb. 14, 2006**

The ornamental design for a side mirror for a vehicle, as shown and described.

**Related U.S. Application Data**

**DESCRIPTION**

(63) Continuation-in-part of application No. 29/245,989, filed on Jan. 4, 2006.

FIG. 1 is a front perspective view of a first embodiment of a side mirror for a vehicle according to my novel design;

(30) **Foreign Application Priority Data**

FIG. 2 is a top view thereof;

Jul. 5, 2005 (DE) ..... 40503451

FIG. 3 is a bottom view thereof;

Nov. 30, 2005 (DE) ..... 40506110

FIG. 4 is a front view thereof;

(51) **LOC (8) Cl.** ..... **12-16**

FIG. 5 is a side view thereof;

(52) **U.S. Cl.** ..... **D12/187**

FIG. 6 is a rear view thereof.

(58) **Field of Classification Search** ..... D12/187-189;  
359/838-851, 855-868, 871-881; 248/475.1,  
248/476, 480-481, 485-487

FIG. 7 is a front perspective view of a second embodiment of the side mirror for a vehicle according to my novel design;

See application file for complete search history.

FIG. 8 is a top view thereof;

(56) **References Cited**

FIG. 9 is a bottom view thereof;

**U.S. PATENT DOCUMENTS**

D410,421 S *	6/1999	Pfeiffer	.....	D12/187
D430,839 S *	9/2000	Goplen	.....	D12/187
D445,386 S *	7/2001	Sacco et al.	.....	D12/187
D463,342 S *	9/2002	Sinkwitz	.....	D12/187
D496,616 S *	9/2004	Hoelzel et al.	.....	D12/187
D500,273 S *	12/2004	Otto et al.	.....	D12/187
D500,274 S *	12/2004	Pfeiffer	.....	D12/187
D506,169 S *	6/2005	Pfeiffer et al.	.....	D12/187
D506,962 S *	7/2005	Kulla	.....	D12/187
D511,127 S *	11/2005	Elmitt	.....	D12/187

FIG. 10 is a front view thereof;

FIG. 11 is a side view thereof; and

FIG. 12 is a rear view thereof; and,

FIG. 13 is a perspective view of the side mirror for a vehicle according to my novel design, providing a possible environment of the design.

The broken lines are for illustrative purposes only and form no part of the claimed design.

**1 Claim, 7 Drawing Sheets**

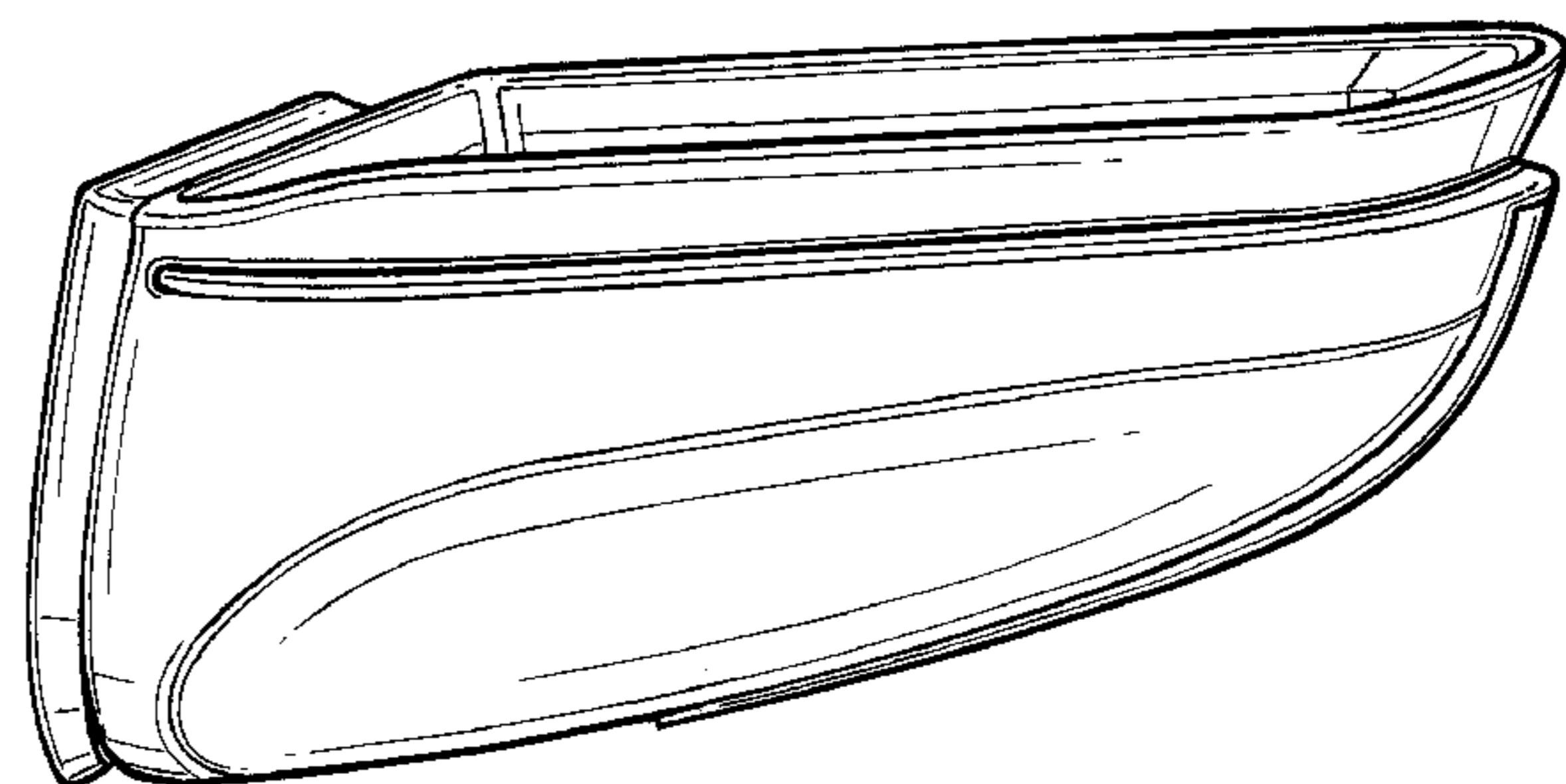
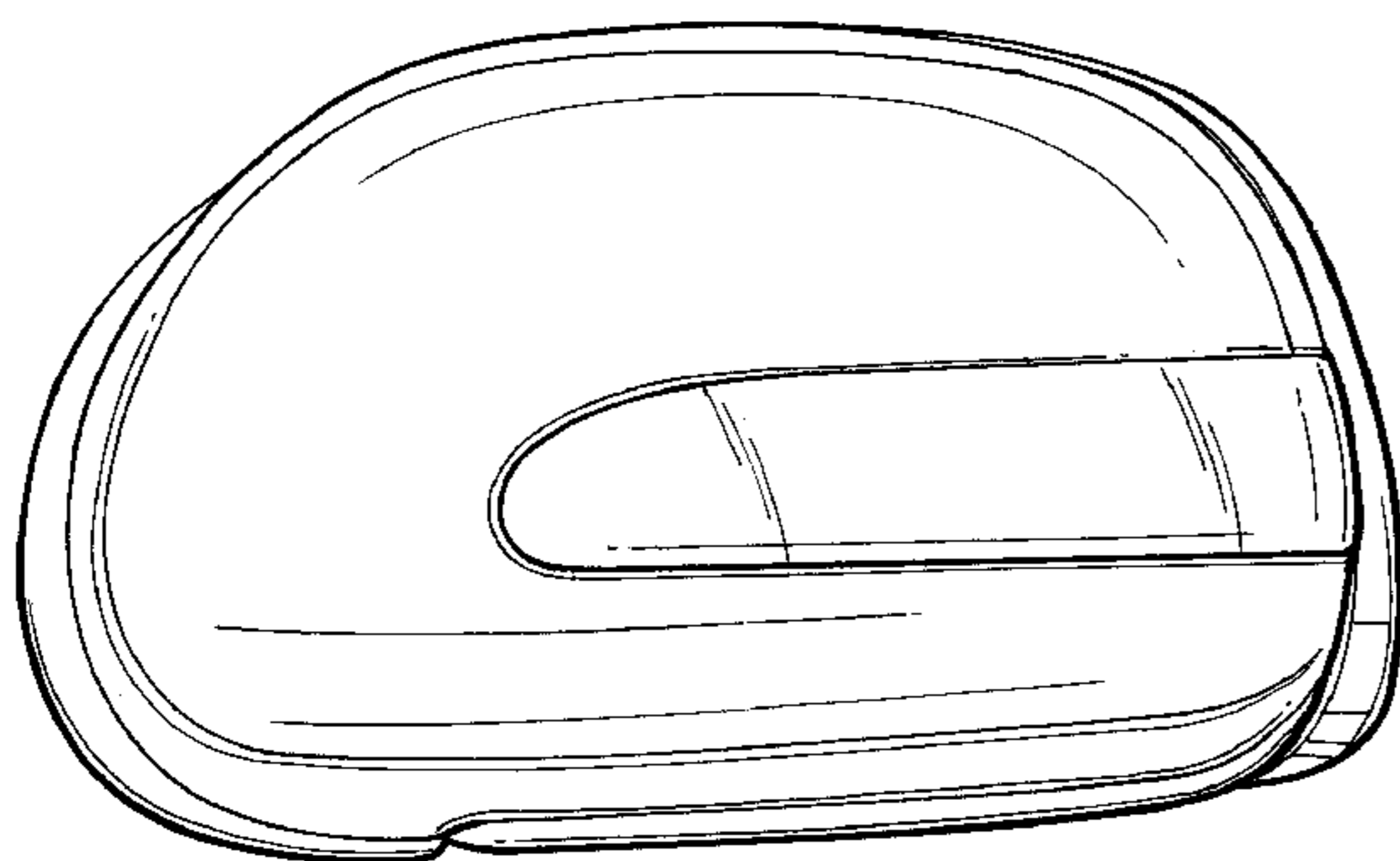

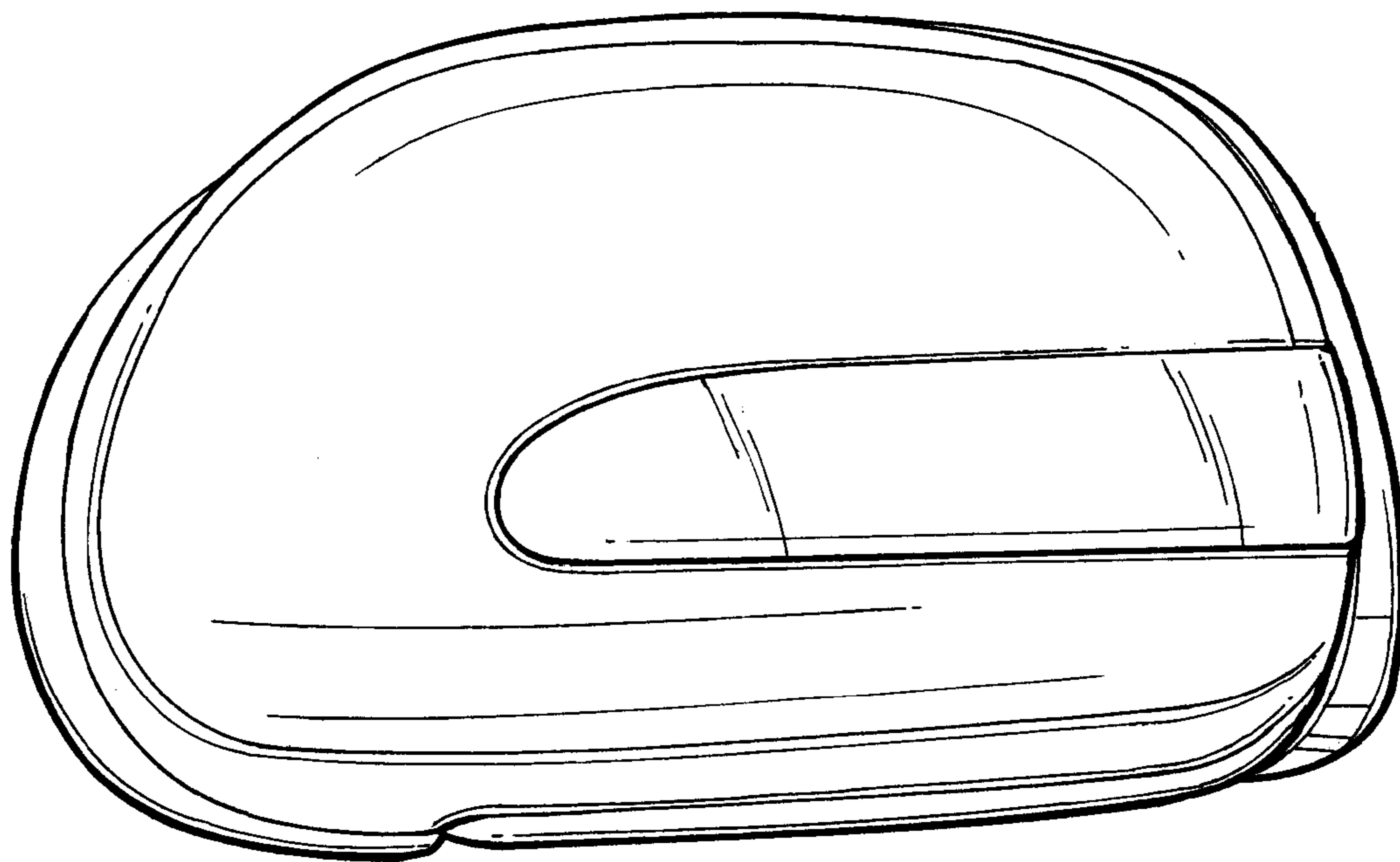

FIG. 1

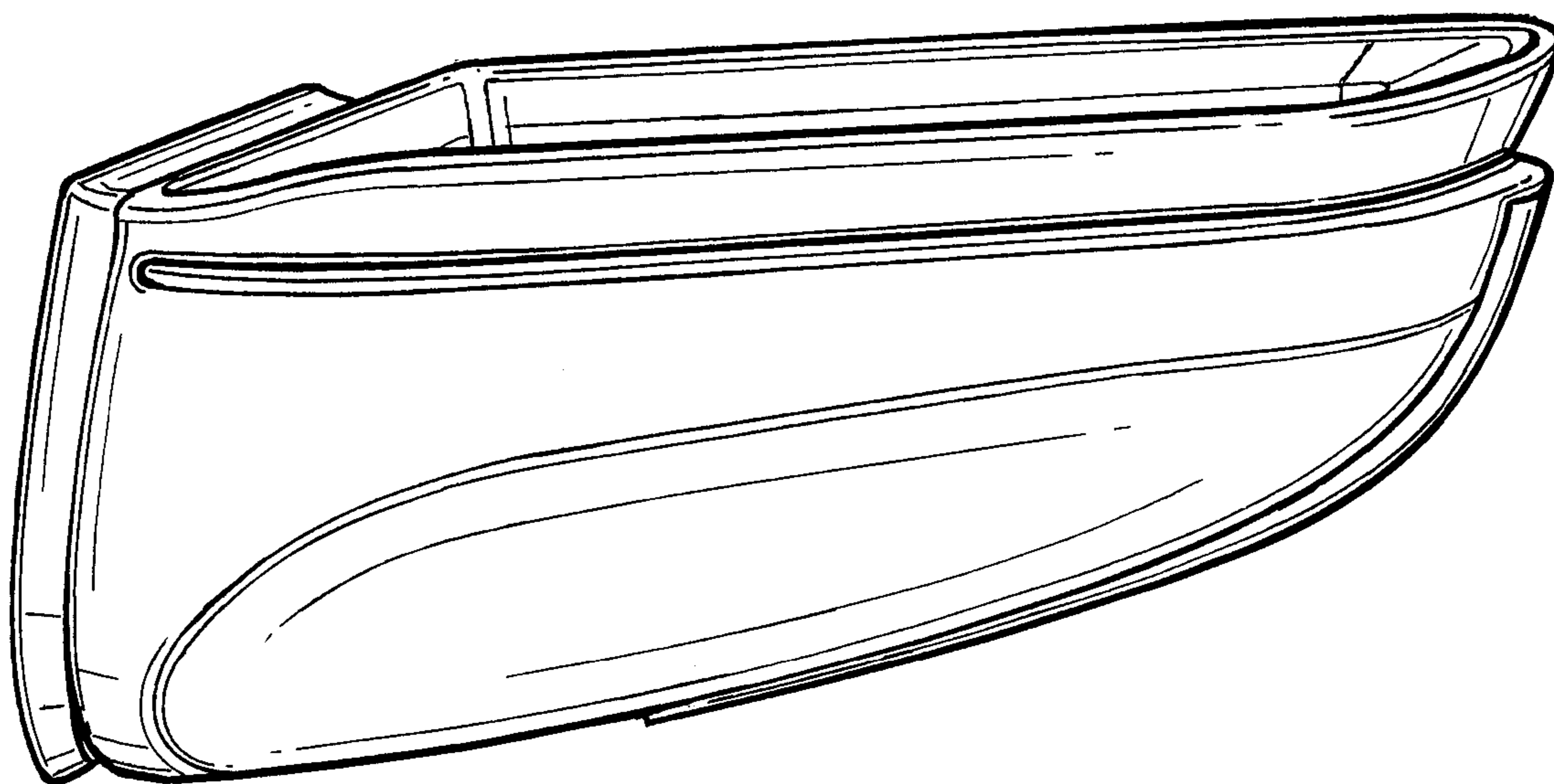

FIG. 2

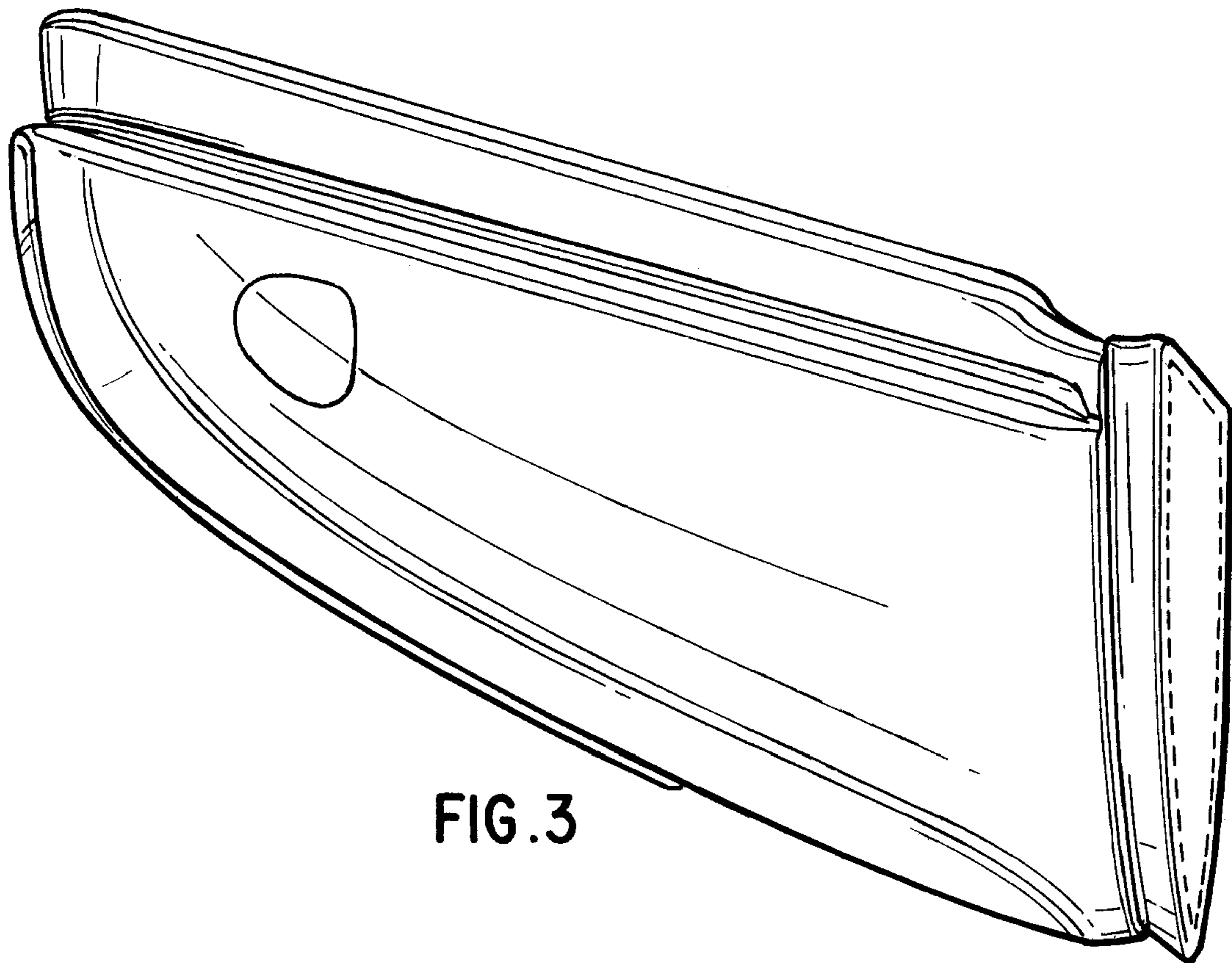

FIG. 3

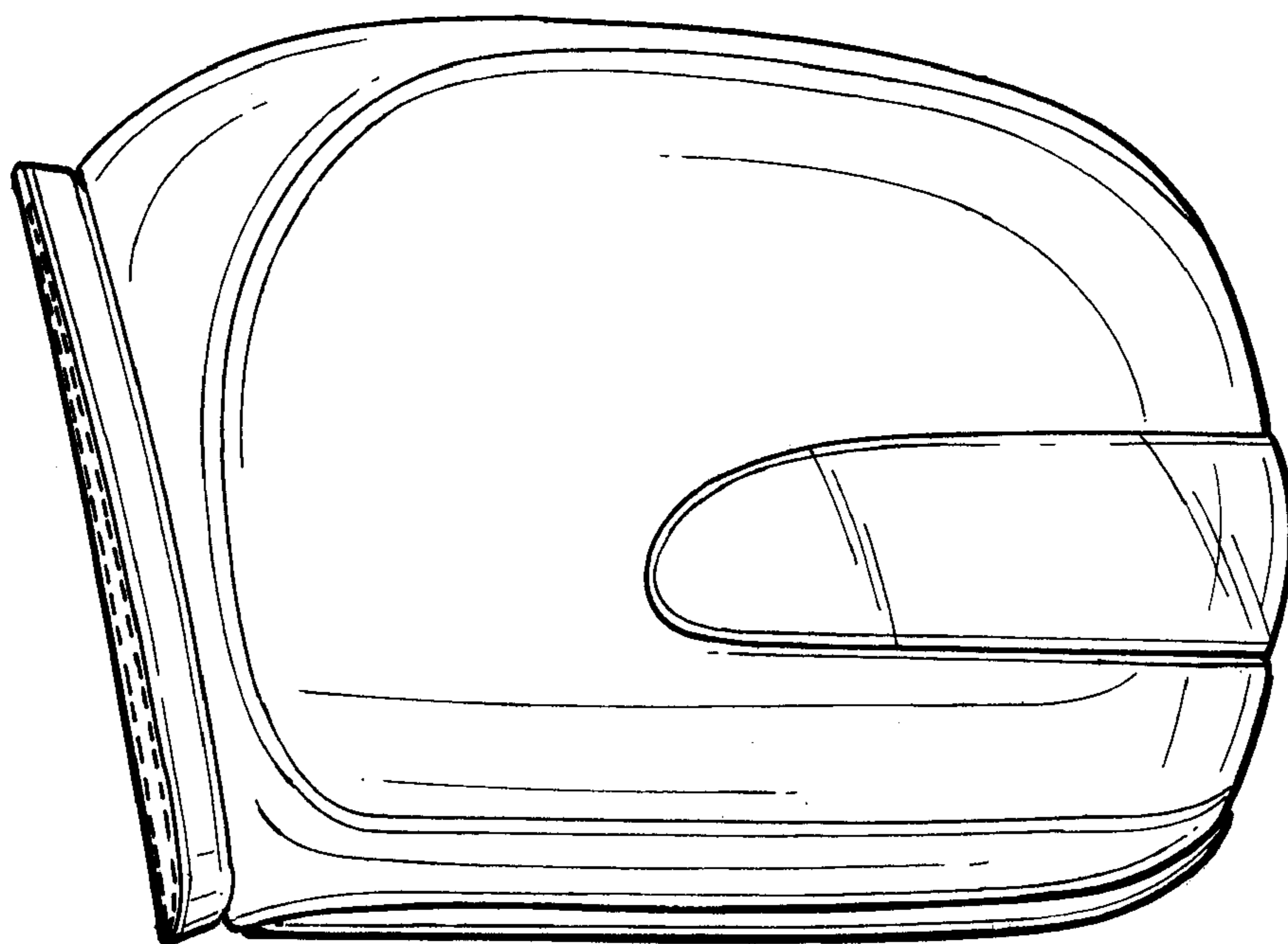

FIG. 4

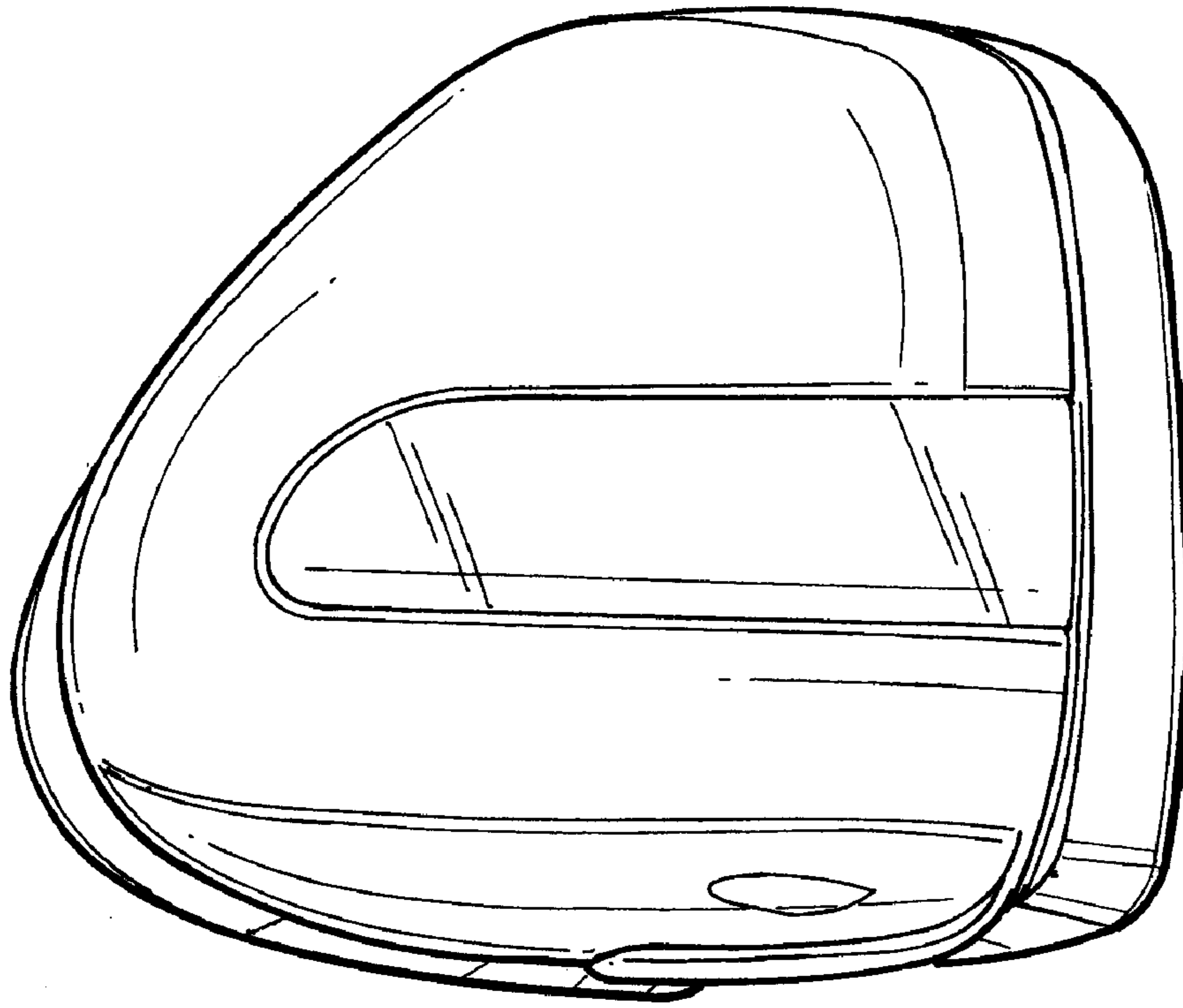

FIG. 5

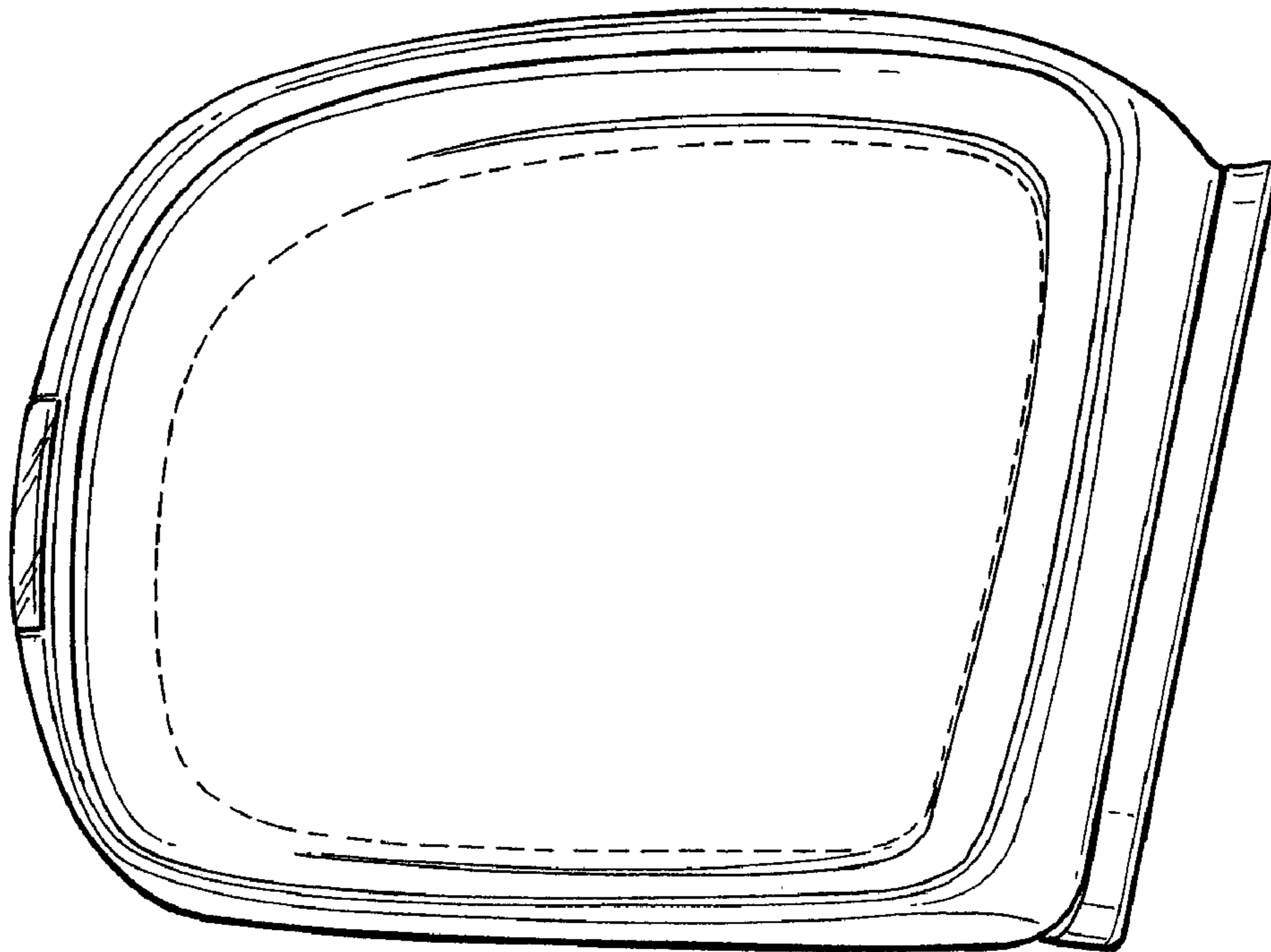

FIG. 6

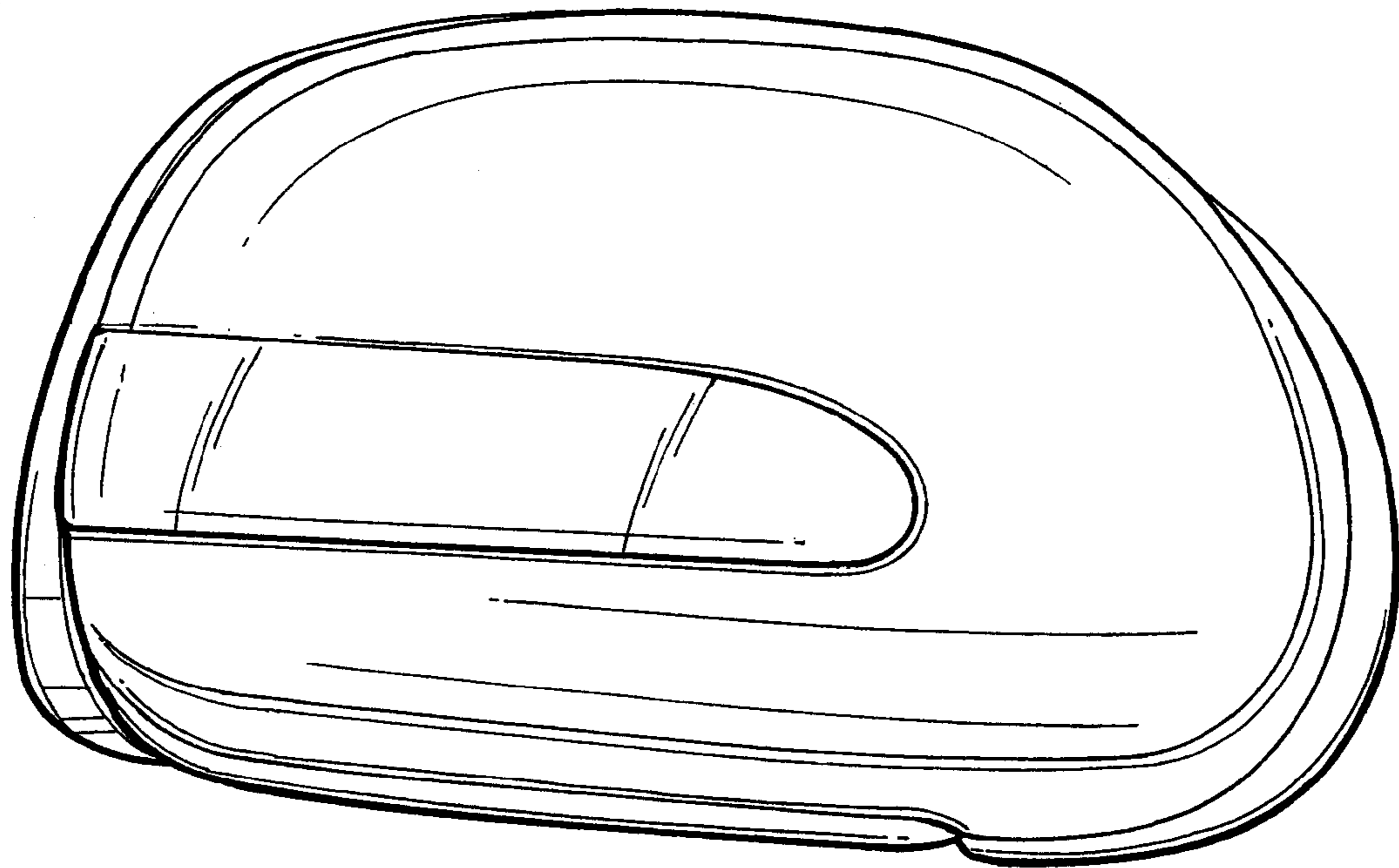

FIG. 7

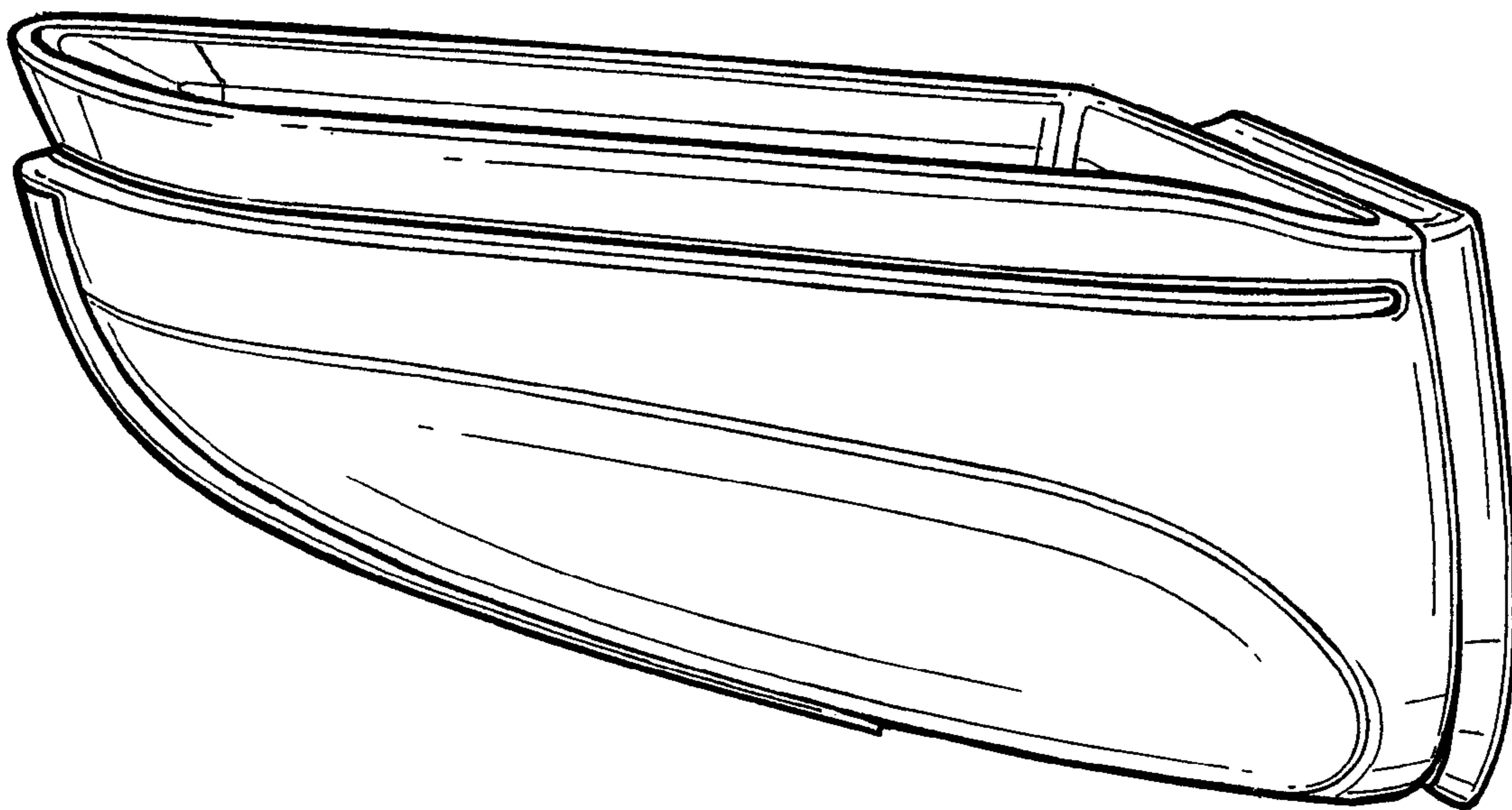

FIG. 8

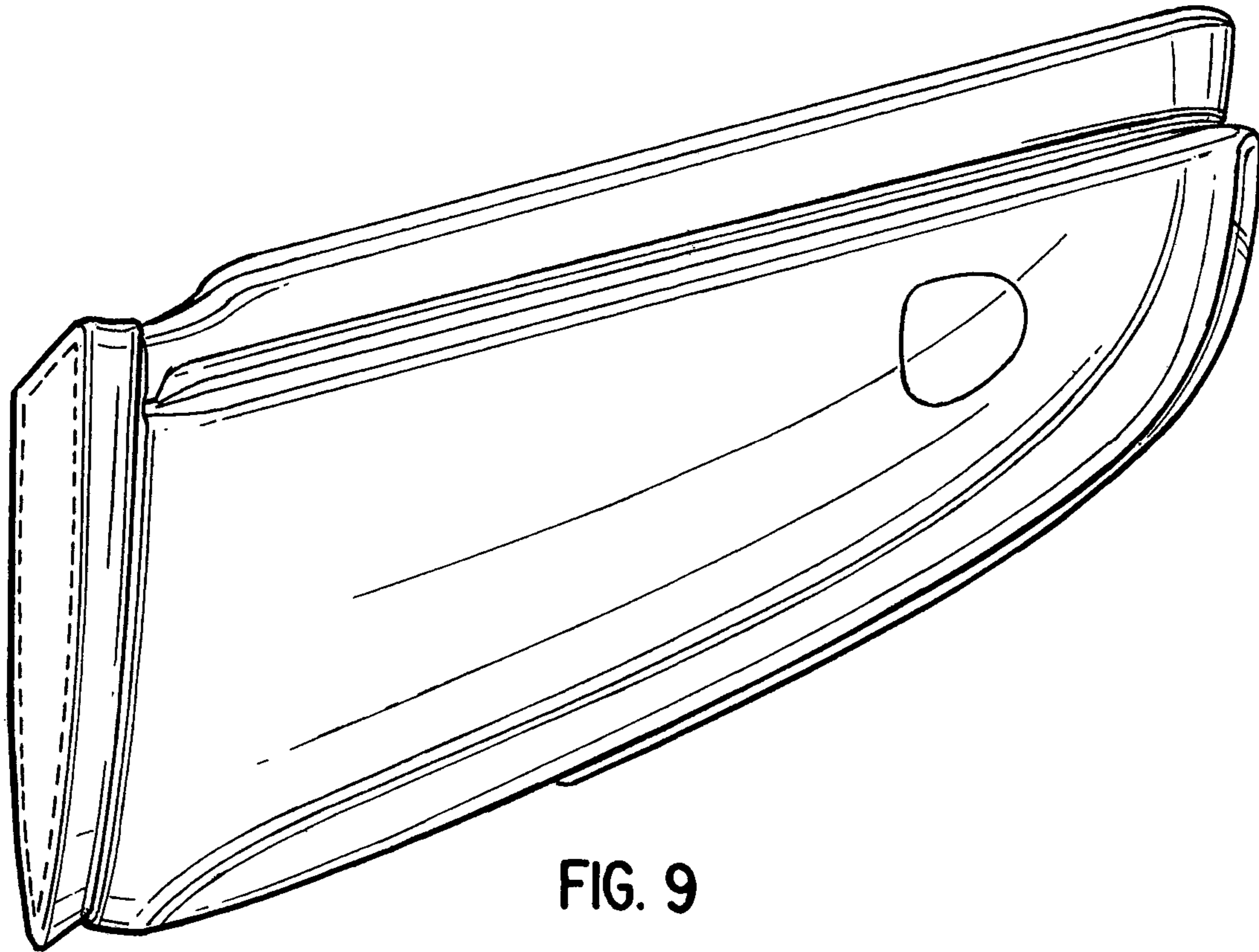

FIG. 9

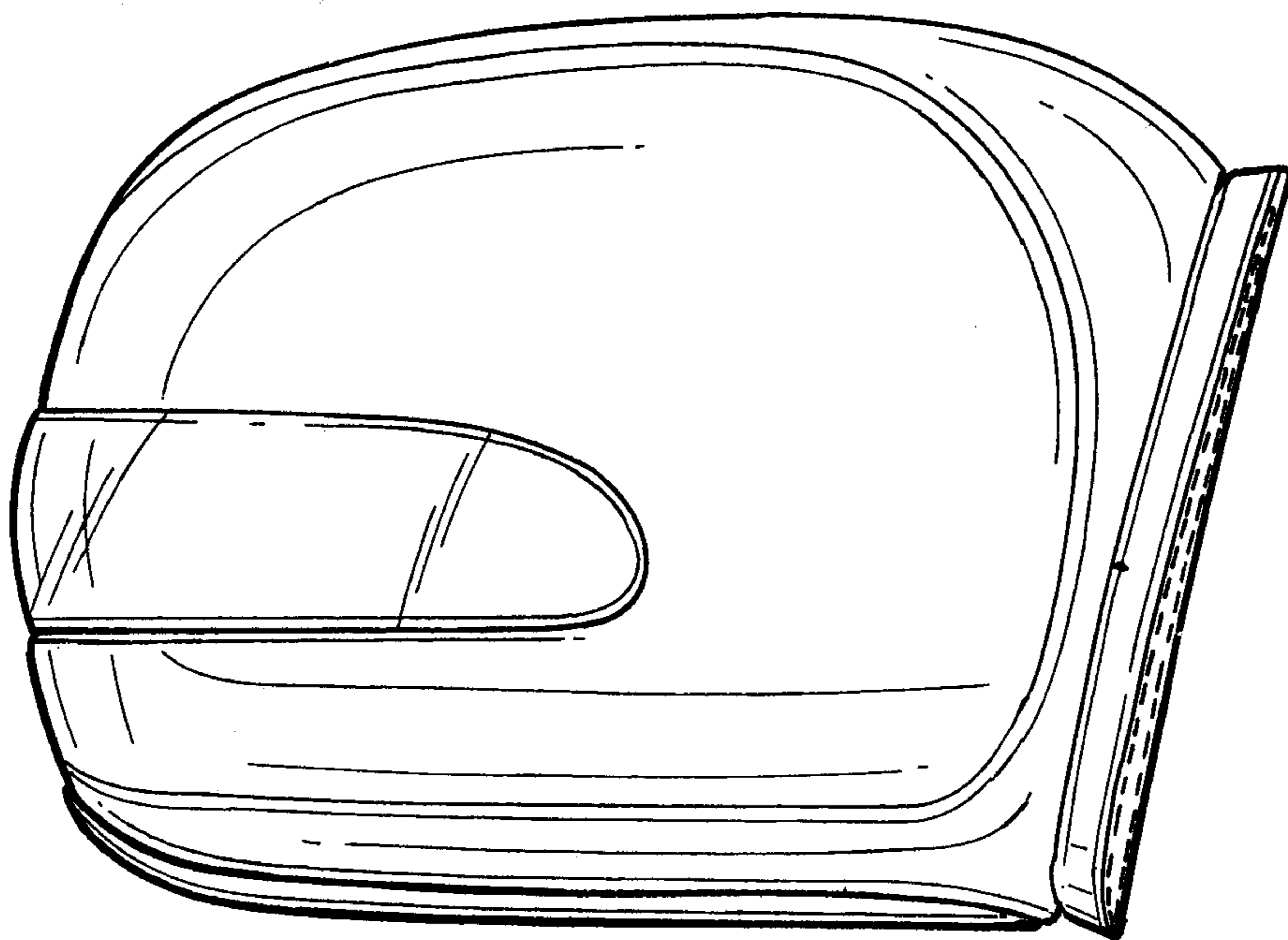

FIG. 10

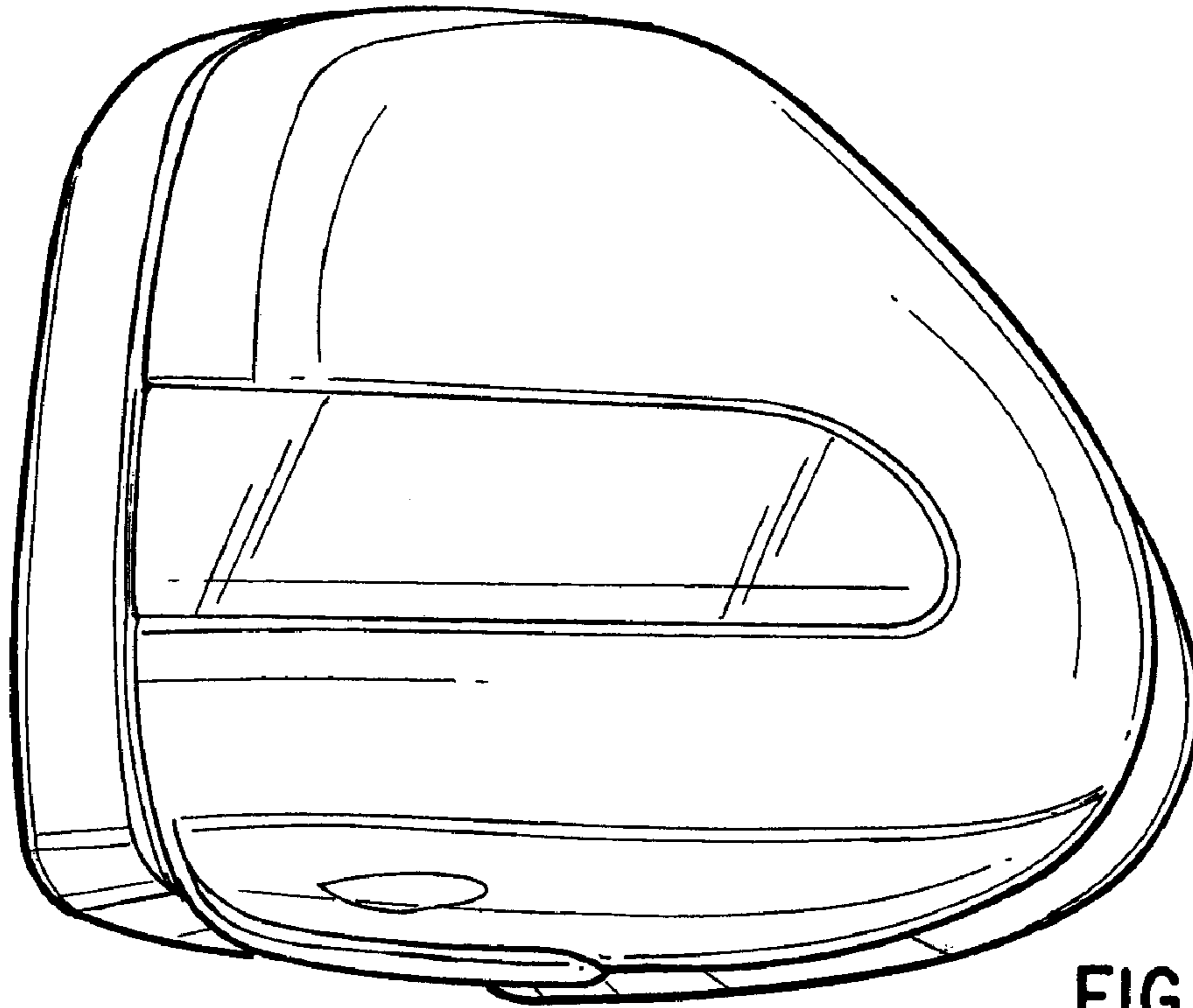

FIG. 11

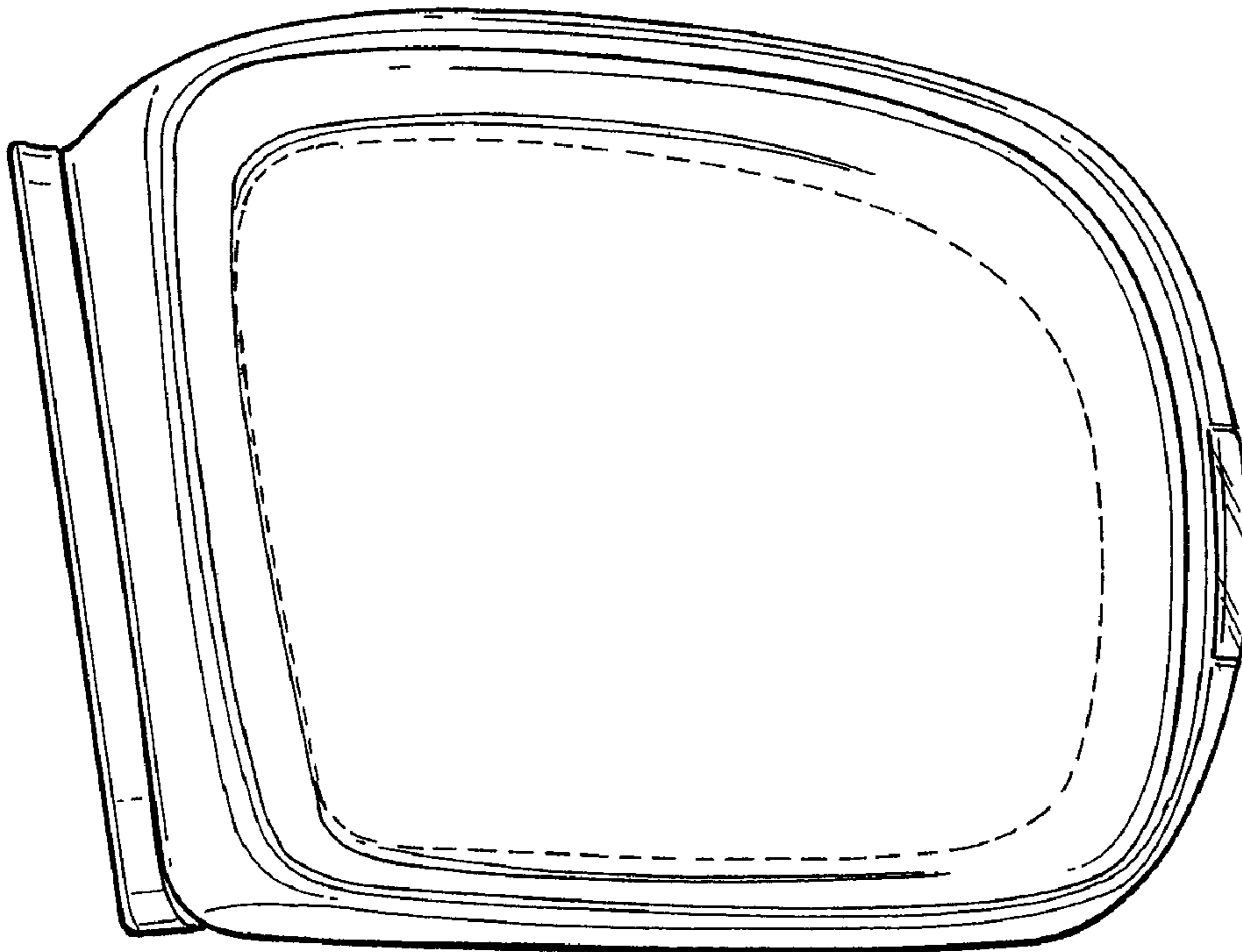

FIG. 12

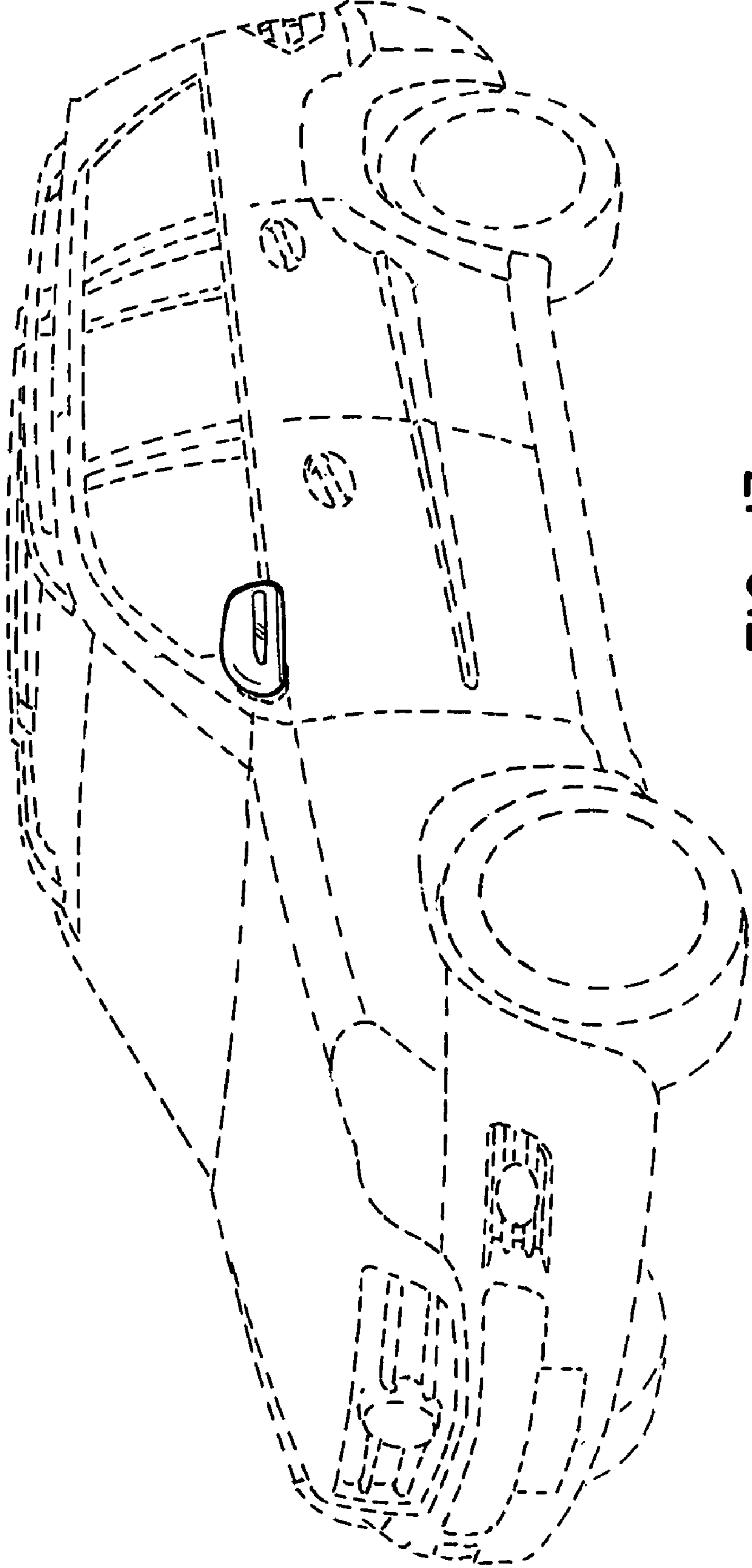

FIG. 13