

US00D545253S

(12) **United States Design Patent**  
**Jones**

(10) **Patent No.:** **US D545,253 S**

(45) **Date of Patent:** **\*\* Jun. 26, 2007**

(54) **TRUCK FENDER**

D524,202 S \* 7/2006 Devitt ..... D12/184  
D524,203 S \* 7/2006 Ichikawa et al. .... D12/184

(75) Inventor: **David A. Jones**, West Middlesex, PA  
(US)

\* cited by examiner

(73) Assignee: **Jones Performance Products, Inc.**,  
West Middlesex, PA (US)

*Primary Examiner*—Melody N. Brown  
(74) *Attorney, Agent, or Firm*—James R. Williams

(\*\*) Term: **14 Years**

(57) **CLAIM**

(21) Appl. No.: **29/261,759**

The ornamental design for a truck fender, as shown and described.

(22) Filed: **Jun. 20, 2006**

**DESCRIPTION**

(51) **LOC (8) Cl.** ..... **12-16**

(52) **U.S. Cl.** ..... **D12/184; D12/106**

(58) **Field of Classification Search** ..... D12/184,  
D12/106, 96, 93; 280/414.1–414.3, 847–849  
See application file for complete search history.

FIG. 1 is a perspective view of the design, it being understood that the broken lines are for illustrative purposes only and form no part of the claimed design;

FIG. 2 is an side elevation view of a truck fender;

FIG. 3 is an opposite side elevation view of a truck fender;

FIG. 4 is a top plan view of the design;

FIG. 5 is a bottom plan view of the design;

FIG. 6 is a front view of the design; and,

FIG. 7 is a rear view of the design.

(56) **References Cited**

**U.S. PATENT DOCUMENTS**

D299,019 S	12/1988	McKinnon	
D403,639 S	* 1/1999	Gale et al.	..... D12/184
D422,251 S	4/2000	Bader et al.	
D450,277 S	11/2001	Onopa	
D497,581 S	10/2004	Conway	

**1 Claim, 3 Drawing Sheets**

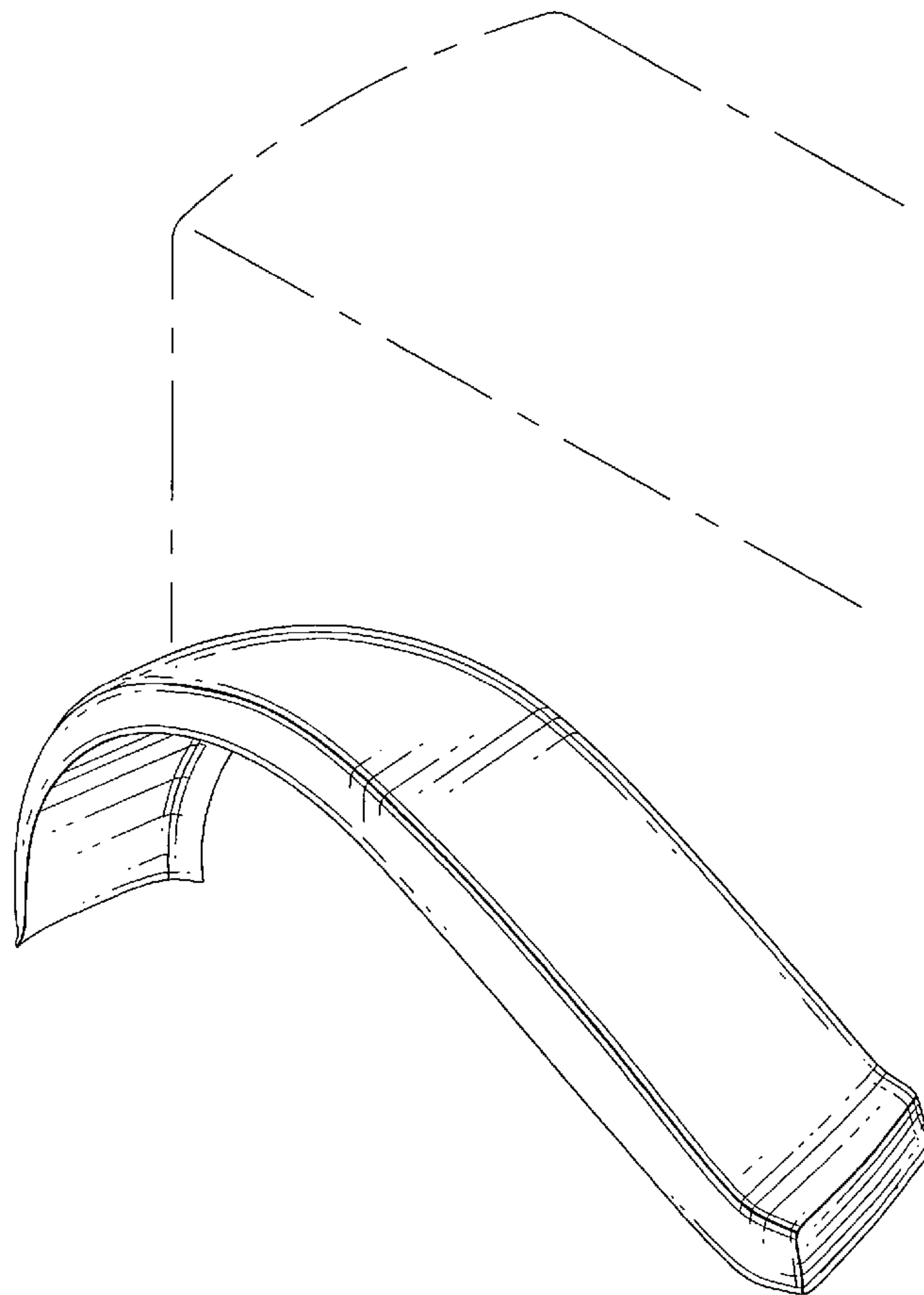

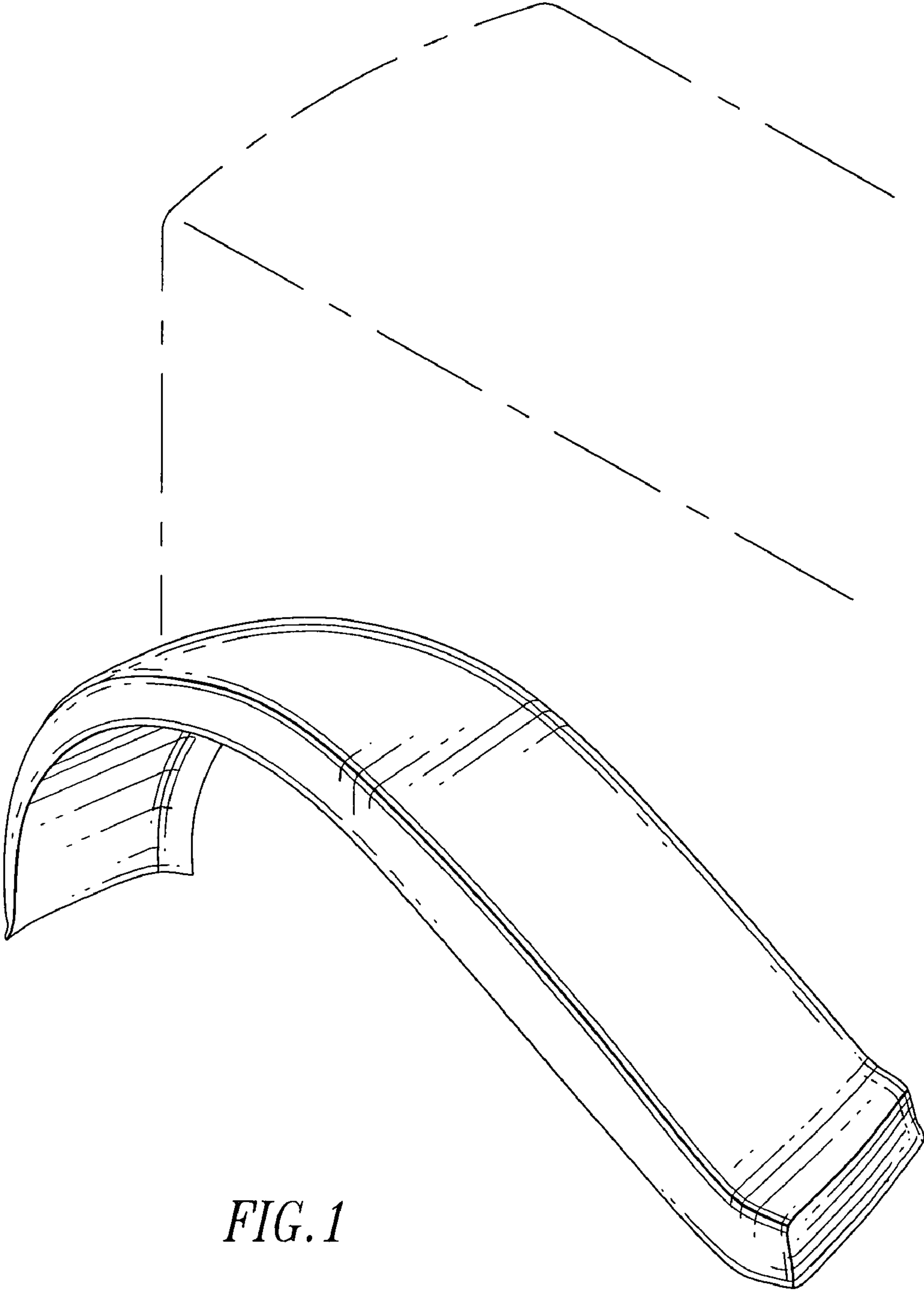
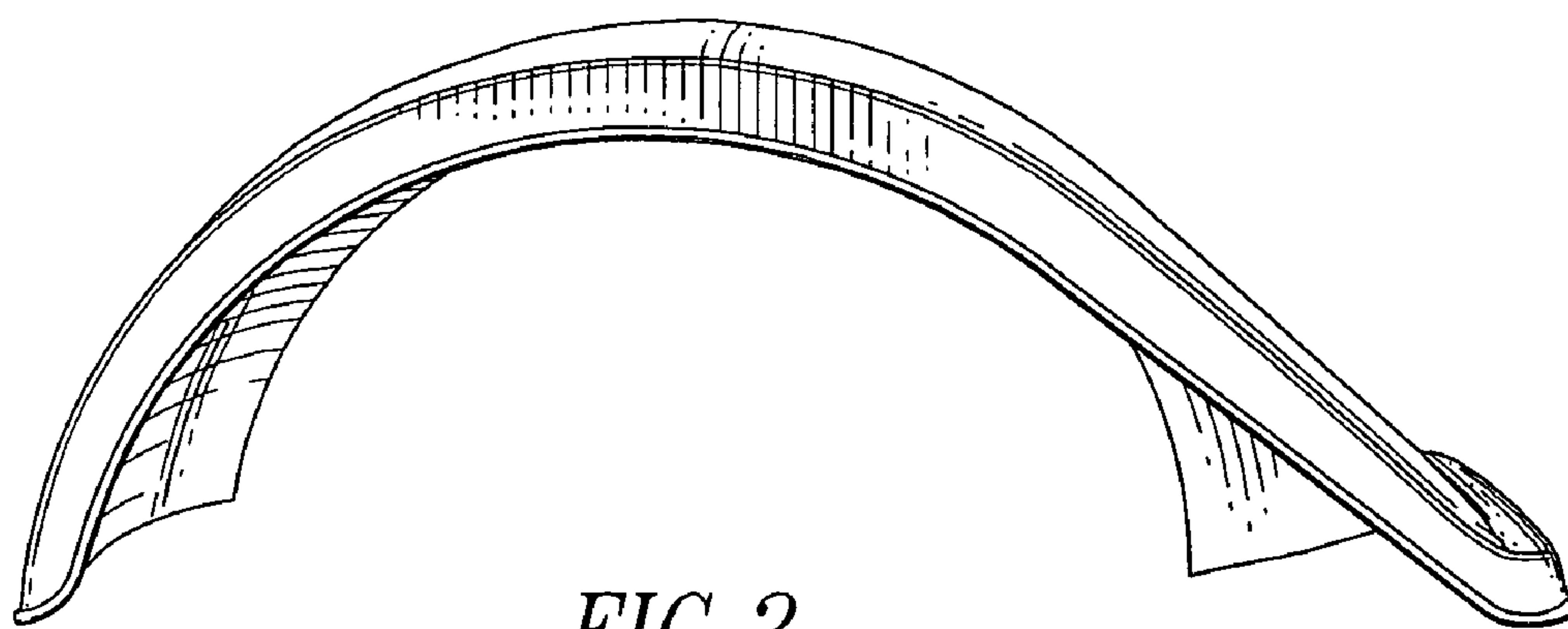
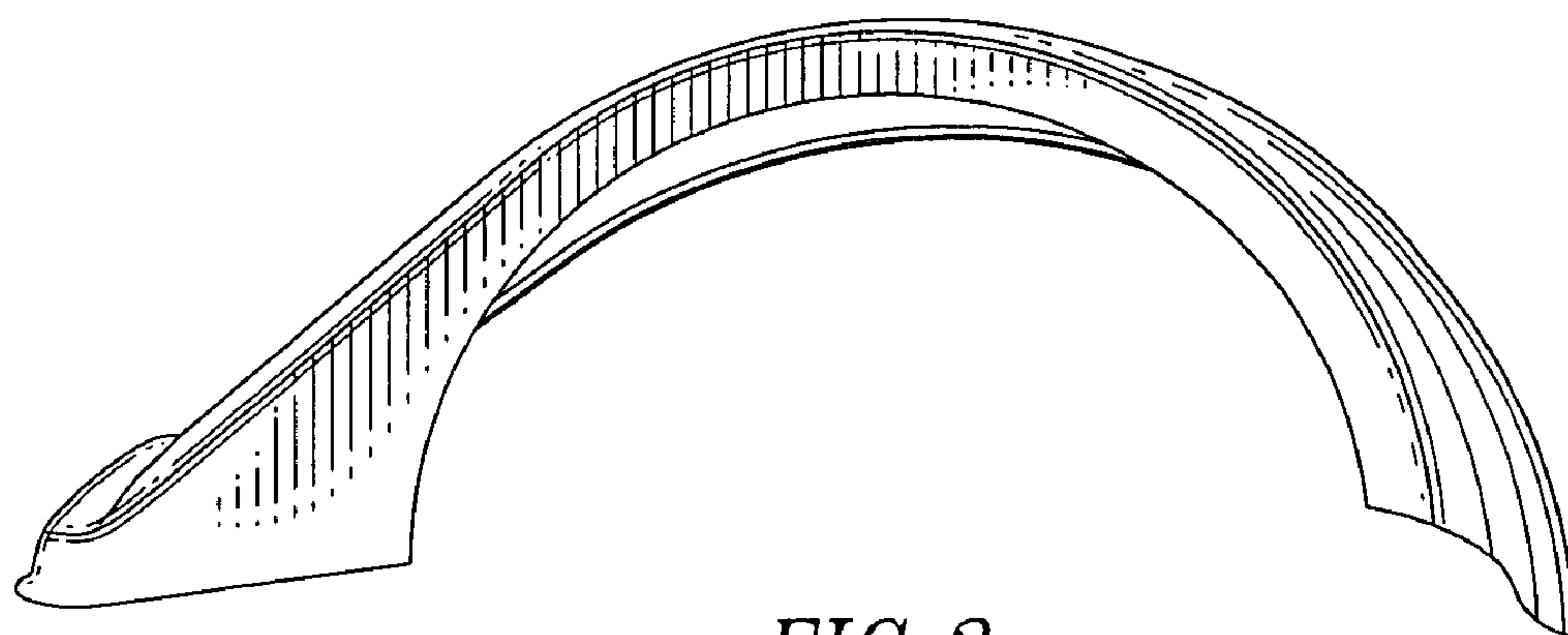

FIG. 1



*FIG. 2*



*FIG. 3*

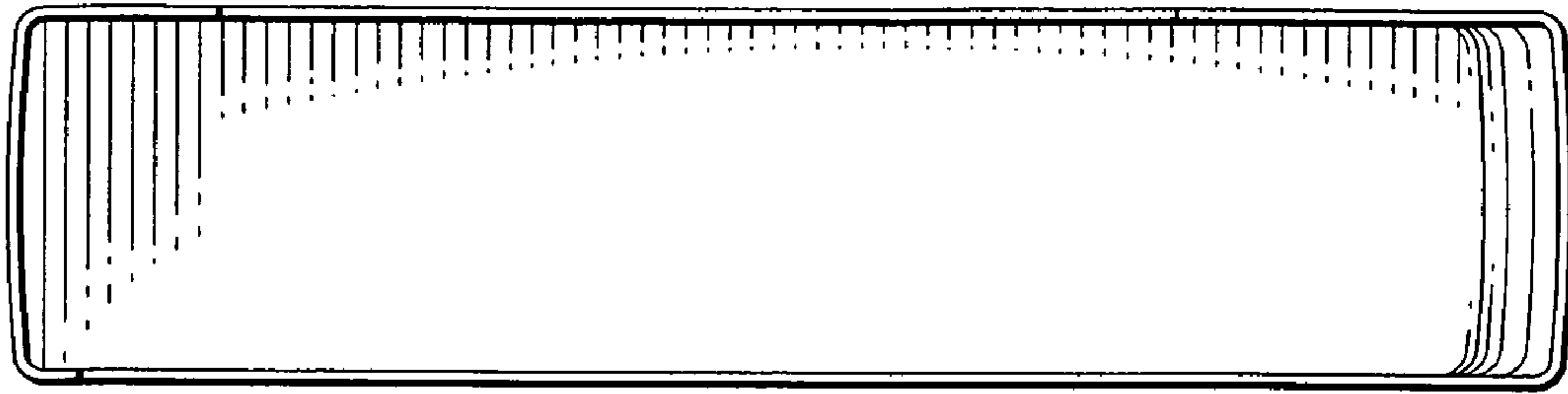

*FIG. 4*

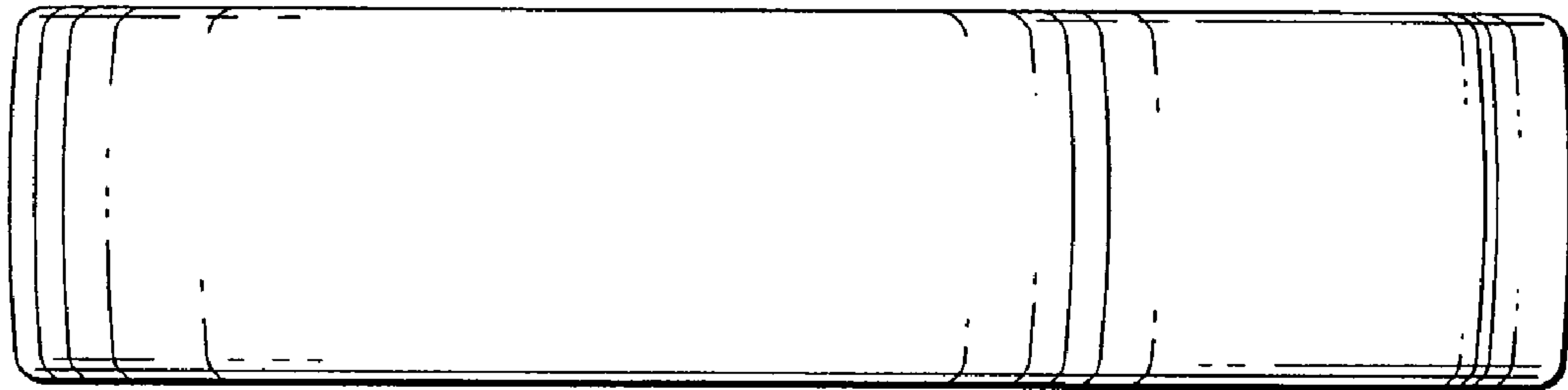

*FIG. 5*

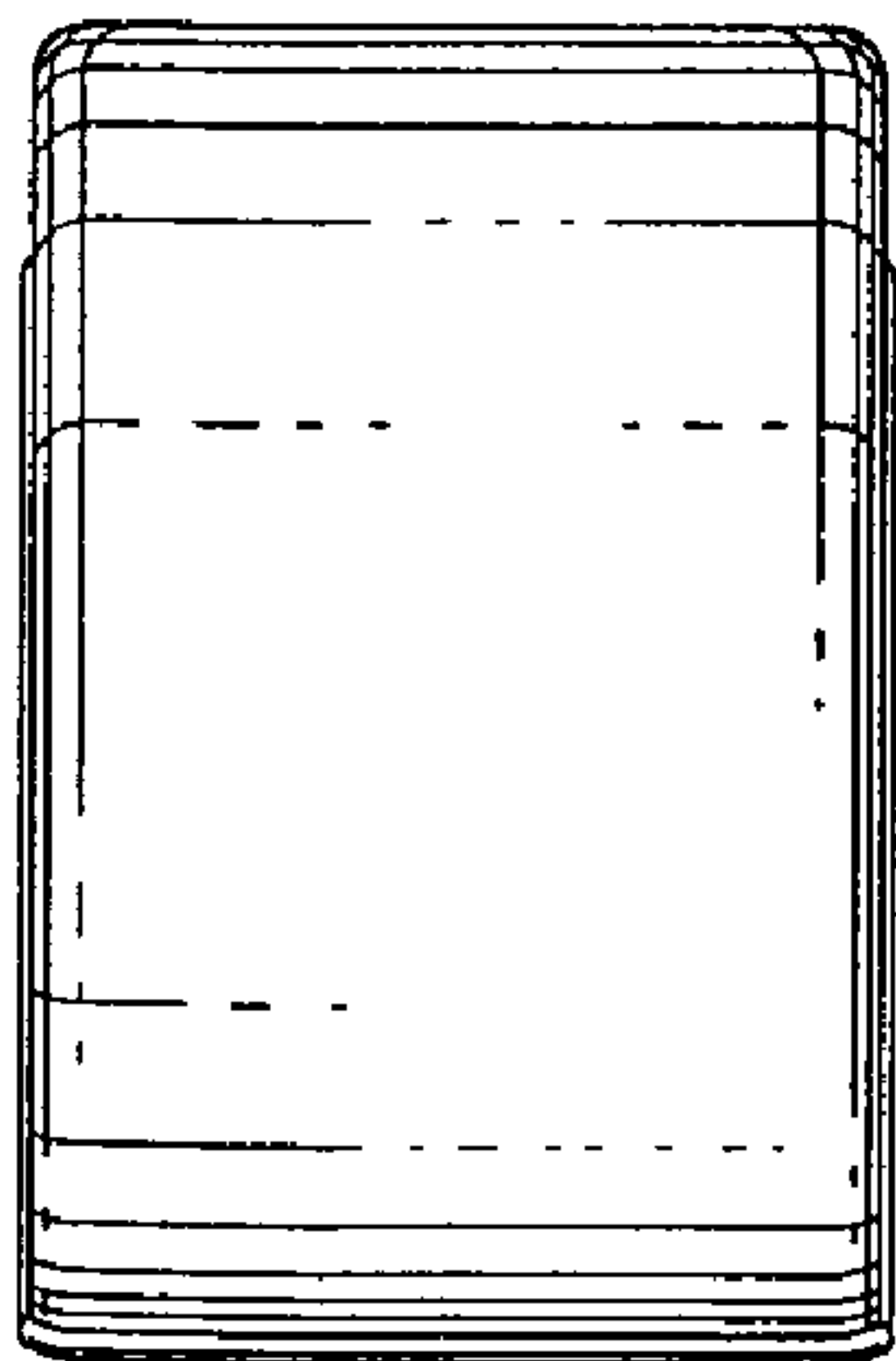

*FIG. 6*

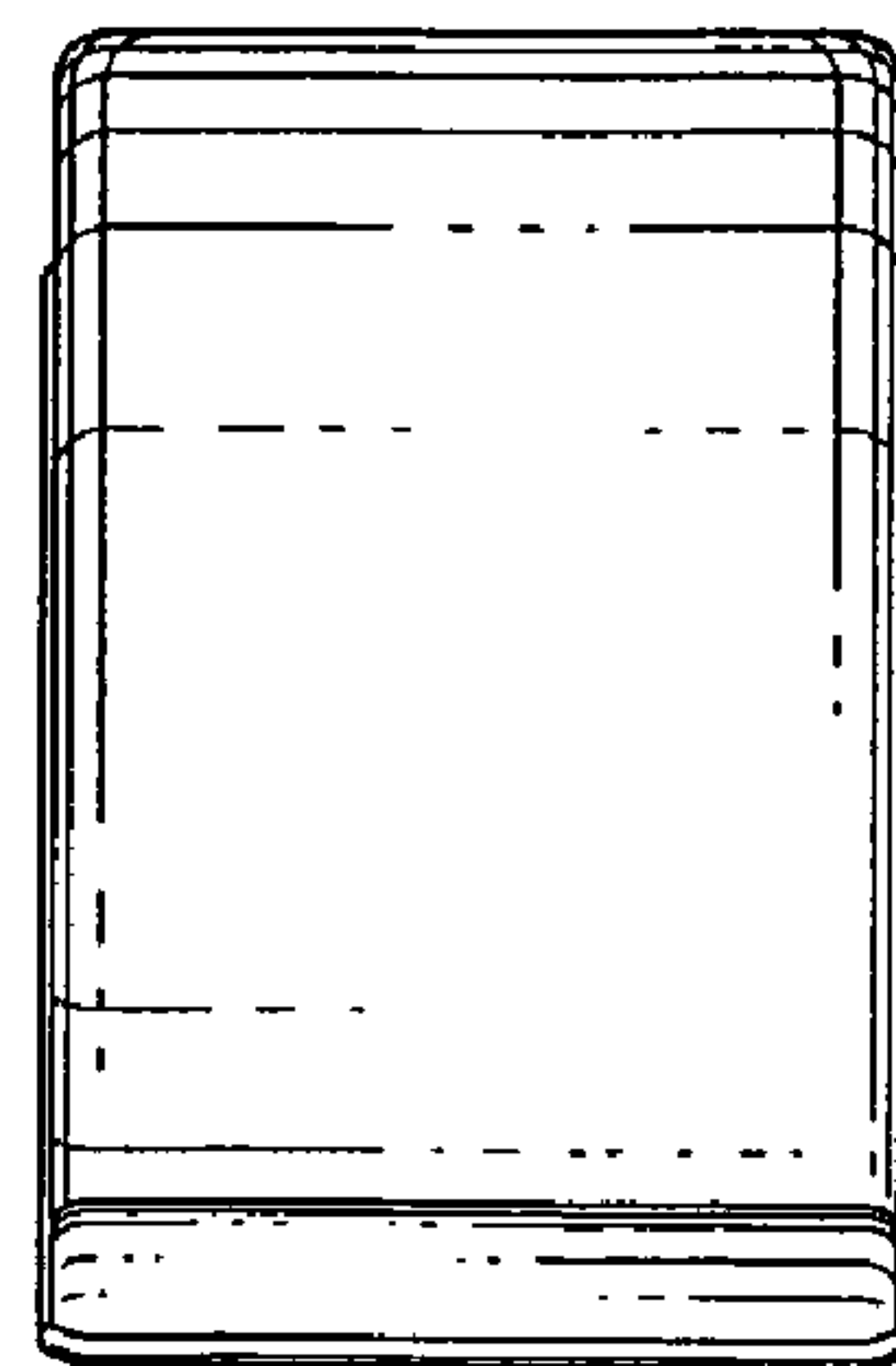

*FIG. 7*