

US00D545246S

(12) **United States Design Patent**  
**Kroeker**

(10) **Patent No.:** **US D545,246 S**

(45) **Date of Patent:** **\*\* Jun. 26, 2007**

(54) **VEHICLE SUSPENSION CONTROL ARM**

(76) Inventor: **Kent L. Kroeker**, P.O. Box 2628,  
Valley Center, CA (US) 92082

(\*\*) Term: **14 Years**

(21) Appl. No.: **29/240,120**

(22) Filed: **Oct. 7, 2005**

(51) **LOC (8) Cl.** ..... **12-16**

(52) **U.S. Cl.** ..... **D12/159**

(58) **Field of Classification Search** ..... D12/159-161,  
D12/400, 110, 111, 114; 280/5.5-5.524; D15/148;  
301/124.1-137; 267/183-259, 1-37.4, 38-53,  
267/260-291, 64.11-64.28, 66-98

See application file for complete search history.

(56) **References Cited**

U.S. PATENT DOCUMENTS

D58,959 S	*	9/1921	Hudson	.....	D12/159
D223,024 S	*	2/1972	Wendland	.....	D12/159
D289,277 S	*	4/1987	Horberg et al.	.....	D12/160
D385,835 S	*	11/1997	Webster	.....	D12/159
D402,617 S	*	12/1998	Adams, III	.....	D12/160

\* cited by examiner

*Primary Examiner*—Doris Clark

*Assistant Examiner*—Michael Pratt

(74) *Attorney, Agent, or Firm*—Loyal McKinley Hanson

(57) **CLAIM**

The ornamental design for vehicle suspension control arm, as shown and described.

**DESCRIPTION**

FIG. 1 is a perspective view of a vehicle suspension control arm showing my new design;

FIG. 2 is a right side elevation view thereof;

FIG. 3 is a top plan view thereof;

FIG. 4 is a front elevation view thereof;

FIG. 5 is a back elevation view thereof;

FIG. 6 is left side elevation view thereof;

FIG. 7 is a bottom plan view thereof;

FIG. 8 is a reduced right side elevation view thereof; in a first or lower control arm location,

FIG. 9 is a perspective view of a second embodiment of a vehicle suspension control arm; in an upper control arm location; and,

FIG. 10 is a reduced right side elevation view thereof.

The broken line showing or portions of a vehicle is for illustrative purposes only and forms no part of the claimed design.

**1 Claim, 6 Drawing Sheets**

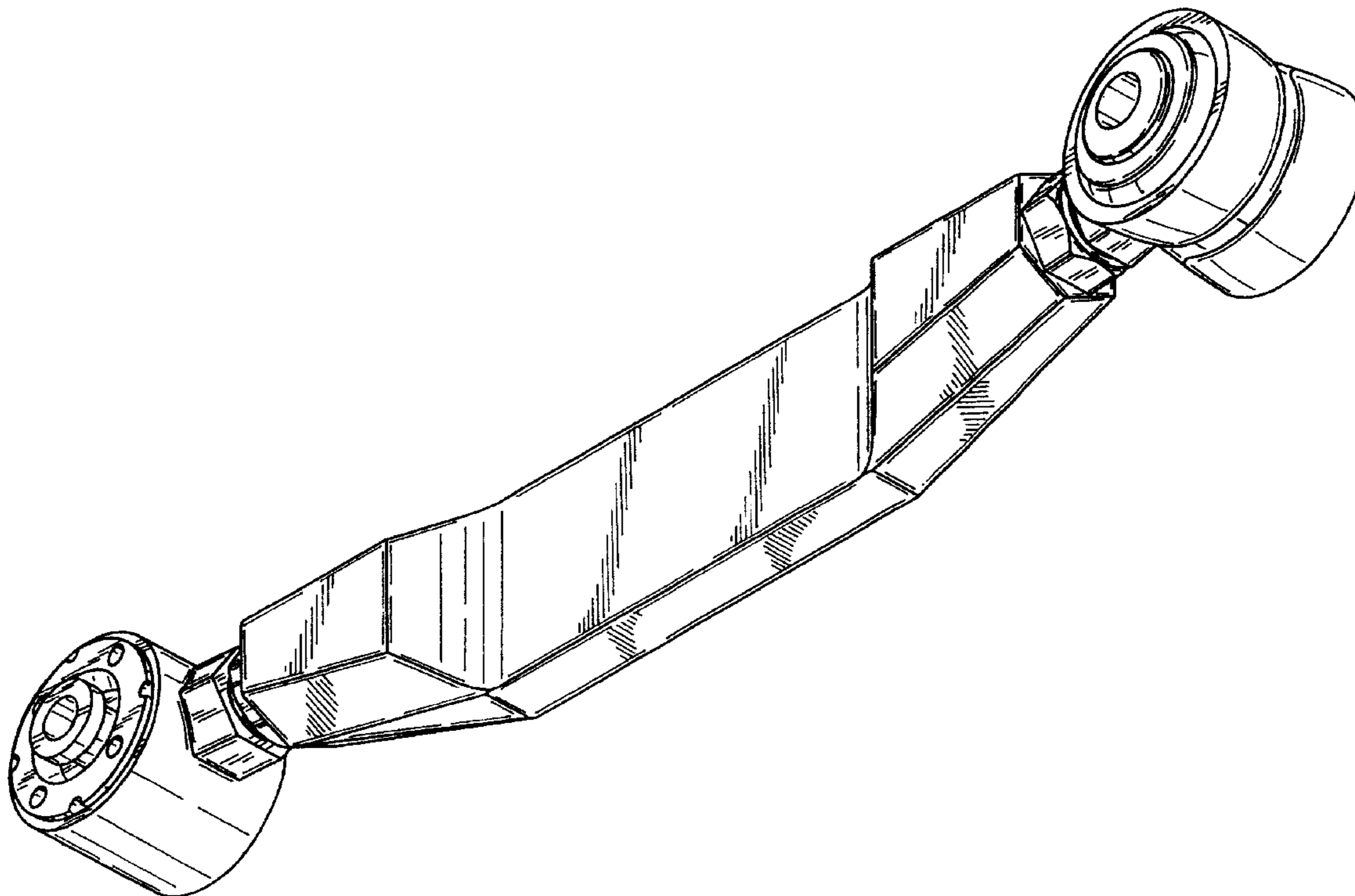

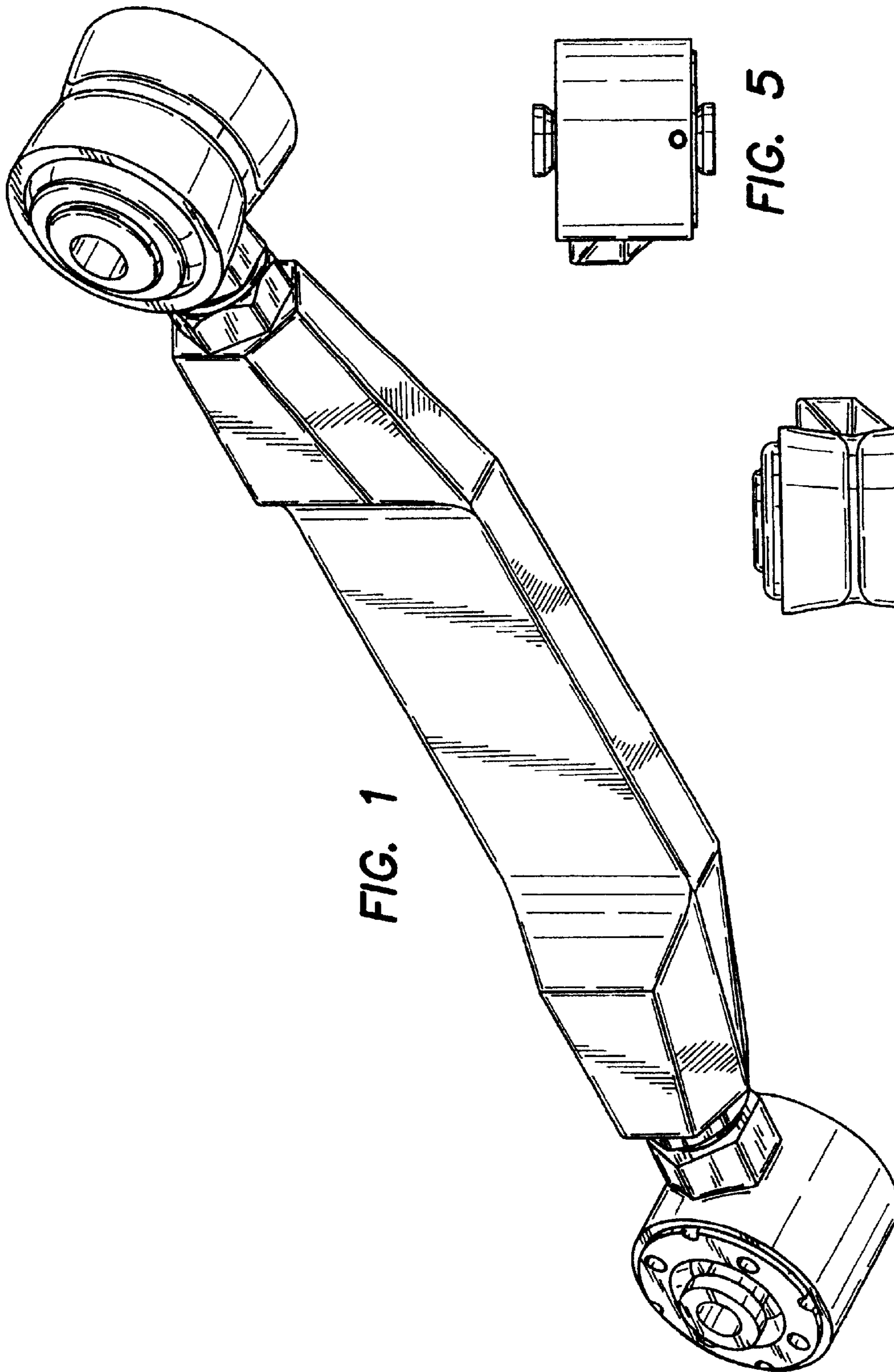

FIG. 1

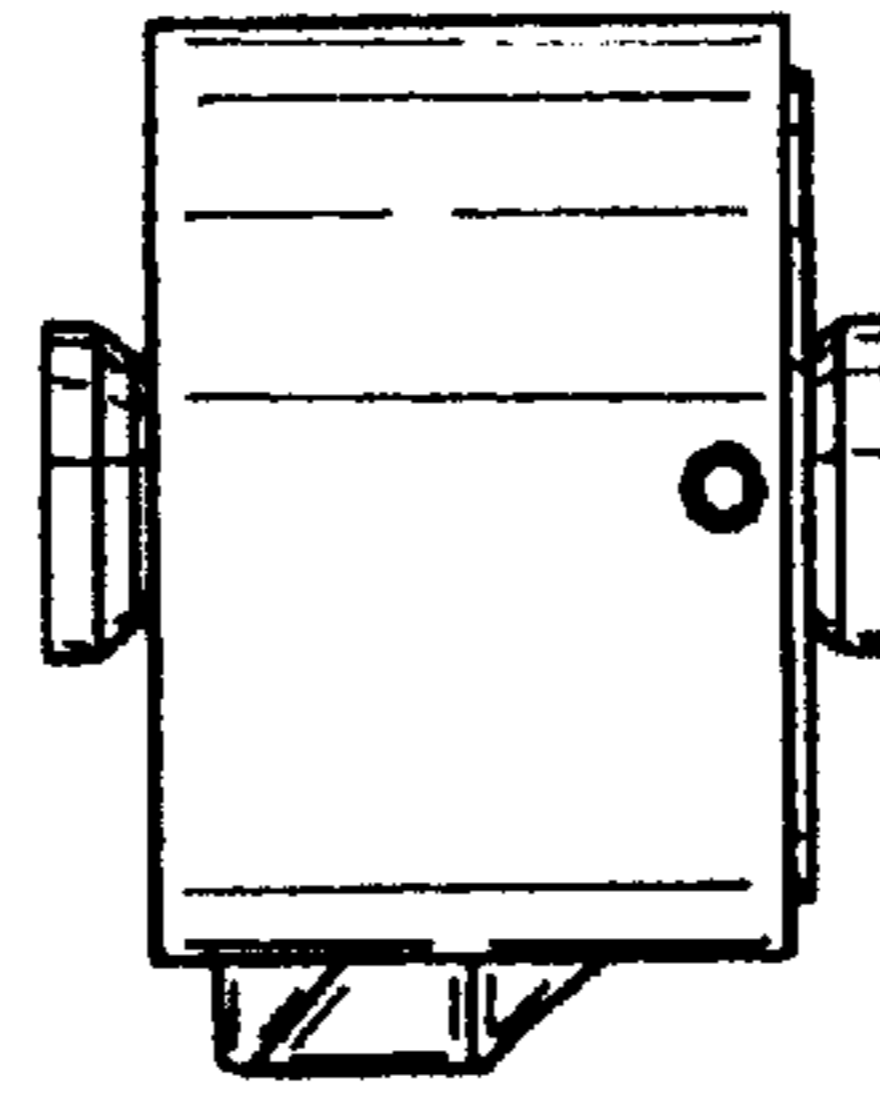

FIG. 5

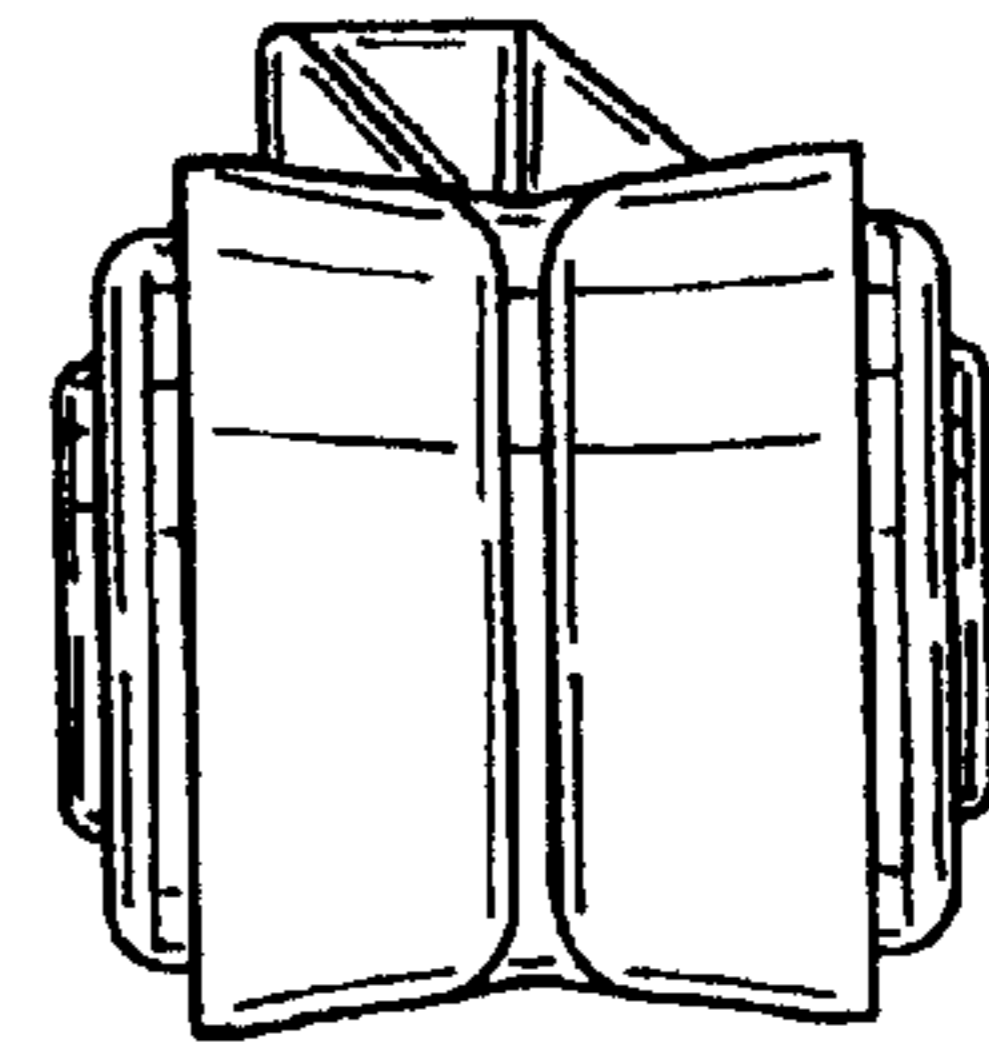

FIG. 4

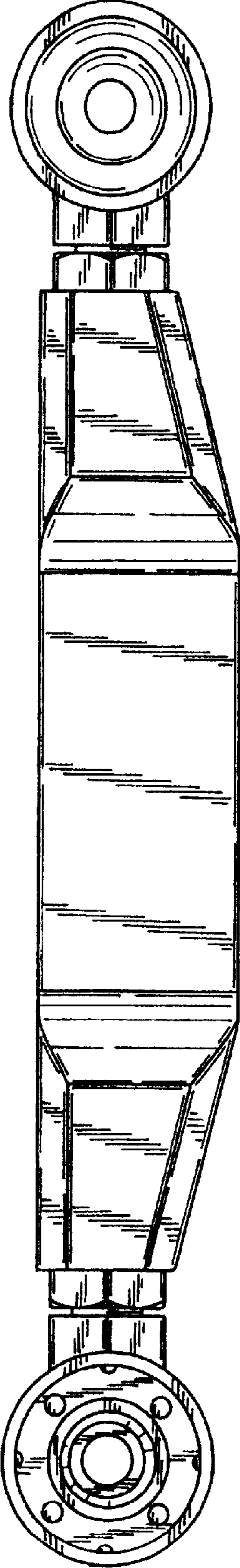

FIG. 2

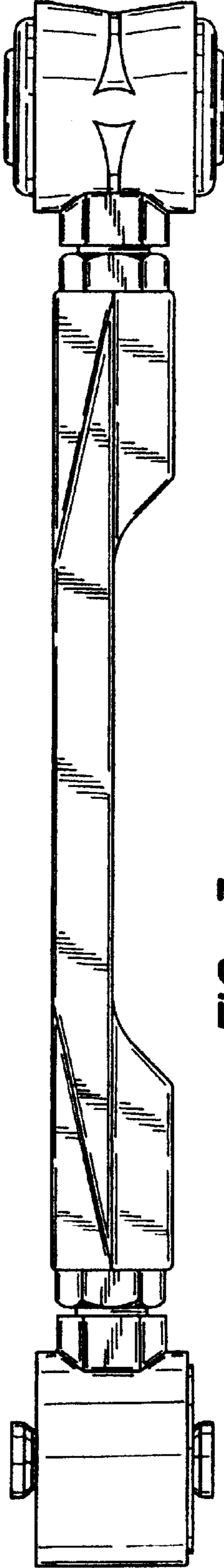
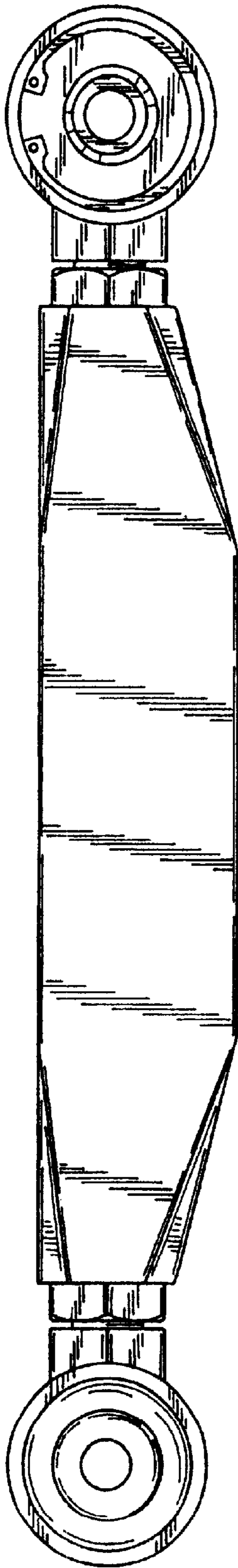
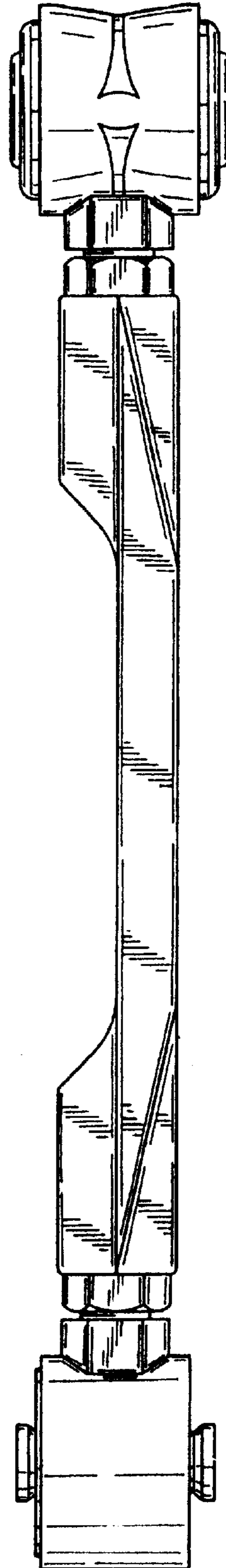

FIG. 3



**FIG. 6**



**FIG. 7**

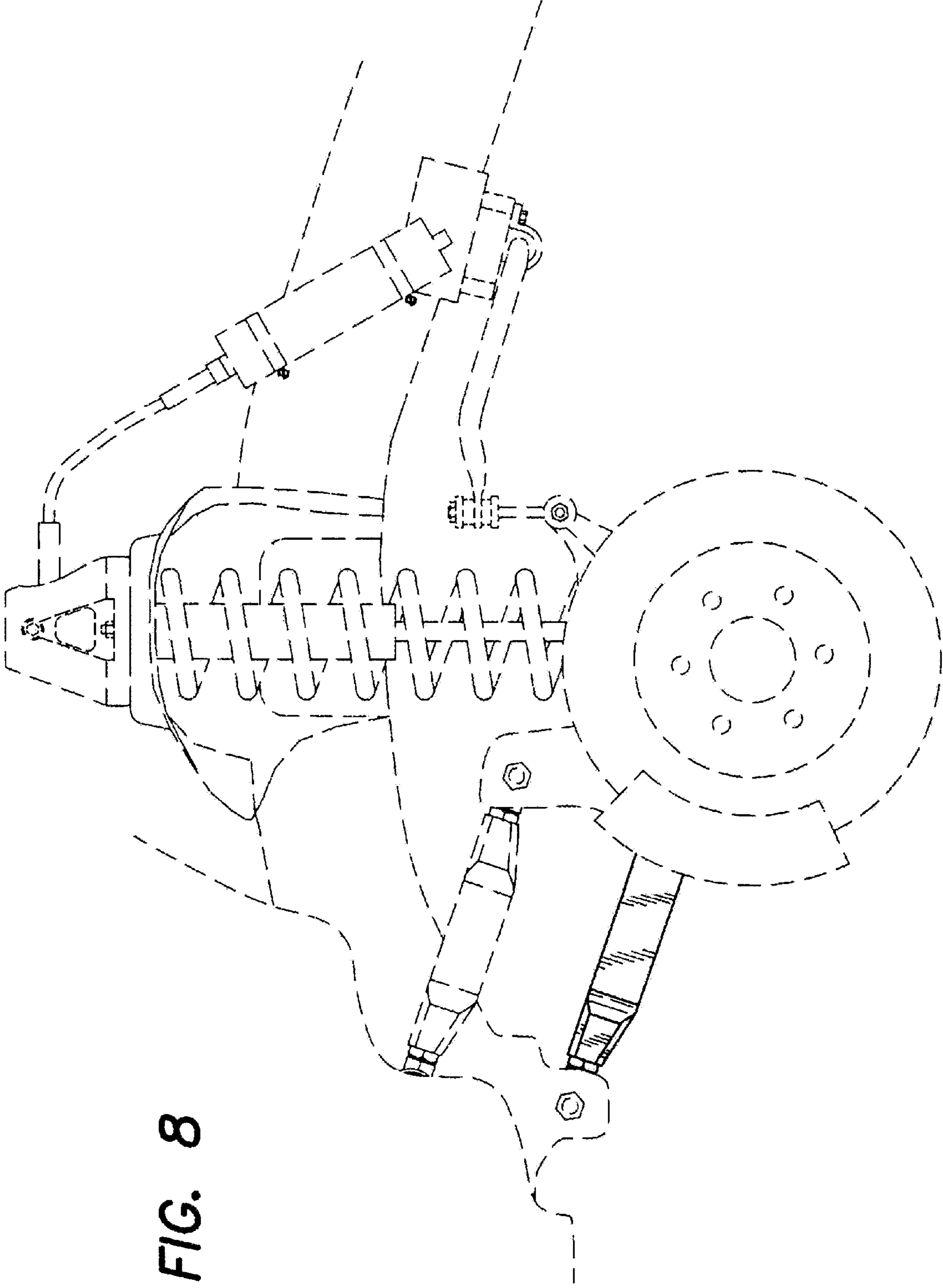
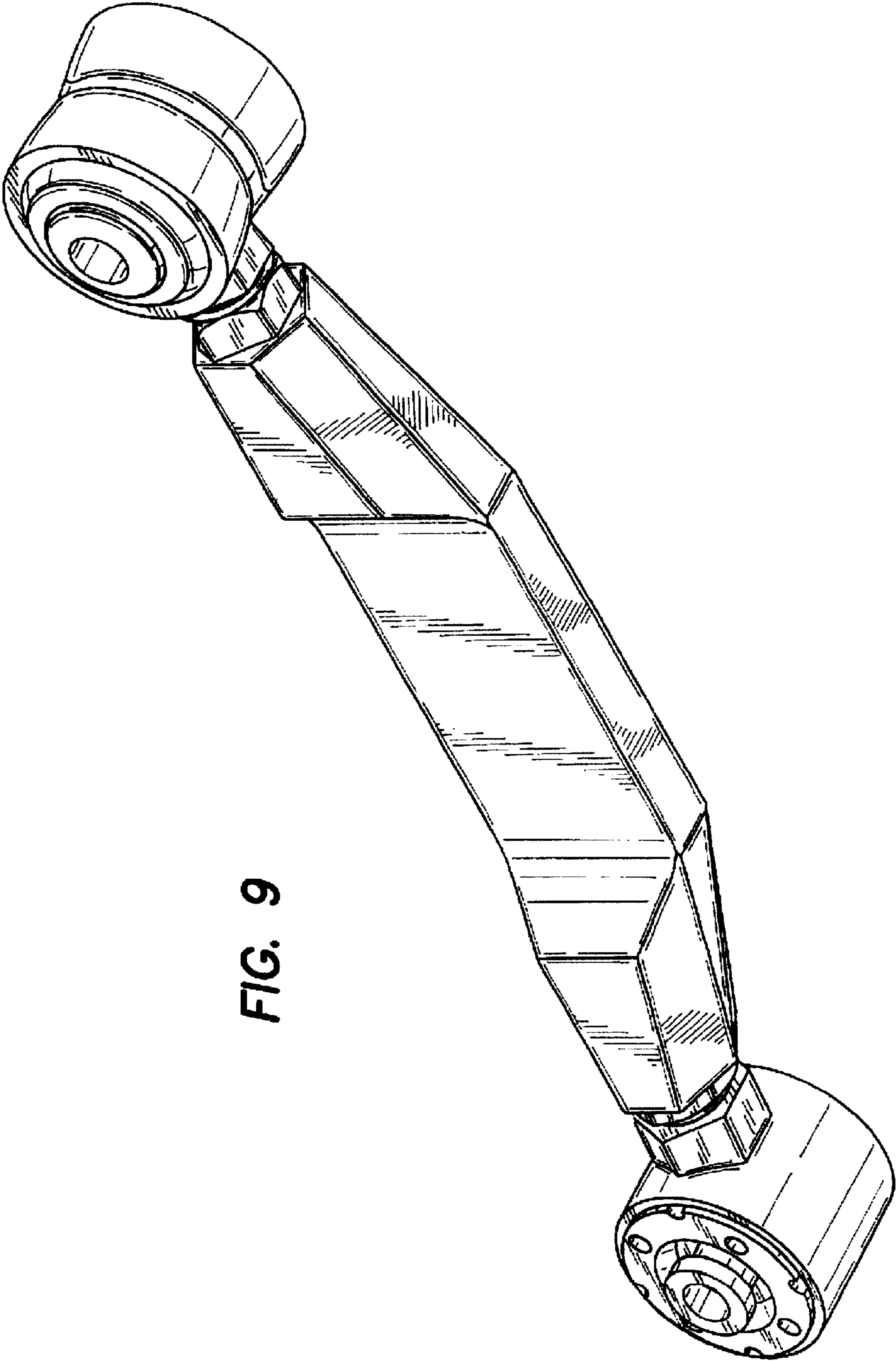

FIG. 8



**FIG. 9**

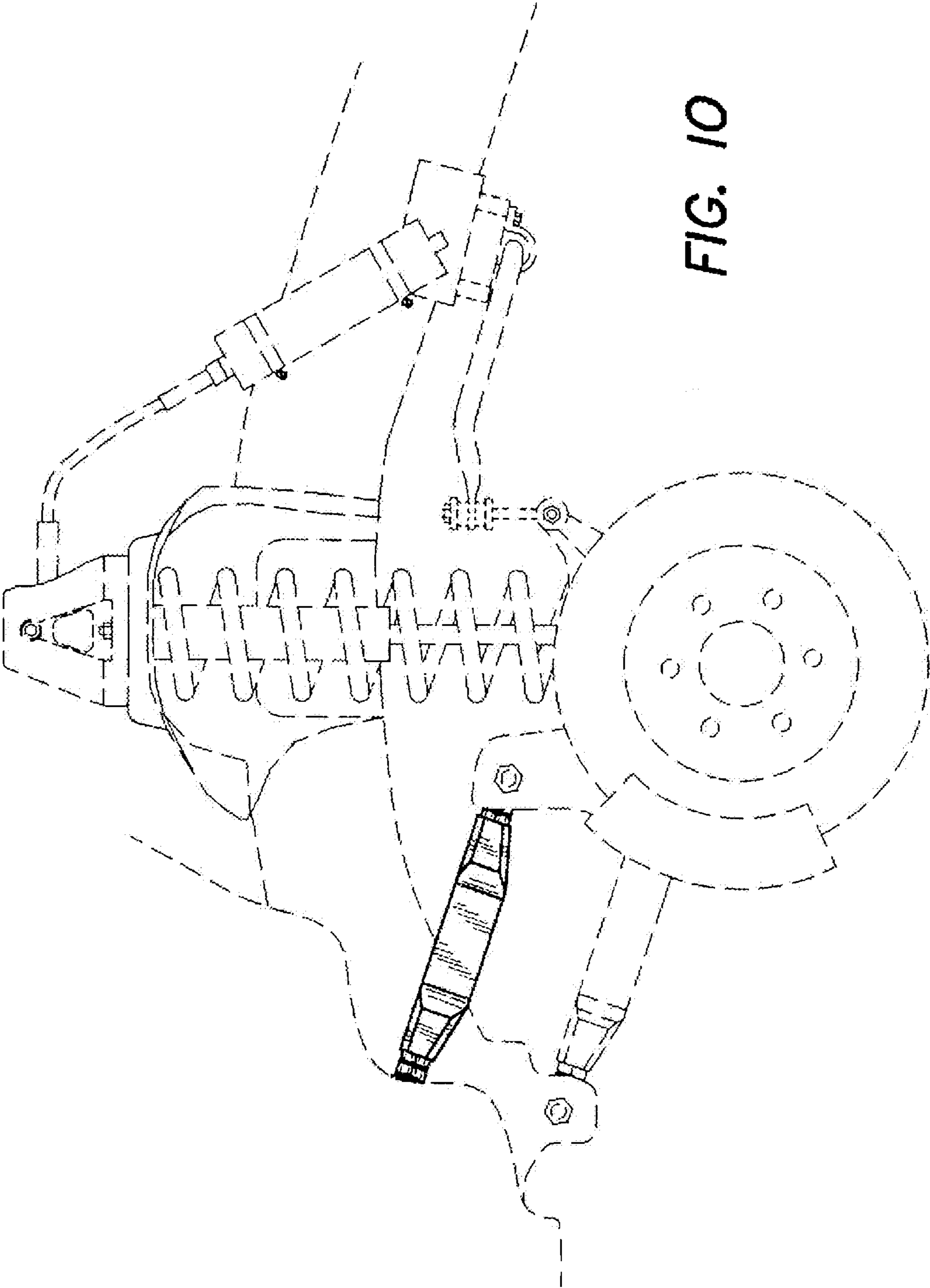

FIG. 10