

US00D544923S

(12) **United States Design Patent** (10) **Patent No.:** **US D544,923 S**
Brase et al. (45) **Date of Patent:** **** Jun. 19, 2007**

(54) **APPARATUS FOR A VIDEO GAME SYSTEM**
(75) Inventors: **Kevin Brase**, Corinth, TX (US);
Michael Hammond, Madison, WI (US)
(73) Assignee: **Radica Games, Ltd.**, Hamilton (BM)
(**) Term: **14 Years**
(21) Appl. No.: **29/247,711**
(22) Filed: **Jul. 5, 2006**

5,911,634 A 6/1999 Nidata et al.
6,033,014 A 3/2000 Nightengale
6,044,772 A 4/2000 Gaudette et al.
6,083,106 A 7/2000 McDowell
D446,263 S 8/2001 Heys
6,283,546 B1 9/2001 Hill
D471,594 S 3/2003 Nojo
6,568,334 B1 5/2003 Gaudette et al.
6,663,058 B1 12/2003 Peterson et al.
D493,843 S 8/2004 Jackson et al.
2003/0172290 A1 9/2003 Rice

Related U.S. Application Data

(62) Division of application No. 29/205,268, filed on May 12, 2004, now Pat. No. Des. 527,054.

(51) **LOC (8) Cl.** **21-01**
(52) **U.S. Cl.** **D21/326; D21/333**
(58) **Field of Classification Search** D21/324-328,
D21/333, 662, 686, 690, 695; 273/148 B,
273/148 A; 463/46, 47, 51, 29-35
See application file for complete search history.

References Cited

U.S. PATENT DOCUMENTS

2,269,444 A 1/1942 Durham et al.
D188,376 S 7/1960 Hotkins
4,418,911 A 12/1983 Bowers et al.
4,630,817 A * 12/1986 Buckley 463/37
4,711,447 A * 12/1987 Mansfield 463/37
5,054,771 A 10/1991 Mansfield et al.
5,195,746 A 3/1993 Boyd et al.
5,290,034 A 3/1994 Hineman
5,299,810 A 4/1994 Pierce et al.
5,437,453 A 8/1995 Hineman
D384,705 S 10/1997 Muraki et al.
5,713,794 A 2/1998 Shimojima et al.
D403,024 S * 12/1998 Muraki et al. D21/326
D407,759 S 4/1999 Isetani et al.

FOREIGN PATENT DOCUMENTS

JP 11-179051 7/1999

OTHER PUBLICATIONS

www.game-revolution.com/games/hardware/intensor.htm, printed on Jan. 6, 2004.

* cited by examiner

Primary Examiner—Prabhakar Deshmukh
(74) *Attorney, Agent, or Firm*—Bell, Boyd & Lloyd LLP

(57) **CLAIM**

The ornamental design for an apparatus for a video game system, as shown and described.

DESCRIPTION

FIG. 1 is a front perspective view of an apparatus for a video game system showing our new design;
FIG. 2 is a front elevational view thereof;
FIG. 3 is a top plan view thereof; and,
FIG. 4 is a right side elevational view thereof.
The broken lines are for illustrative purpose only and form no part of the claimed design.

1 Claim, 4 Drawing Sheets

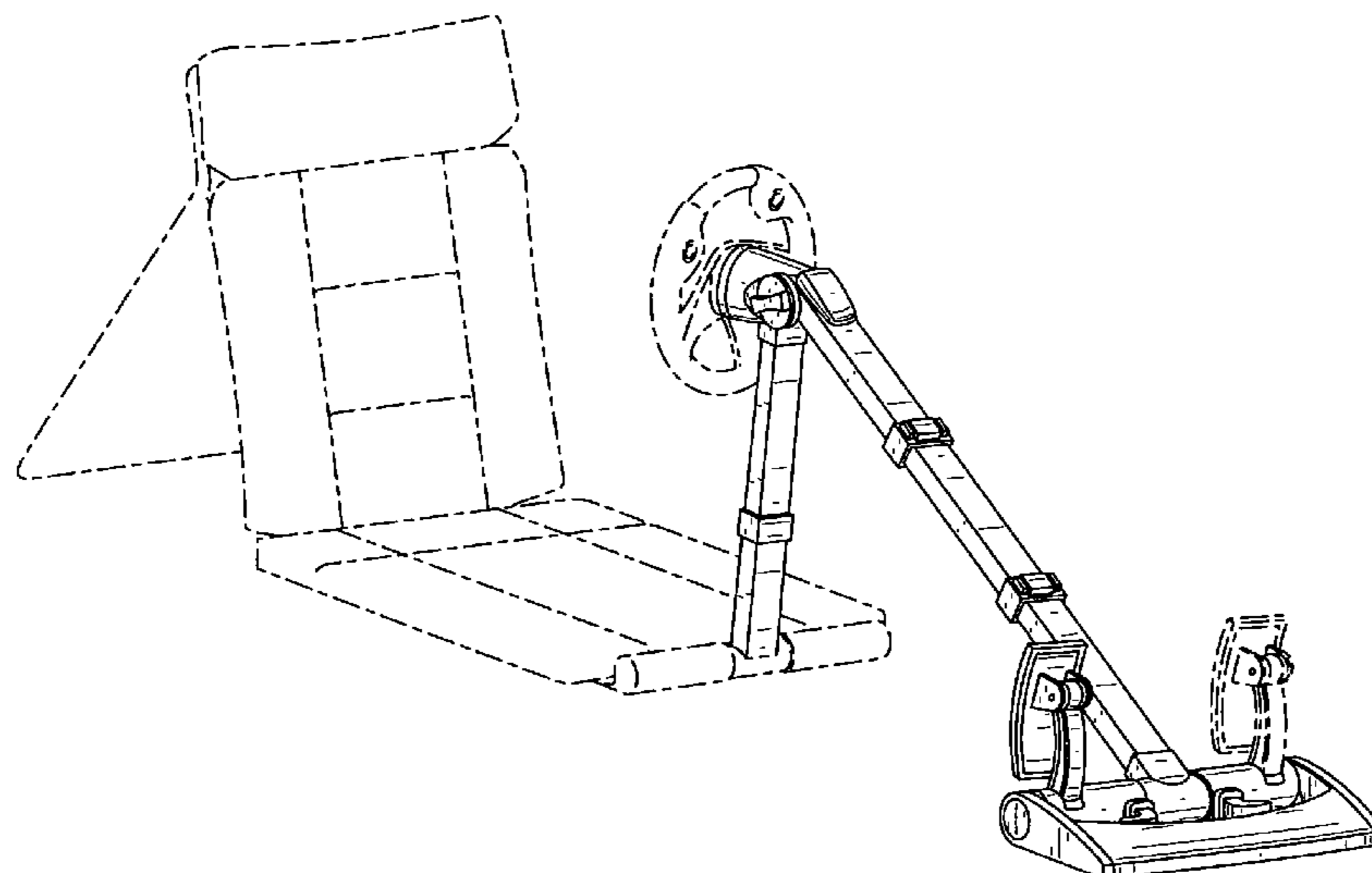

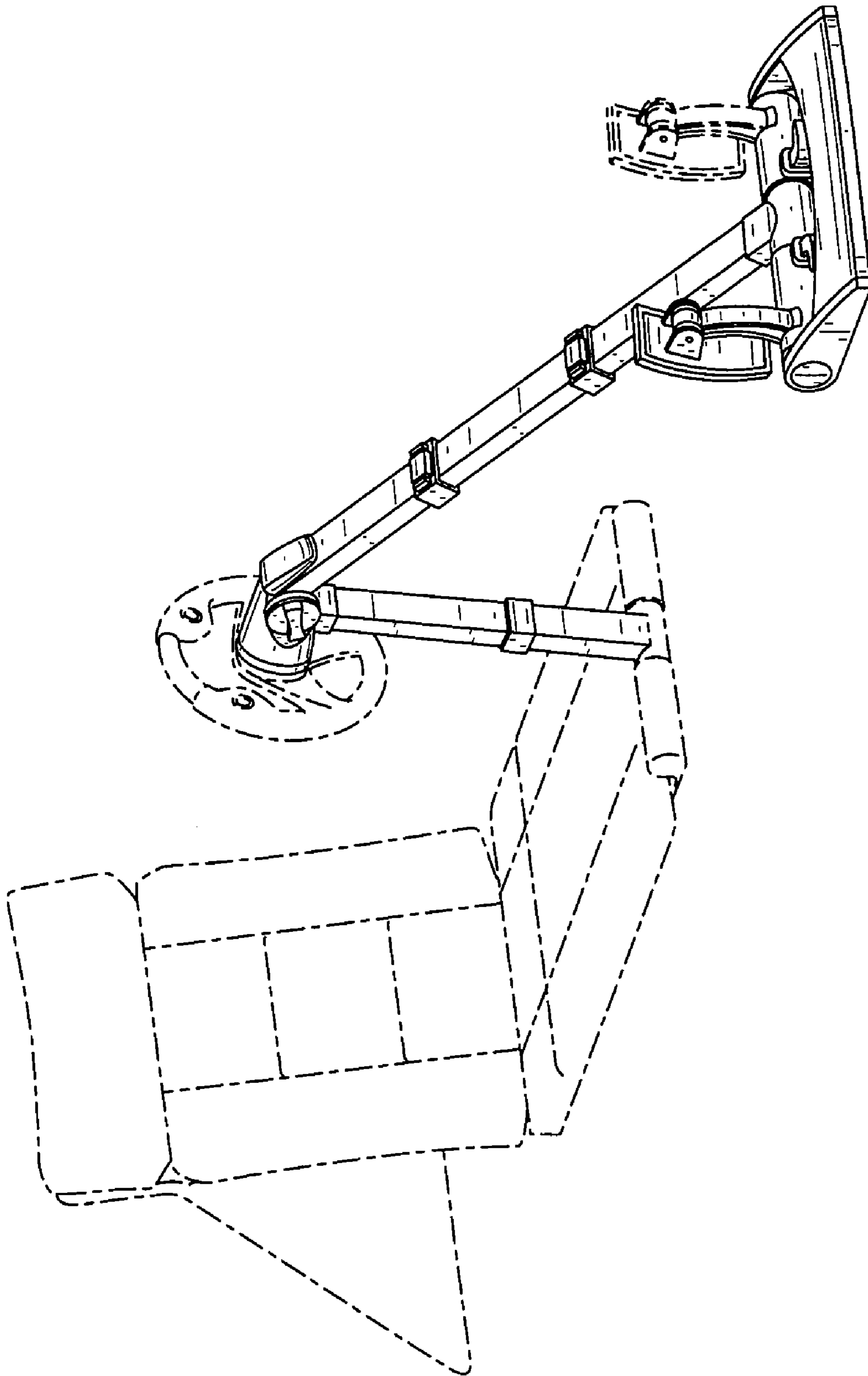

FIG. 1

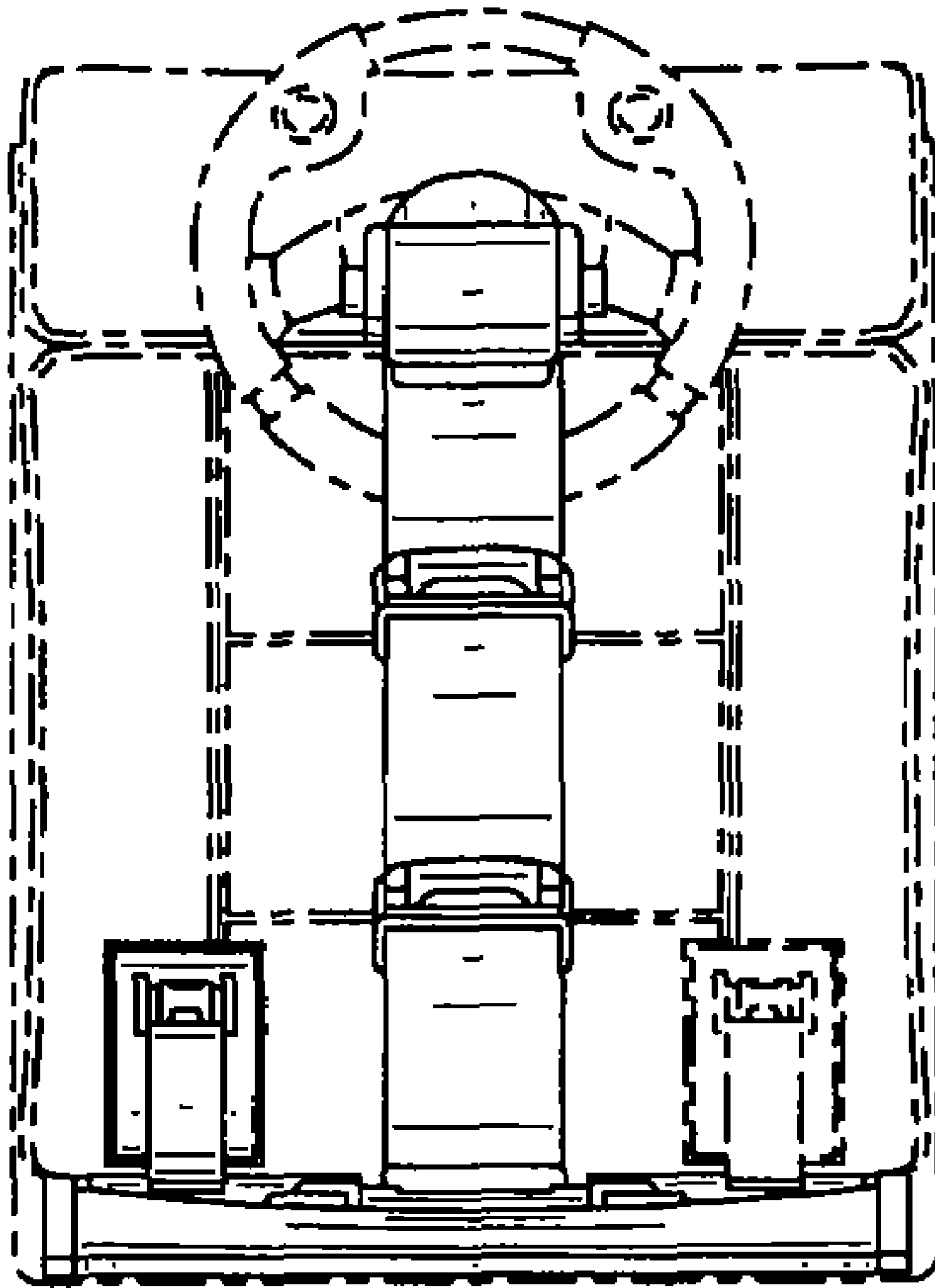

FIG. 2

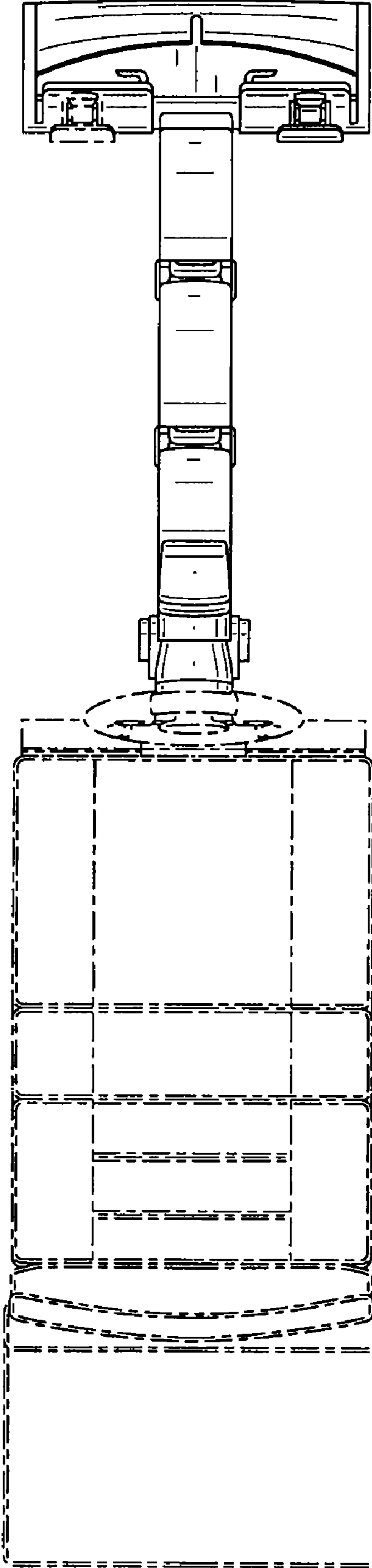

FIG. 3

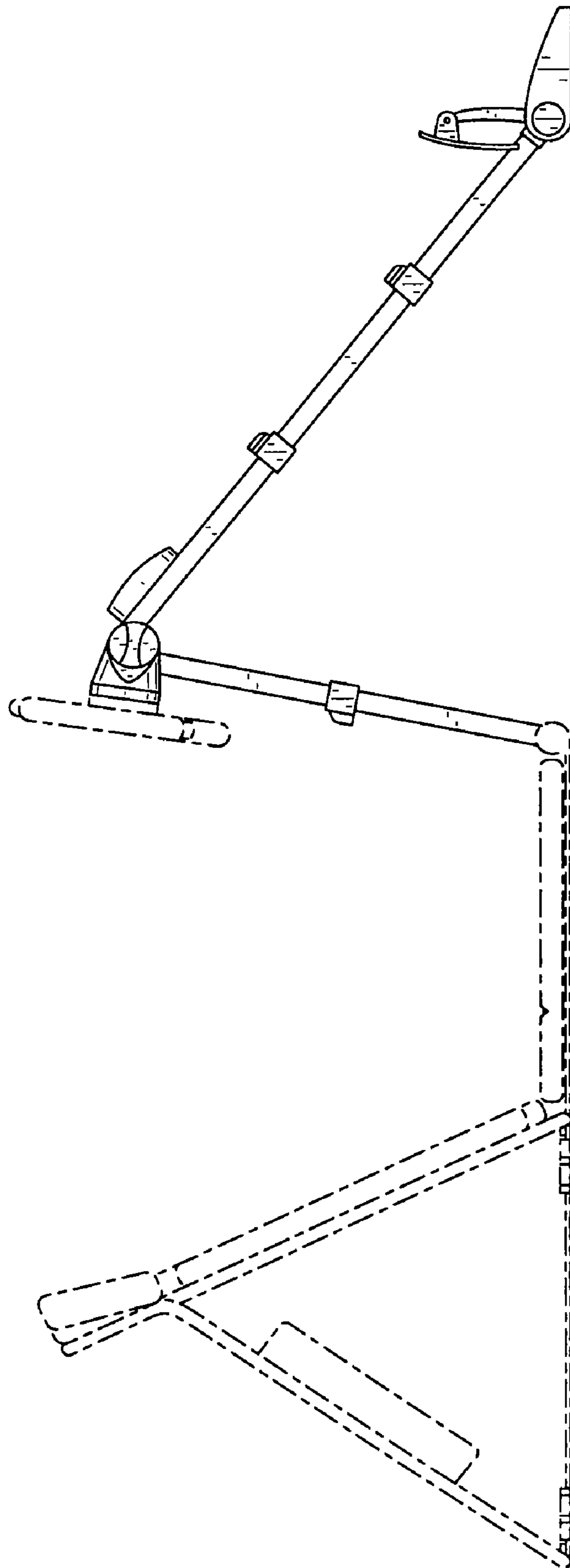

FIG. 4