



US00D544906S

(12) **United States Design Patent** (10) **Patent No.:** **US D544,906 S**  
**Alfonso et al.** (45) **Date of Patent:** **\*\* Jun. 19, 2007**

(54) **PRINTER HOUSING**

(75) Inventors: **Pedro M. Alfonso**, Austin, TX (US);  
**Kenneth Musgrave**, Austin, TX (US);  
**Thomas E. Pangburn**, Winchester, KY  
(US)

(73) Assignee: **Dell Products L.P.**, Round Rock, TX  
(US)

(\*\*) Term: **14 Years**

(21) Appl. No.: **29/230,490**

(22) Filed: **May 23, 2005**

(51) **LOC (8) Cl.** ..... **14-02**

(52) **U.S. Cl.** ..... **D18/55**

(58) **Field of Classification Search** ..... D18/36–39,  
D18/53–54, 54.1, 55; D14/420–425, 462–470;  
399/107; 400/613, 613.1–613.4, 691–694  
See application file for complete search history.

(56) **References Cited**

**U.S. PATENT DOCUMENTS**

D322,274 S *	12/1991	Tokuda et al. ....	D18/54
D343,414 S *	1/1994	Tokuda et al. ....	D18/55
D351,189 S *	10/1994	Yamaguchi et al. ....	D18/55
D368,113 S *	3/1996	Tanaka et al. ....	D18/55
D378,218 S *	2/1997	Hong et al. ....	D18/55
D378,300 S *	3/1997	Ito ....	D18/55
D391,288 S *	2/1998	Miyamoto ....	D18/55
D412,182 S *	7/1999	Miyazawa ....	D18/55
D412,341 S *	7/1999	Miyazawa ....	D18/55
D437,349 S *	2/2001	Saito et al. ....	D18/55

D439,276 S *	3/2001	Kemmochi et al. ....	D18/55
6,612,763 B1 *	9/2003	Yoshihara ....	400/692
D501,024 S *	1/2005	Suzuki et al. ....	D18/55
D501,874 S	2/2005	Ishigami ....	D18/50
D502,732 S	3/2005	Ishigami ....	D18/50
D505,154 S	5/2005	Wong et al. ....	D18/50
D521,060 S *	5/2006	Katayama ....	D18/55
D521,546 S *	5/2006	Katayama ....	D18/55
D523,071 S *	6/2006	Katayama et al. ....	D18/50

\* cited by examiner

*Primary Examiner*—Cathy Anne MacCormac

(74) *Attorney, Agent, or Firm*—Hamilton & Terrile, LLP;  
Robert W. Holland

(57) **CLAIM**

The ornamental design for a printer housing, as shown.

**DESCRIPTION**

FIG. 1 is a front perspective view of the printer housing comprising the present invention;

FIG. 2 is a front elevation view thereof;

FIG. 3 is a left side elevation view thereof;

FIG. 4 is a right side elevation view thereof;

FIG. 5 is a back view thereof;

FIG. 6 is a top view thereof; and,

FIG. 7 is a bottom view thereof.

The broken lines are for illustrative purposes only and form no part of the claimed design.

**1 Claim, 4 Drawing Sheets**

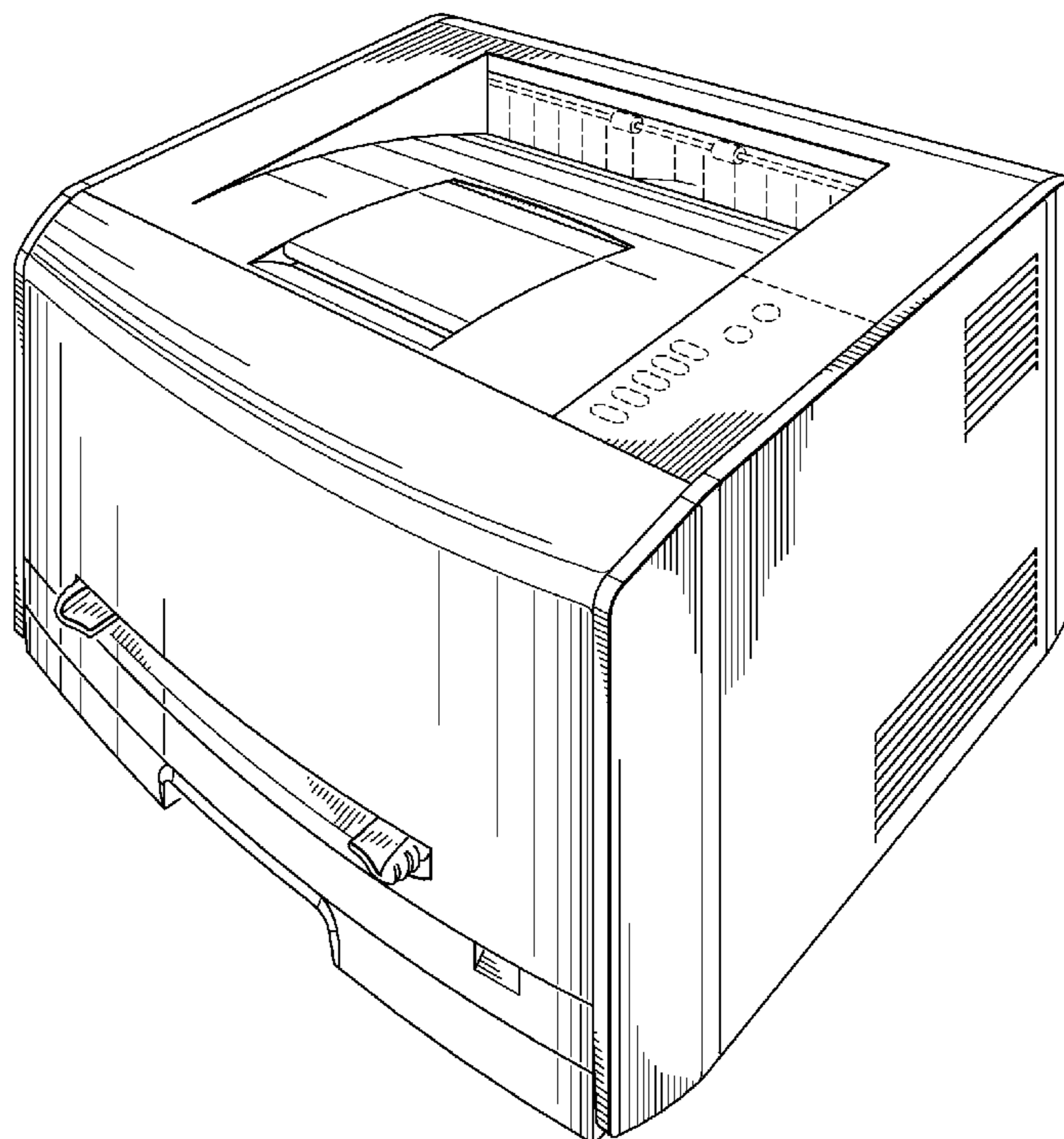

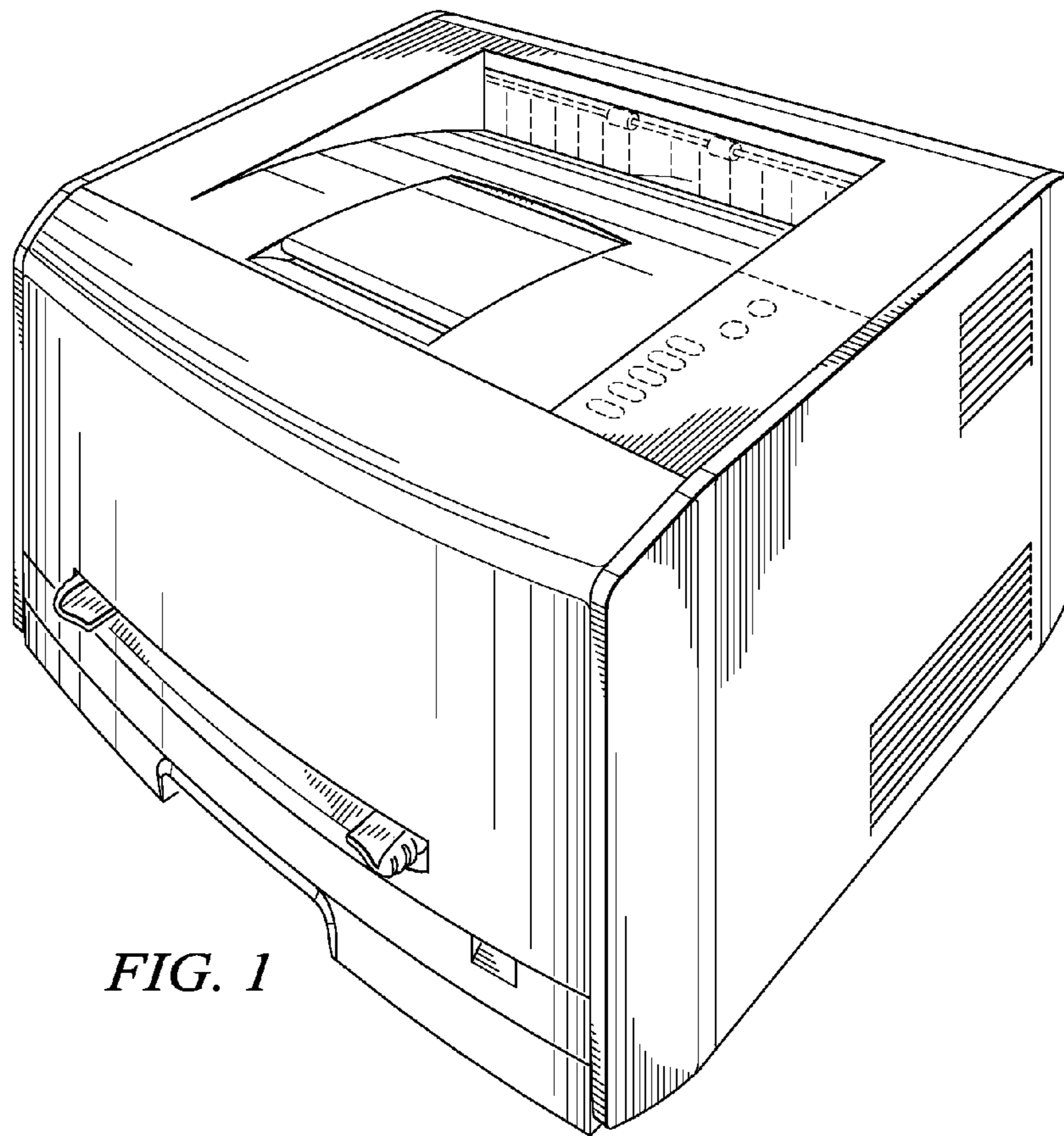

FIG. 1

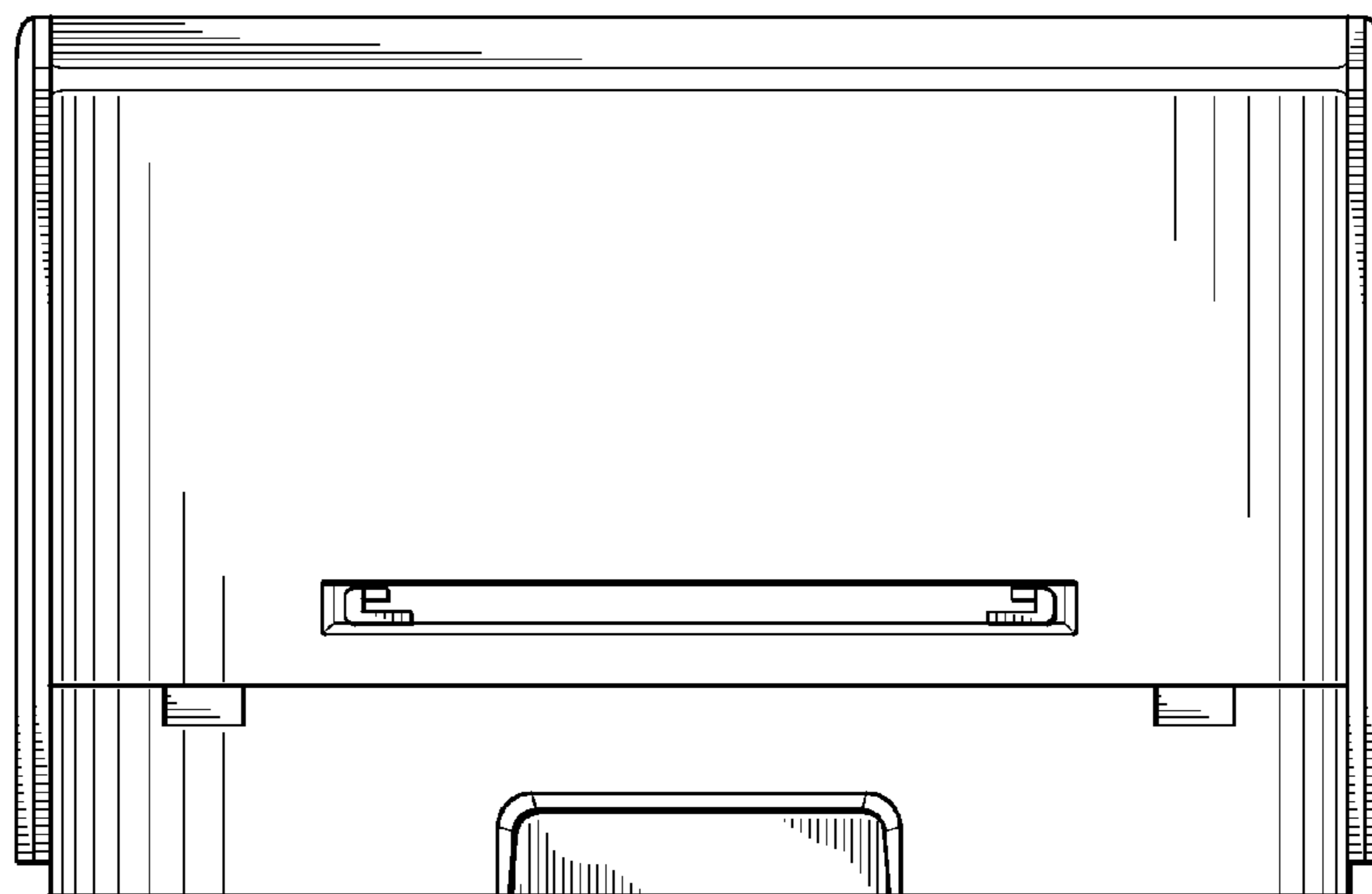
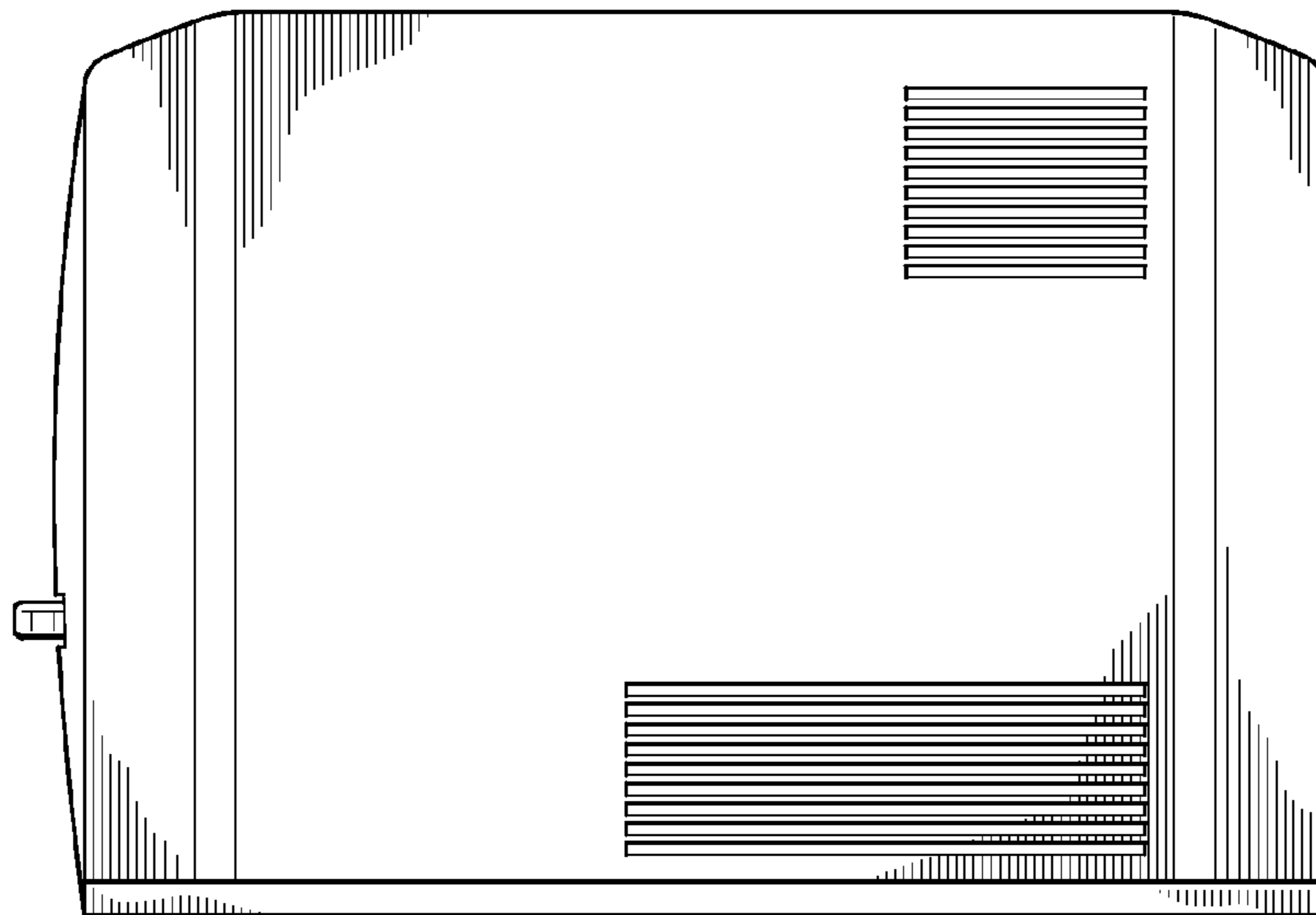
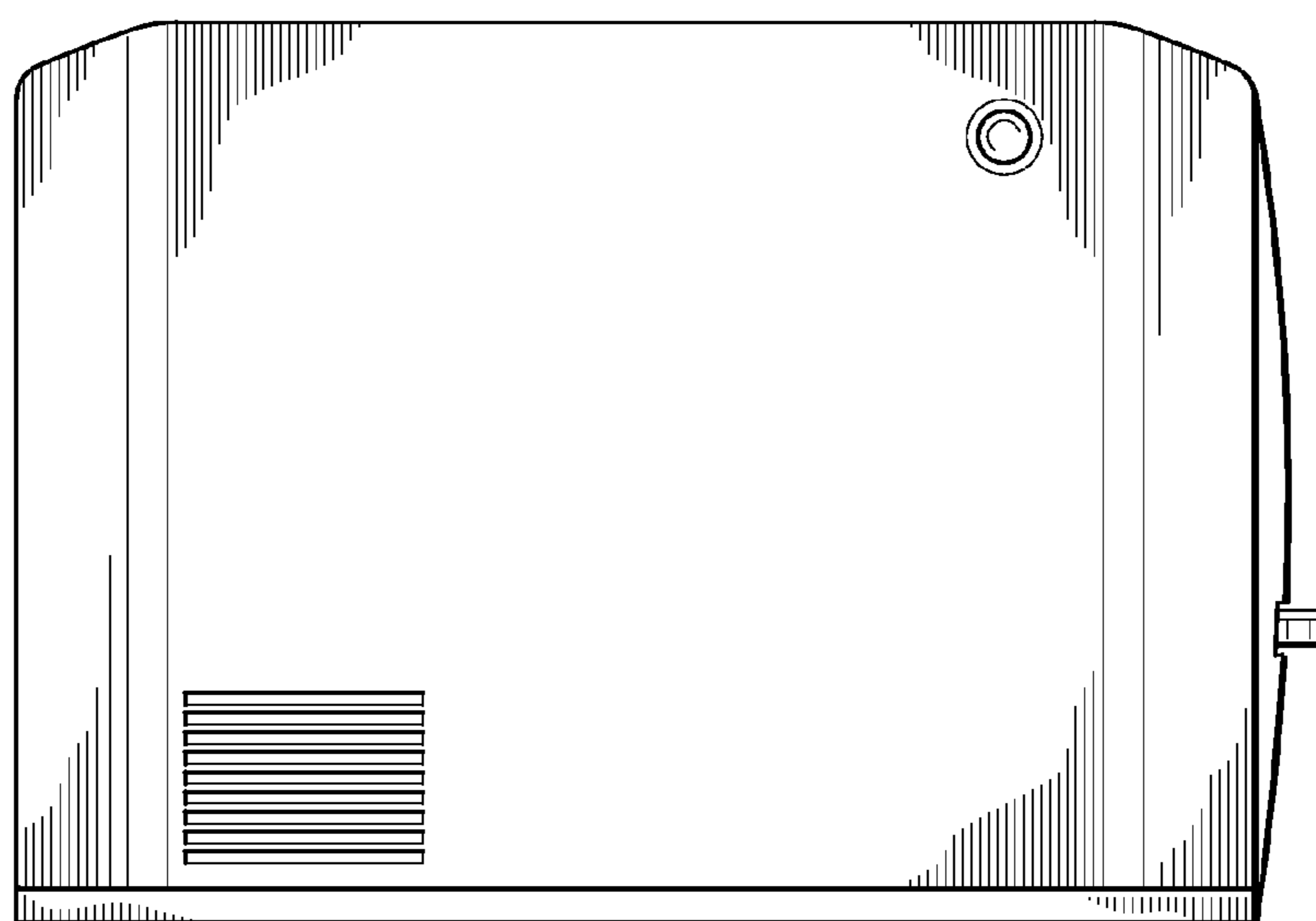

FIG. 2



*FIG. 3*



*FIG. 4*

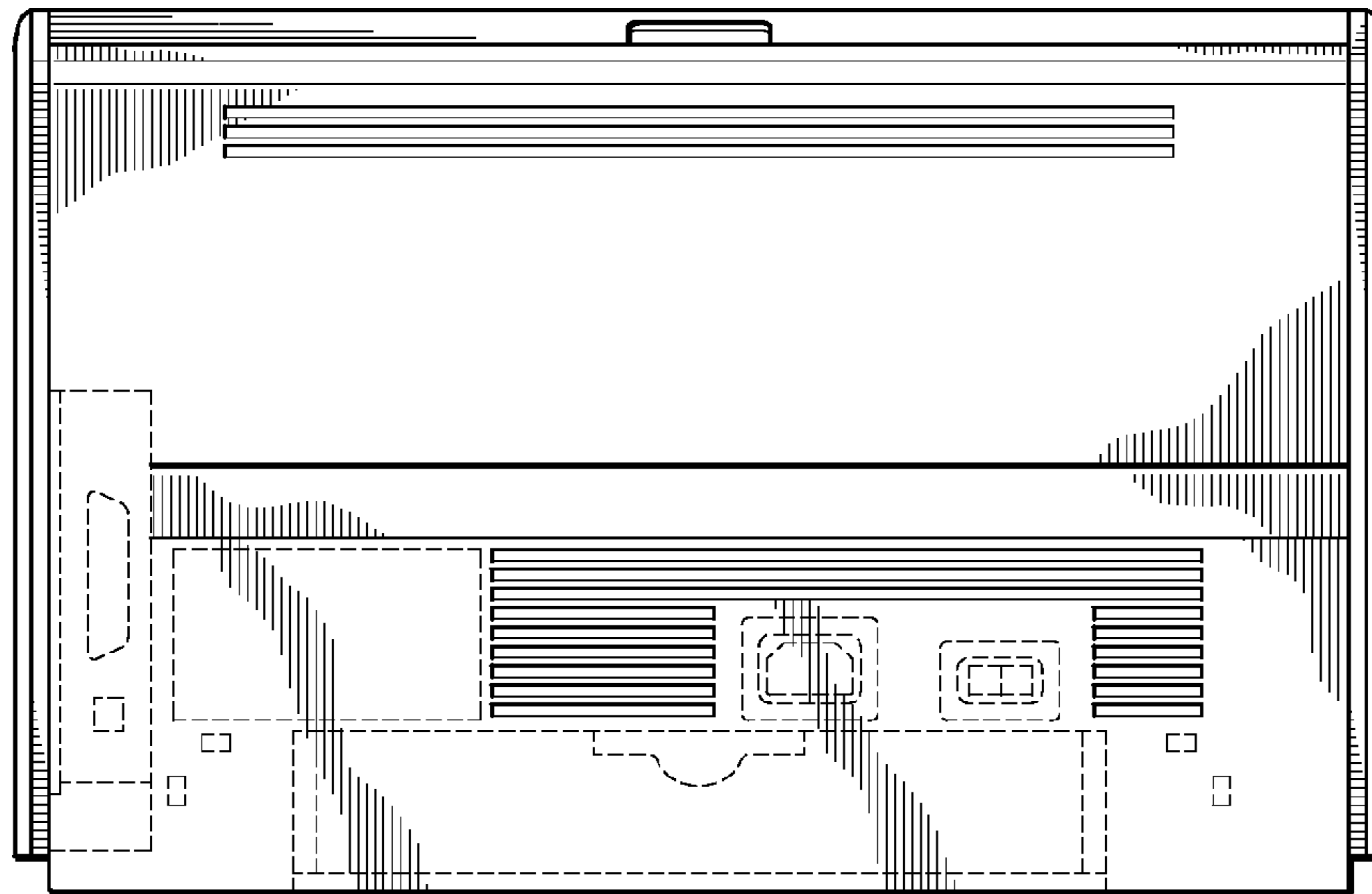

*FIG. 5*

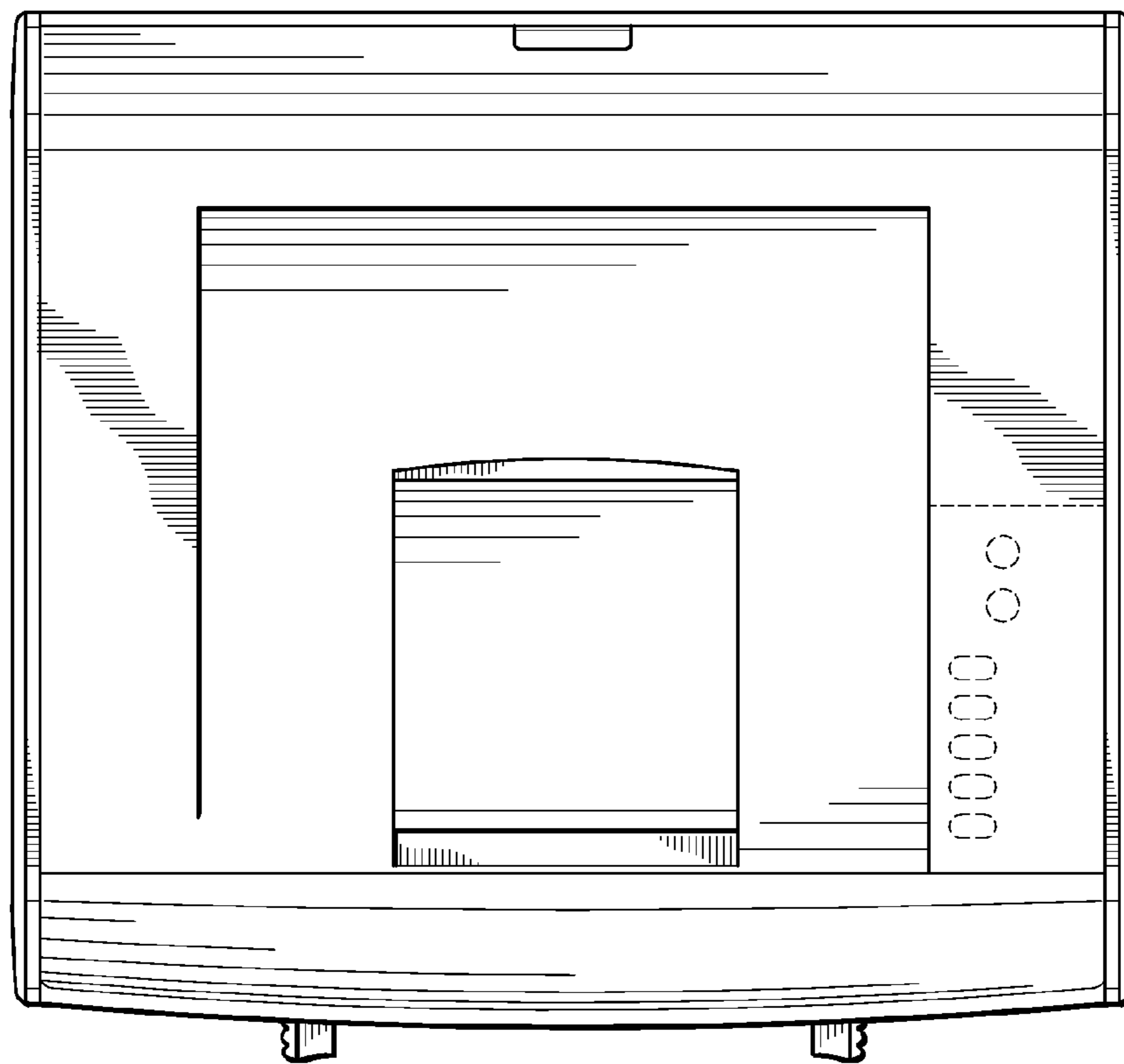

*FIG. 6*

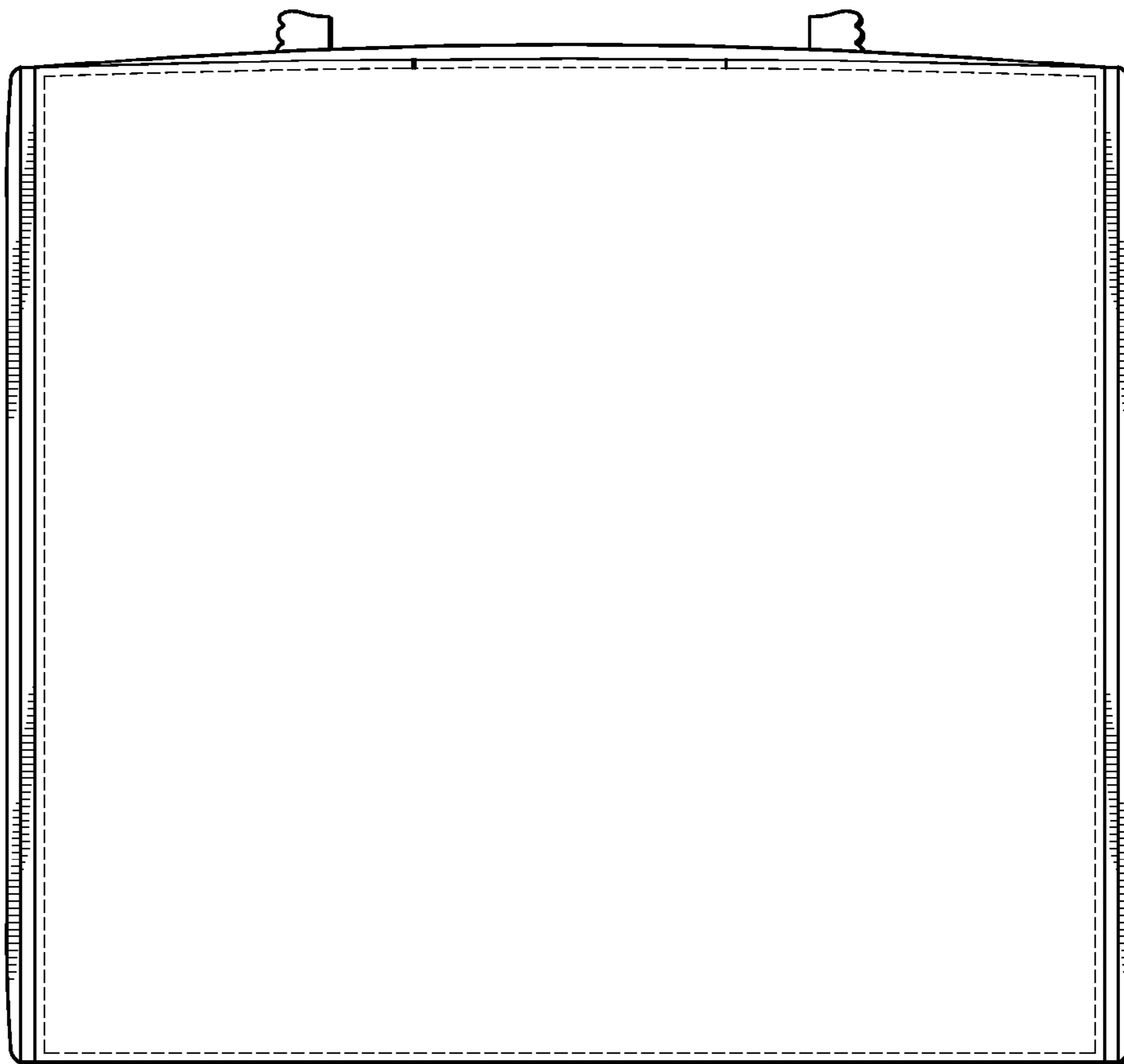

*FIG. 7*