



US00D544888S

(12) **United States Design Patent**
Mursch et al.

(10) **Patent No.:** **US D544,888 S**
(45) **Date of Patent:** **** Jun. 19, 2007**

(54) **FENDER**

(75) Inventors: **Michael E Mursch**, Scheyern (DE);
Alan A Davidovich, Garner, NC (US)

(73) Assignee: **Caterpillar Inc.**, Peoria, IL (US)

(**) Term: **14 Years**

(21) Appl. No.: **29/214,175**

(22) Filed: **Sep. 29, 2004**

(51) **LOC (8) Cl.** **15-03**

(52) **U.S. Cl.** **D15/28**

(58) **Field of Classification Search** D15/10,
D15/22-26, 28, 30, 33; D12/184; 180/89.1,
180/900, 89.12, 84; 56/DIG. 24

See application file for complete search history.

(56) **References Cited**

U.S. PATENT DOCUMENTS

D355,423 S * 2/1995 Woods et al. D15/23
D439,586 S * 3/2001 Moehle et al. D15/33
D440,234 S * 4/2001 Kato et al. D15/23

OTHER PUBLICATIONS

New Holland Construction Loader Backhoes Brochure, published 2003, www.newhollandconstruction.com.
Caterpillar TH330B Telehandler, published 2003, [online], [retrieved on Jun. 30, 2004] Retrieved from the Machine/Products Database of the Caterpillar website using Internet <URL: <http://www.cat.com/> >.
Hydrema 928C Articulated Combination Machine, [online], (retrieved on Jun. 30, 2004) Retrieved from the Hydrema website using Internet <URL:<http://www.xtest.dk.hydrema/>>.

Caterpillar 902 Wheel Loader, published 2001, [online], [retrieved on Jun. 06, 2004] Retrieved from the Machines/Products Database of the Caterpillar website using Internet <URL: <http://www.cat.com/>>.

Hydrema News 12, Dec. 2002, [online], [retrieved on Oct. 5, 2005] Retrieved from the Hydrema website using internet <URL: <http://www.hydrema.com/>>.

Photograph of Caterpillar 420D Backhoe Loader, Sep. 4, 2004.

* cited by examiner

Primary Examiner—Stella Reid
Assistant Examiner—Mark A. Goodwin

(74) *Attorney, Agent, or Firm*—D. James Barnes

(57) **CLAIM**

The ornamental design for a fender, as substantially shown and described.

DESCRIPTION

FIG. 1 is a perspective view of a fender showing our new design;

FIG. 2 is a front view thereof;

FIG. 3 is a top view thereof;

FIG. 4 is a right side view thereof; and,

FIG. 5 is a left side view thereof.

The right side fender is a mirror image of the design shown in FIGS. 1-5.

The broken lines showing various features are for illustrative, environmental purposes only and form no part of the claimed design.

1 Claim, 5 Drawing Sheets

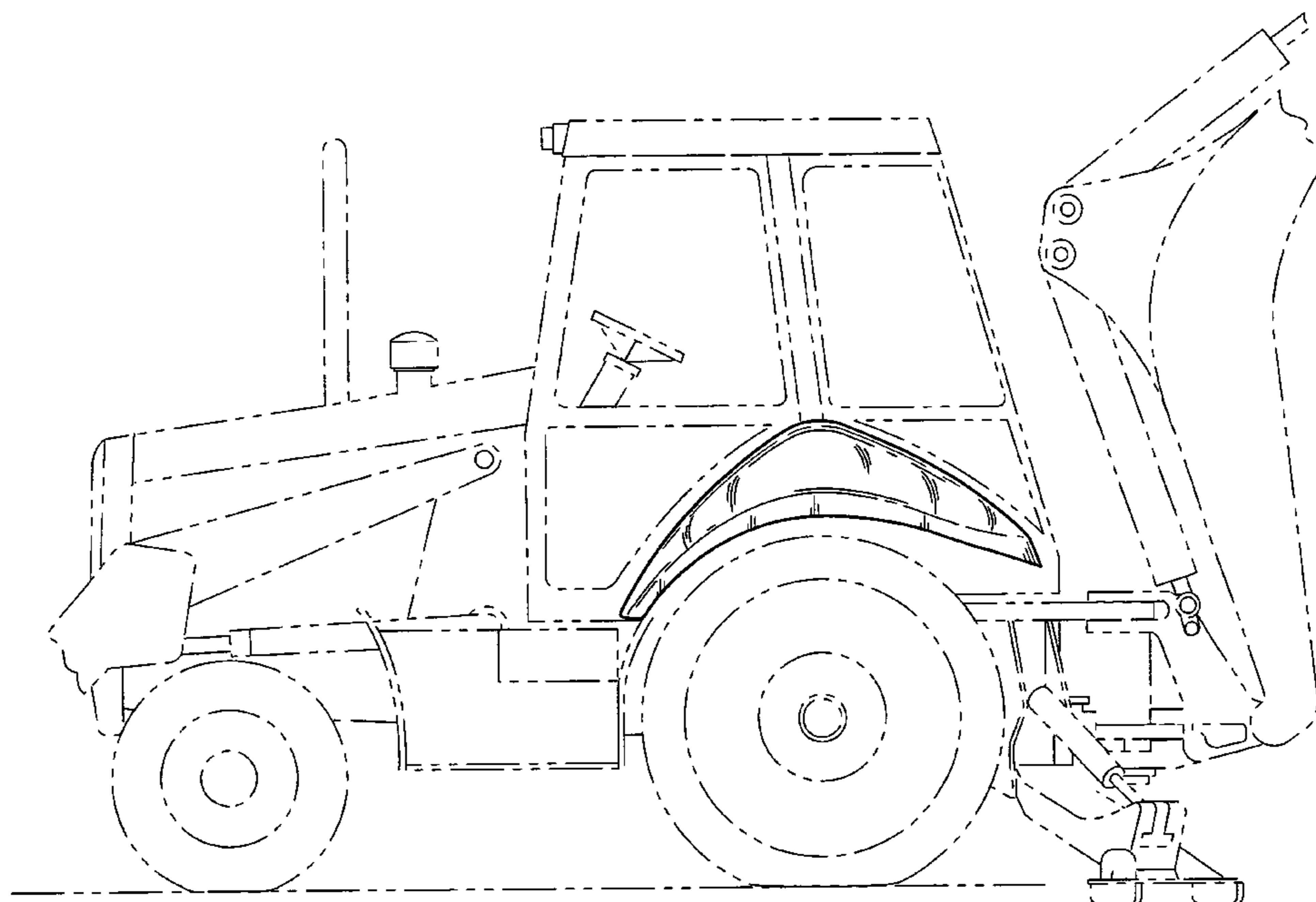
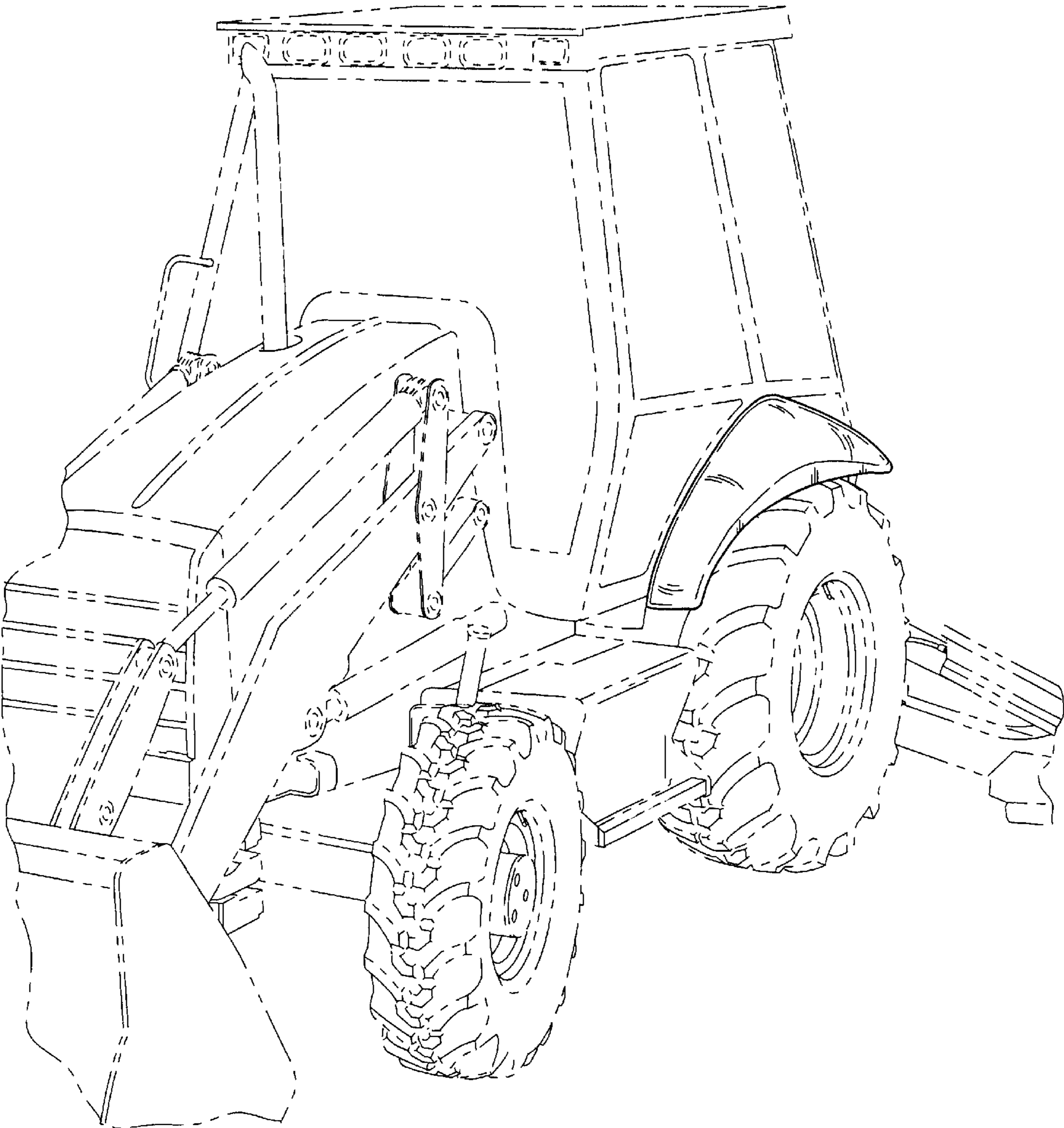
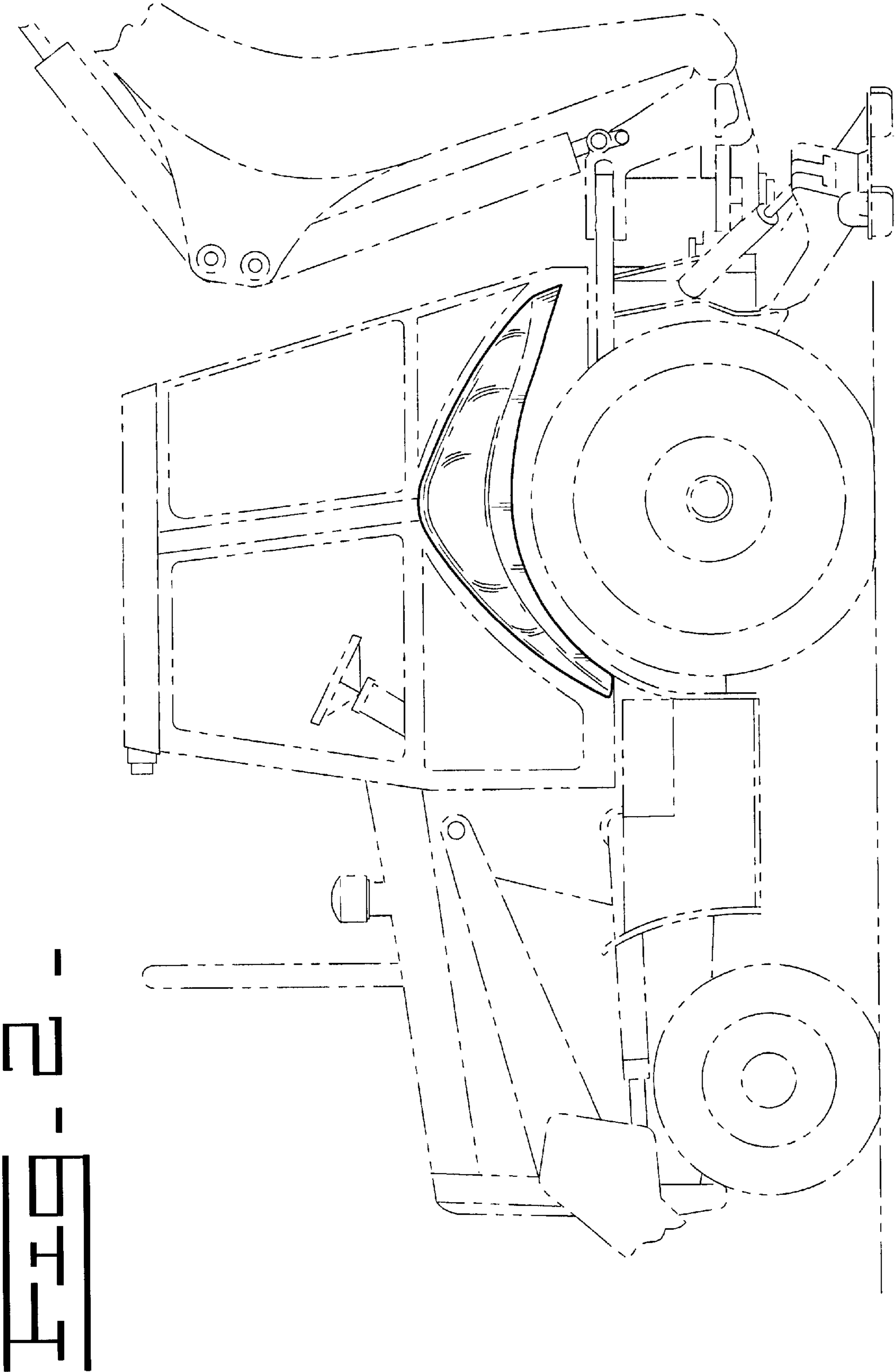

FIG. 1.





M -
THE

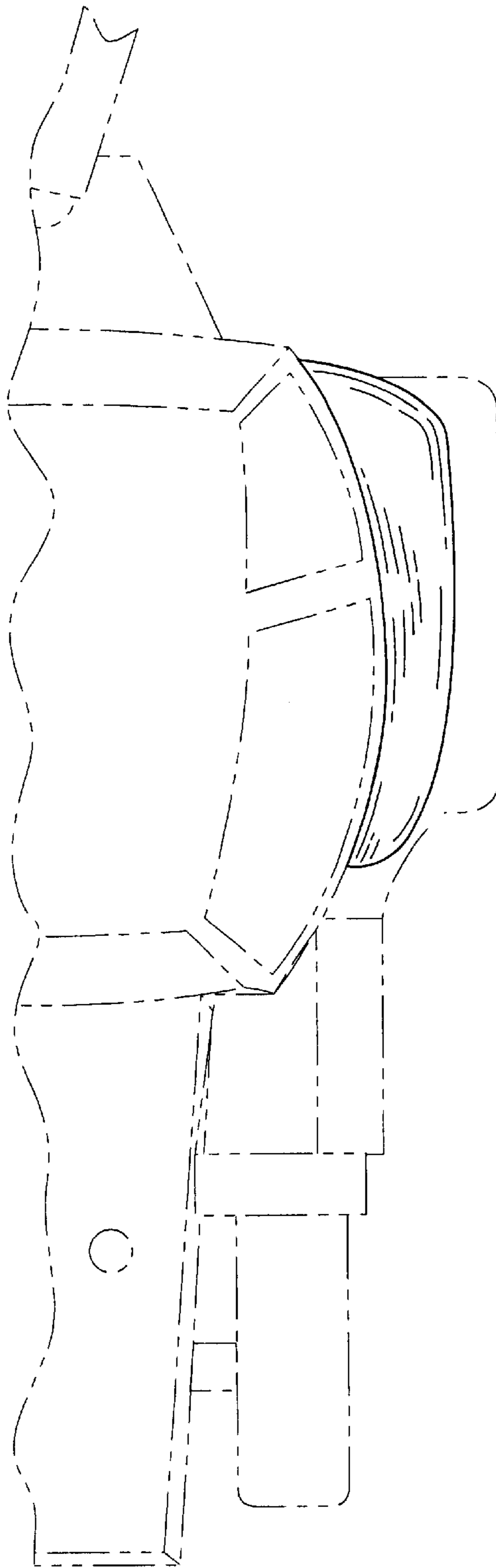

FIG. 4 - -

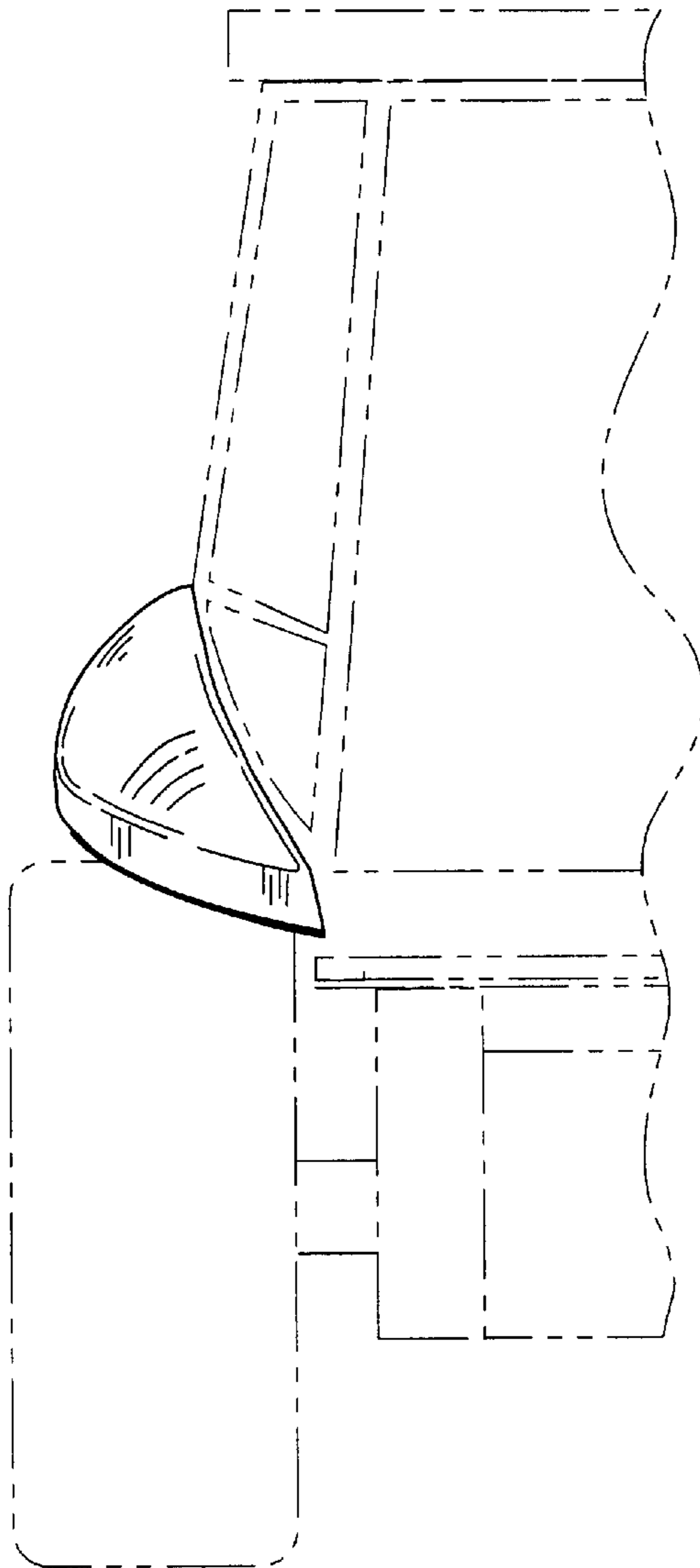

FIG. 5

