

US00D544816S

(12) **United States Design Patent** (10) **Patent No.:** **US D544,816 S**
Davidson et al. (45) **Date of Patent:** **** Jun. 19, 2007**

(54) **MOTORCYCLE**

(75) Inventors: **Willie G. Davidson**, Delafield, WI (US); **Frank Savage**, West Bend, WI (US); **Louis Netz**, Grafton, WI (US); **Alan P. Flanders**, Adell, WI (US); **Steven F. Clements**, Wind Lake, WI (US); **Richard J. Christoph**, Wauwatosa, WI (US); **Mark Daniels**, Mequon, WI (US); **John F. Wolanski**, Menomonee Falls, WI (US); **Joshua J. Hedtke**, Brookfield, WI (US); **Dominic Keogh**, Germantown, WI (US); **William E. Crowe**, Wauwatosa, WI (US); **Jeffrey A. Kohler**, Richfield, WI (US); **Douglas D. Reichardt**, West Bend, WI (US); **Richard P. Brault**, Cedarburg, WI (US); **Charles J. Lamb**, Greendale, WI (US); **Gregory R. Schmidt**, Port Washington, WI (US); **Everett H. Paddock**, Hartland, WI (US); **Nicholas J. LeRoy**, Big Bend, WI (US); **Daniel M. Sepic**, Mukwonago, WI (US)

(73) Assignee: **Harley-Davidson Motor Company Group, Inc.**, Milwaukee, WI (US)

(**) Term: **14 Years**

(21) Appl. No.: **29/248,514**

(22) Filed: **Aug. 18, 2006**

(51) **LOC (8) Cl.** **12-11**

(52) **U.S. Cl.** **D12/110**

(58) **Field of Classification Search** D12/110;
180/219

See application file for complete search history.

(56) **References Cited**

OTHER PUBLICATIONS

Harley-Davidson, Inc., "2003 Harley-Davidson® Motorcycles," pp. 10-15, published prior to Aug. 18, 2005.
Harley-Davidson, Inc., "2004 Harley-Davidson® Motorcycles," pp. 6-9, published prior to Aug. 18, 2005.
Harley-Davidson, Inc., "2006 Harley-Davidson® Motorcycles, The little handbook of living large," pp. 21-27, published prior to Aug. 18, 2005.

Primary Examiner—Alan P. Douglas

Assistant Examiner—Linda Brooks

(74) *Attorney, Agent, or Firm*—Michael Best & Friedrich LLP

(57) **CLAIM**

We claim the ornamental design for a motorcycle, as shown and described.

DESCRIPTION

FIG. 1 is a perspective view of a motorcycle;
FIG. 2 is a left side view of the motorcycle of FIG. 1;
FIG. 3 is a right side view of the motorcycle of FIG. 1;
FIG. 4 is a front view of the motorcycle of FIG. 1;
FIG. 5 is a rear view of the motorcycle of FIG. 1;
FIG. 6 is a top view of the motorcycle of FIG. 1; and,
FIG. 7 is a bottom view of the motorcycle of FIG. 1.

1 Claim, 7 Drawing Sheets

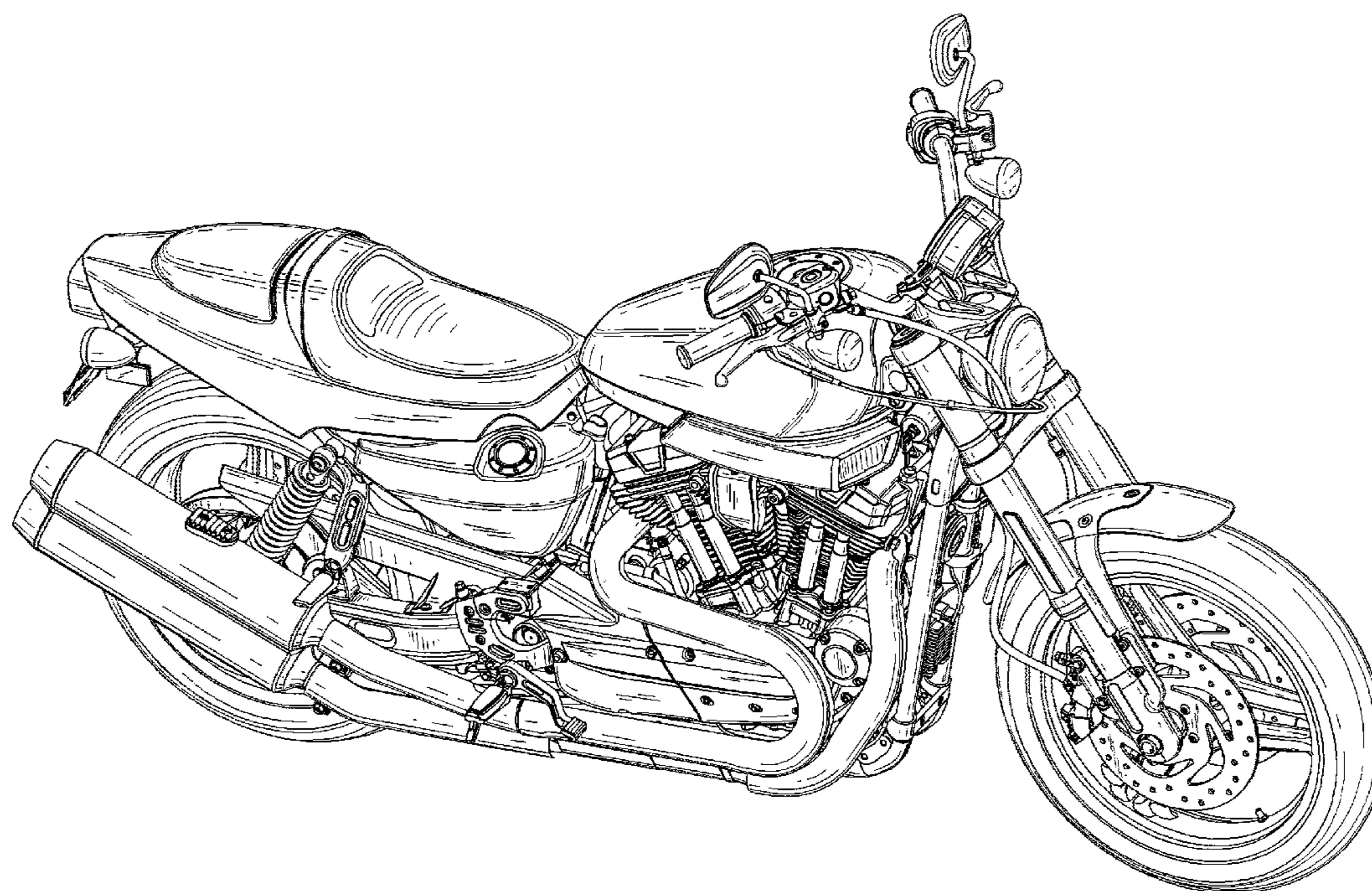

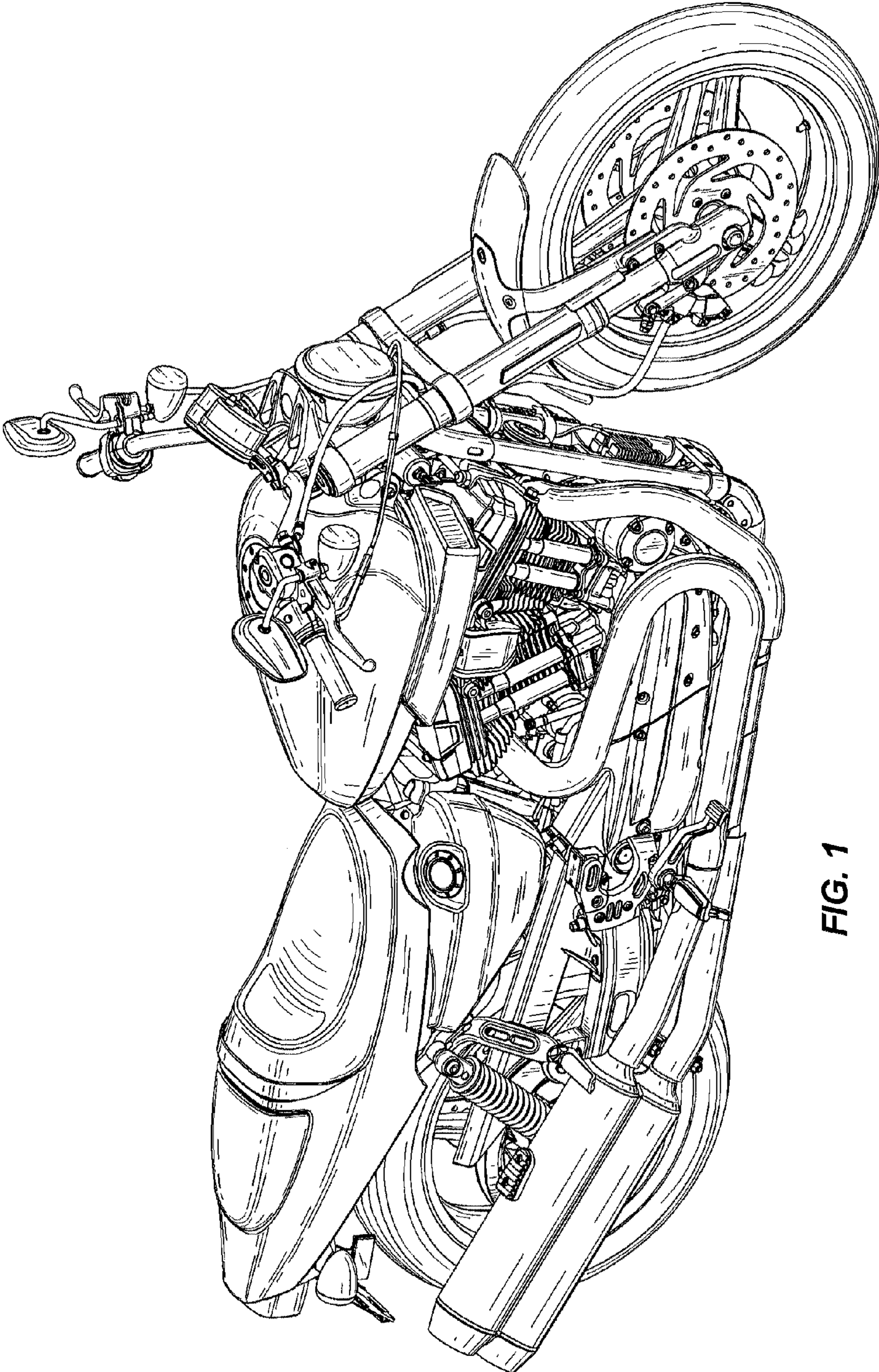

FIG. 1

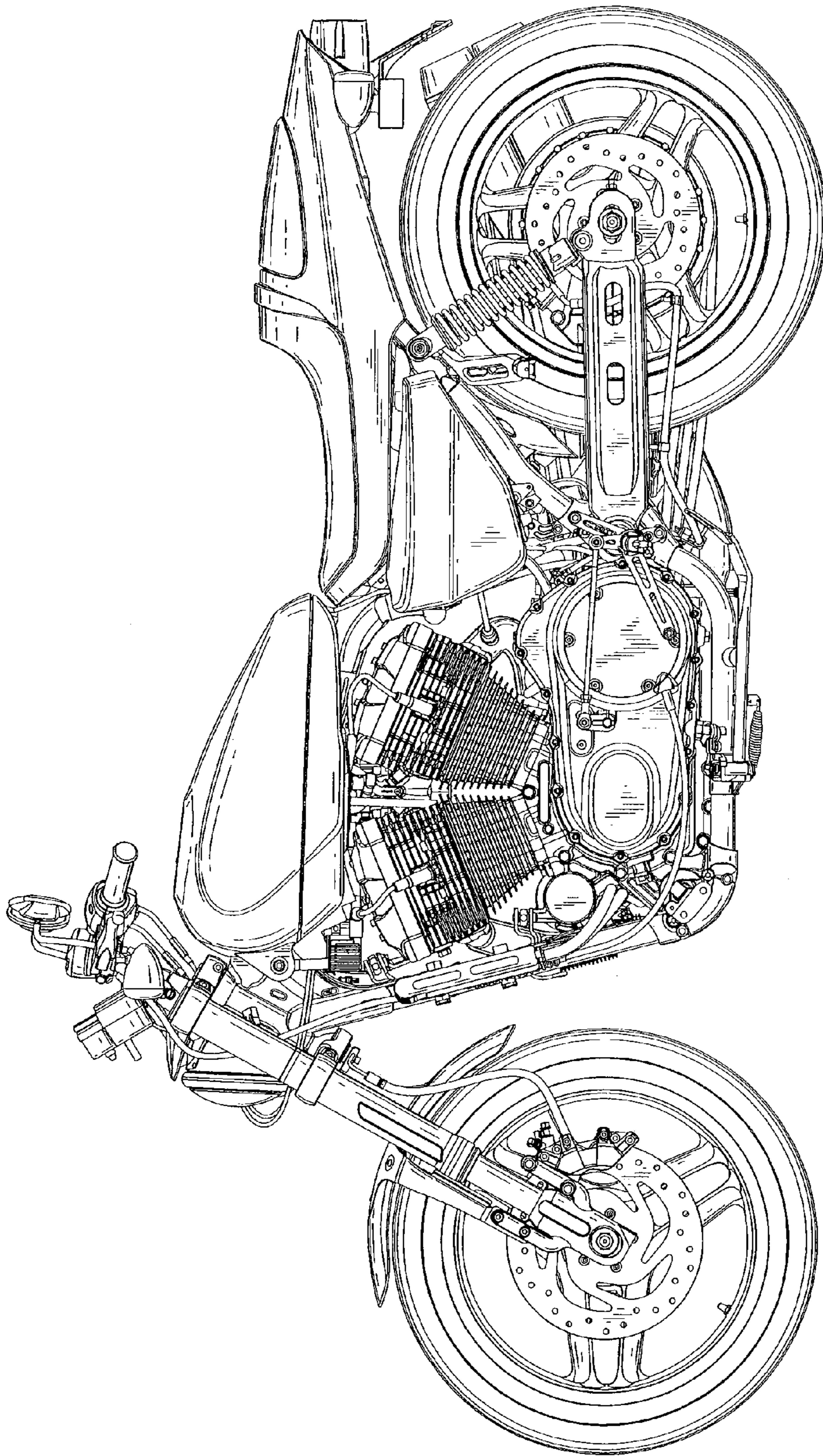

FIG. 2

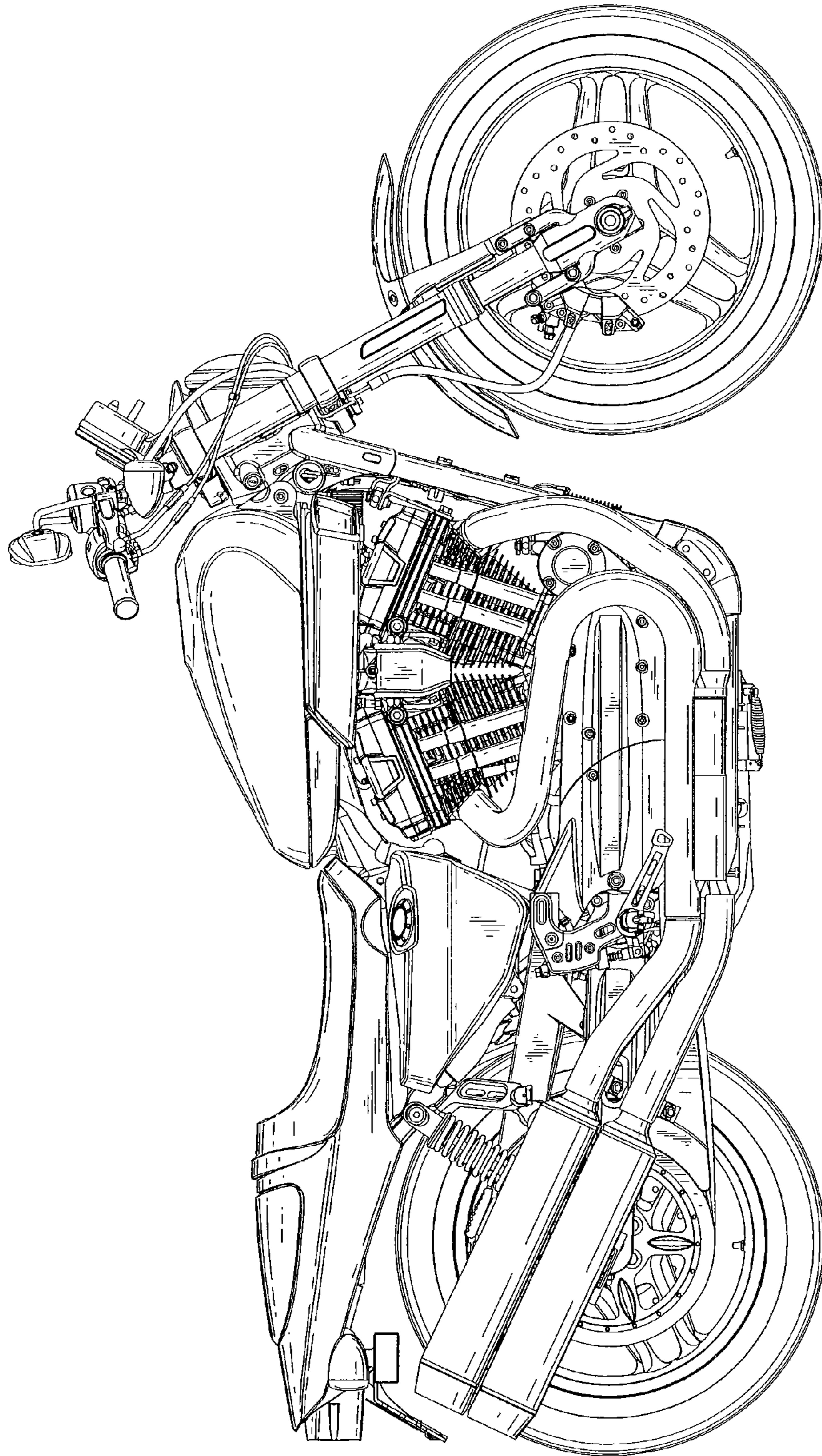

FIG. 3

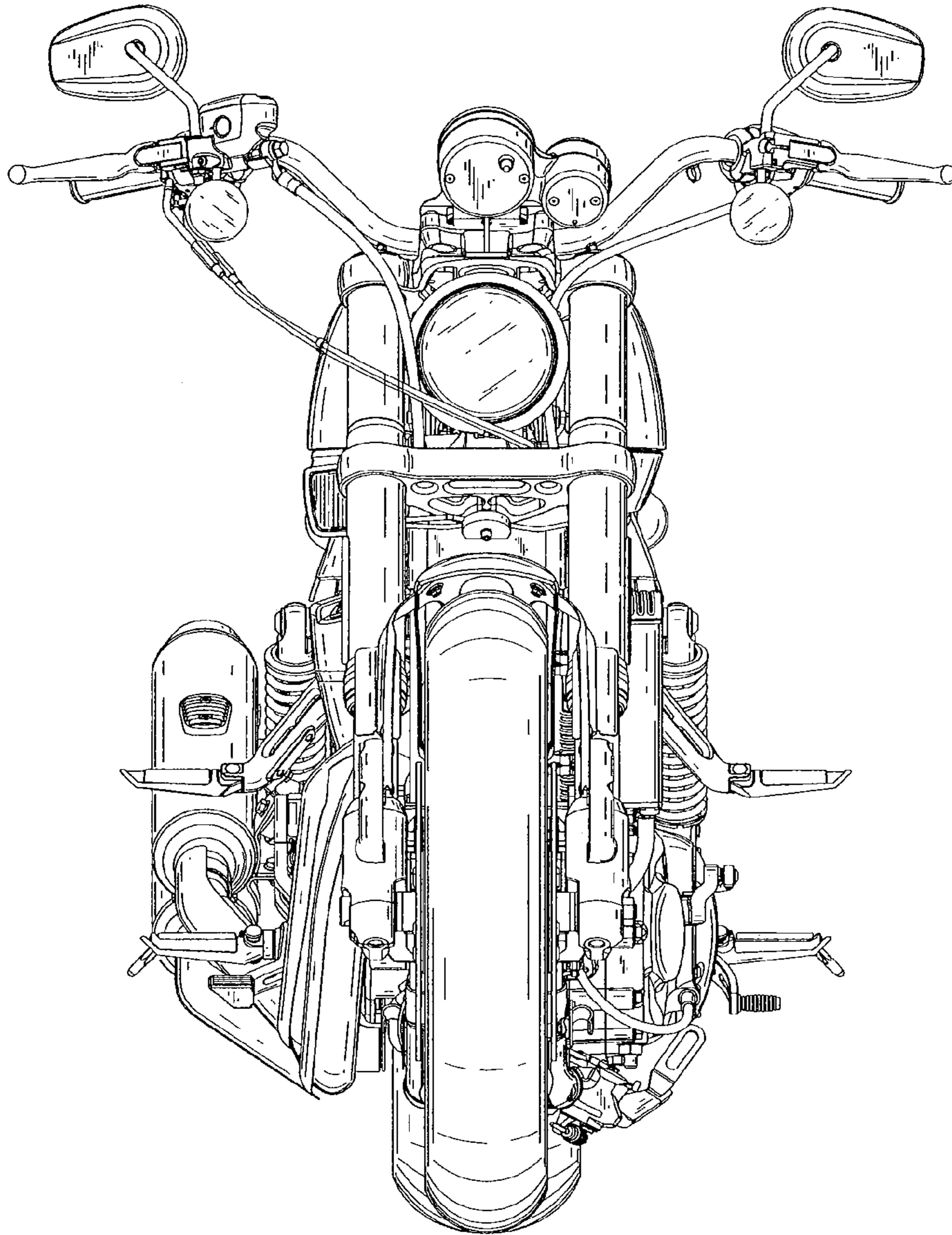

FIG. 4

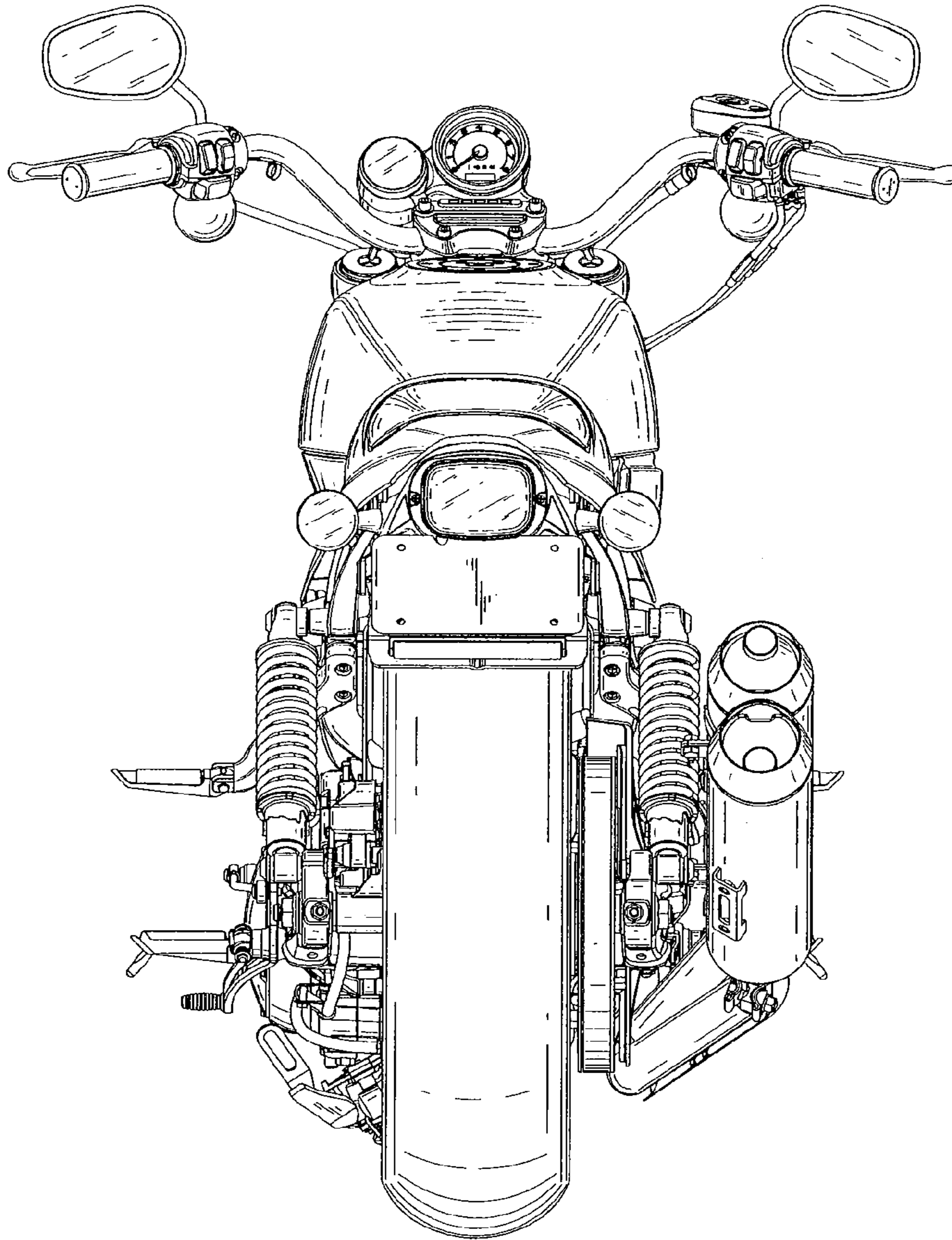

FIG. 5

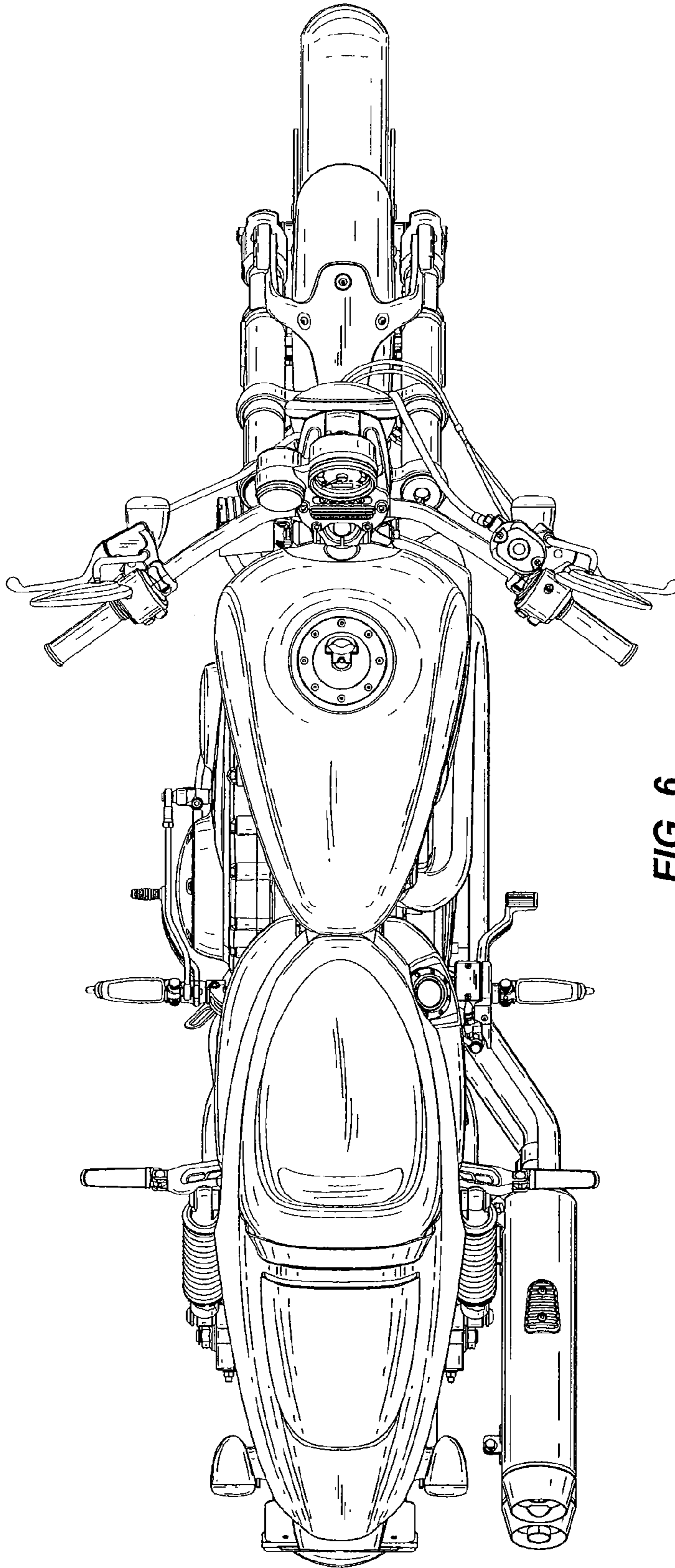

FIG. 6

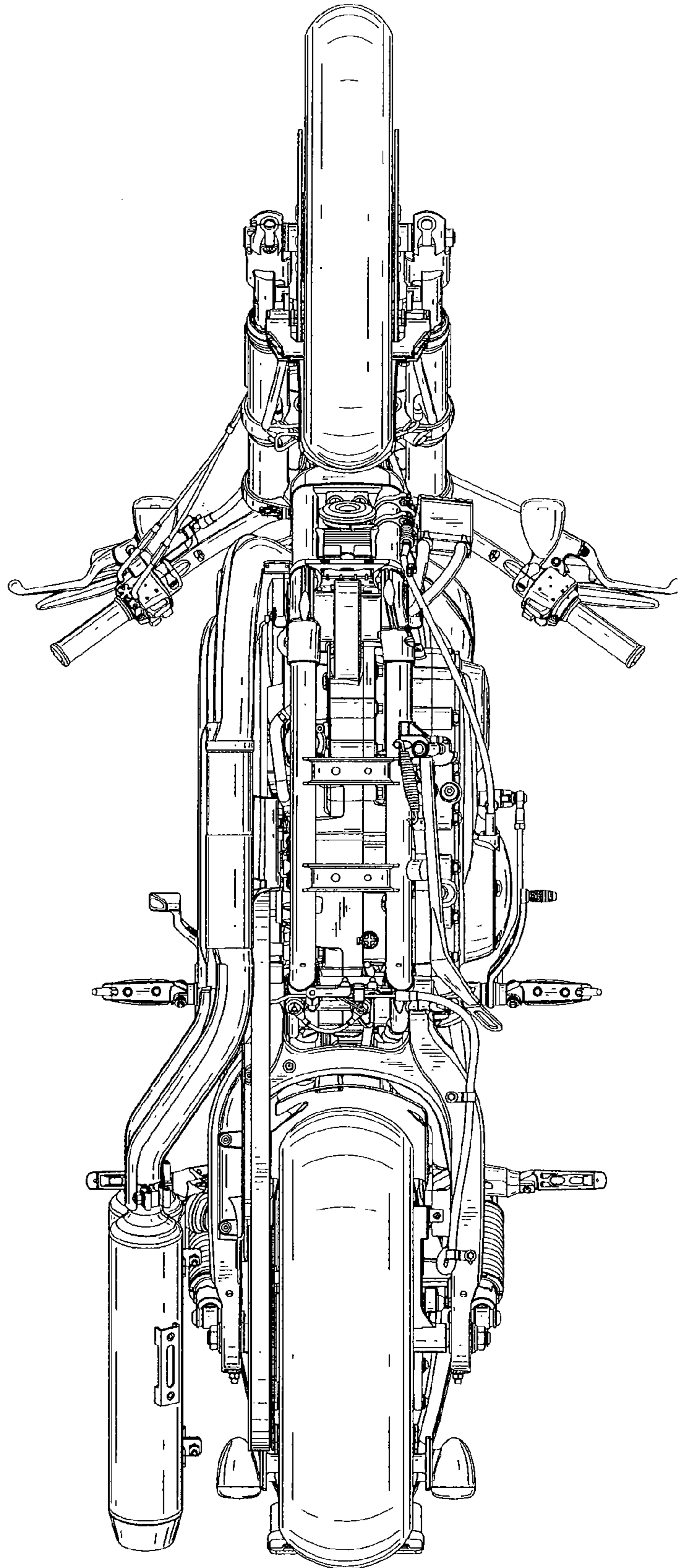

FIG. 7