



US00D544508S

(12) **United States Design Patent** (10) **Patent No.:** **US D544,508 S**
Beno et al. (45) **Date of Patent:** **** Jun. 12, 2007**

(54) **LAMINATOR**

2005/0247405 A1* 11/2005 Murphy et al. 156/555

(75) Inventors: **Steven Beno**, Gurnee, IL (US); **Mikael Bäckström**, Chicago, IL (US)

OTHER PUBLICATIONS

AccuCut® 2003 Education Catalog, p. 24, © 2003.
AccuCut® 2002 Education Catalog, p. 31, © 2001.
AccuCut® 2001 Education Catalog, p. 25, © 2001.
AccuCut® 2000 Education Catalog, p. 34, © 1999.

(73) Assignee: **General Binding Corporation**, Northbrook, IL (US)

* cited by examiner

(**) Term: **14 Years**

Primary Examiner—Antoine D. Davis

(21) Appl. No.: **29/236,082**

Assistant Examiner—Patricia Palasik

(22) Filed: **Aug. 11, 2005**

(74) *Attorney, Agent, or Firm*—Michael Best & Friedrich LLP

(51) **LOC (8) Cl.** **15-99**

(57) **CLAIM**

(52) **U.S. Cl.** **D15/146**

The ornamental design for a laminator, as shown and described.

(58) **Field of Classification Search** D15/145, D15/146; 100/155 R, 160, 176; 156/555, 156/560, 582, 583.1

See application file for complete search history.

DESCRIPTION

(56) **References Cited**

FIG. 1 is a perspective view taken from the top, front, and right side of a laminator showing our new design;

U.S. PATENT DOCUMENTS

FIG. 2 is a perspective view taken from the top, rear, and right side of the laminator shown in FIG. 1;

D342,271 S	12/1993	Keng	
D345,986 S	4/1994	Lim	
D353,604 S	12/1994	Prokop et al.	
D354,966 S	1/1995	Lim	
D354,967 S	1/1995	Lim	
D358,825 S	5/1995	Kuhns	
D358,826 S	5/1995	Kuhns	
D366,883 S	2/1996	Reinders	
6,131,636 A *	10/2000	Anderson et al.	156/555
D440,992 S	4/2001	Parson et al.	
D441,774 S	5/2001	Cheng	
D441,775 S	5/2001	Cheng	
D442,199 S	5/2001	Cheng	
D442,980 S	5/2001	Johnson et al.	
D443,883 S *	6/2001	Reuter	D15/146
D453,171 S	1/2002	Cheng	
D453,172 S	1/2002	Cheng	
D454,895 S *	3/2002	Sakata et al.	D15/146
D512,734 S *	12/2005	Messina et al.	D15/146
D534,192 S *	12/2006	Kiple et al.	D15/145
2002/0117266 A1	8/2002	Han	

FIG. 3 is a top plan view of the laminator shown in FIG. 1;

FIG. 4 is a bottom view of the laminator shown in FIG. 1;

FIG. 5 is a front elevational view of the laminator shown in FIG. 1;

FIG. 6 is a rear elevational view of the laminator shown in FIG. 1;

FIG. 7 is a left elevational side view of the laminator shown in FIG. 1;

FIG. 8 is a right elevational side view of the laminator shown in FIG. 1;

FIG. 9 is a perspective view taken from the top, front, and right side of another embodiment of a laminator showing our new design;

FIG. 10 is a perspective view taken from the top, rear, and right side of the laminator shown in FIG. 9;

FIG. 11 is a top plan view of the laminator shown in FIG. 9;

FIG. 12 is a bottom view of the laminator shown in FIG. 9;

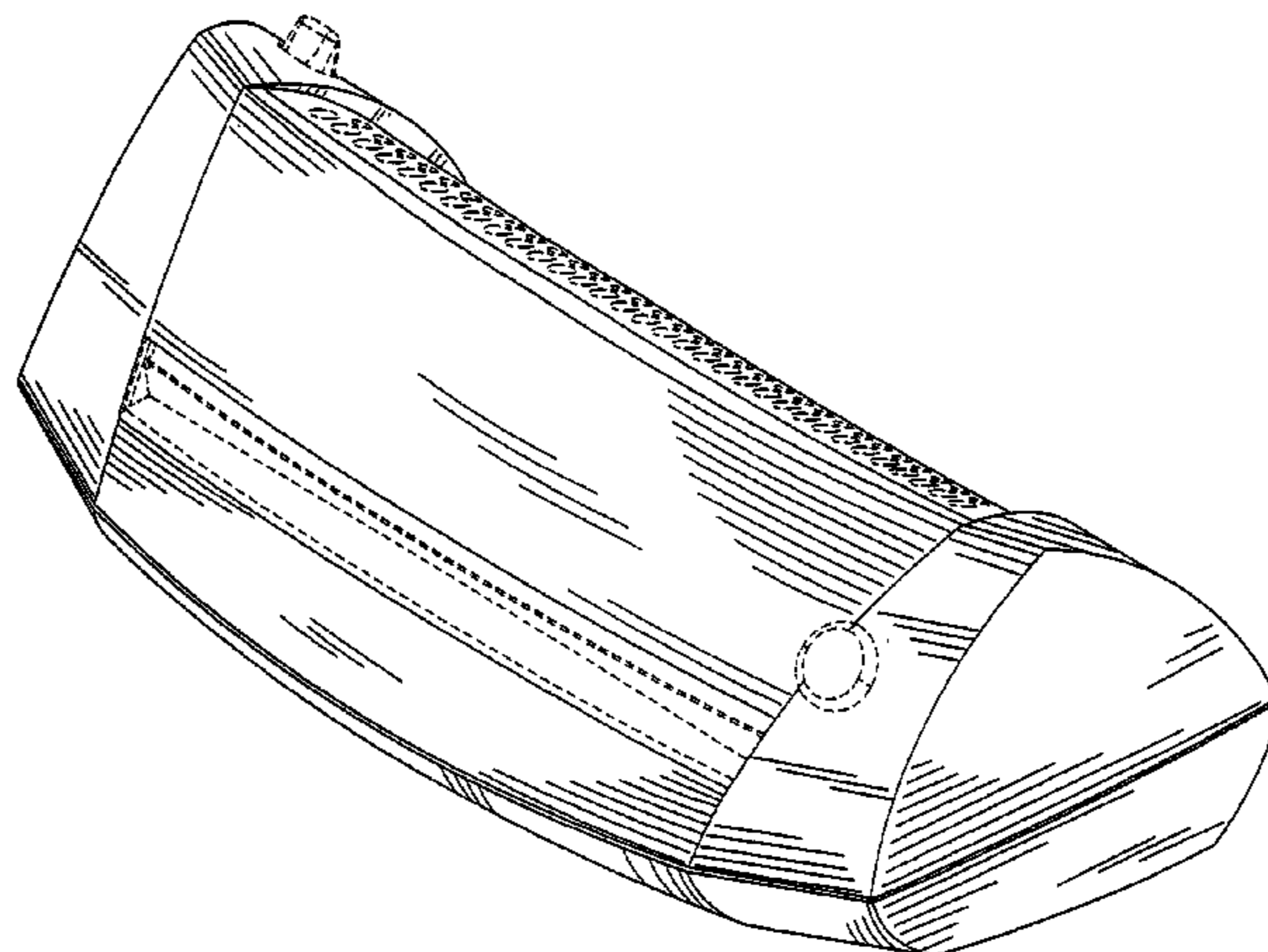

FIG. 13 is a front elevational view of the laminator shown in FIG. 9;

FIG. 14 is a rear elevational view of the laminator shown in FIG. 9;

FIG. 15 is a left elevational side view of the laminator shown in FIG. 9;

FIG. 16 is a right elevational side view of the laminator shown in FIG. 9;

FIG. 17 is a perspective view taken from the top, front, and right side of another embodiment of a laminator showing our new design;

FIG. 18 is a perspective view taken from the top, rear, and right side of the laminator shown in FIG. 17;

FIG. 19 is a top plan view of the laminator shown in FIG. 17;

FIG. 20 is a bottom view of the laminator shown in FIG. 17;

FIG. 21 is a front elevational view of the laminator shown in FIG. 17;

FIG. 22 is a rear elevational view of the laminator shown in FIG. 17;

FIG. 23 is a left elevational side view of the laminator shown in FIG. 17;

FIG. 24 is a right elevational side view of the laminator shown in FIG. 17;

FIG. 25 is a perspective view taken from the top, front, and right side of another embodiment of a laminator showing our new design;

FIG. 26 is a perspective view taken from the top, rear, and right side of the laminator shown in FIG. 25;

FIG. 27 is a top plan view of the laminator shown in FIG. 25;

FIG. 28 is a bottom view of the laminator shown in FIG. 25;

FIG. 29 is a front elevational view of the laminator shown in FIG. 25;

FIG. 30 is a rear elevational view of the laminator shown in FIG. 25;

FIG. 31 is a left elevational view of the laminator shown in FIG. 25; and,

FIG. 32 is a right elevational side view of the laminator shown in FIG. 25.

The broken lines are for illustration purposes only and form no part of the claimed design.

1 Claim, 32 Drawing Sheets

FIG. 1

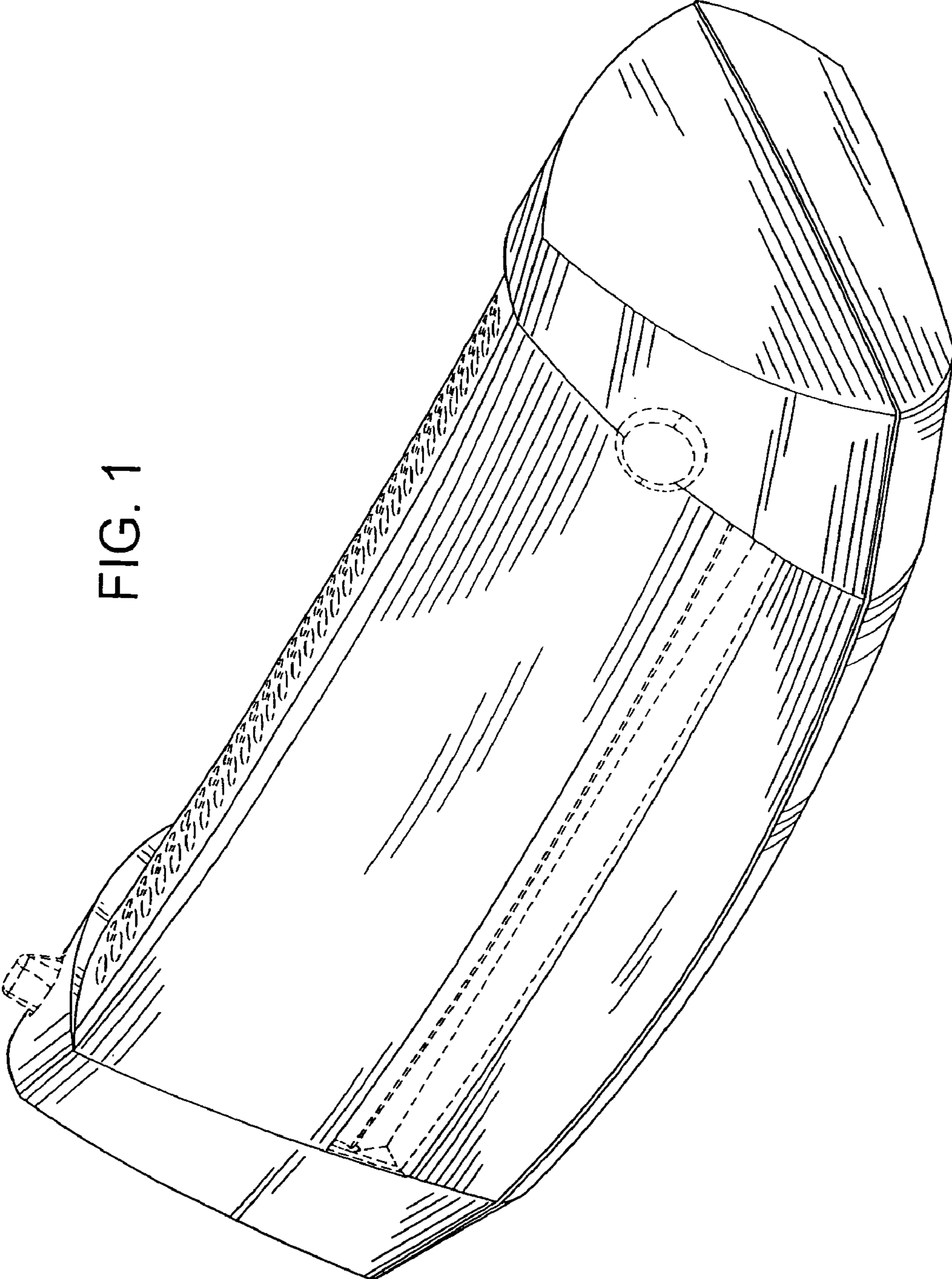

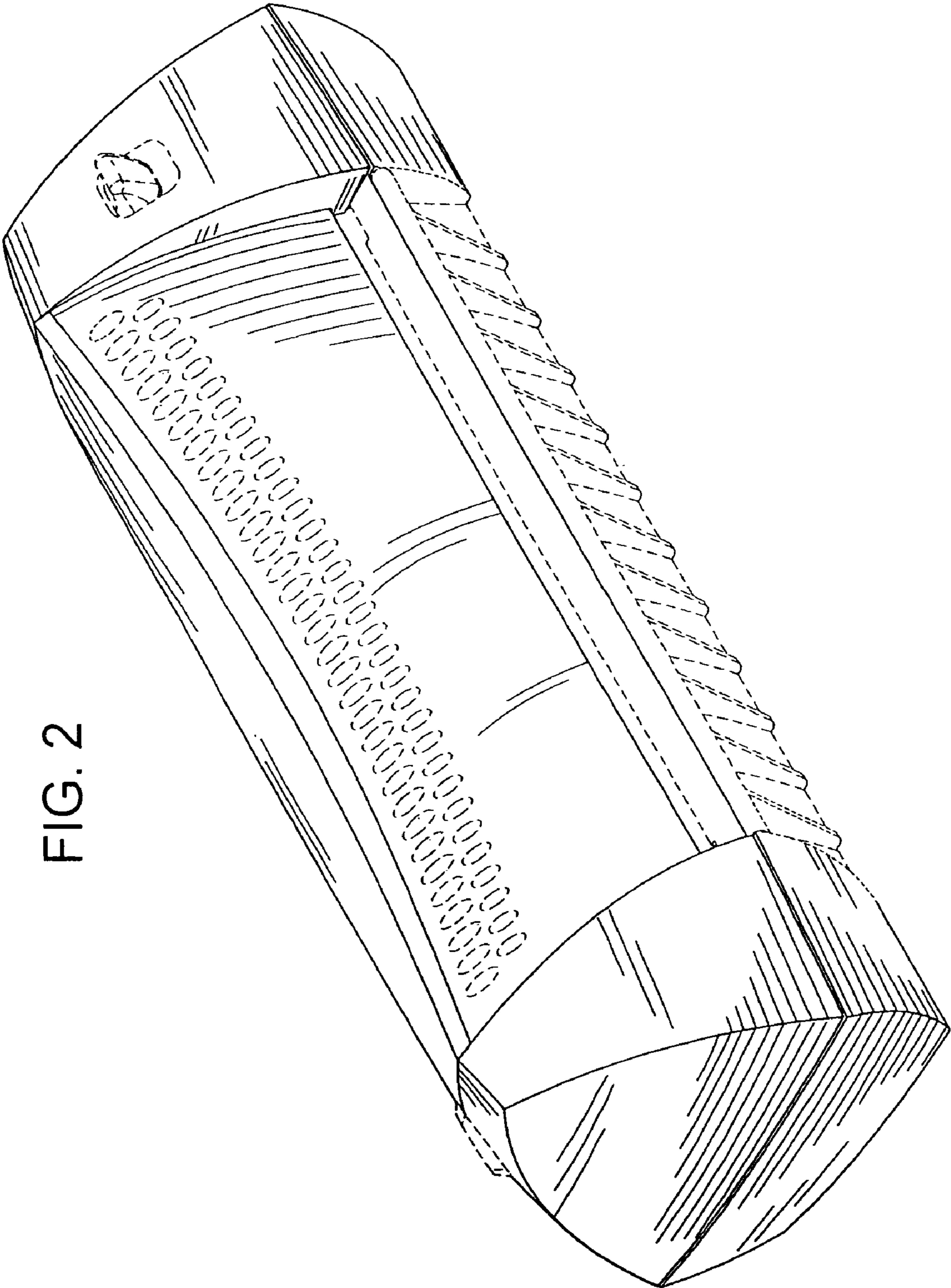

FIG. 2

FIG. 3

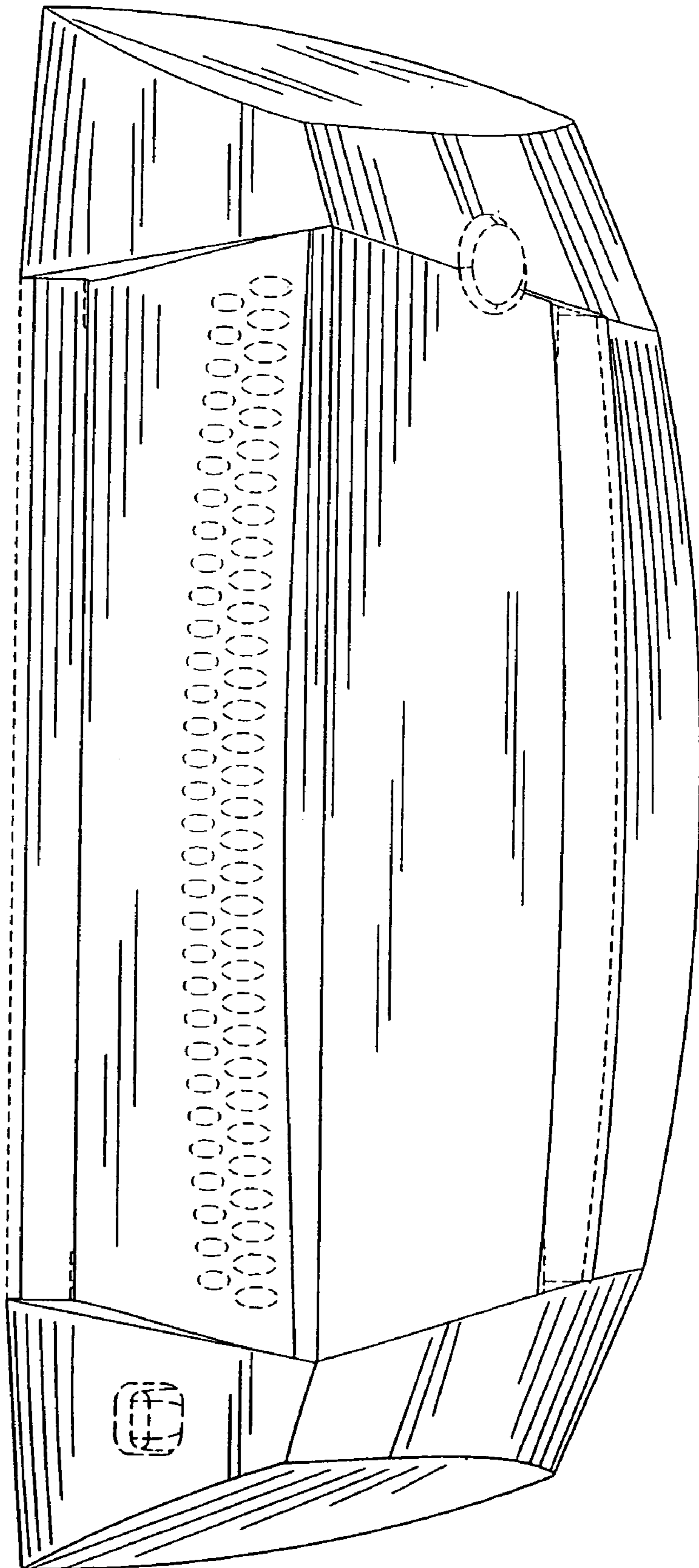

FIG. 4

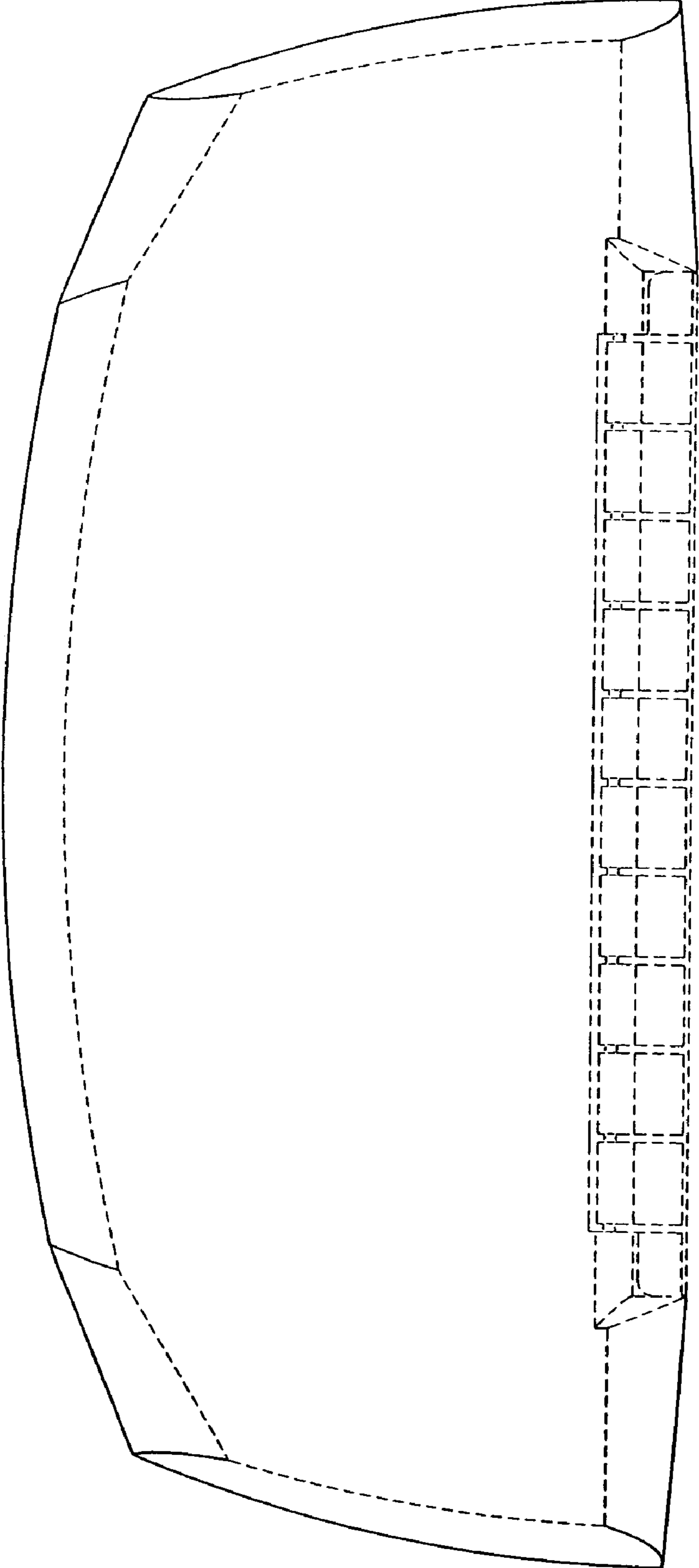

FIG. 5

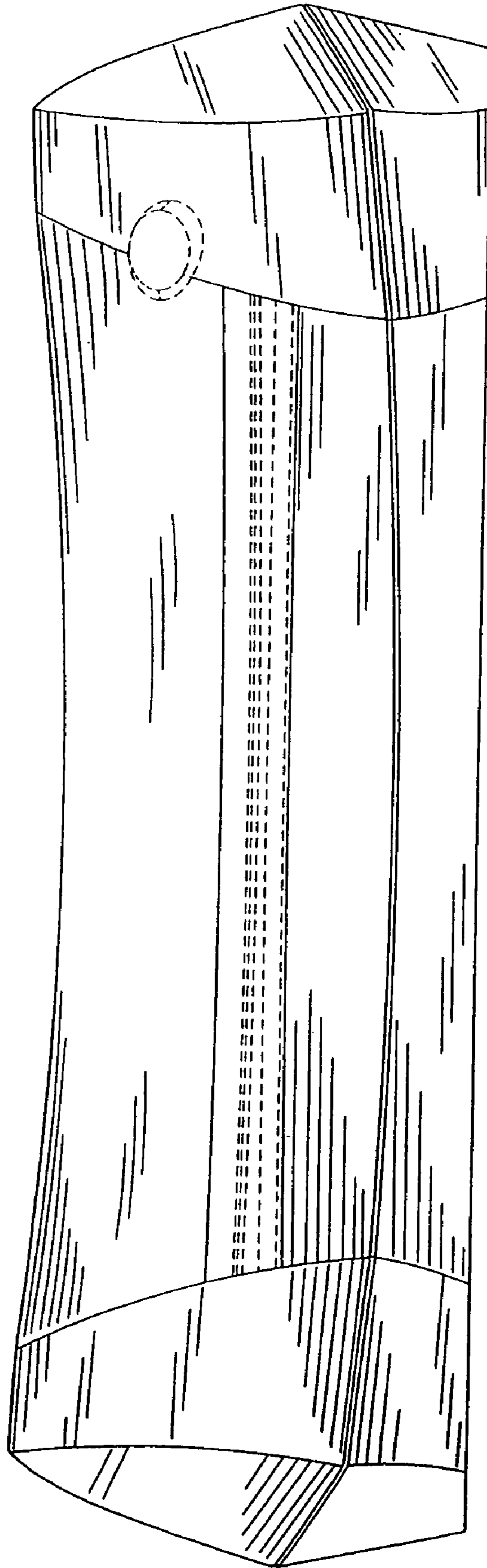

FIG. 6

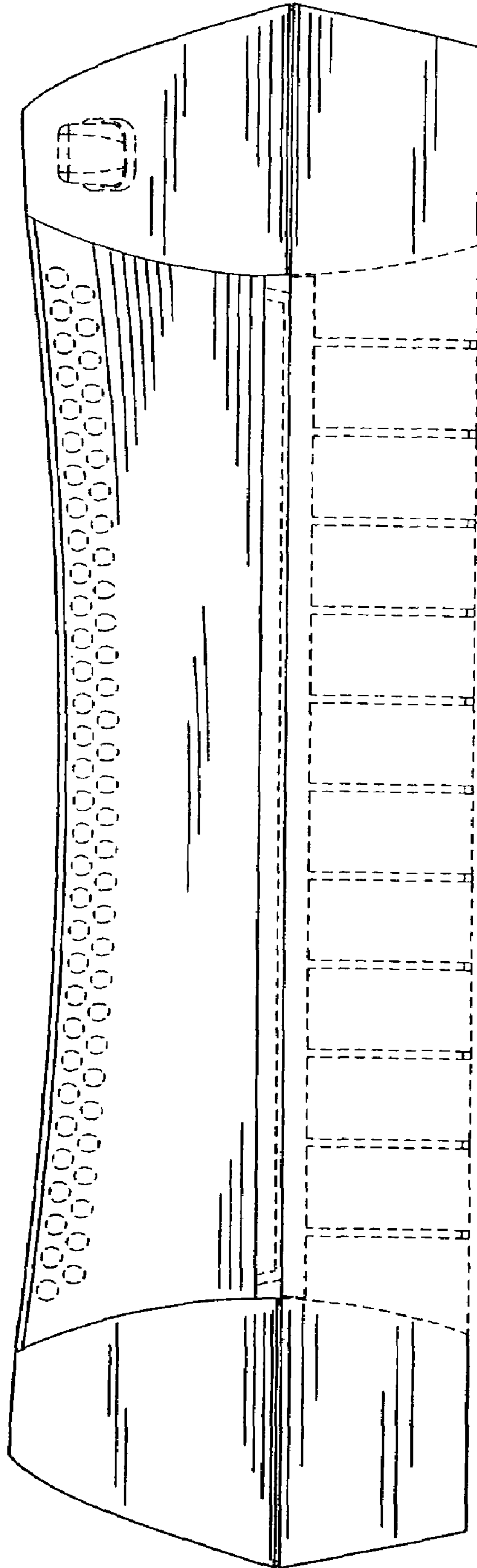

FIG. 7

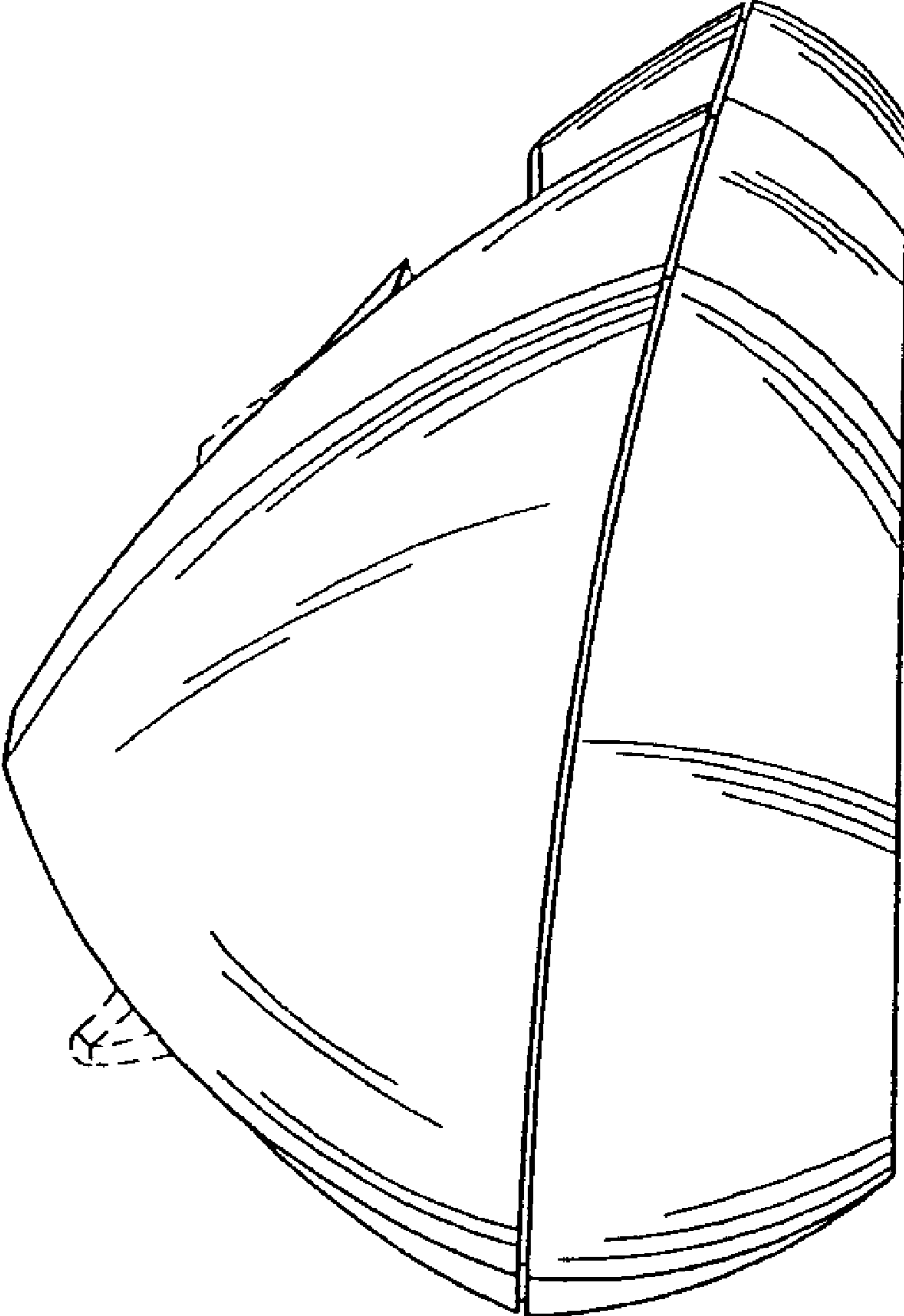

FIG. 8

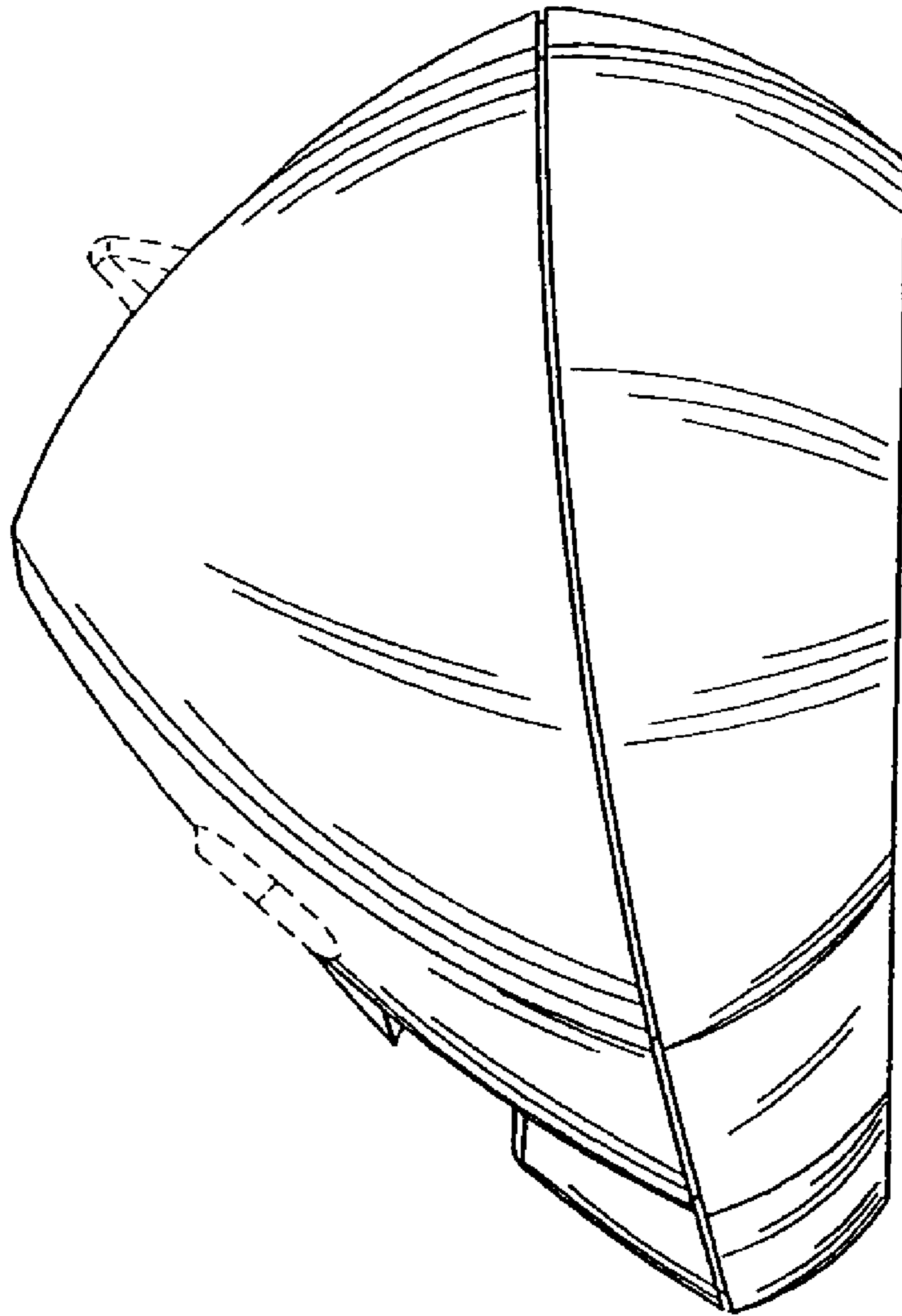
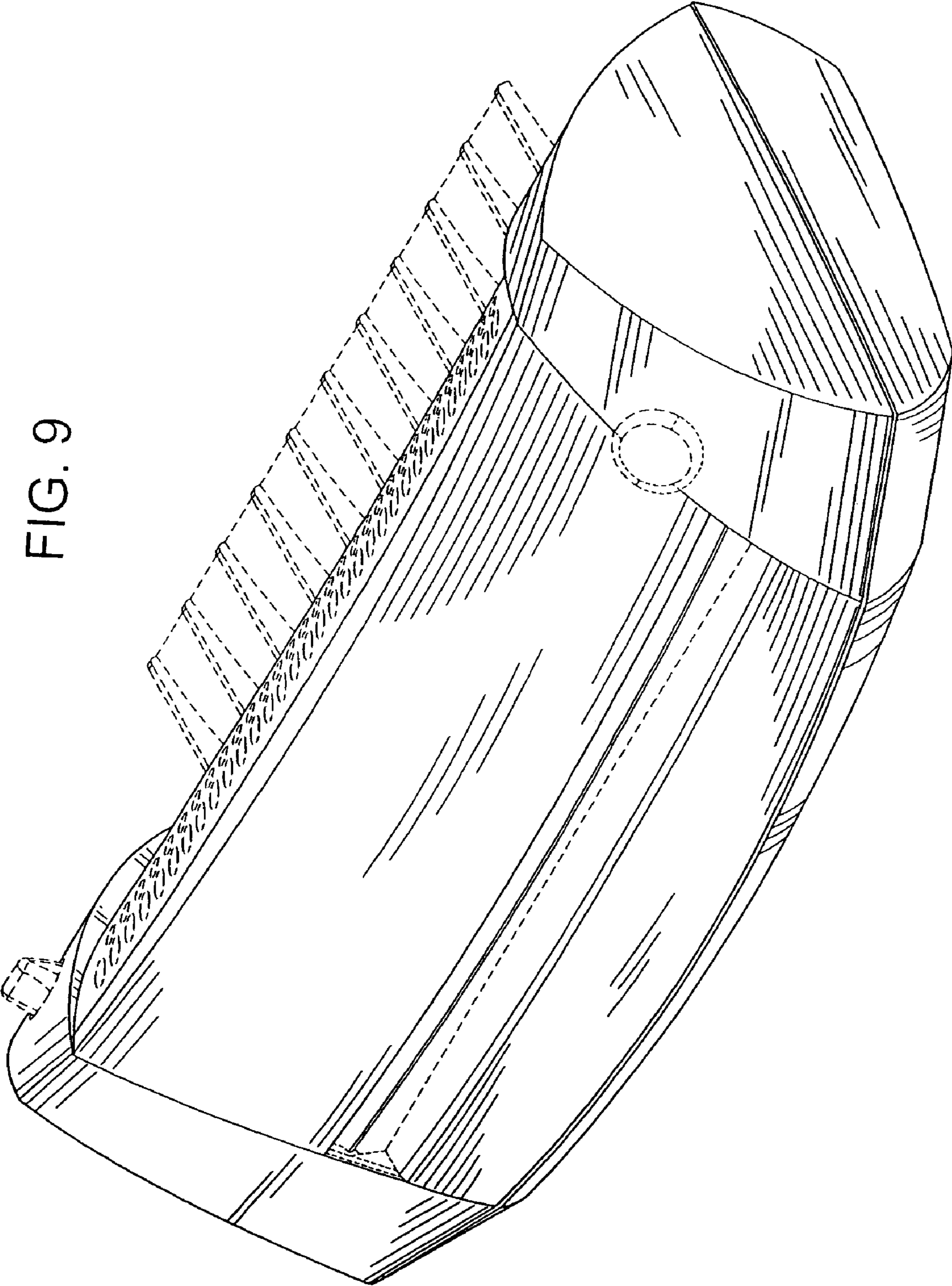

FIG. 9



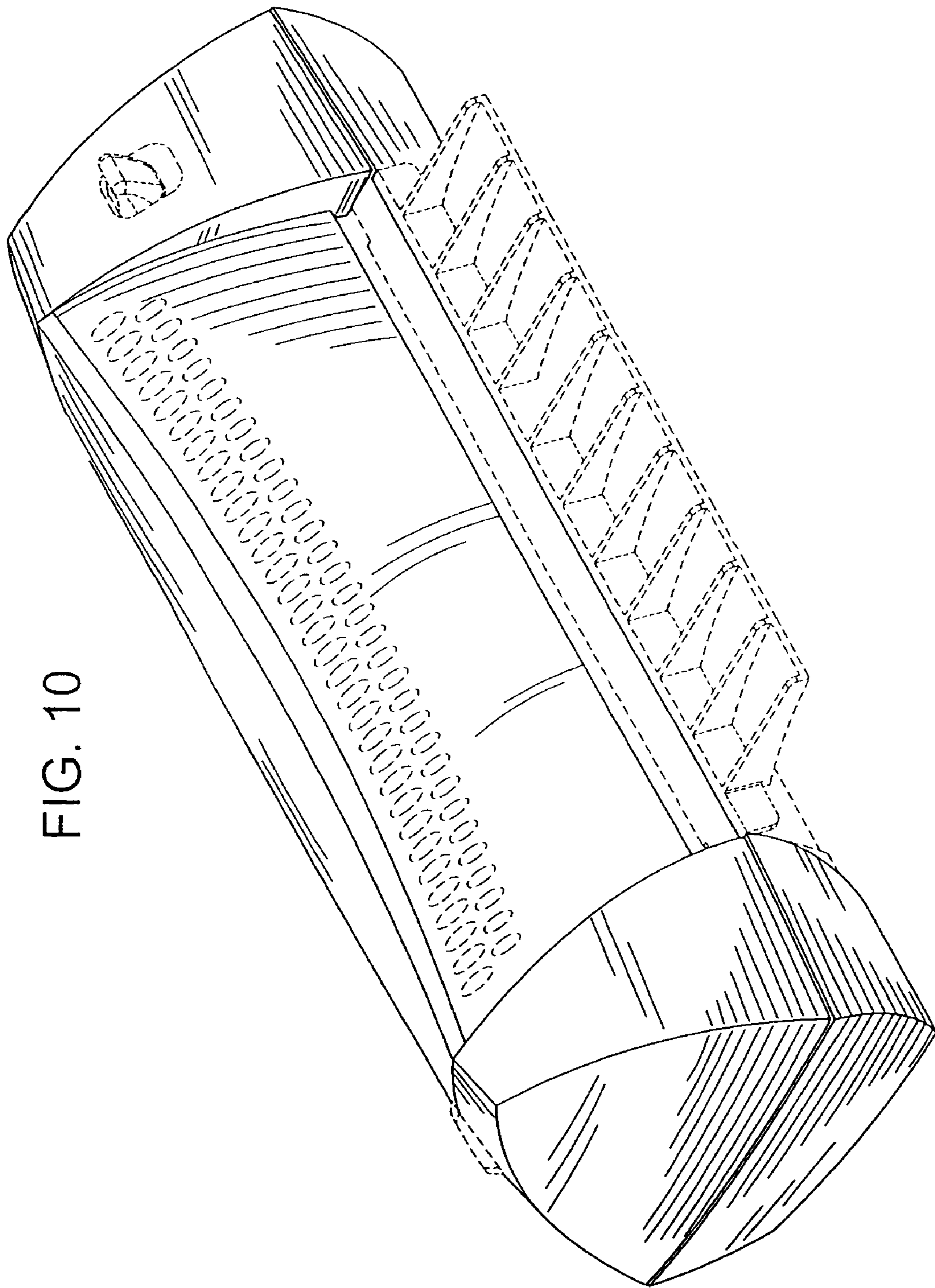

FIG. 10

FIG. 11

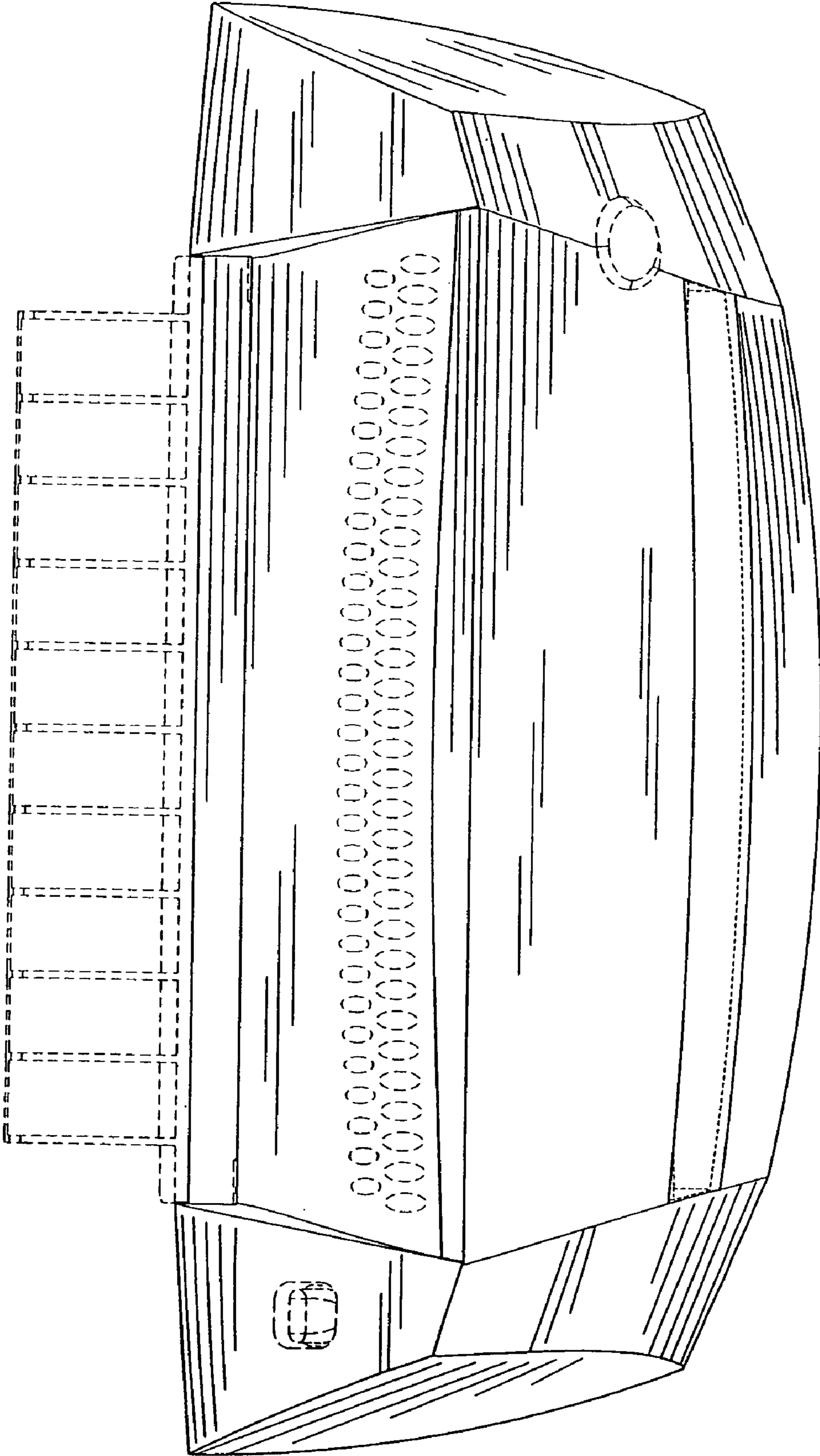

FIG. 12

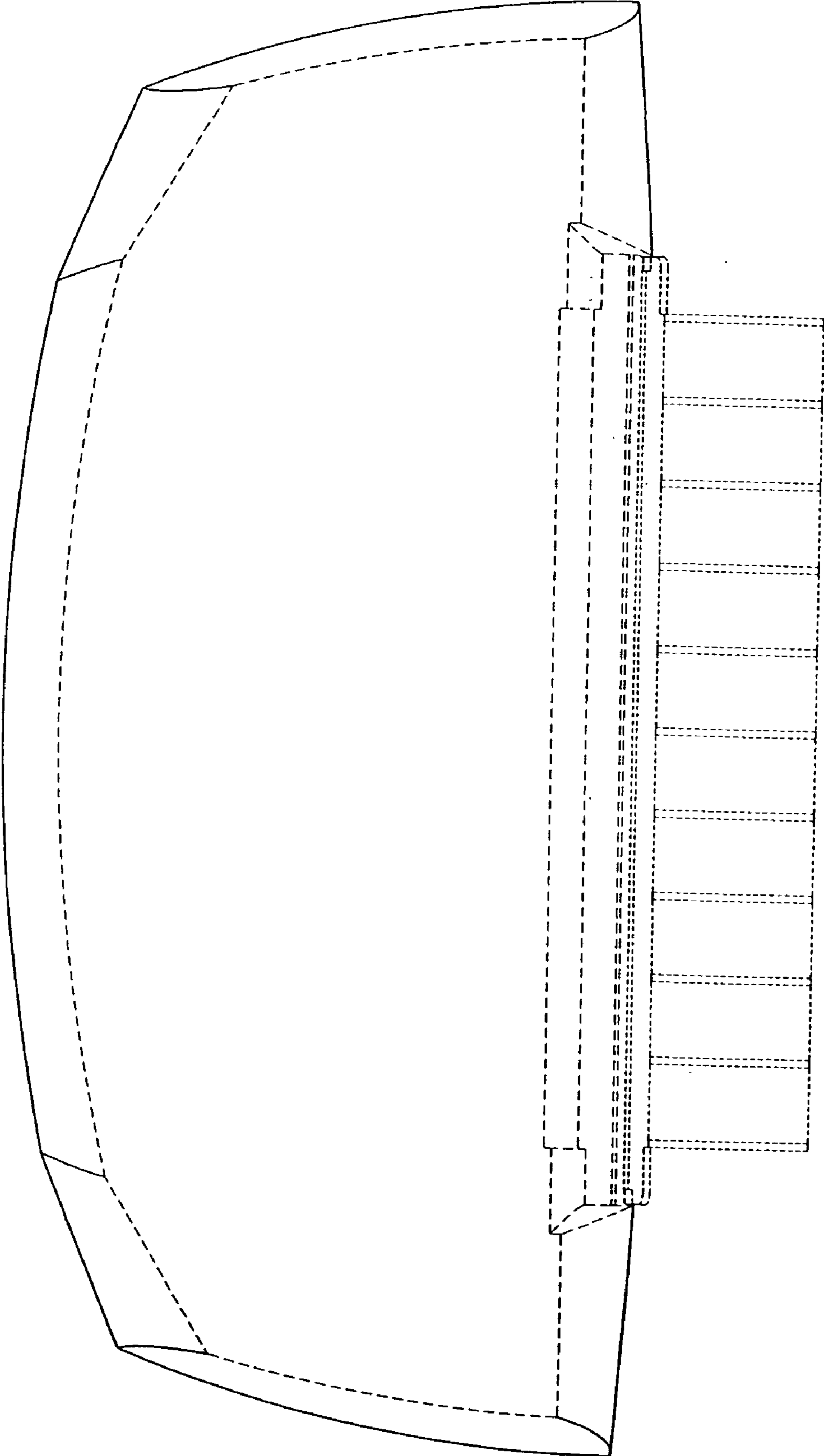

FIG. 13

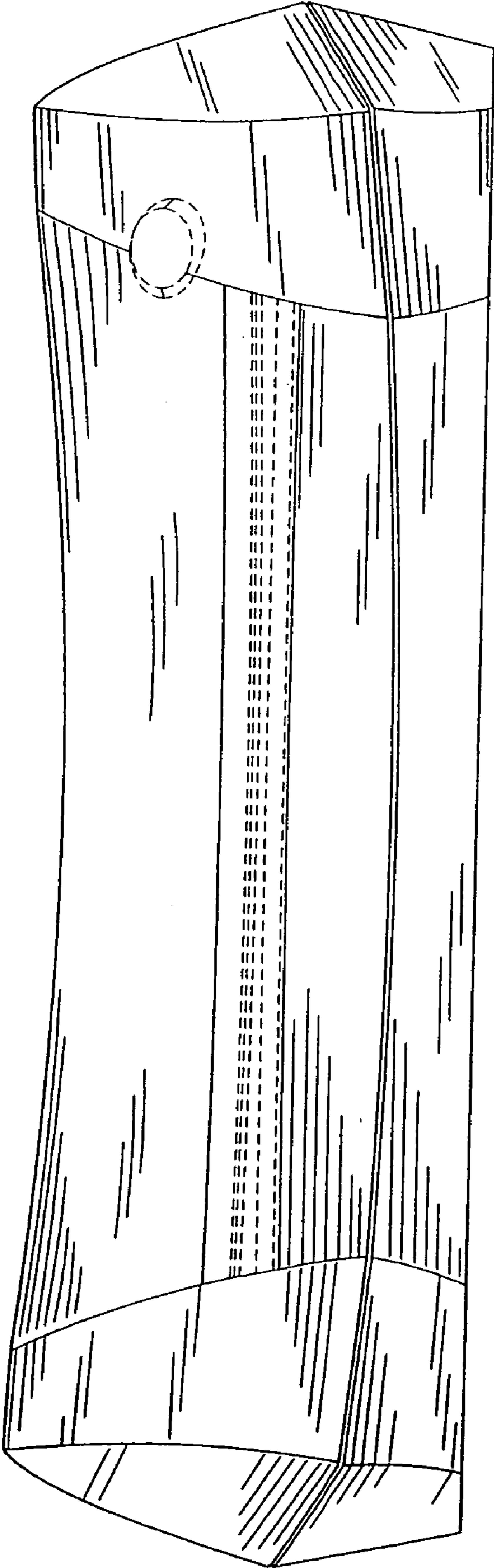

FIG. 14

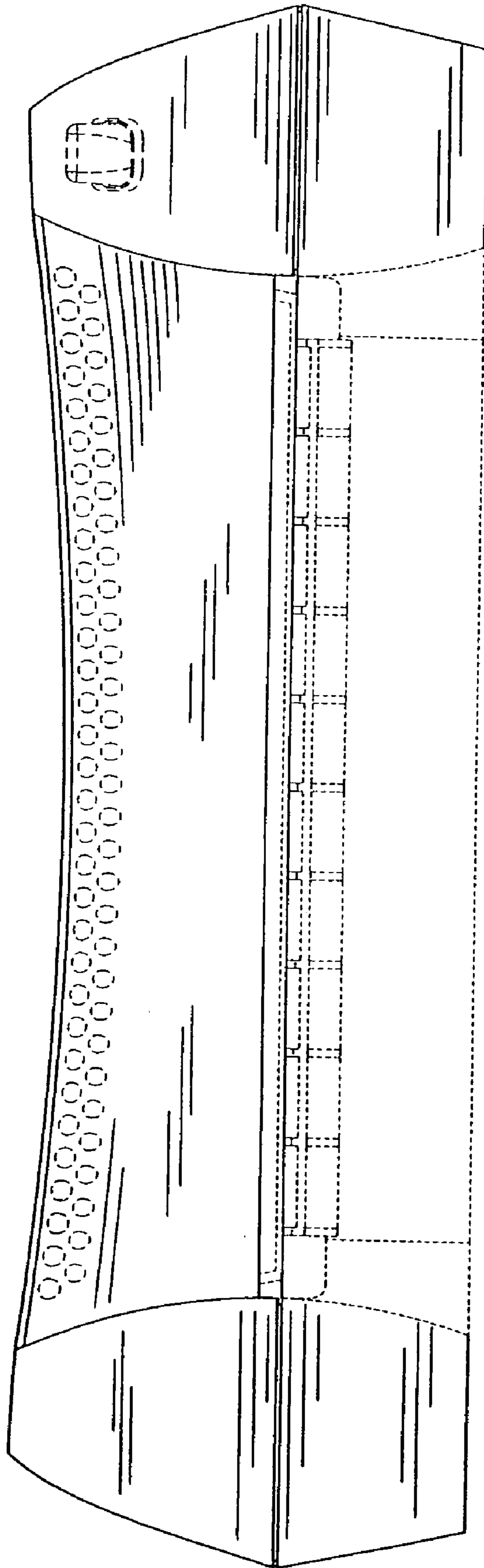

FIG. 15

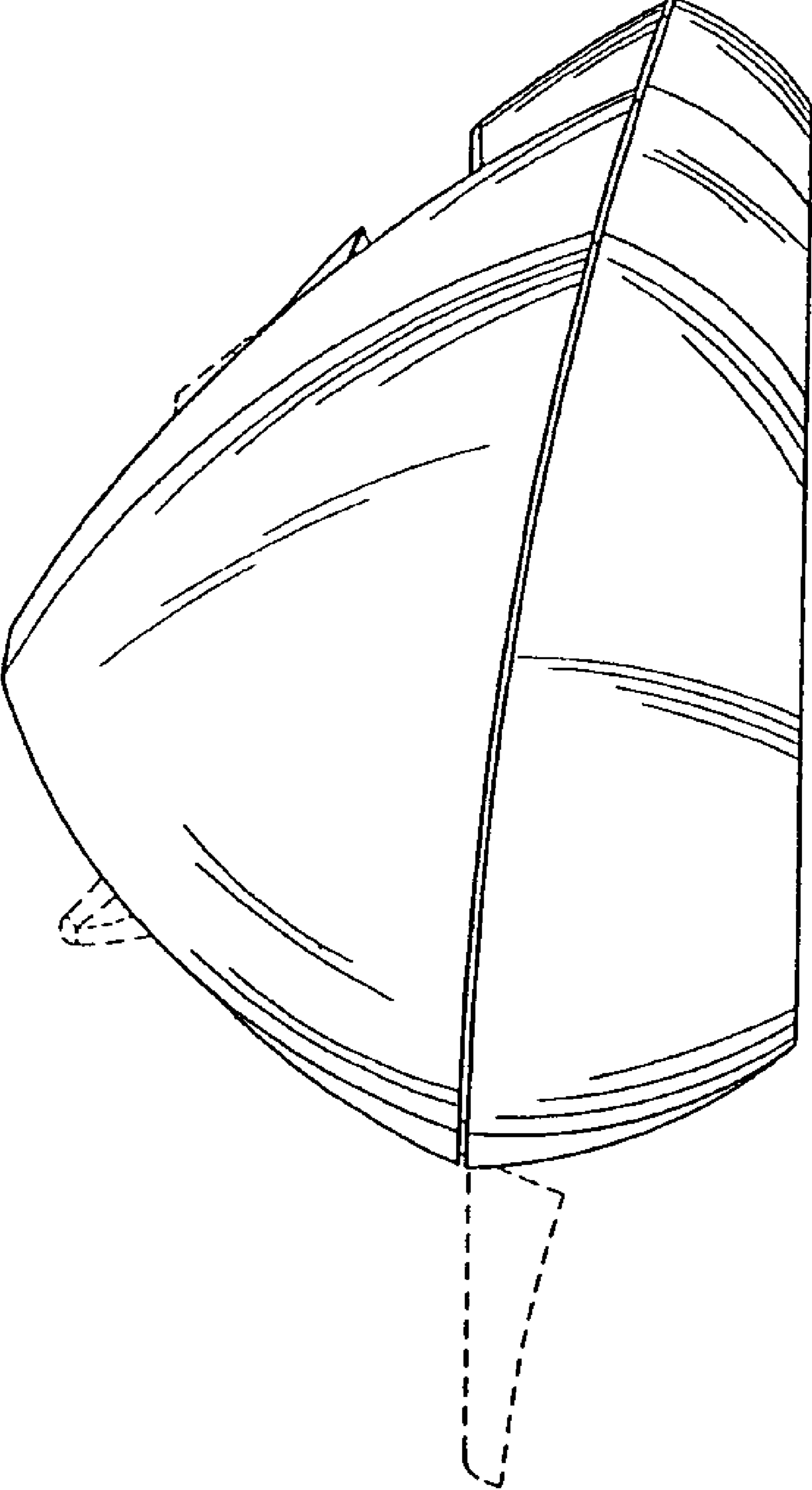

FIG. 16

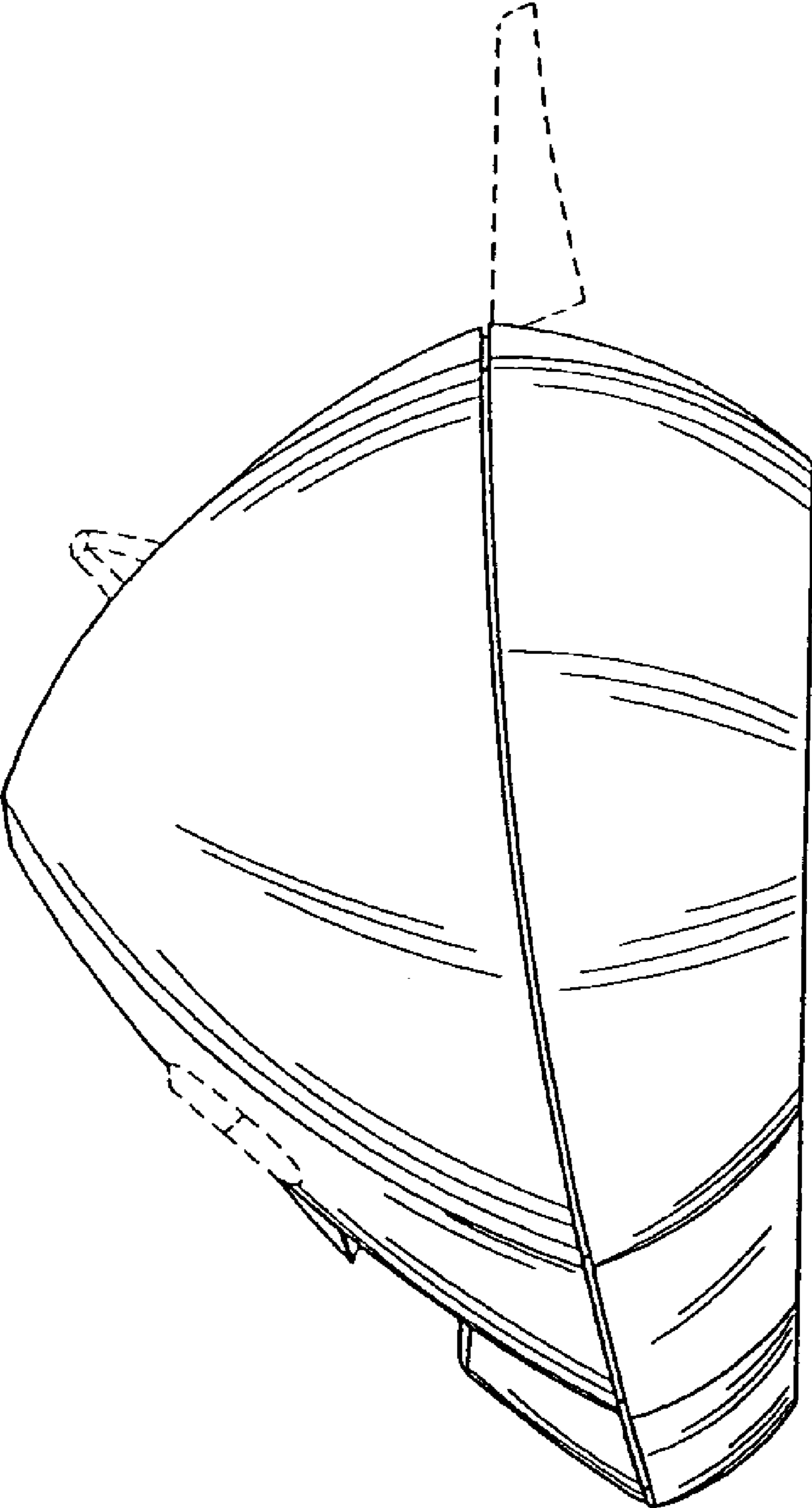
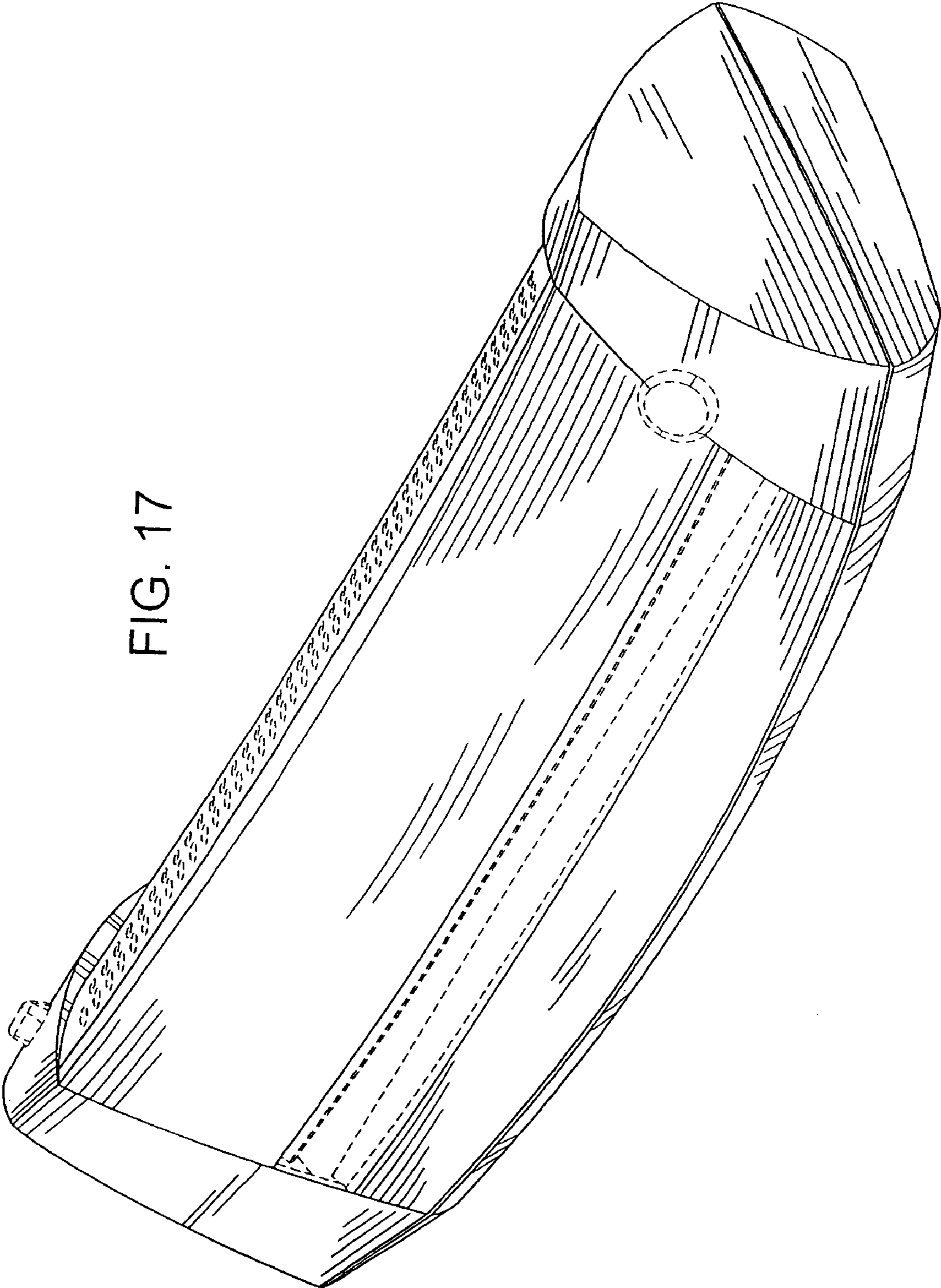

FIG. 17



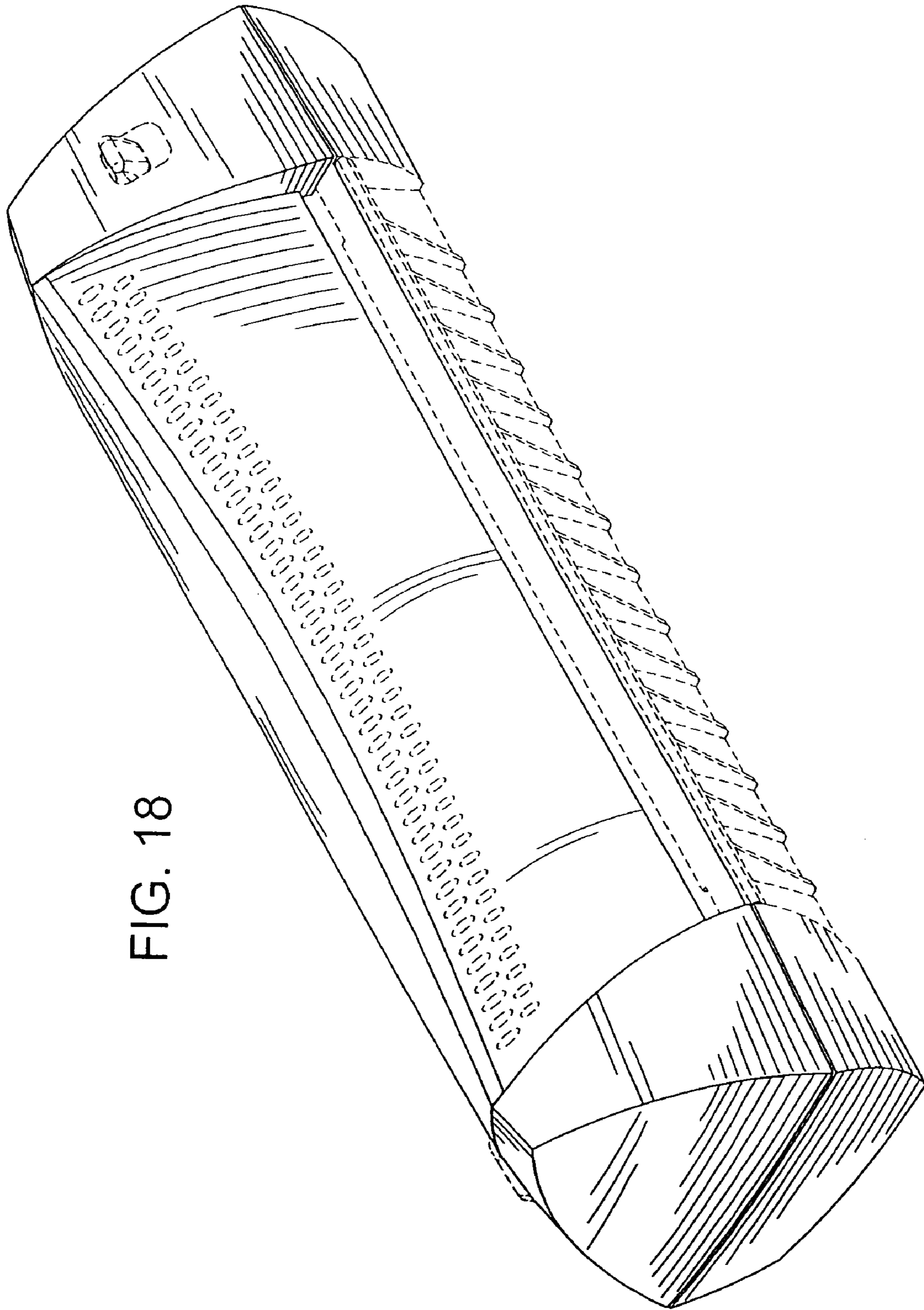

FIG. 18

FIG. 19

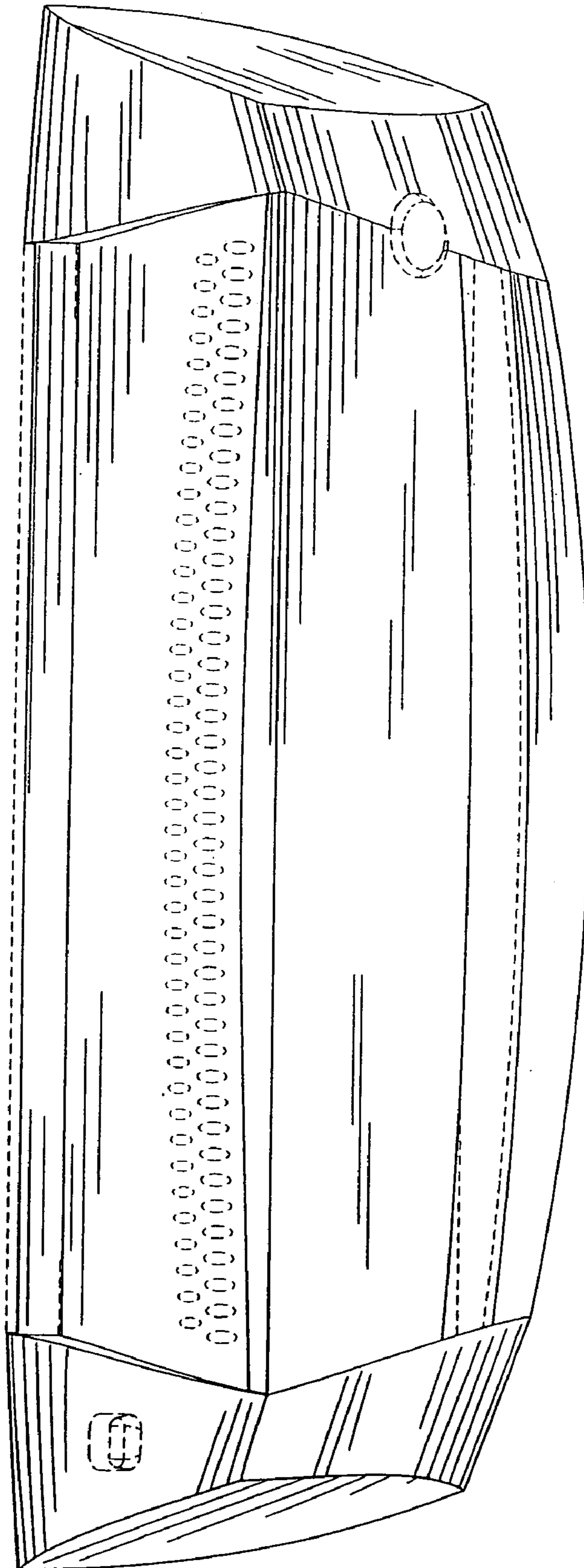

FIG. 20

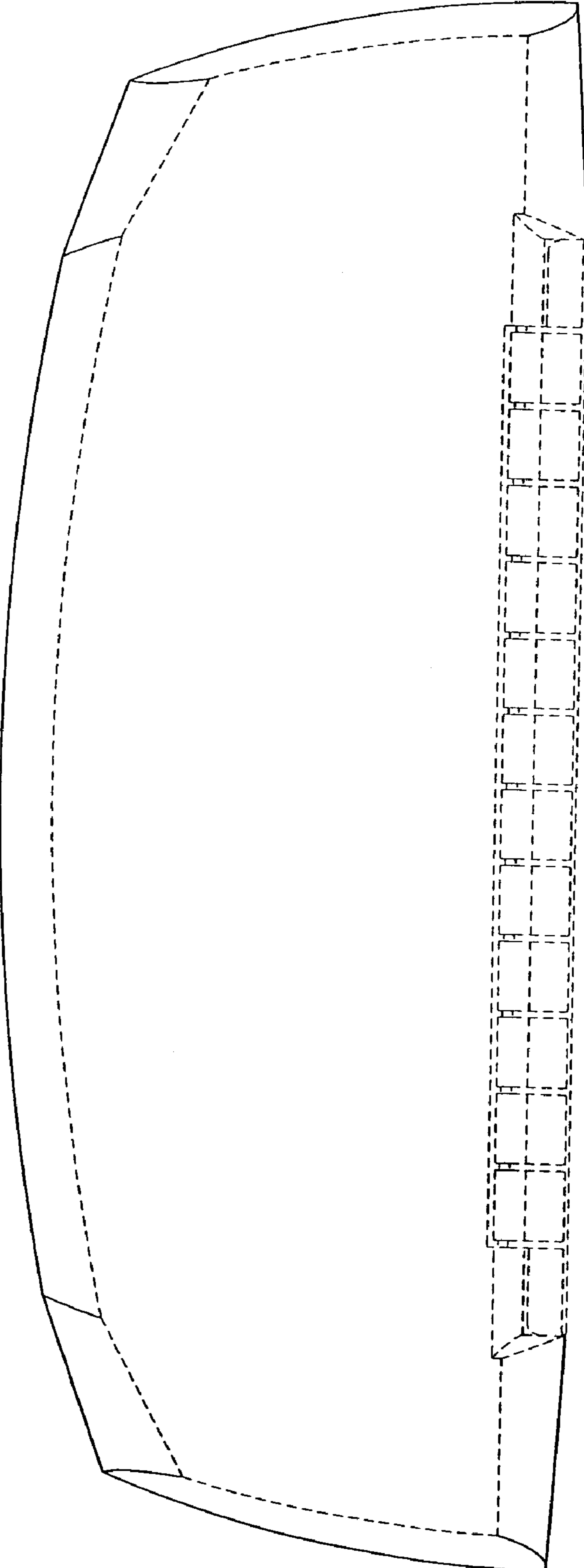

FIG. 21

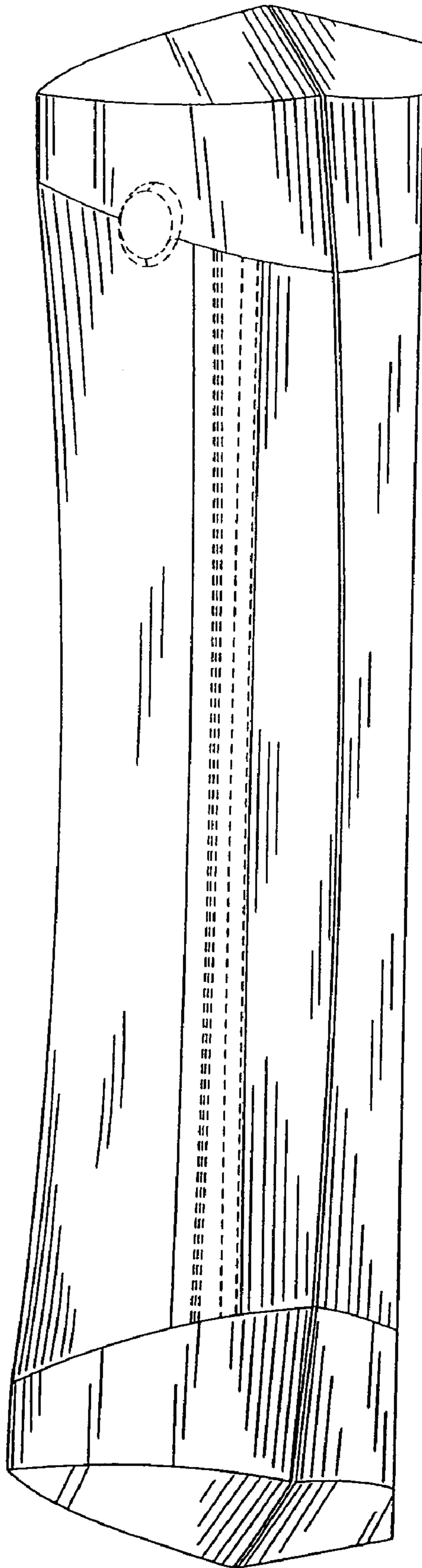

FIG. 22

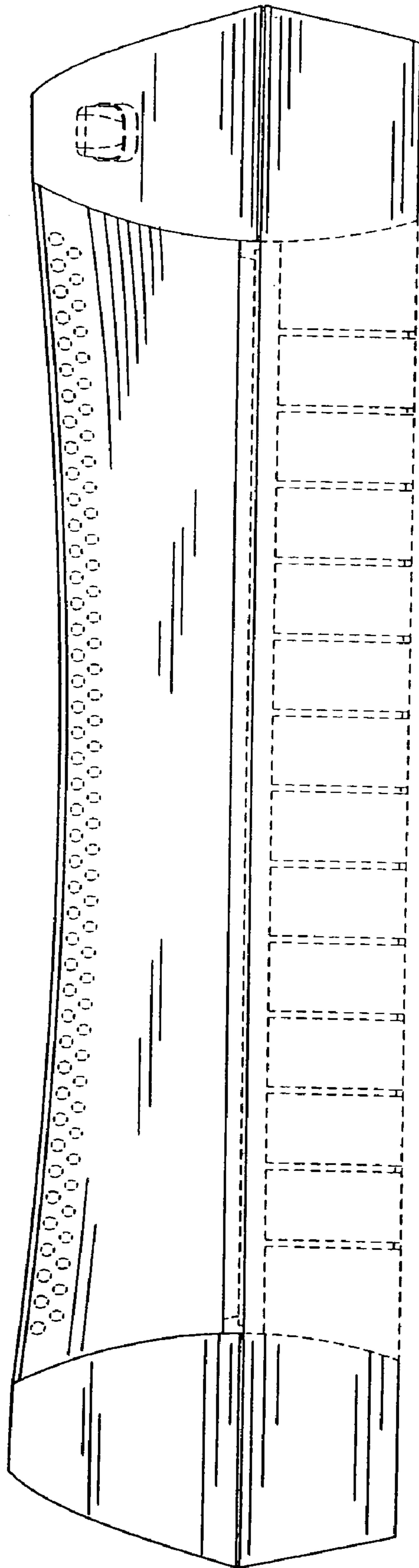

FIG. 23

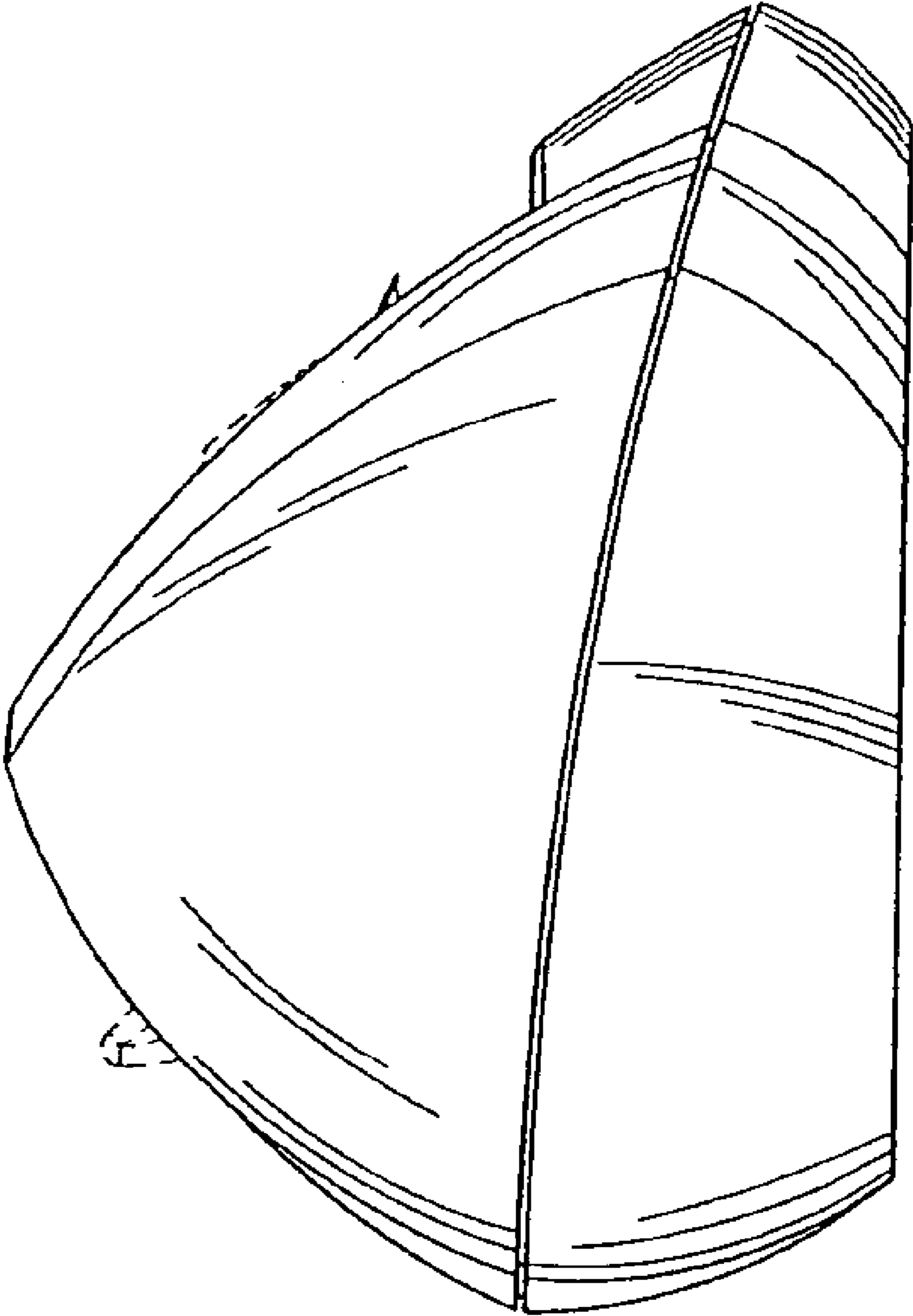

FIG. 24

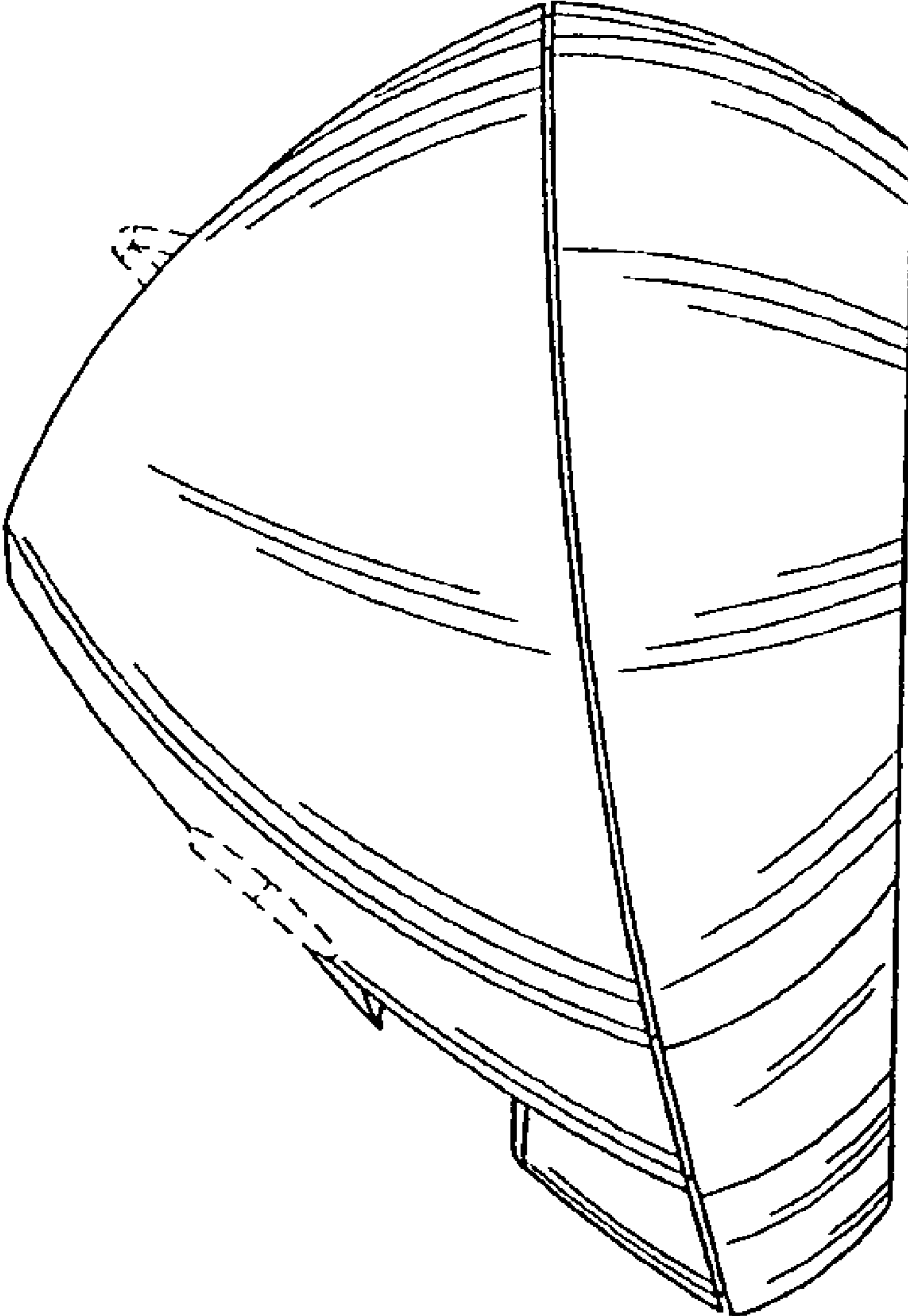
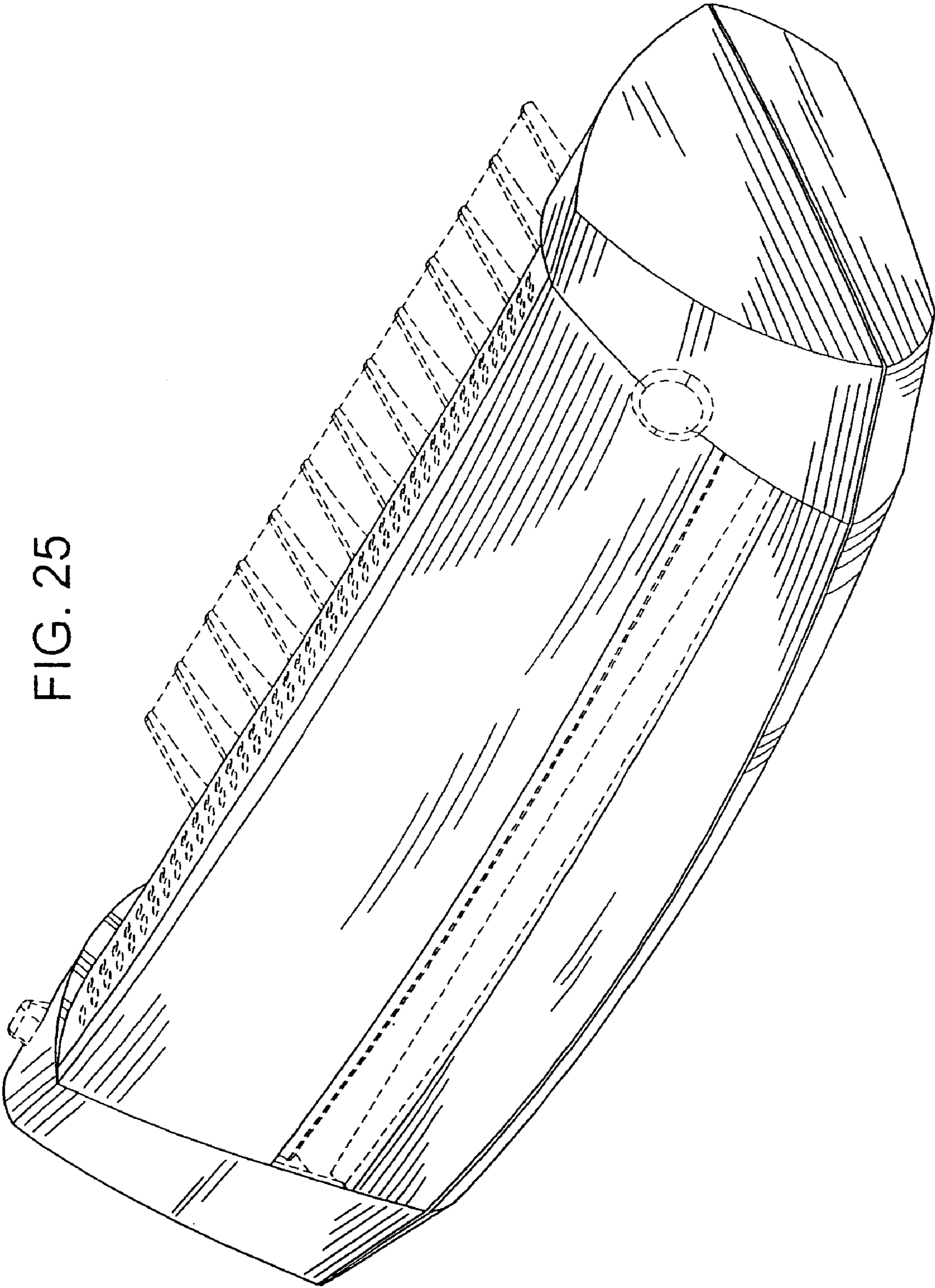

FIG. 25



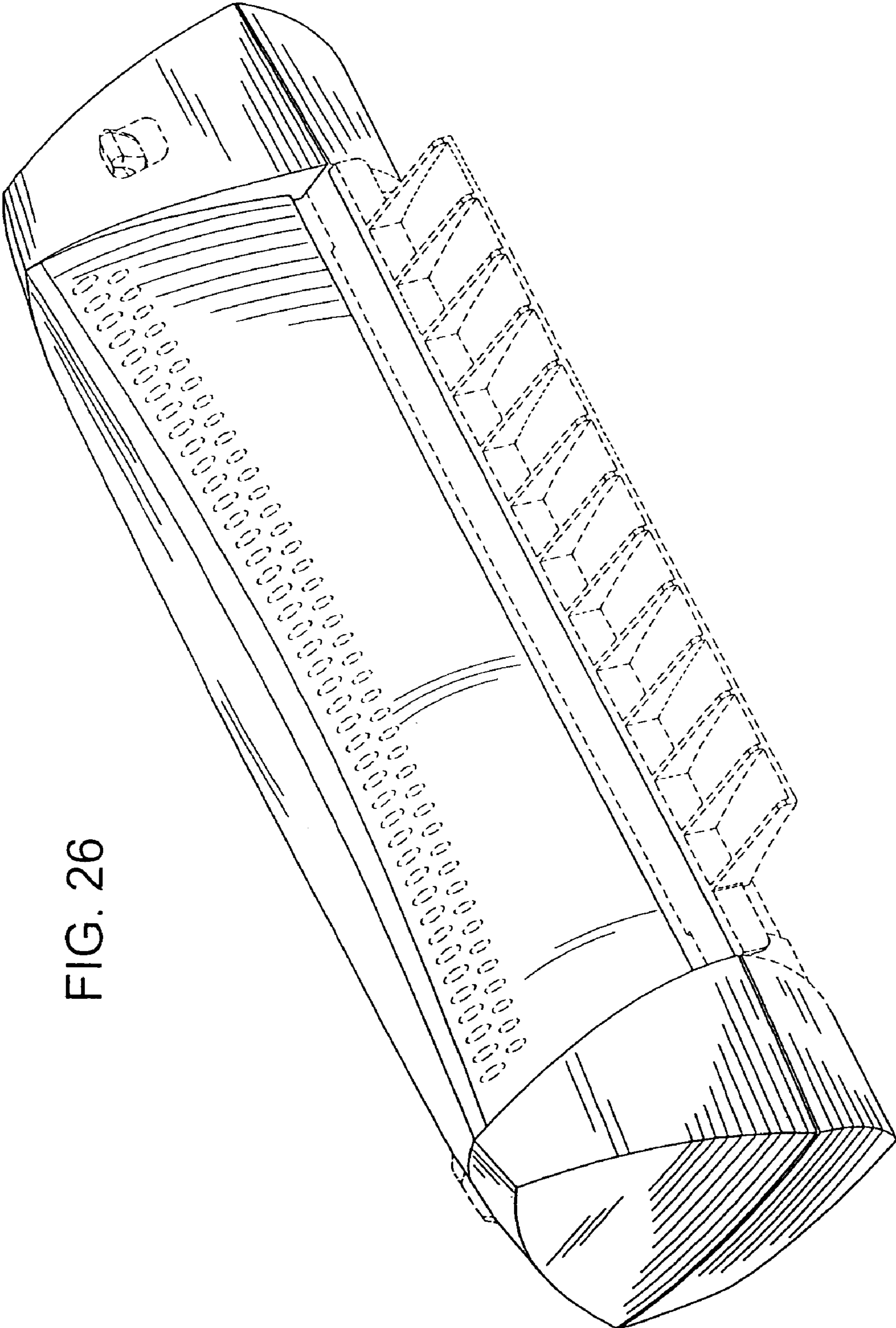

FIG. 26

FIG. 27

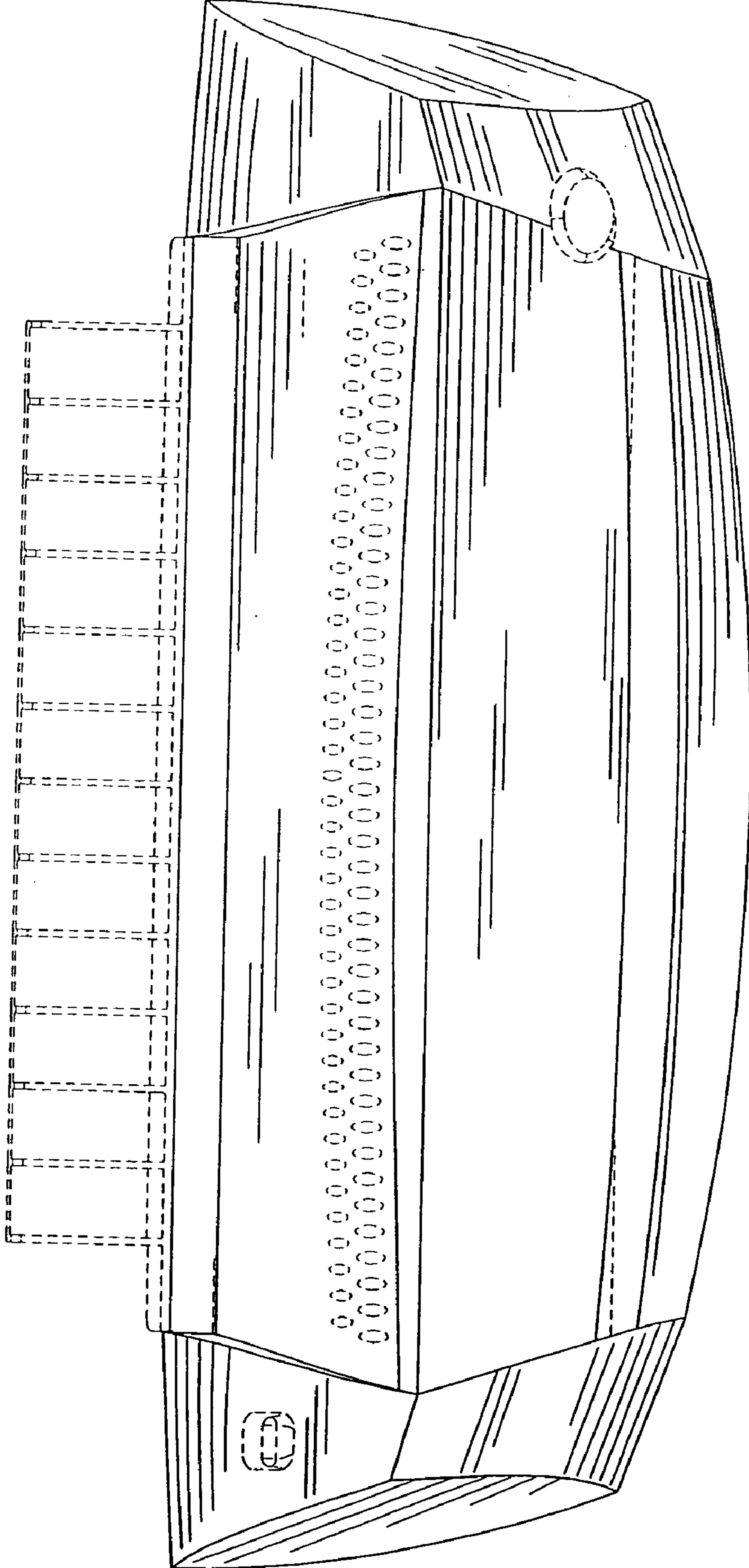

FIG. 28

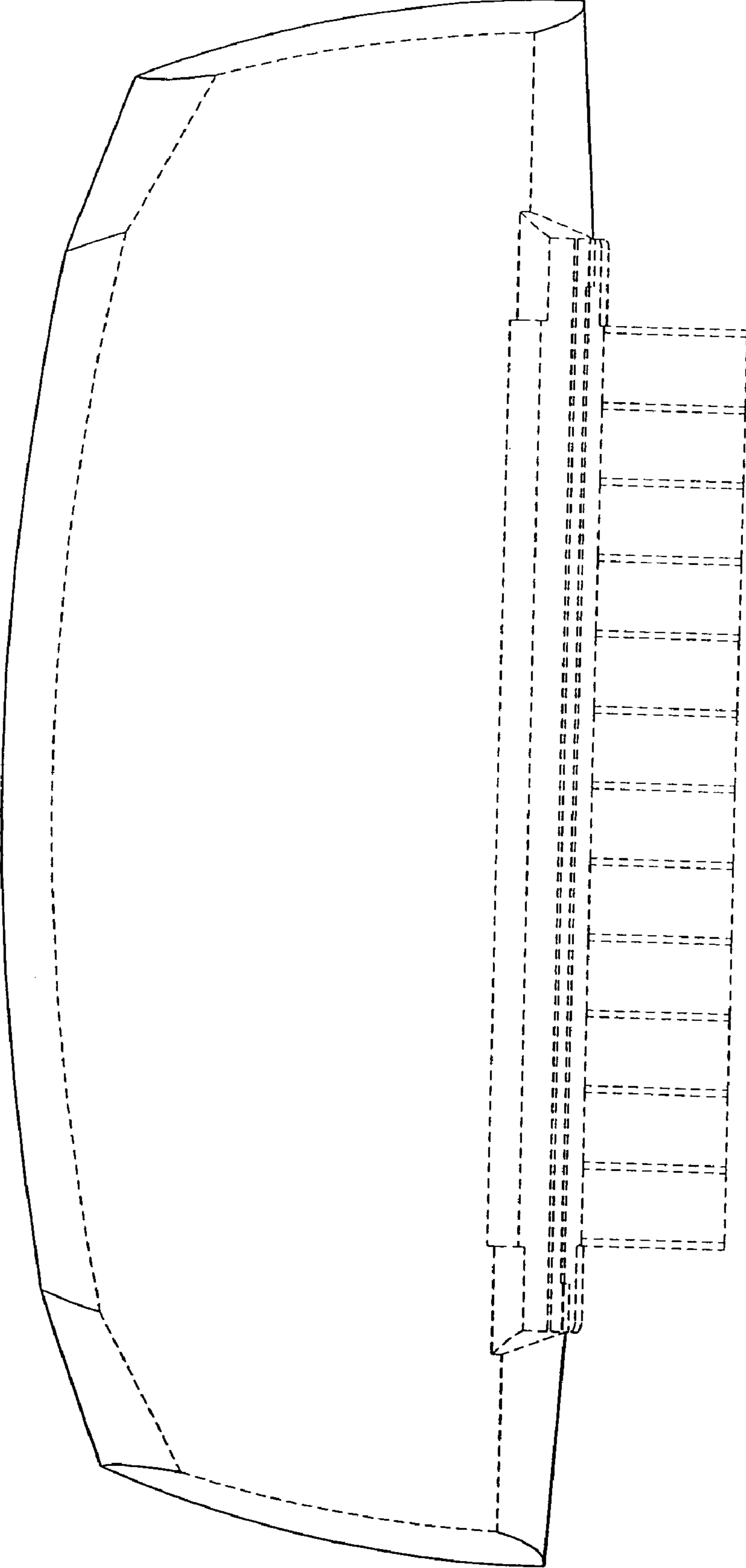

FIG. 29

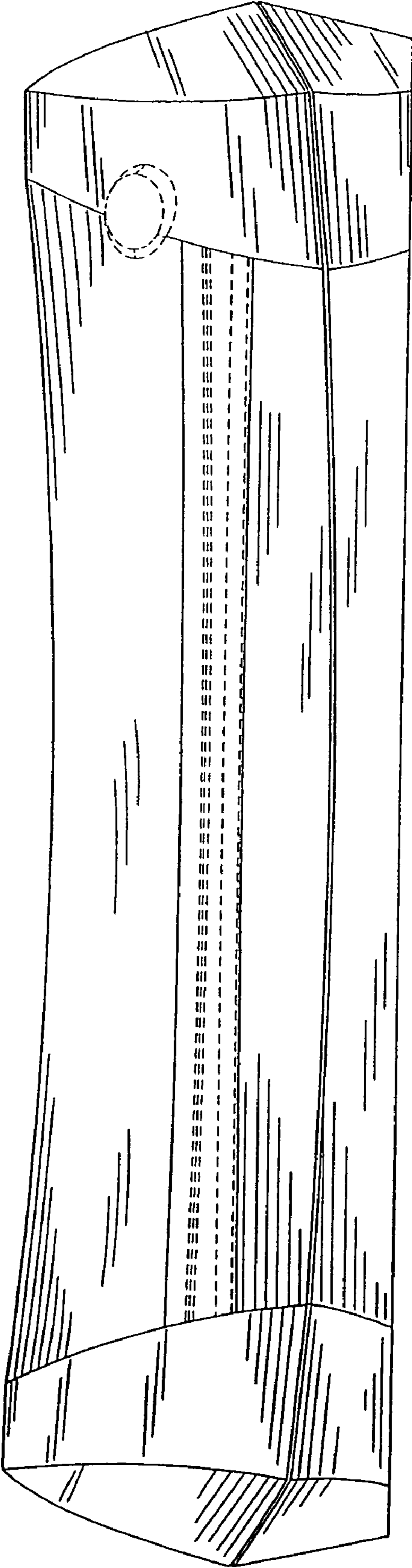

FIG. 30

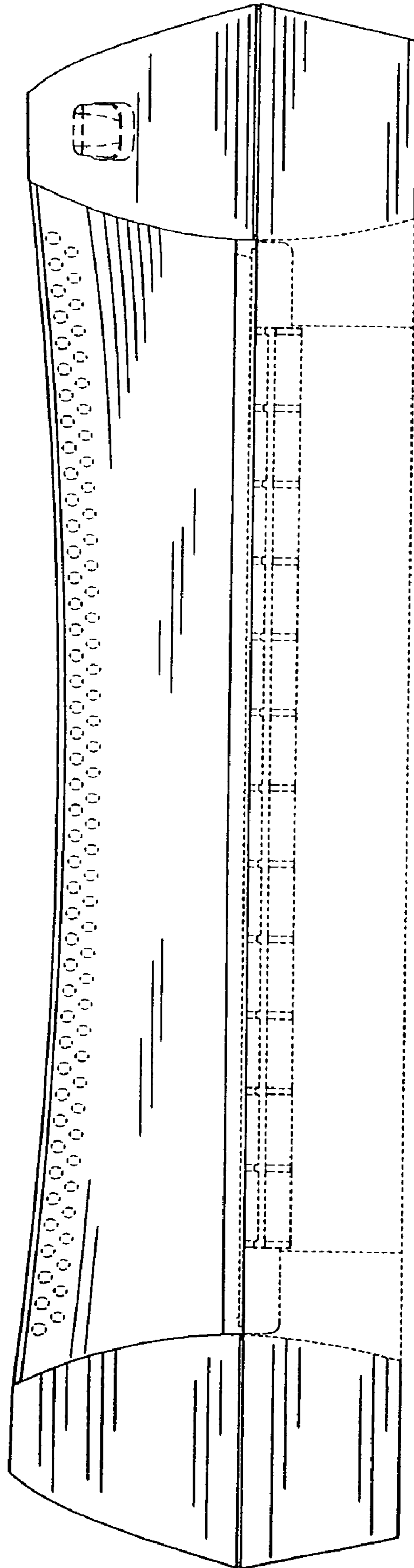

FIG. 31

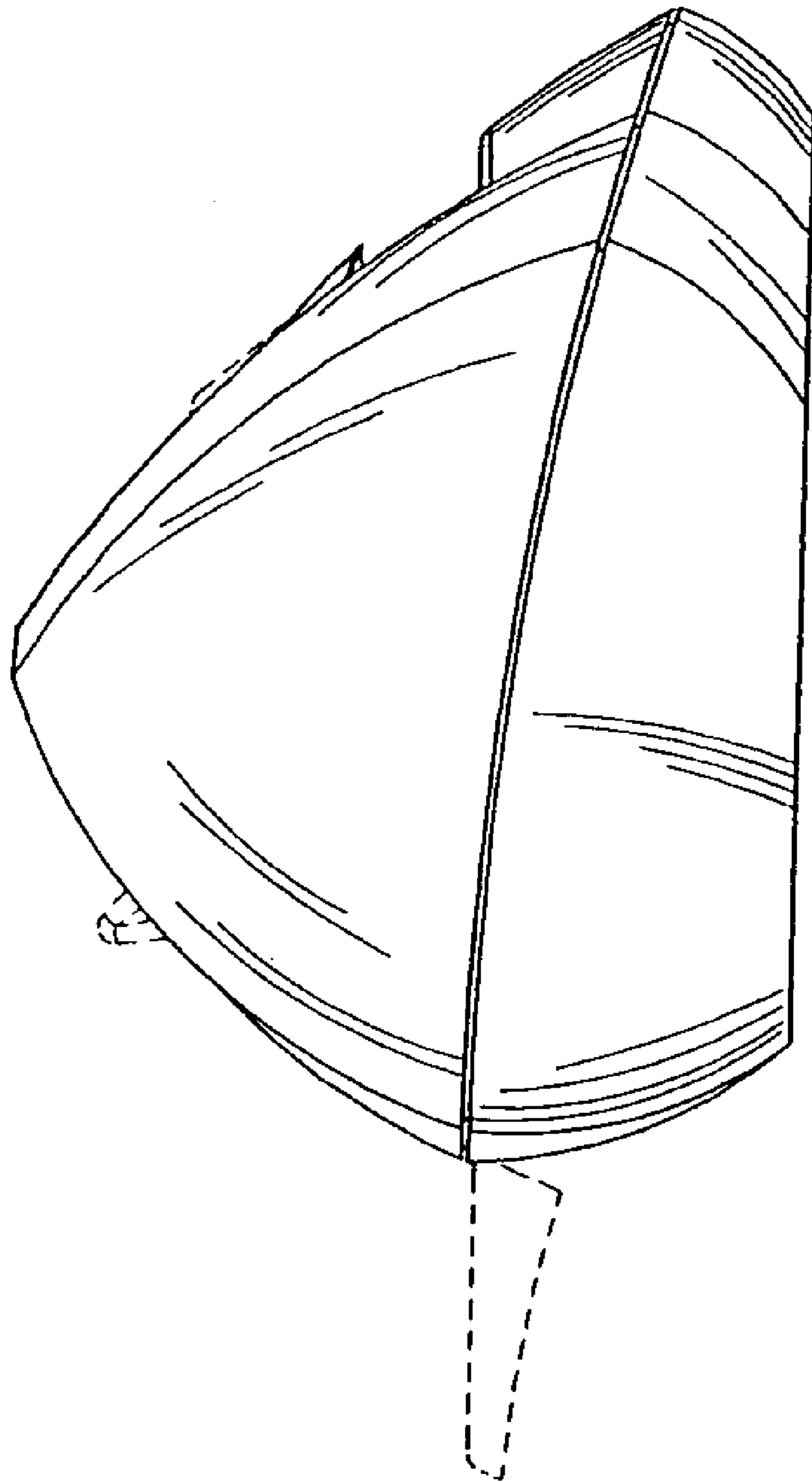

FIG. 32

