



US00D544441S

(12) **United States Design Patent**  
**Sichner et al.**

(10) **Patent No.: US D544,441 S**

(45) **Date of Patent: \*\* Jun. 12, 2007**

(54) **I/O MODULE**

(75) Inventors: **Gregg M. Sichner**, Mentor, OH (US);  
**Douglas A. Lostoski**, Richfield, OH  
(US); **Robert J. Hager**, Windsor, OH  
(US); **Robert A. Kozlowski**, Twinsburg,  
OH (US)

(73) Assignee: **Rockwell Automation Technologies,  
Inc.**, Mayfield Heights, OH (US)

(\*\*) Term: **14 Years**

(21) Appl. No.: **29/209,614**

(22) Filed: **Jul. 17, 2004**

**Related U.S. Application Data**

(63) Continuation-in-part of application No. 10/716,080, filed on  
Nov. 17, 2003, now Pat. No. 6,881,101, and a continuation-  
in-part of application No. 10/716,081, filed on Nov. 17,  
2003, now Pat. No. 6,916,194.

(51) **LOC (8) Cl.** ..... **13-03**

(52) **U.S. Cl.** ..... **D13/123; D13/146; D13/147**

(58) **Field of Classification Search** ..... D13/123,  
D13/133, 146-147, 151, 154, 184, 199; 439/271,  
439/281, 540.1, 594, 701, 717  
See application file for complete search history.

(56) **References Cited**

**U.S. PATENT DOCUMENTS**

D382,855 S \* 8/1997 Salmond et al. .... D13/139.8  
D397,088 S \* 8/1998 Heung et al. .... D13/139.6

6,081,048 A 6/2000 Bergmann et al.  
6,123,585 A 9/2000 Hussong et al.  
D443,248 S \* 6/2001 Sakasegawa ..... D13/123  
6,475,036 B2 11/2002 Morikawa  
6,527,599 B2 \* 3/2003 Bechtold et al. .... 439/736  
6,634,910 B2 10/2003 Lieb et al.  
D491,149 S \* 6/2004 Hoshino ..... D13/151  
6,802,737 B2 \* 10/2004 Bergner et al. .... 439/532  
6,860,757 B2 \* 3/2005 Herrnring et al. .... 439/535  
6,961,233 B2 \* 11/2005 Hoeing et al. .... 361/622  
7,021,974 B2 \* 4/2006 Sichner et al. .... 439/717

\* cited by examiner

*Primary Examiner*—Daniel Bui

(74) *Attorney, Agent, or Firm*—Steven M. Haas; R. Scott  
Speroff

(57) **CLAIM**

The ornamental design for an I/O module, as shown and  
described.

**DESCRIPTION**

FIG. 1 is a top, front and right side perspective view of an  
I/O module, showing our new design;  
FIG. 2 is a right side elevation view thereof;  
FIG. 3 is a bottom plan view thereof;  
FIG. 4 is a rear elevation view thereof;  
FIG. 5 is a left side elevation view thereof;  
FIG. 6 is a top plan view thereof; and,  
FIG. 7 is a front elevation view thereof.

The broken line showing of the environment is for illustra-  
tive purposes only and forms no part of the claimed design.

**1 Claim, 2 Drawing Sheets**

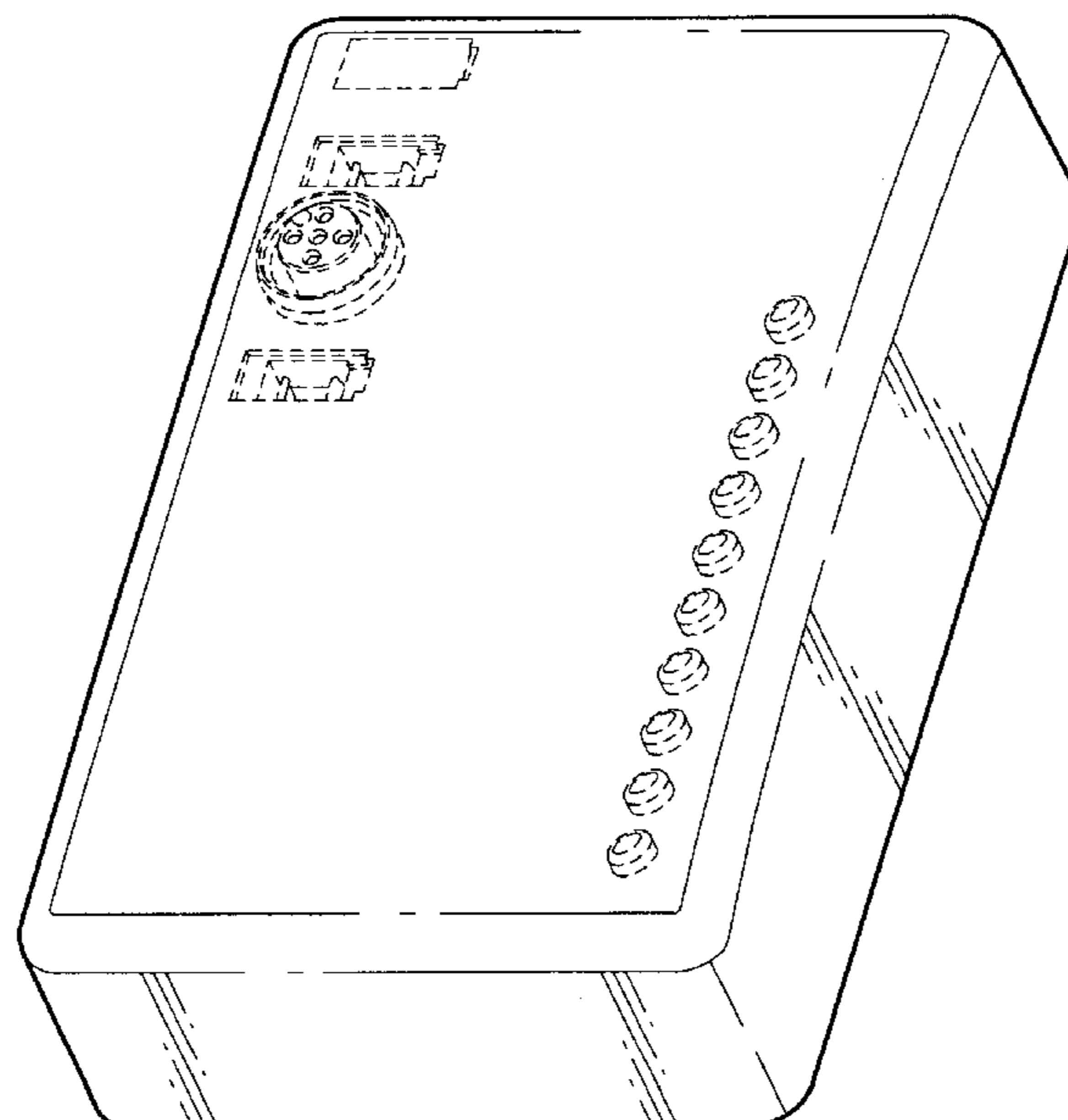

FIG. 1

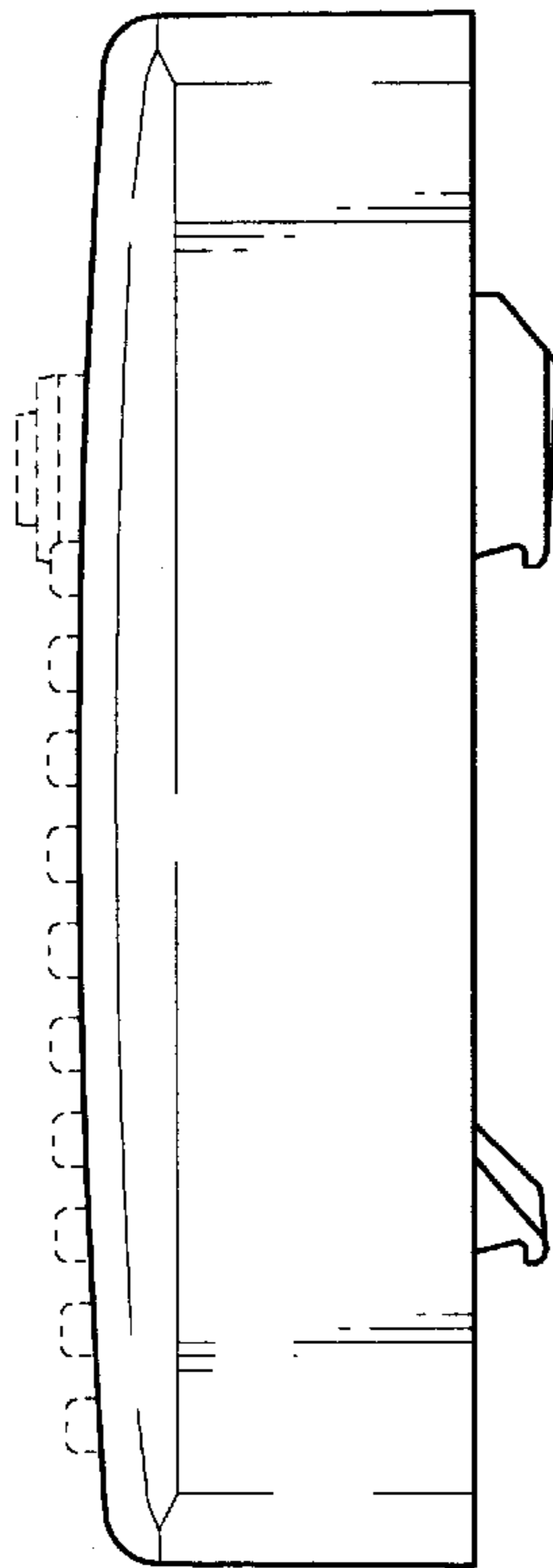
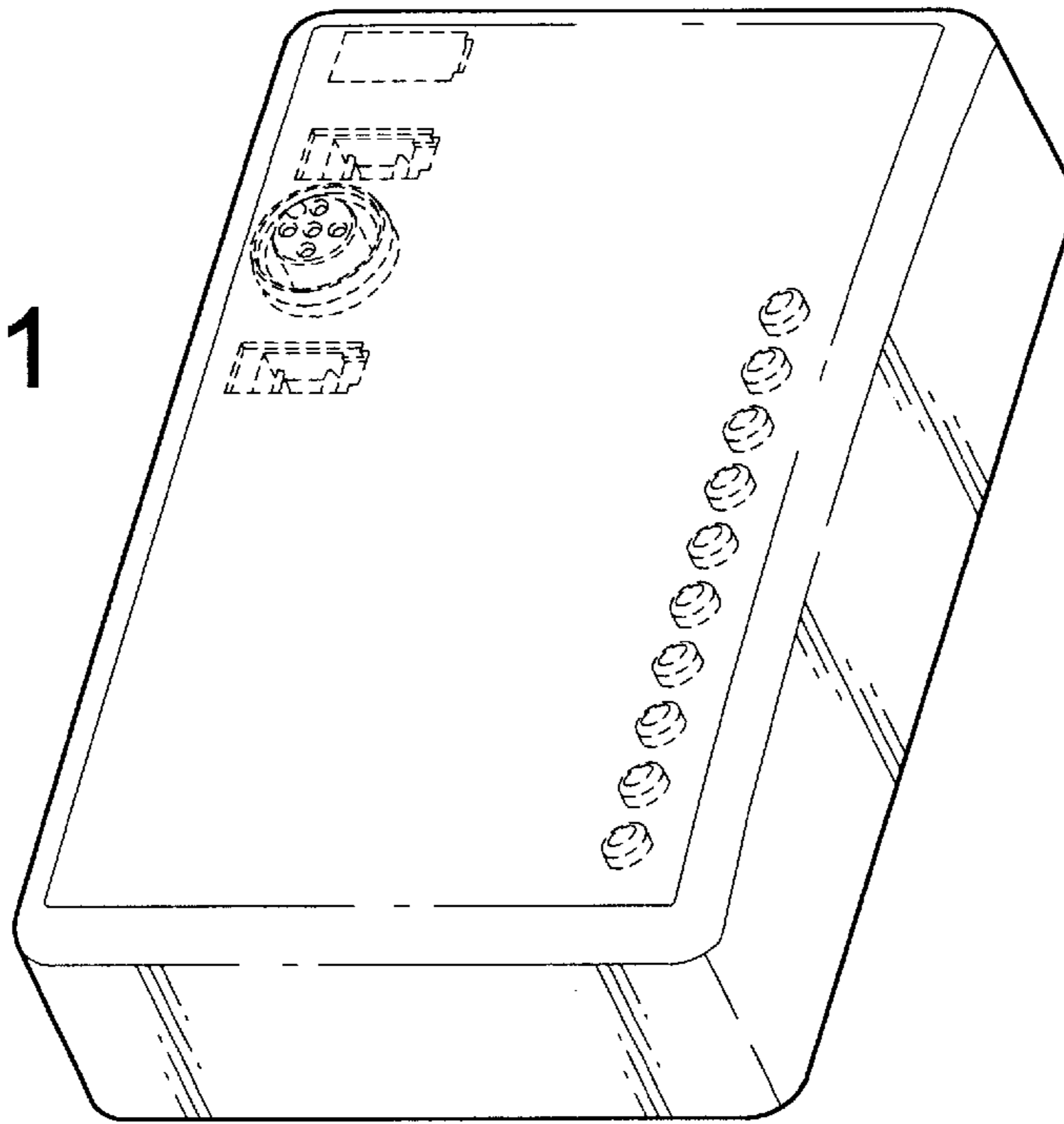

FIG. 2

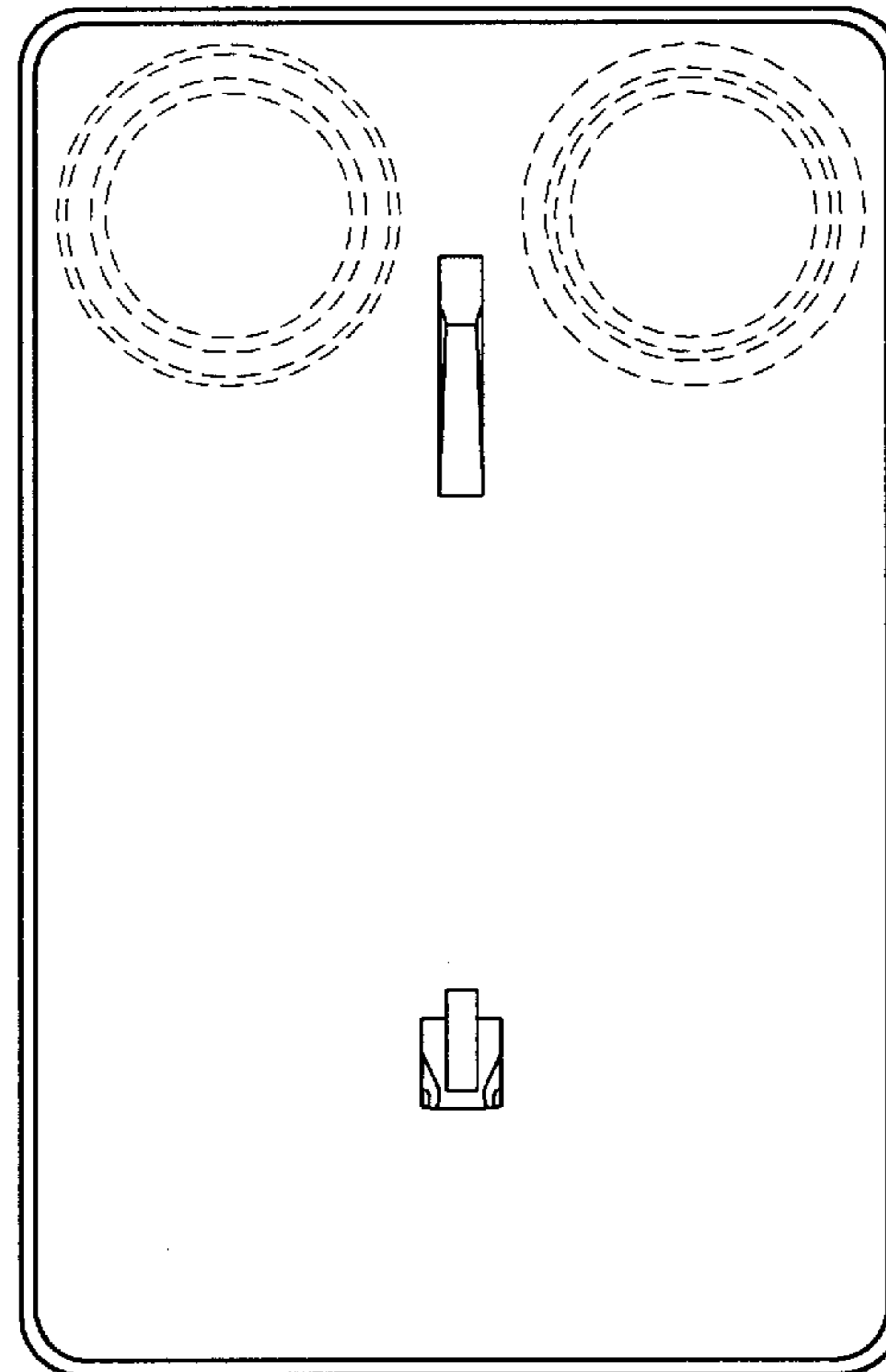

FIG. 3

FIG. 4

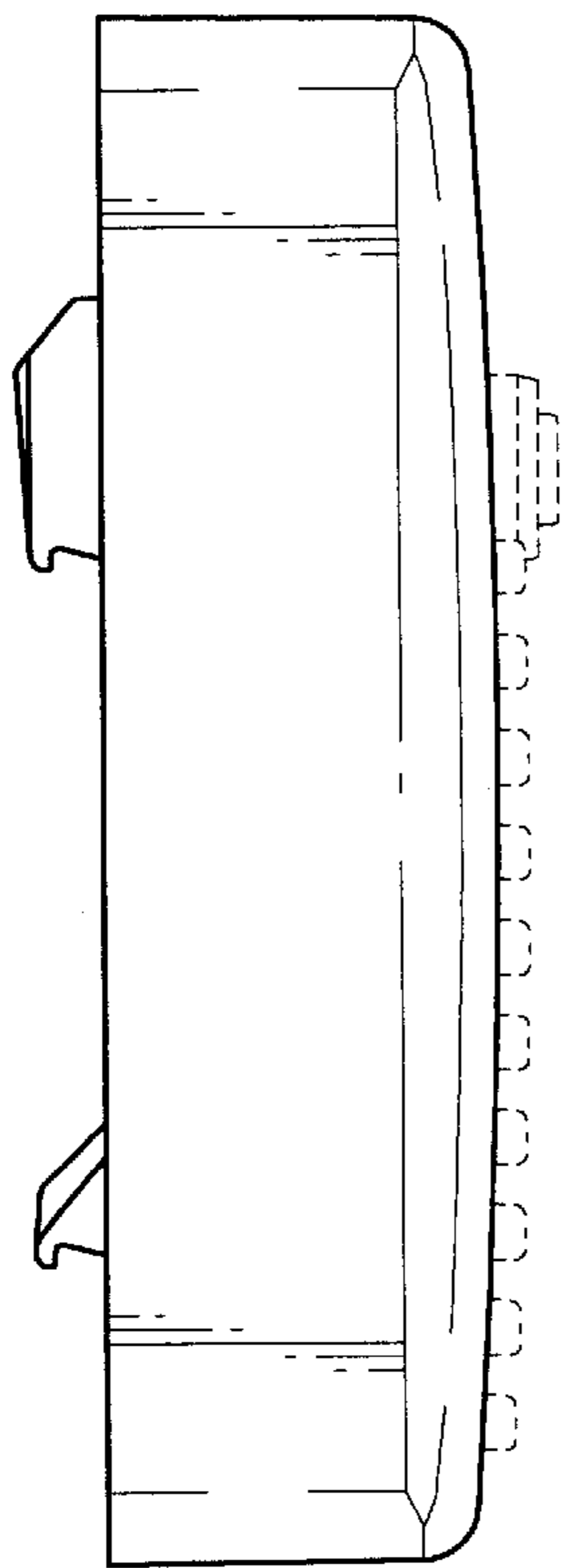
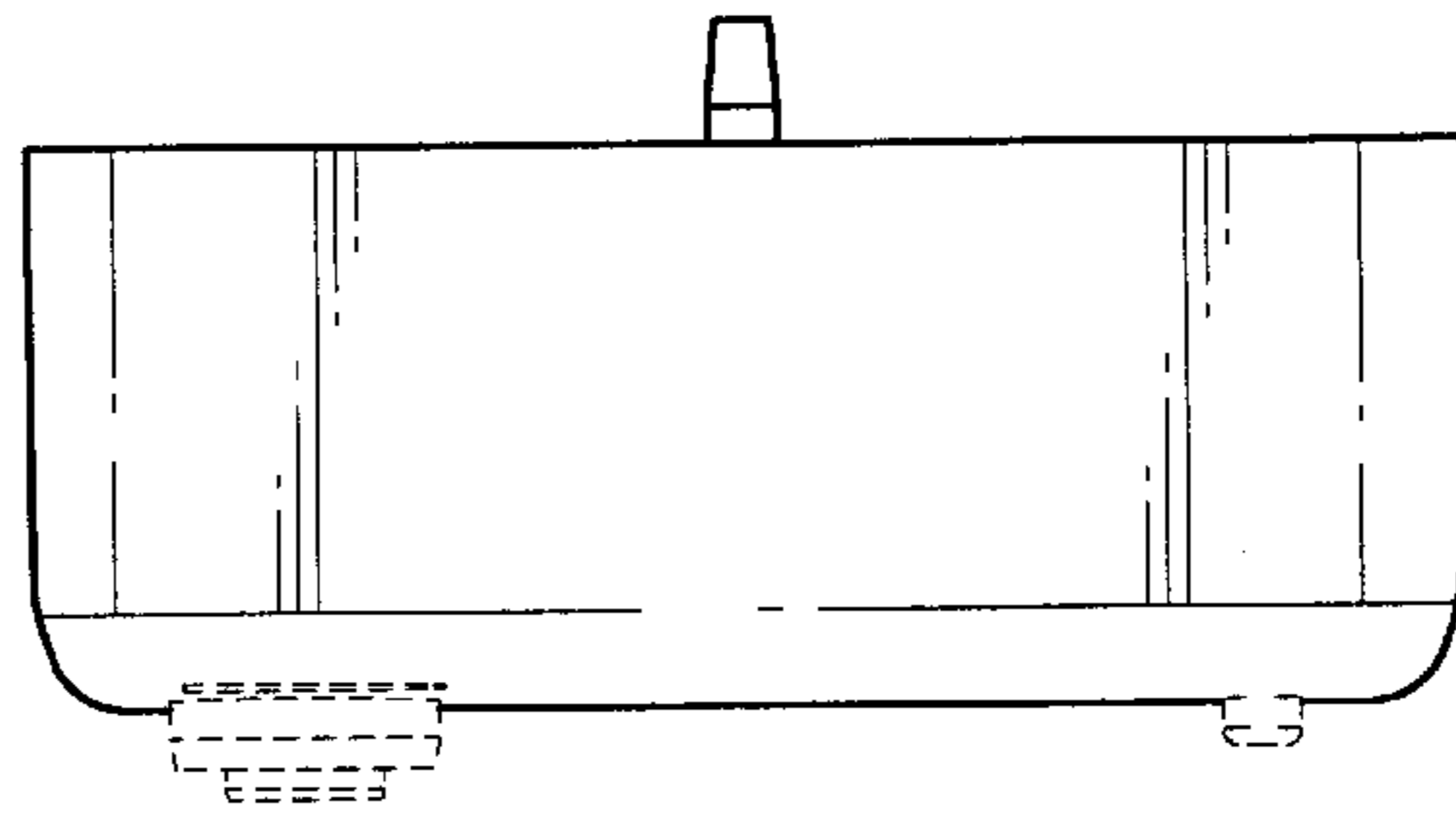

FIG. 5

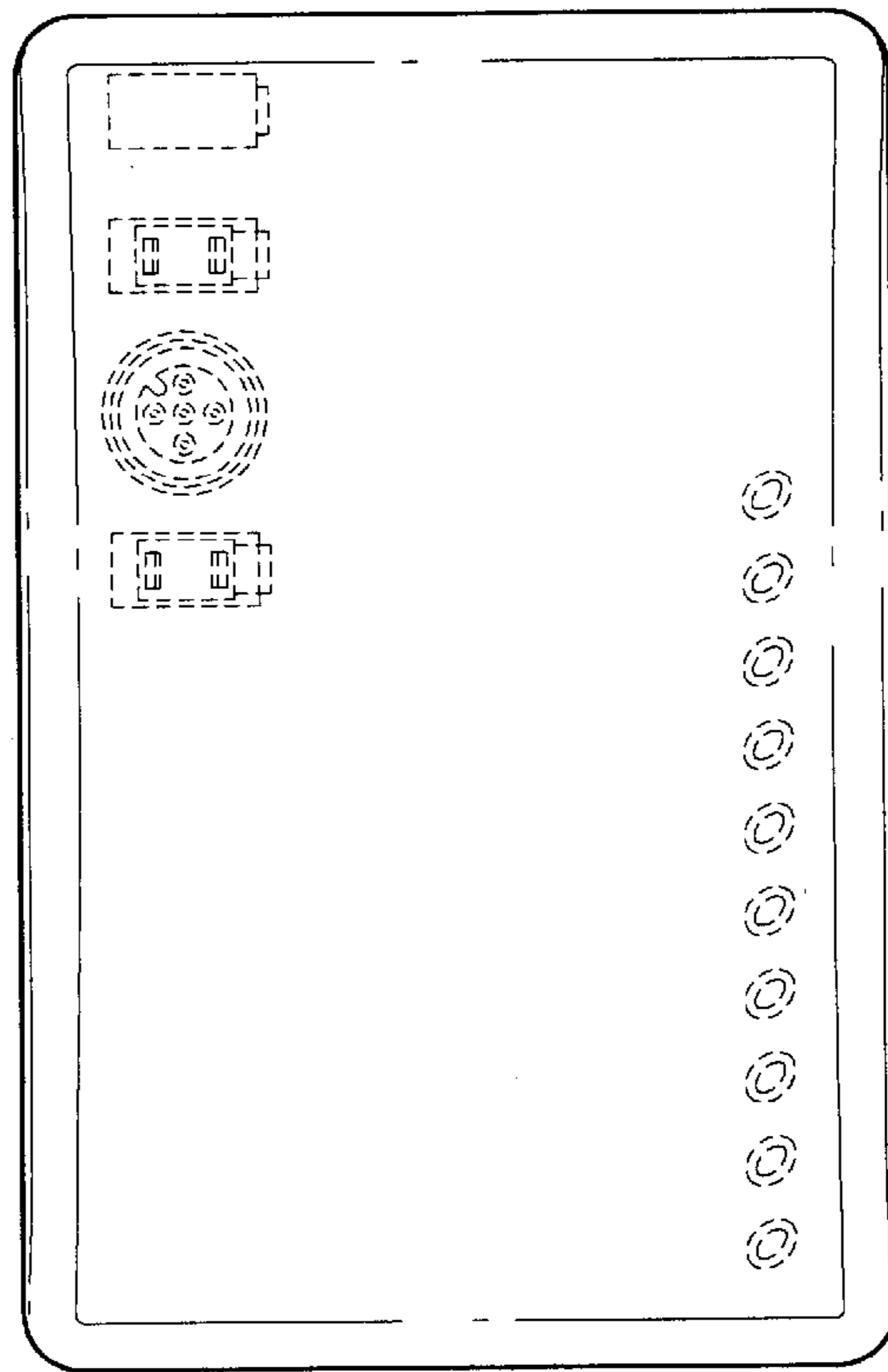

FIG. 6

FIG. 7

