

US00D544207S

(12) **United States Design Patent**
Lindars

(10) **Patent No.:** **US D544,207 S**
(45) **Date of Patent:** **** Jun. 12, 2007**

(54) **MULTI-CAP CARRIER**

6,510,972 B1 * 1/2003 Briskey 223/24
6,612,472 B1 * 9/2003 Zakarin 224/652

(75) Inventor: **James S. Lindars**, Huntington, VT
(US)

(73) Assignee: **New Era Cap Company, Inc.**, Buffalo,
NY (US)

(**) Term: **14 Years**

(21) Appl. No.: **29/244,784**

(22) Filed: **Dec. 14, 2005**

(51) **LOC (8) Cl.** **03-01**

(52) **U.S. Cl.** **D3/269; D3/289**

(58) **Field of Classification Search** D3/238,
D3/269, 273-274, 276, 289, 904; 150/107;
190/13 G, 103; 206/8, 278, 822; D9/414-415,
D9/428, 632

See application file for complete search history.

(56) **References Cited**

U.S. PATENT DOCUMENTS

D191,190 S *	8/1961	Noyes	D3/269
D205,909 S *	10/1966	Cline	D3/269
D293,391 S *	12/1987	Preston	D3/269
D308,602 S *	6/1990	St. Pierre	D3/269
5,022,515 A *	6/1991	Agostine	206/8
D344,233 S *	2/1994	Peters	D9/415
D346,491 S *	5/1994	Shoaf	D3/269
D355,600 S *	2/1995	Ford	D9/415
D363,620 S *	10/1995	Schweppe	D6/450
5,480,023 A *	1/1996	Puller	206/8
D378,732 S *	4/1997	Lawson	D9/632
D387,628 S *	12/1997	Keene	D7/607
5,950,895 A *	9/1999	Zakarin	224/645
6,125,997 A *	10/2000	Campbell	206/8
D469,010 S *	1/2003	Valdez et al.	D9/415

OTHER PUBLICATIONS

New Era Cap Carry Case. Downloaded Jan. 22, 2007 at <https://www.neweracap.co.uk/index.cfm?fuseaction=eShop.ItemDetail&selTeam=newera&selStyle=acc...> This reference not available as prior art. It is cited as general reference only and not as prior art.*
Capcase. Downloaded Jan. 21, 2007 at <http://www.capcase.com/Capcase.htm>.*

* cited by examiner

Primary Examiner—Philip S. Hyder
Assistant Examiner—RoseLynne (Ulm) Cody
(74) *Attorney, Agent, or Firm*—Phillips Lytle LLP

(57) **CLAIM**

Applicant claims the ornamental design for a multi-cap carrier, as shown and described.

DESCRIPTION

FIG. 1 is a perspective view of the multi-cap carrier.

FIG. 2 is a top plan view of the multi-cap carrier shown in FIG. 1.

FIG. 3 is a left side elevation of the multi-cap carrier shown in FIG. 1.

FIG. 4 is a right side elevation of the multi-cap carrier shown in FIG. 1.

FIG. 5 is a front end elevation of the multi-cap carrier shown in FIG. 1.

FIG. 6 is a rear end elevation of the multi-cap carrier shown in FIG. 1; and,

FIG. 7 is a bottom plan view of the multi-cap carrier shown in FIG. 1.

1 Claim, 4 Drawing Sheets

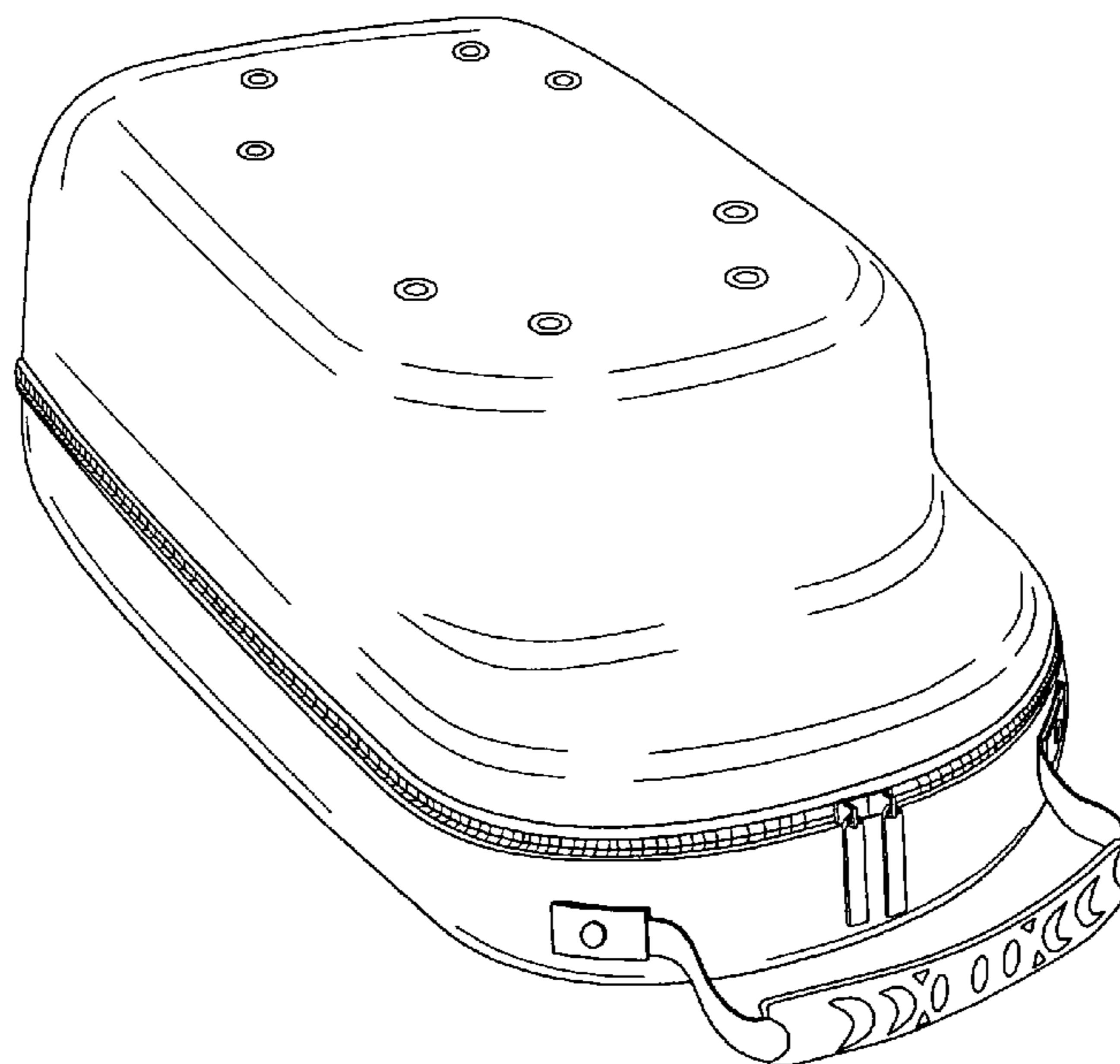

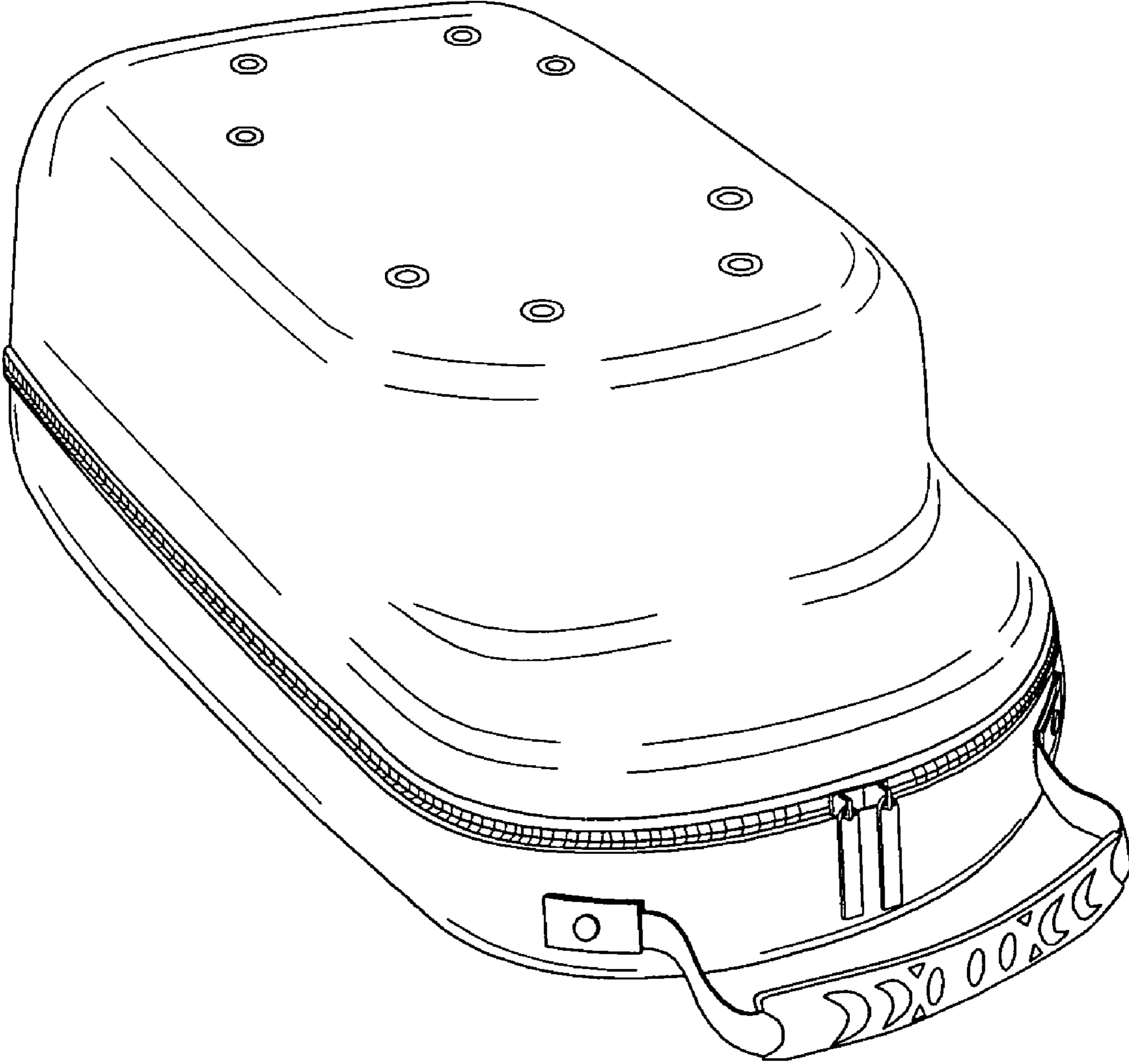

FIG. 1

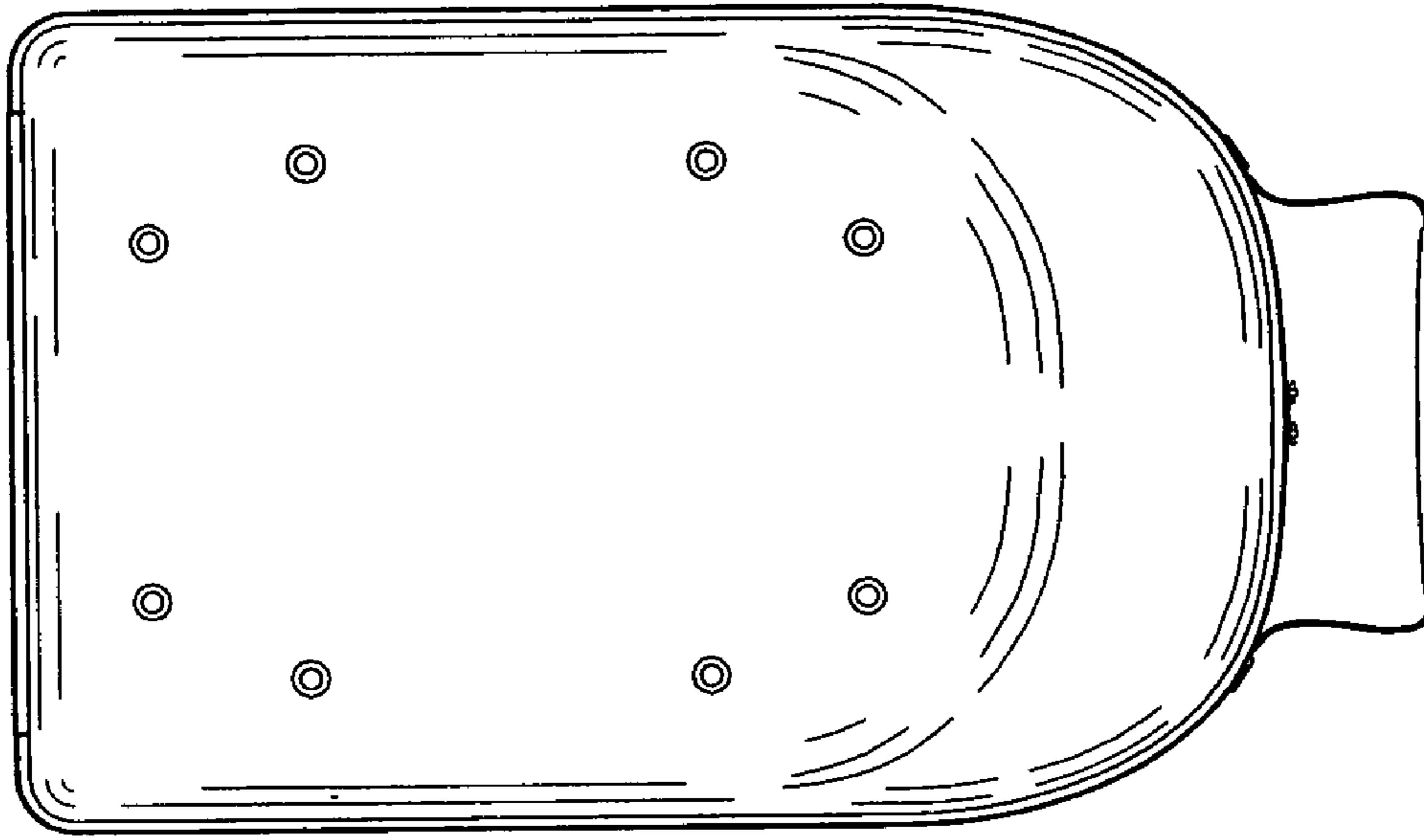

FIG. 2

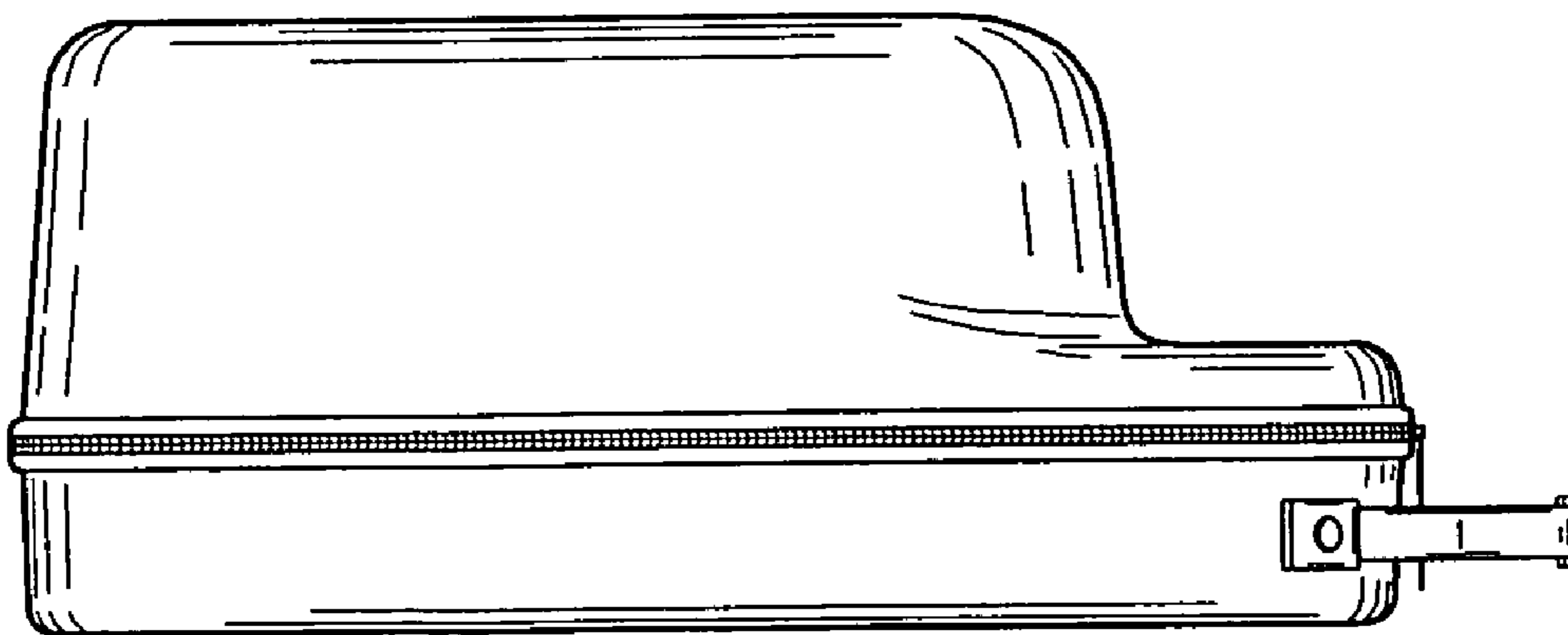

FIG. 3

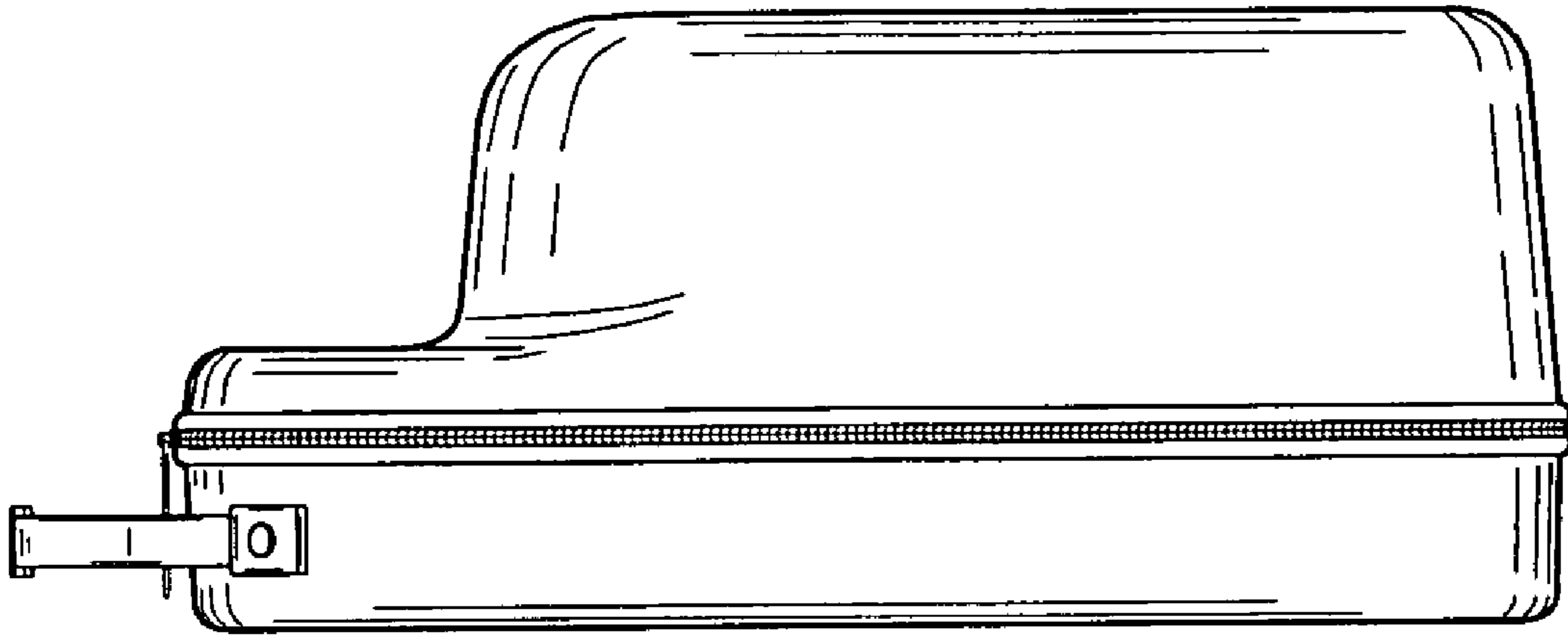

FIG. 4

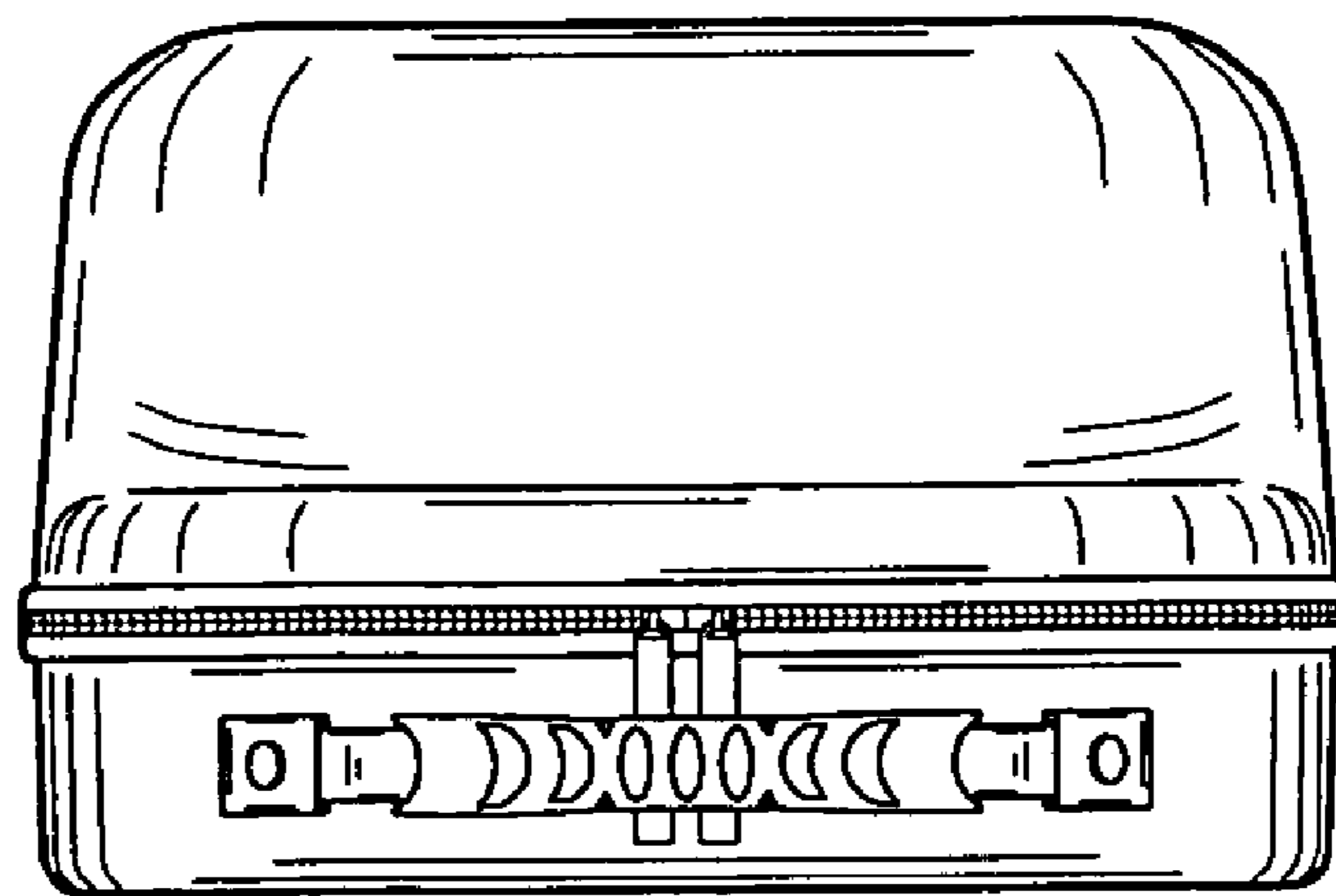

FIG. 5

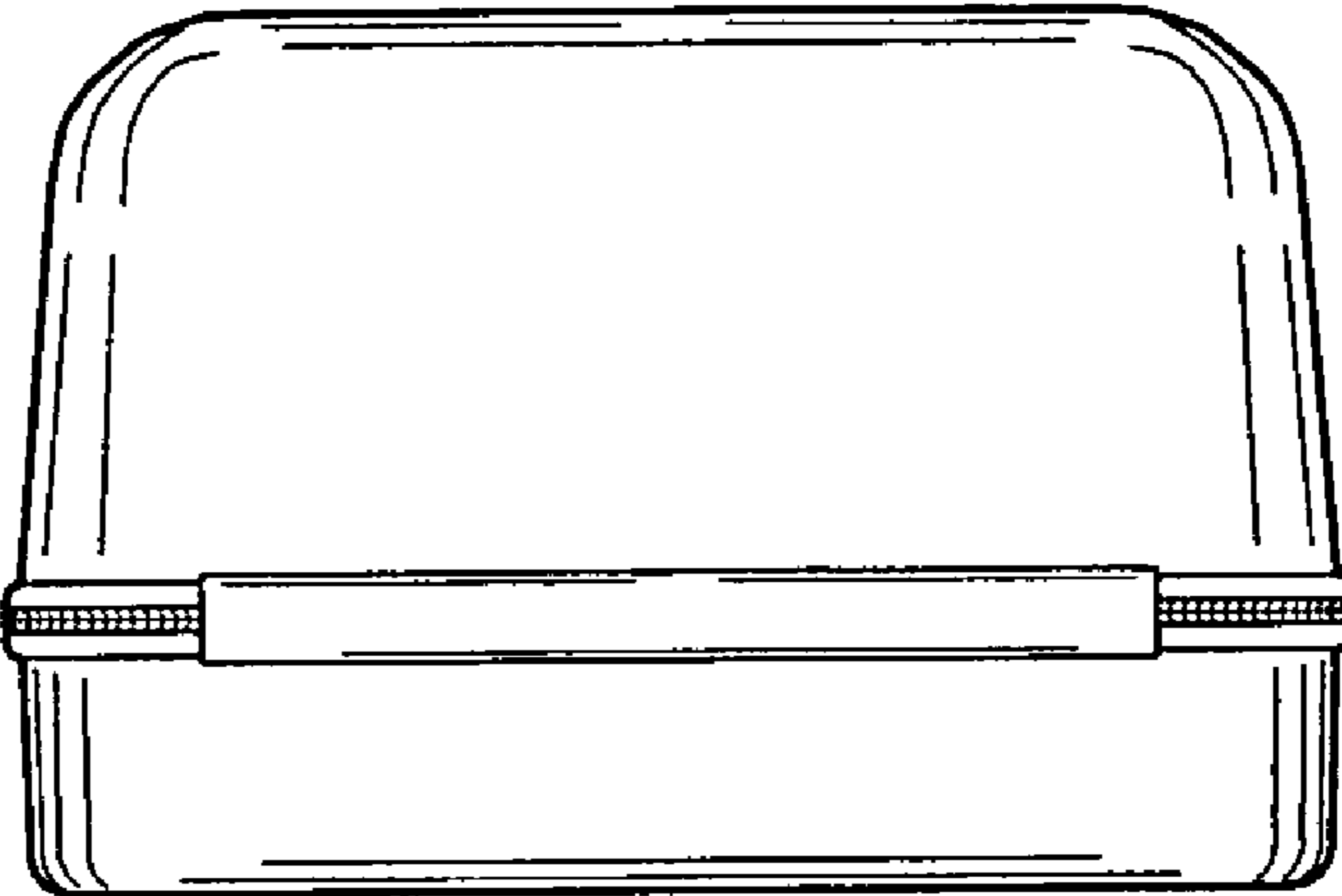

FIG. 6

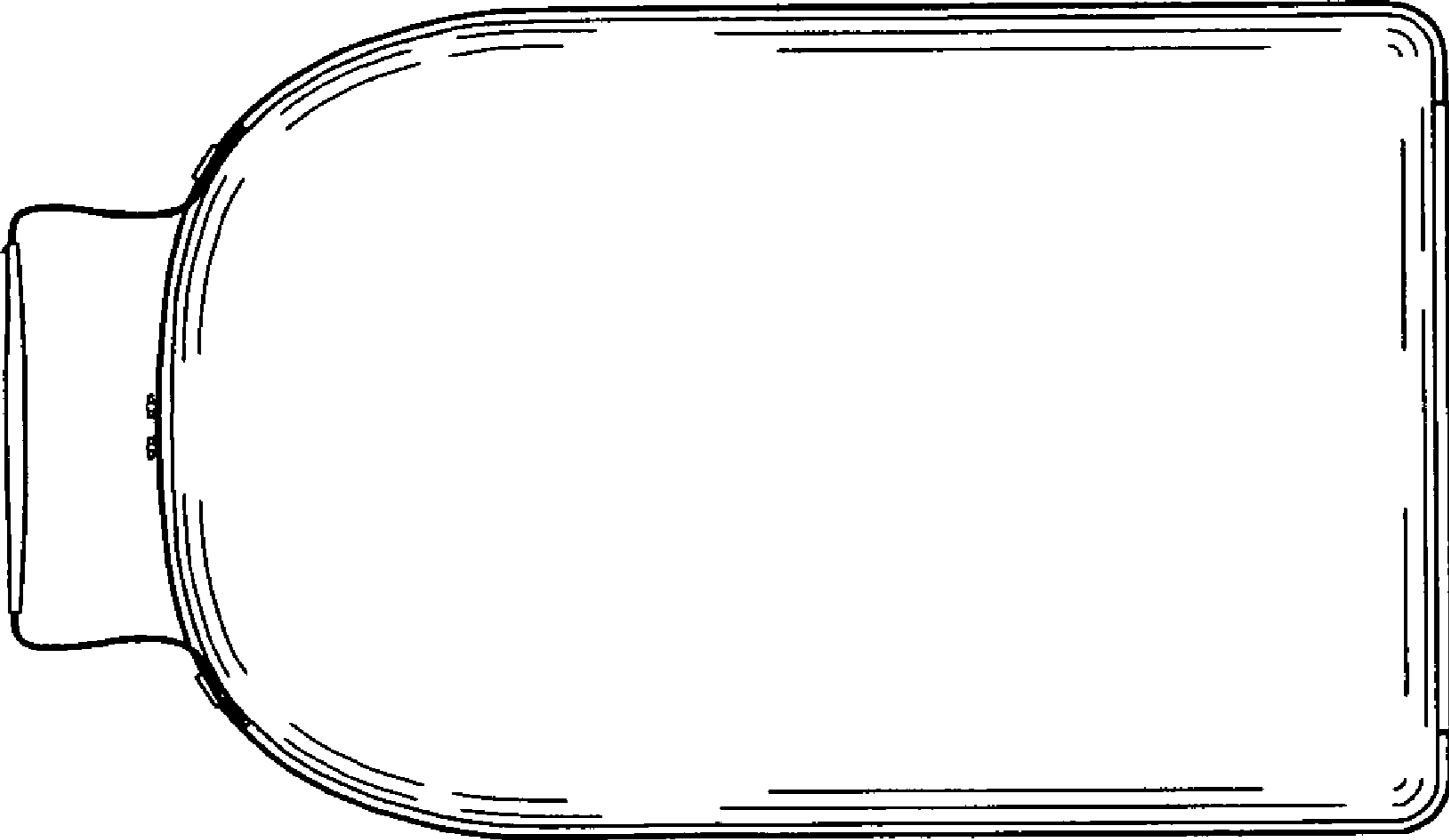

FIG. 7