



US00D544083S

(12) **United States Design Patent**
Walser

(10) **Patent No.:** **US D544,083 S**

(45) **Date of Patent:** **** Jun. 5, 2007**

(54) **MOTORCYCLE AIR FILTER ASSEMBLY**

(76) Inventor: **David Jerome Walser**, 41980 581st
Ave., New Ulm, MN (US) 56073

(**) Term: **14 Years**

(21) Appl. No.: **29/263,673**

(22) Filed: **Jul. 27, 2006**

(51) **LOC (8) Cl.** **23-04**

(52) **U.S. Cl.** **D23/365; D12/114; D12/126**

(58) **Field of Classification Search** D12/110,
D12/114, 126; D15/1-5; D23/364, 365;
180/219, 220; 123/195 C, 198 E, 389, 442;
55/385.3, 497, 498, 502, 510, DIG. 28; 261/23.2;
280/288.4

See application file for complete search history.

(56) **References Cited**

U.S. PATENT DOCUMENTS

4,592,316	A *	6/1986	Shiratsuchi et al.	123/195 C
D305,149	S	12/1989	Stahel	
D340,513	S	10/1993	Stahel, II et al.	
D384,141	S	9/1997	Goodson	
D420,943	S	2/2000	Netz et al.	
D426,494	S	6/2000	Wimmer	
D488,408	S	4/2004	Carli	
D489,651	S *	5/2004	Young	D12/126
D490,346	S *	5/2004	Young	D12/126

OTHER PUBLICATIONS

West Coast Choppers in the Year of Lord 2001 brochure, Iron Cross Air Cleaner, page unnumbered.*

J & P Cycles® 2003 Keeping the World on 2 Wheels® catalog, Forcewinder XR-2 Air Cleaner/Breather Kit and Forcewinder

Intake System for Big Twin & Sportster® at the top of p. 299 and Iron Cross Air Cleaner Insert by Ace Metal on p. 303.*

* cited by examiner

Primary Examiner—Alan P. Douglas

Assistant Examiner—Linda Brooks

(74) *Attorney, Agent, or Firm*—Hollingsworth & Funk, LLC

(57) **CLAIM**

The ornamental design for a motorcycle air filter assembly, substantially as shown and described.

DESCRIPTION

FIG. 1 is a perspective view of the top, front, and right side of the motorcycle air filter assembly;

FIG. 2 is a perspective view of the top, rear, and left side thereof;

FIG. 3 is a perspective view of the top, front, and left side of a second embodiment of a motorcycle air filter assembly as in FIG. 1, the only difference being the alternate end cap design;

FIG. 4 is a perspective view of the top, front, and right side of a third embodiment of a motorcycle air filter assembly as in FIG. 1, the only difference being yet another alternate end cap design;

FIG. 5 is a perspective, exploded view of the top, front, and left side of the motorcycle air filter assembly shown in FIG. 1; and,

FIG. 6 is a right side, exploded view of the motorcycle air filter assembly shown in FIG. 1.

1 Claim, 5 Drawing Sheets

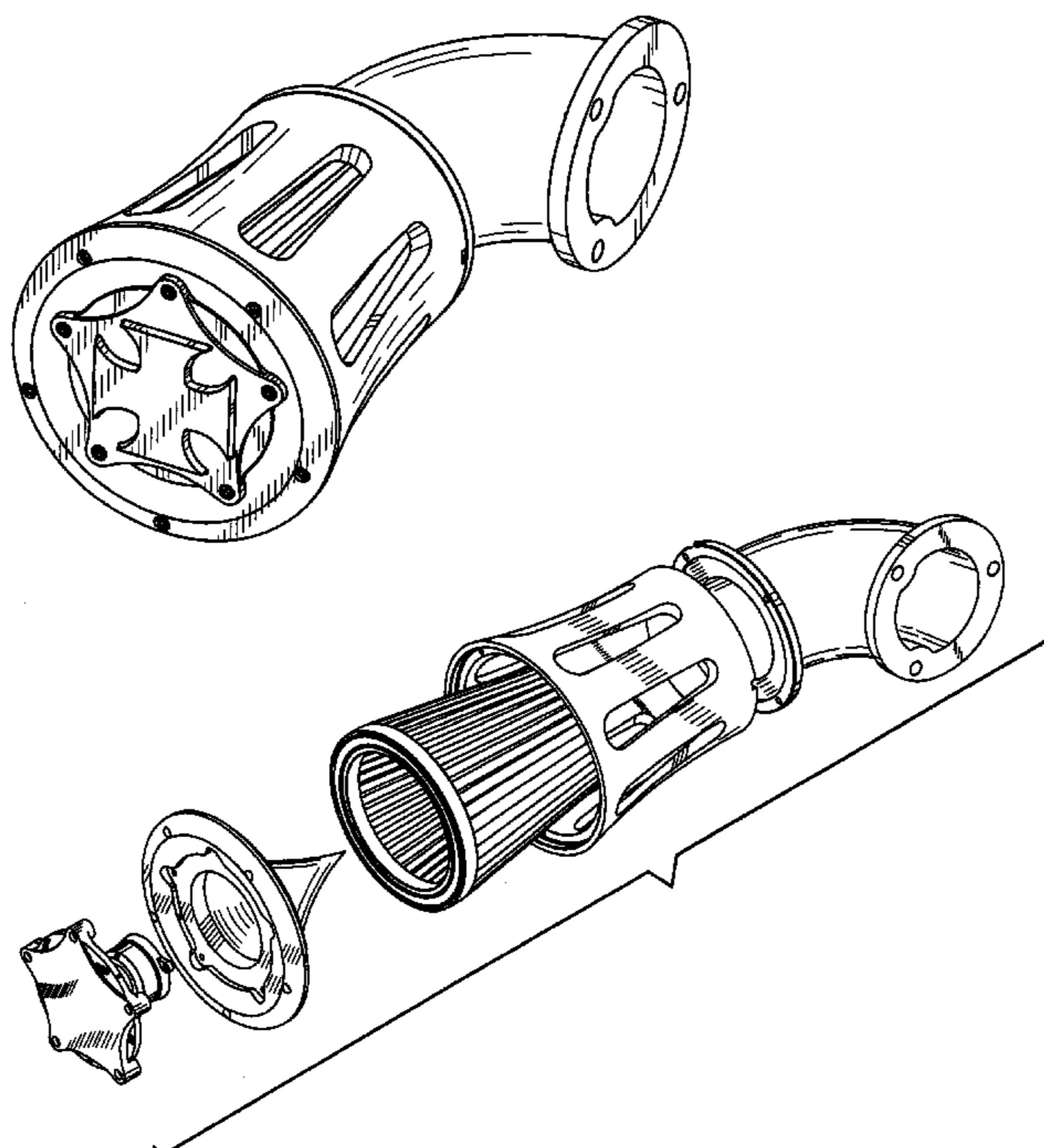

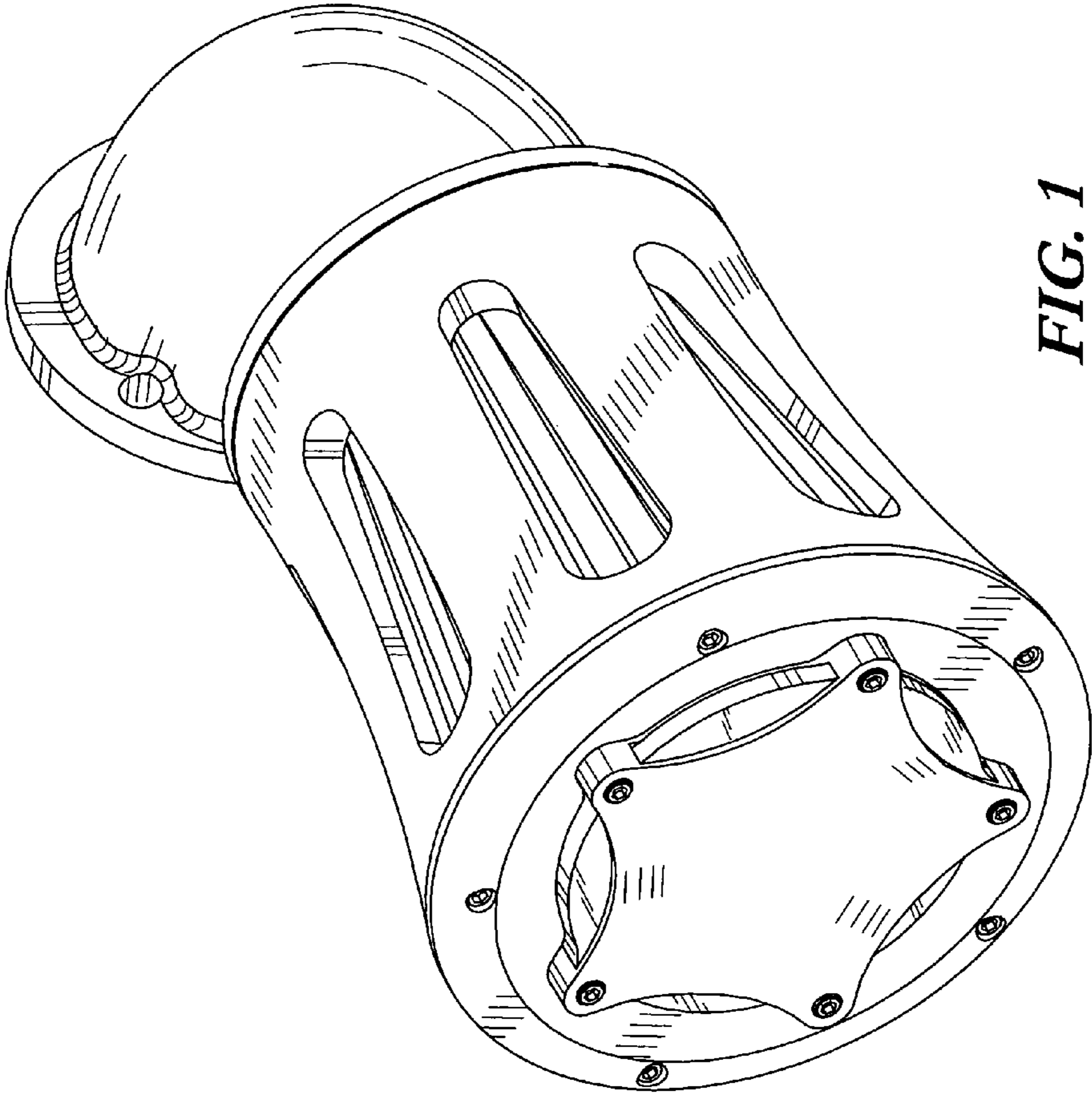

FIG. 1

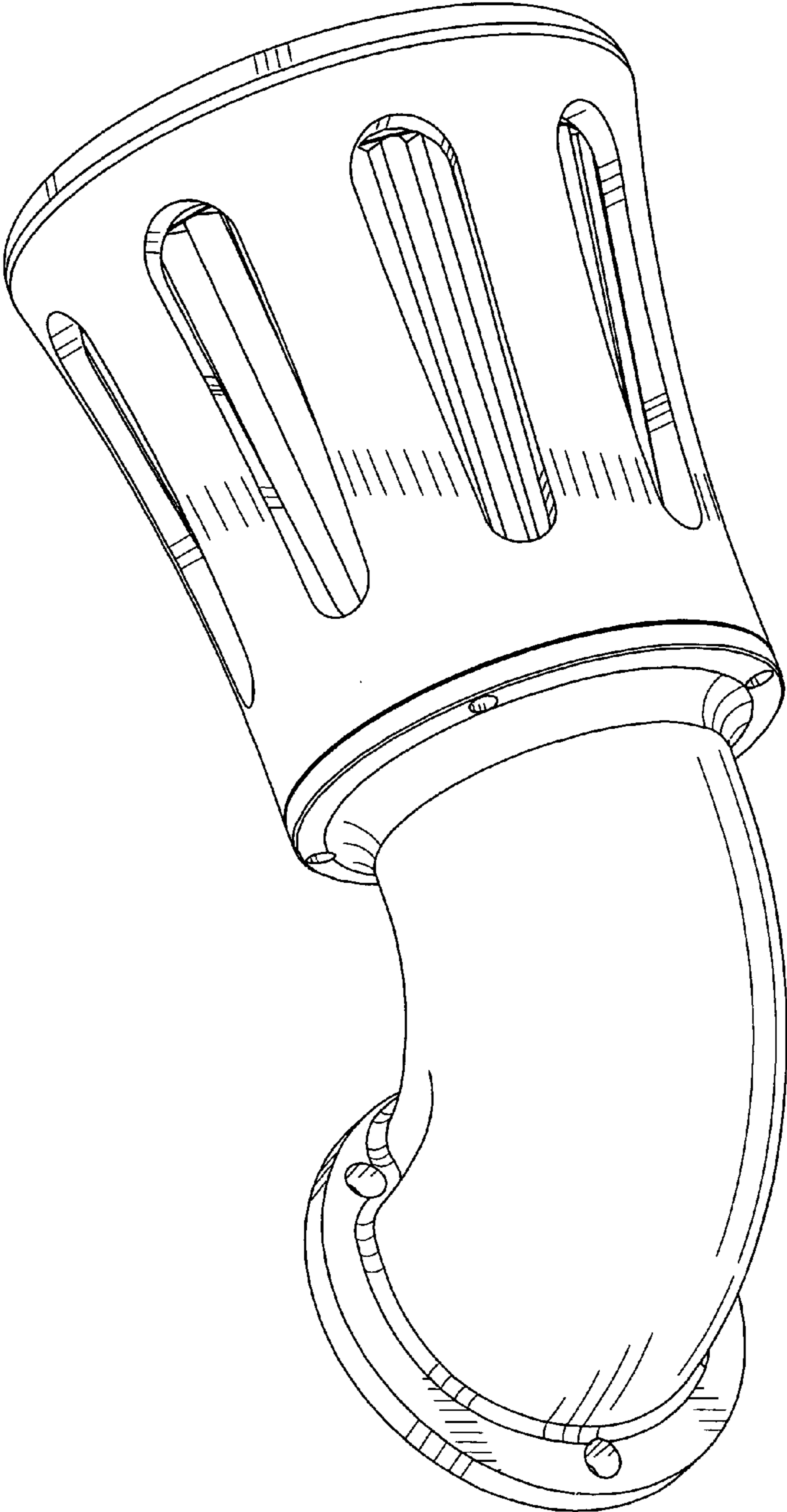

FIG. 2

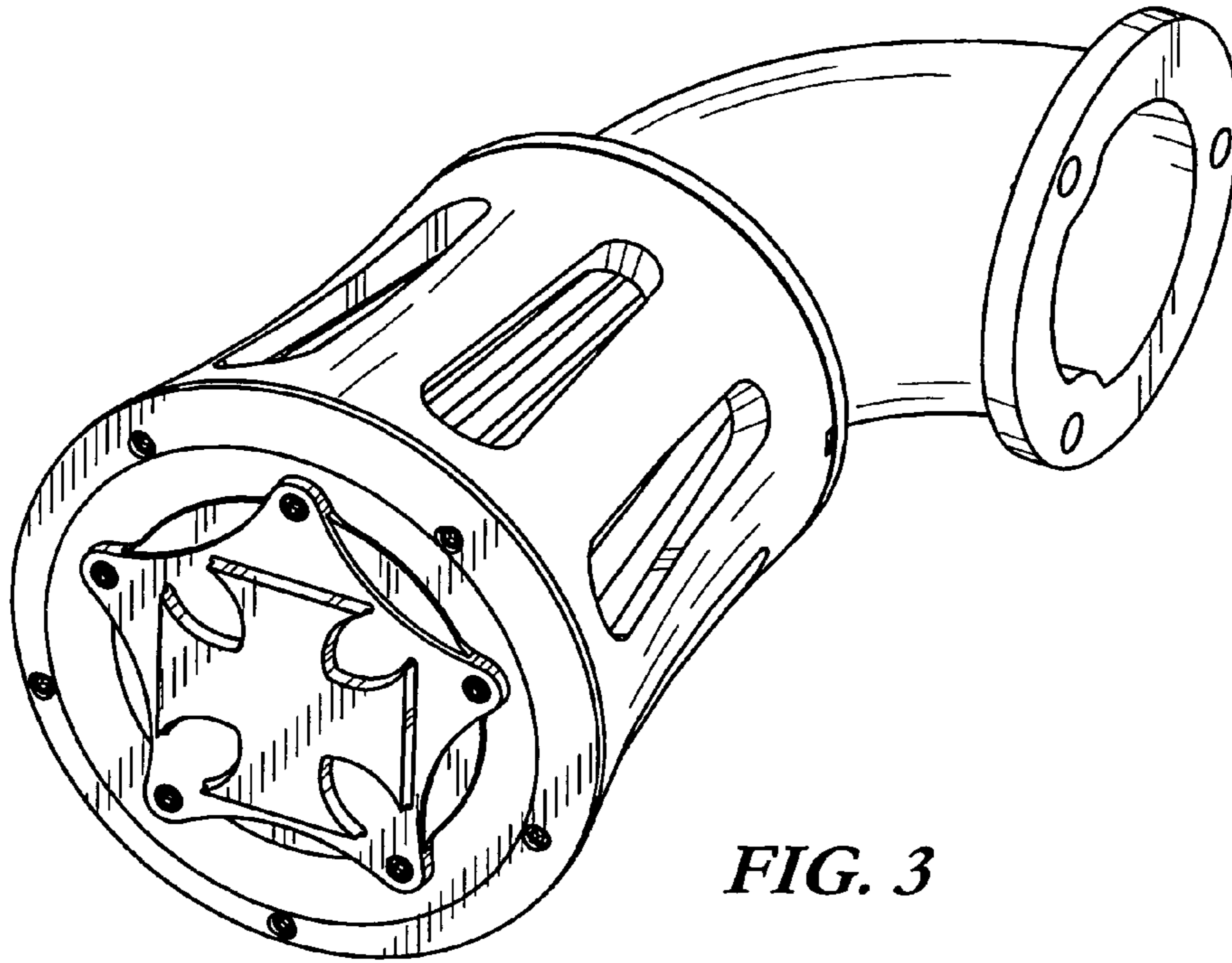

FIG. 3

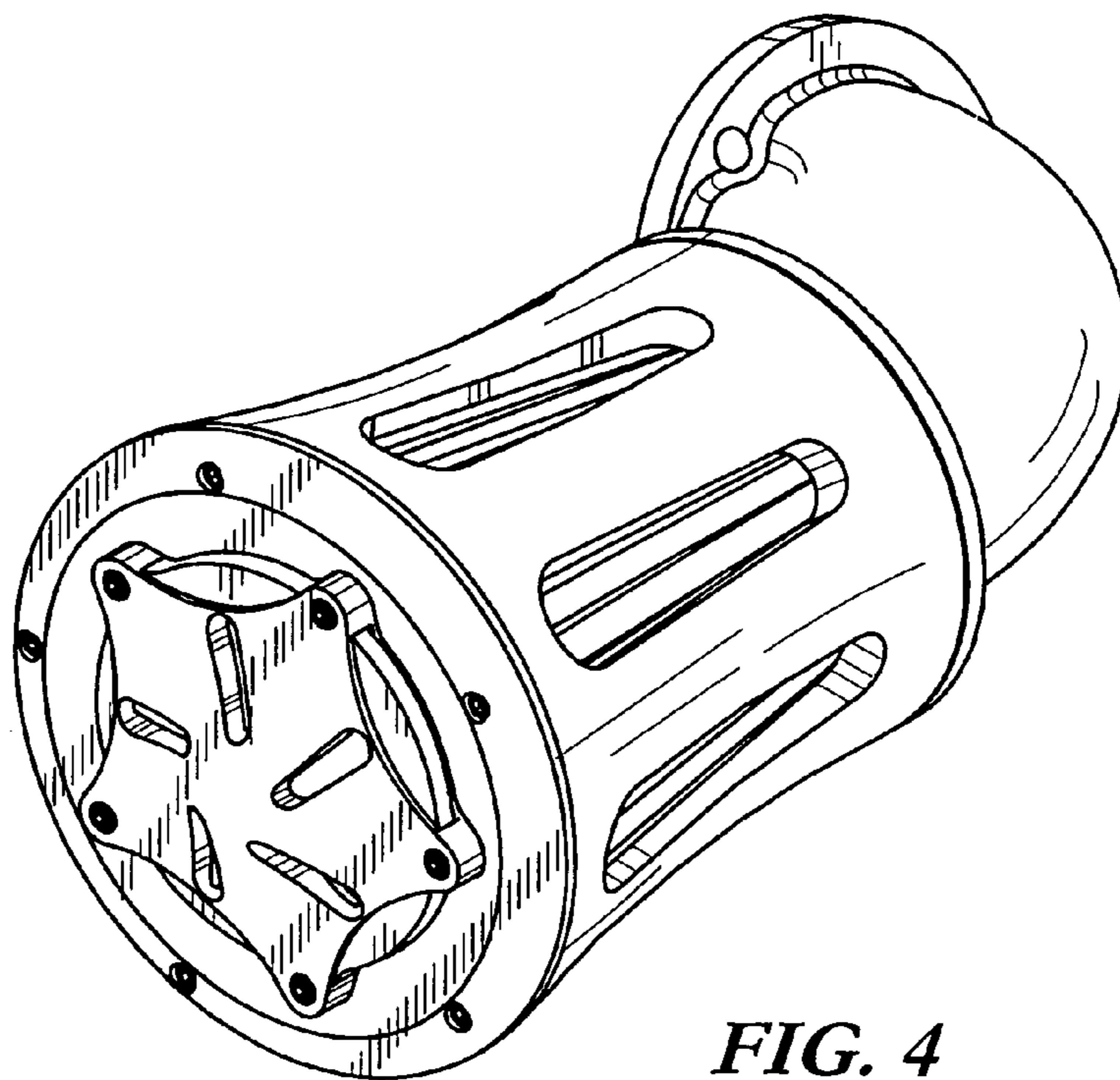

FIG. 4

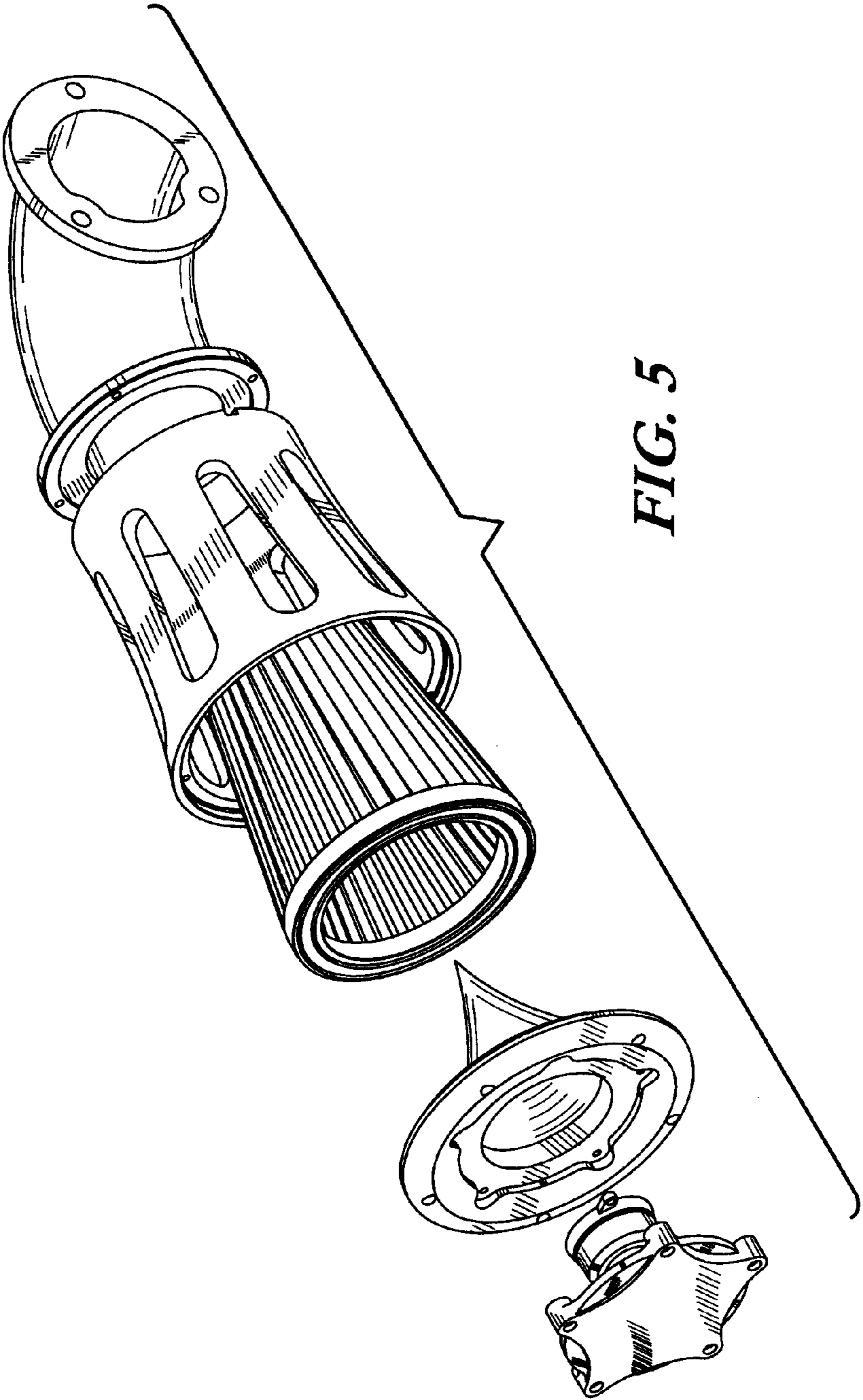

FIG. 5

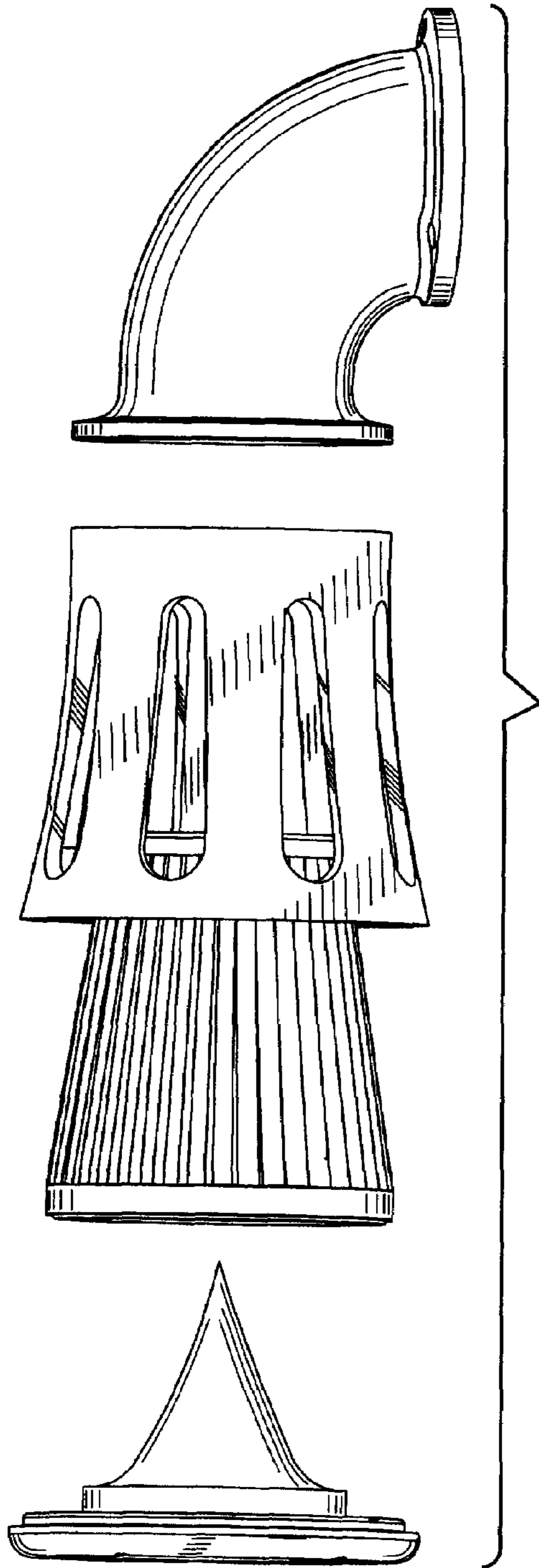

FIG. 6