

US00D543915S

(12) **United States Design Patent**
Fisker et al.

(10) **Patent No.:** **US D543,915 S**

(45) **Date of Patent:** **** Jun. 5, 2007**

(54) **COMBINED AUTOMOTIVE WINDOW AND PILLAR UNIT**

D528,052 S * 9/2006 Tserounian D12/182

(75) Inventors: **Henrik Fisker**, Newport Beach, CA (US); **John Paxton**, Long Beach, CA (US); **David Woodhouse**, Newport Coast, CA (US)

* cited by examiner

Primary Examiner—Melody N. Brown
(74) *Attorney, Agent, or Firm*—Frank A. McKenzie

(73) Assignee: **Ford Global Technologies, LLC**, Dearborn, MI (US)

(57) **CLAIM**

The ornamental design for a combined automotive window and pillar unit, as shown and described.

(**) Term: **14 Years**

DESCRIPTION

(21) Appl. No.: **29/220,950**

FIG. 1 is a right side/front end perspective view of a combined automotive window and pillar unit in accordance with the present invention, wherein a left side/front end perspective view is a mirror image thereof;

(22) Filed: **Jan. 7, 2005**

FIG. 2 is a left side perspective view of the combined automotive window and pillar unit of FIG. 1, wherein a right side perspective view is a mirror image thereof; and,

(51) **LOC (8) Cl.** **12-16**

(52) **U.S. Cl.** **D12/183**

(58) **Field of Classification Search** D12/182, D12/183; 296/84.1, 96.19, 96.21, 97.1, 97.2, 296/97.5, 95.1; 362/235-240, 307-311
See application file for complete search history.

FIG. 3 is a left side/rear end perspective view of the combined automotive window and pillar unit of Figure, wherein a right side/rear end perspective view is a mirror image thereof.

The broken lines are for illustrative purposes only and form no part of the claimed design.

(56) **References Cited**

U.S. PATENT DOCUMENTS

- D346,989 S * 5/1994 Dolan D12/91
- D457,844 S * 5/2002 Linson et al. D12/196
- D524,190 S * 7/2006 Fisker et al. D12/91

1 Claim, 3 Drawing Sheets

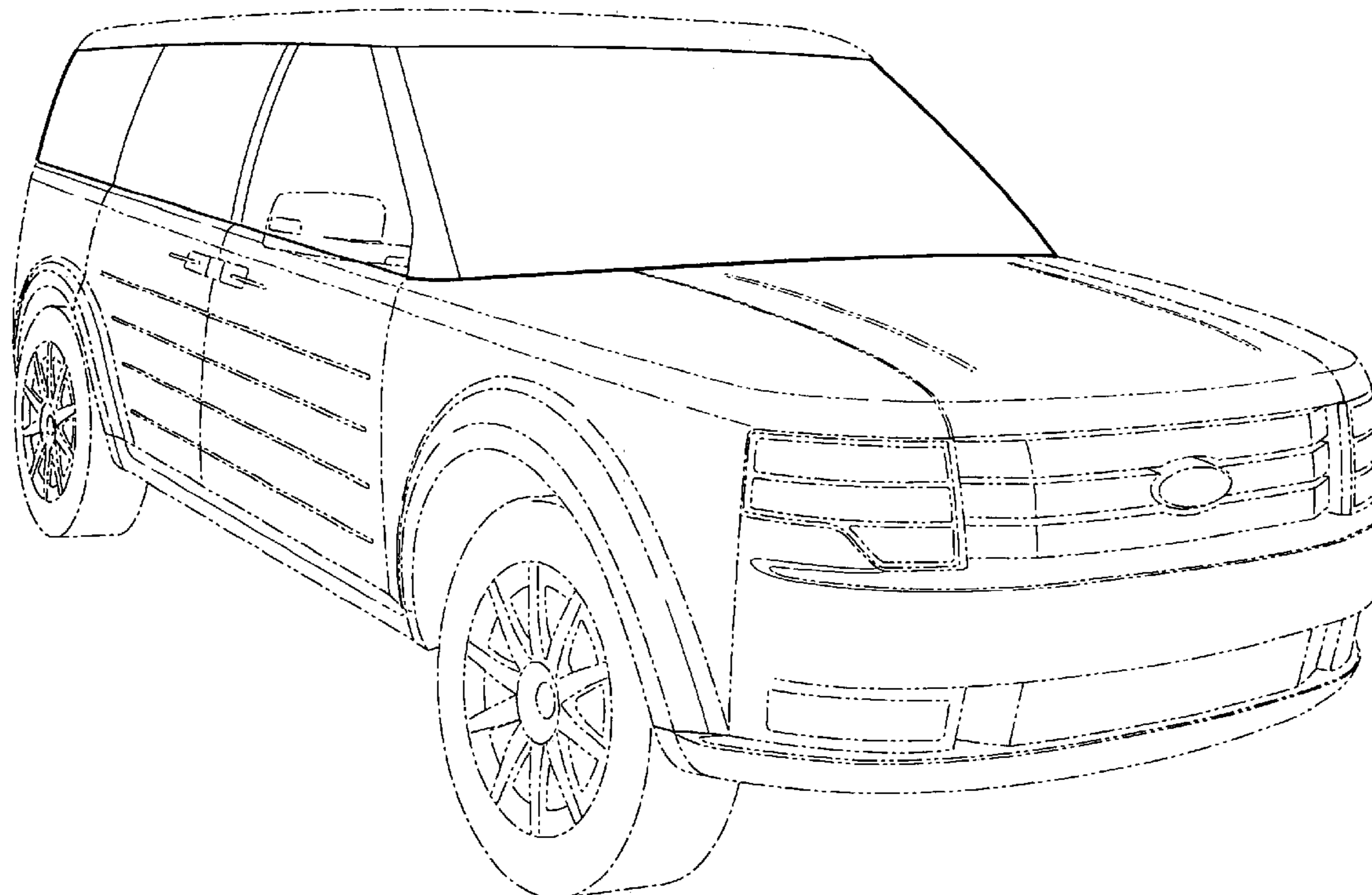

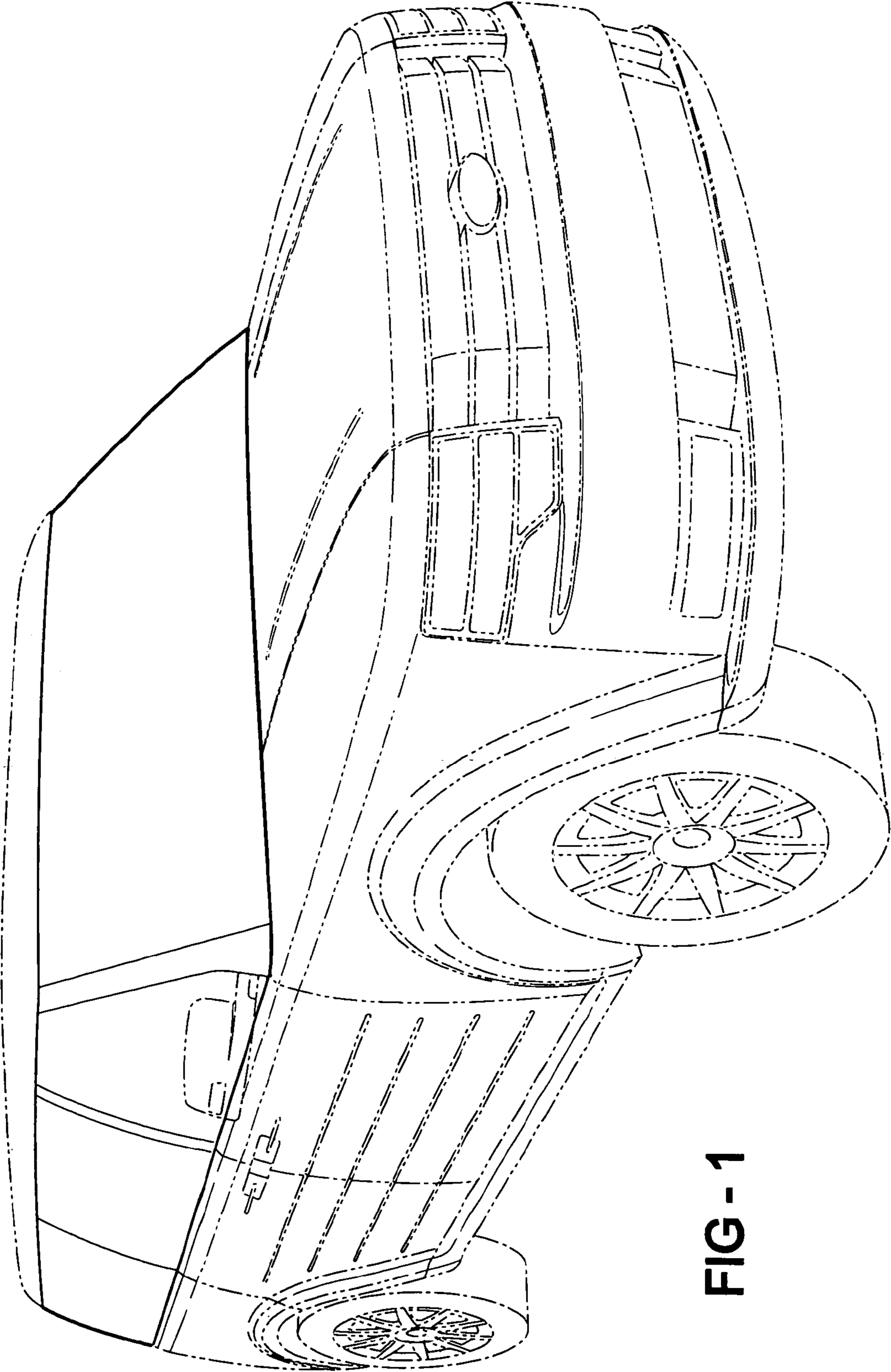

FIG - 1

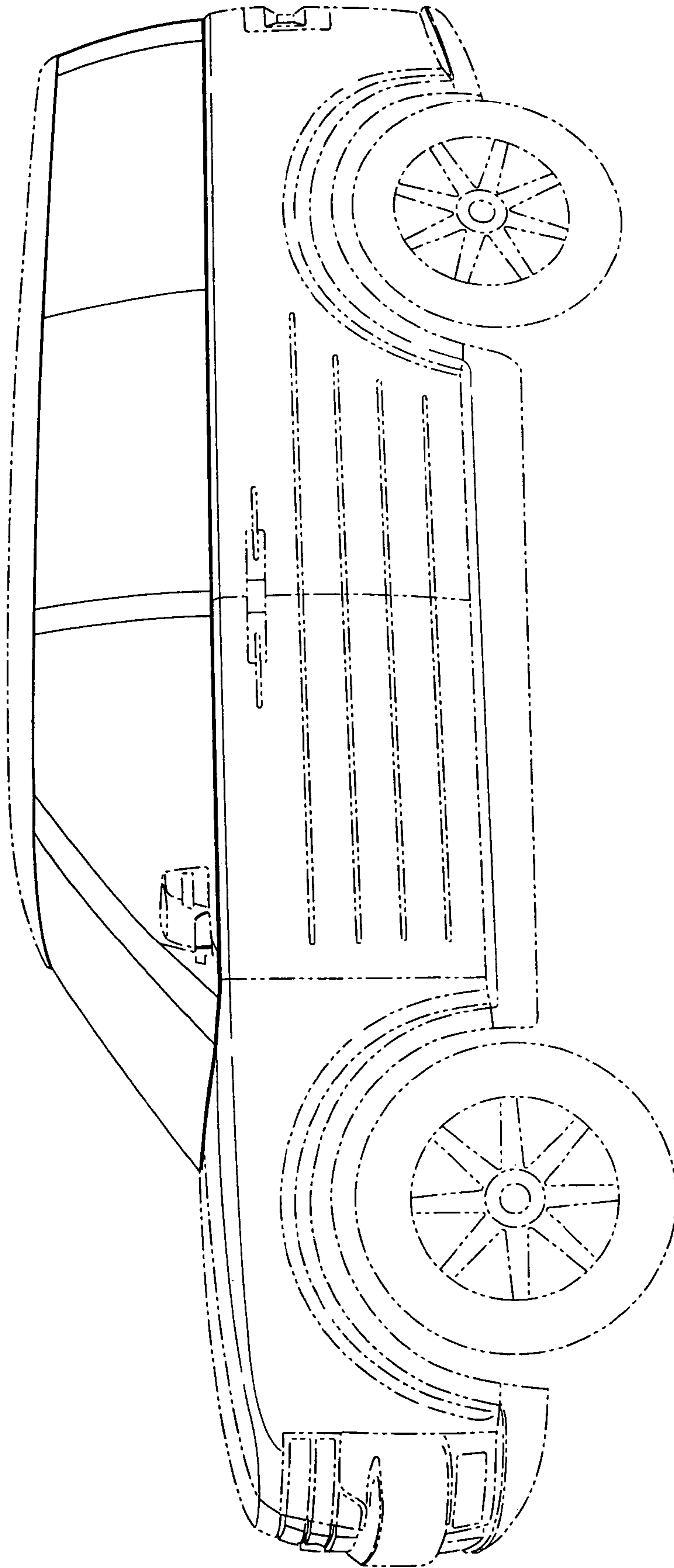

FIG - 2

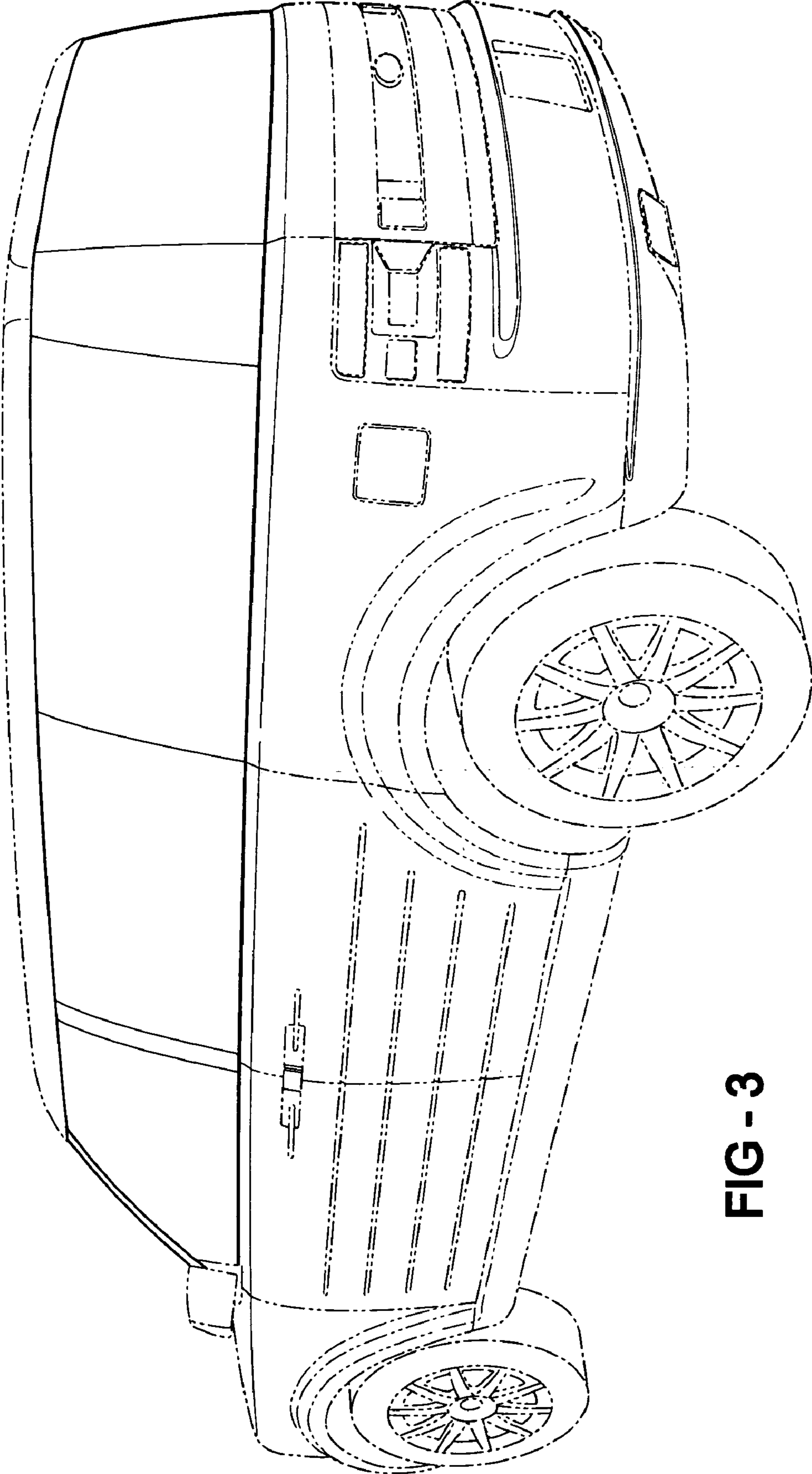

FIG - 3