

US00D543912S

(12) **United States Design Patent**
Kato et al.

(10) **Patent No.:** **US D543,912 S**

(45) **Date of Patent:** **** Jun. 5, 2007**

(54) **BUMPER FOR AN AUTOMOBILE**

(75) Inventors: **Shinno Kato**, Aichi (JP); **Robert Seiji Mochizuki**, Newport Beach, CA (US); **Kevin Kenneth Hunter**, Newport Beach, CA (US)

(73) Assignee: **Toyota Jidosha Kabushiki Kaisha** (JP)

(**) Term: **14 Years**

(21) Appl. No.: **29/260,517**

(22) Filed: **May 25, 2006**

(51) **LOC (8) Cl.** **12-16**

(52) **U.S. Cl.** **D12/169**

(58) **Field of Classification Search** D12/90-92,
D12/86, 169, 196, 163; 296/180.1, 180.2;
293/102, 113, 115, 117, 120
See application file for complete search history.

(56) **References Cited**

U.S. PATENT DOCUMENTS

D525,921 S * 8/2006 Fujiwara et al. D12/169
D533,819 S * 12/2006 Hogios D12/169
D534,105 S * 12/2006 Schiavone et al. D12/169

OTHER PUBLICATIONS

Photograph of AUDI 4, from www.audiusa.com, updated in 2002 (1 page).

Photograph of Hyundai Sonata, from www.hyundaiusa.com, updated in 1999 (1 page).

* cited by examiner

Primary Examiner—Melody N. Brown
(74) *Attorney, Agent, or Firm*—SAIDMAN DesignLaw Group

(57) **CLAIM**

The ornamental design for a bumper for an automobile, as shown and described.

DESCRIPTION

FIG. 1 is a front perspective view of a bumper for an automobile showing our new design;
FIG. 2 is a front elevational view thereof;
FIG. 3 is a top plan view thereof;
FIG. 4 is a bottom plan view thereof;
FIG. 5 is a right-side elevational view thereof; and,
FIG. 6 is a left-side elevational view thereof.
The rear view is not part of the claimed design.
The broken lines are environmental and form no part of the claimed design.

1 Claim, 3 Drawing Sheets

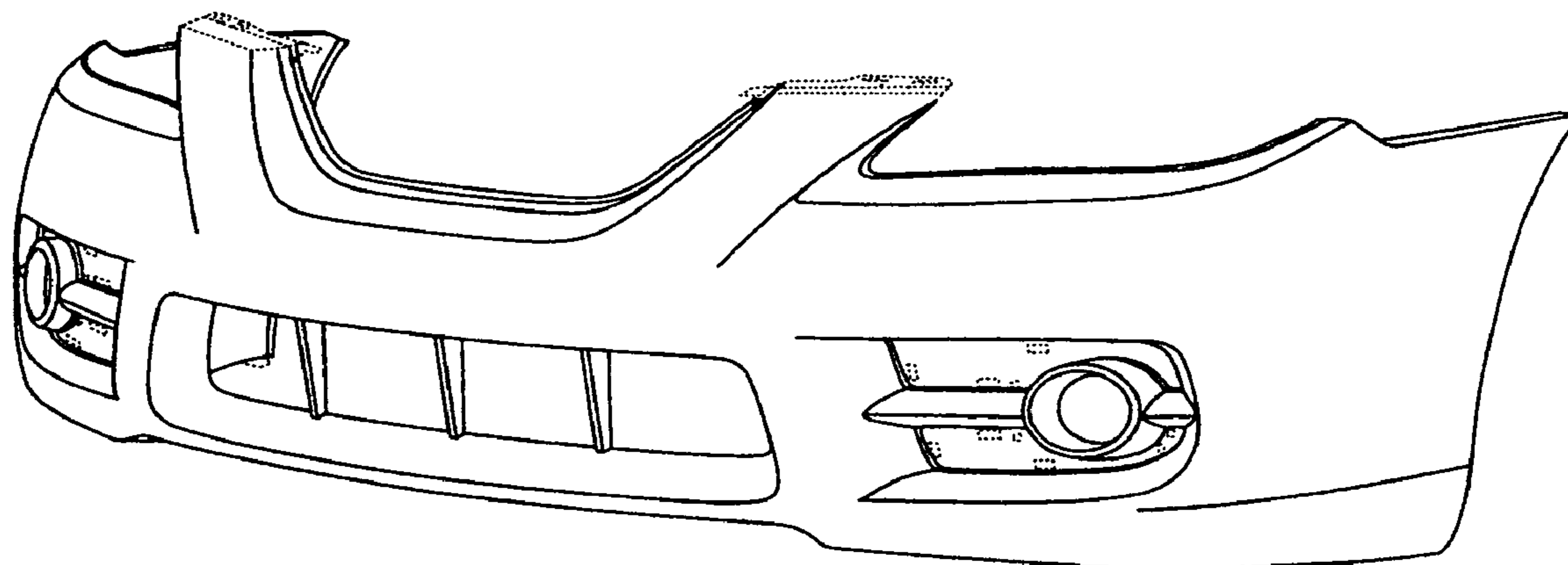

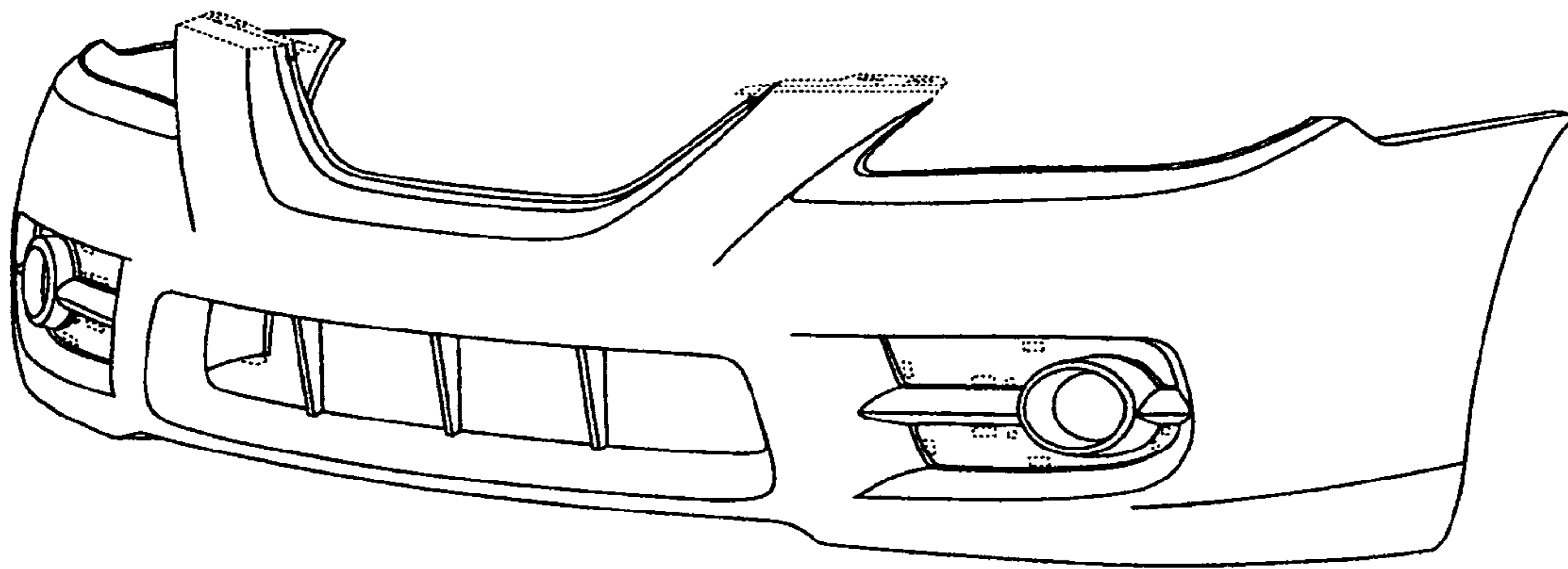

Fig. 1

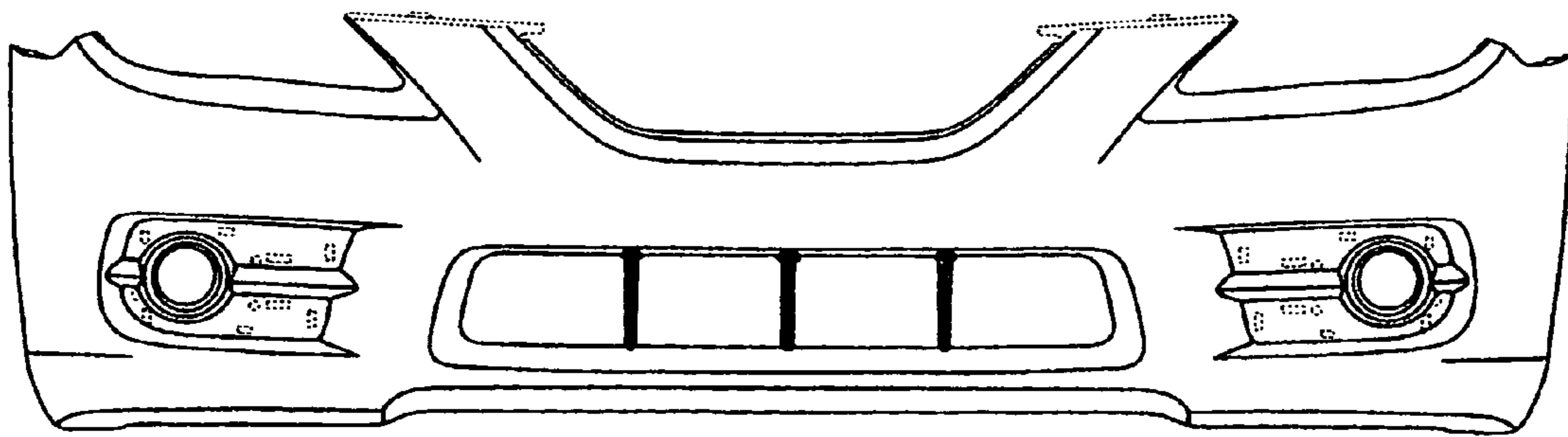

Fig. 2

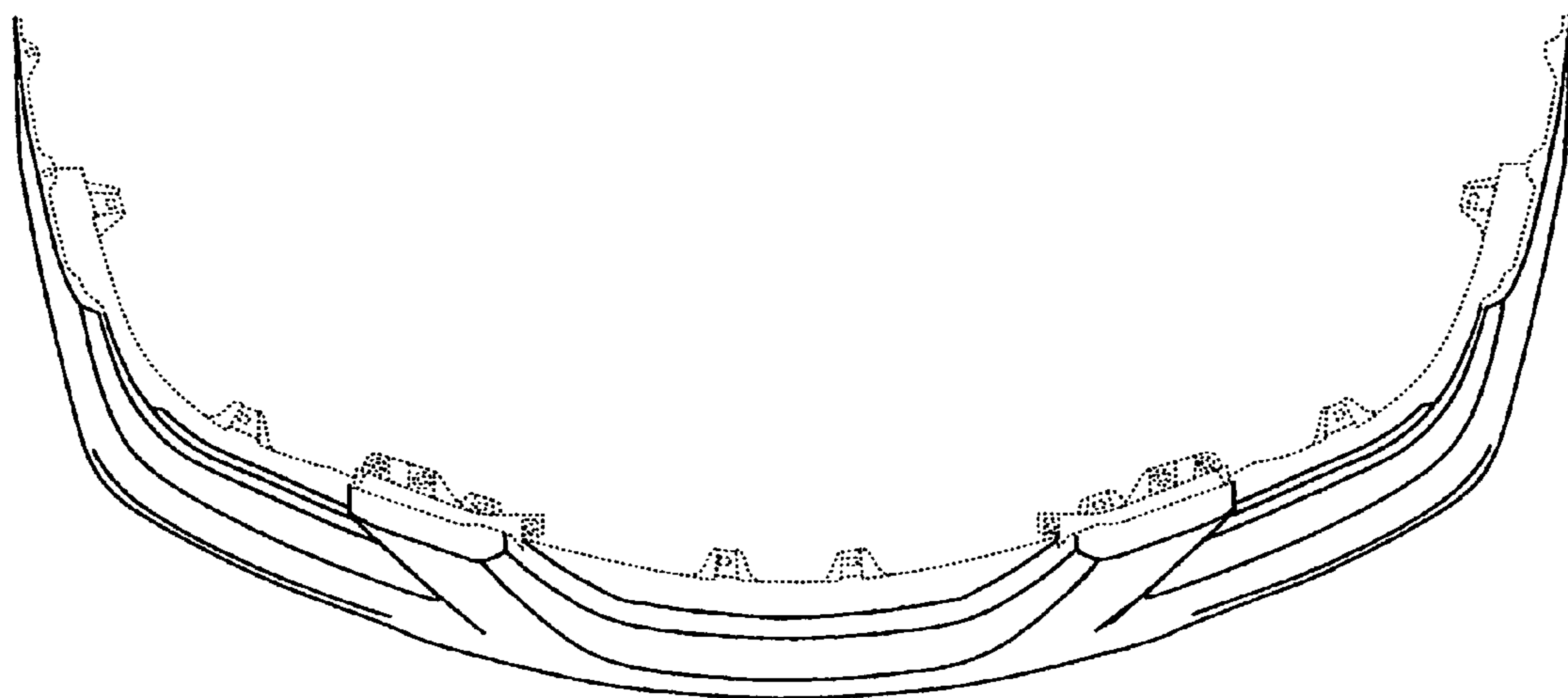

Fig. 3

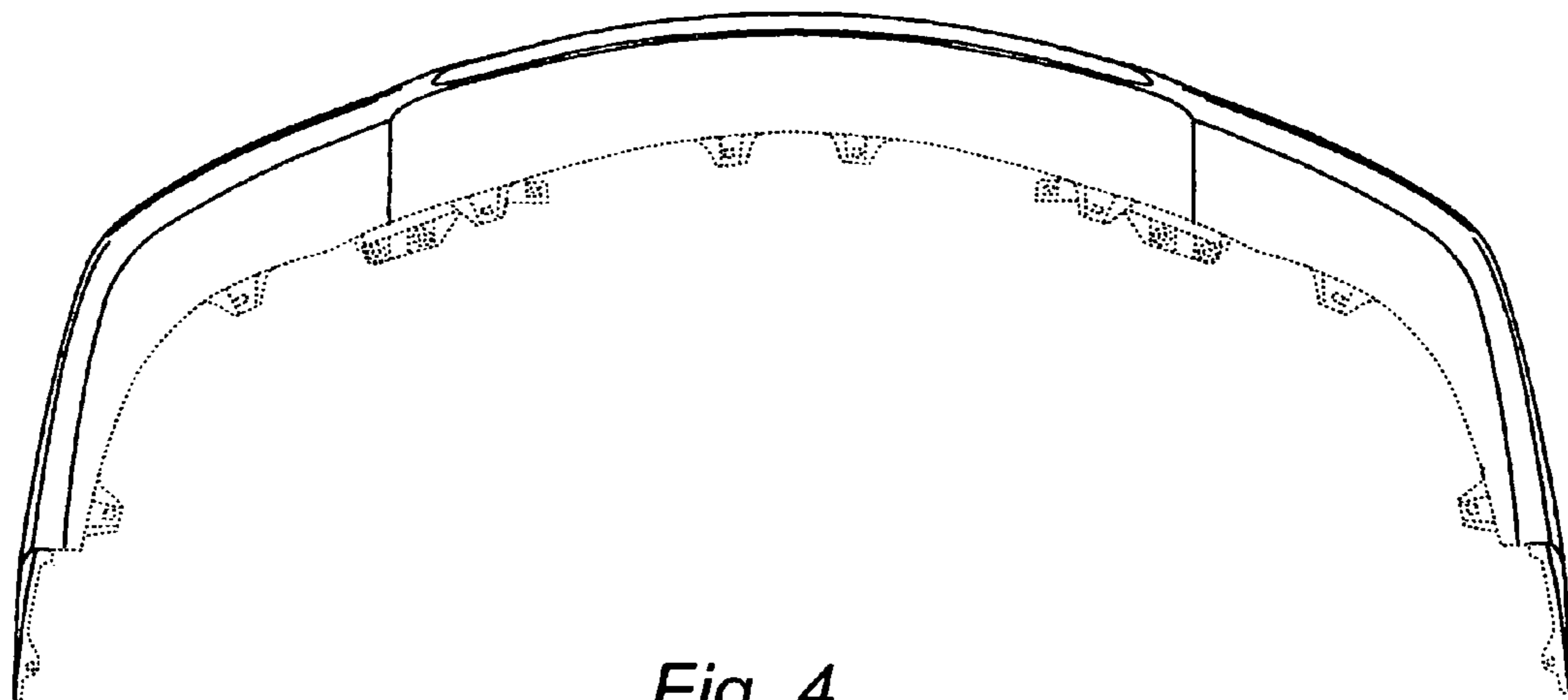

Fig. 4

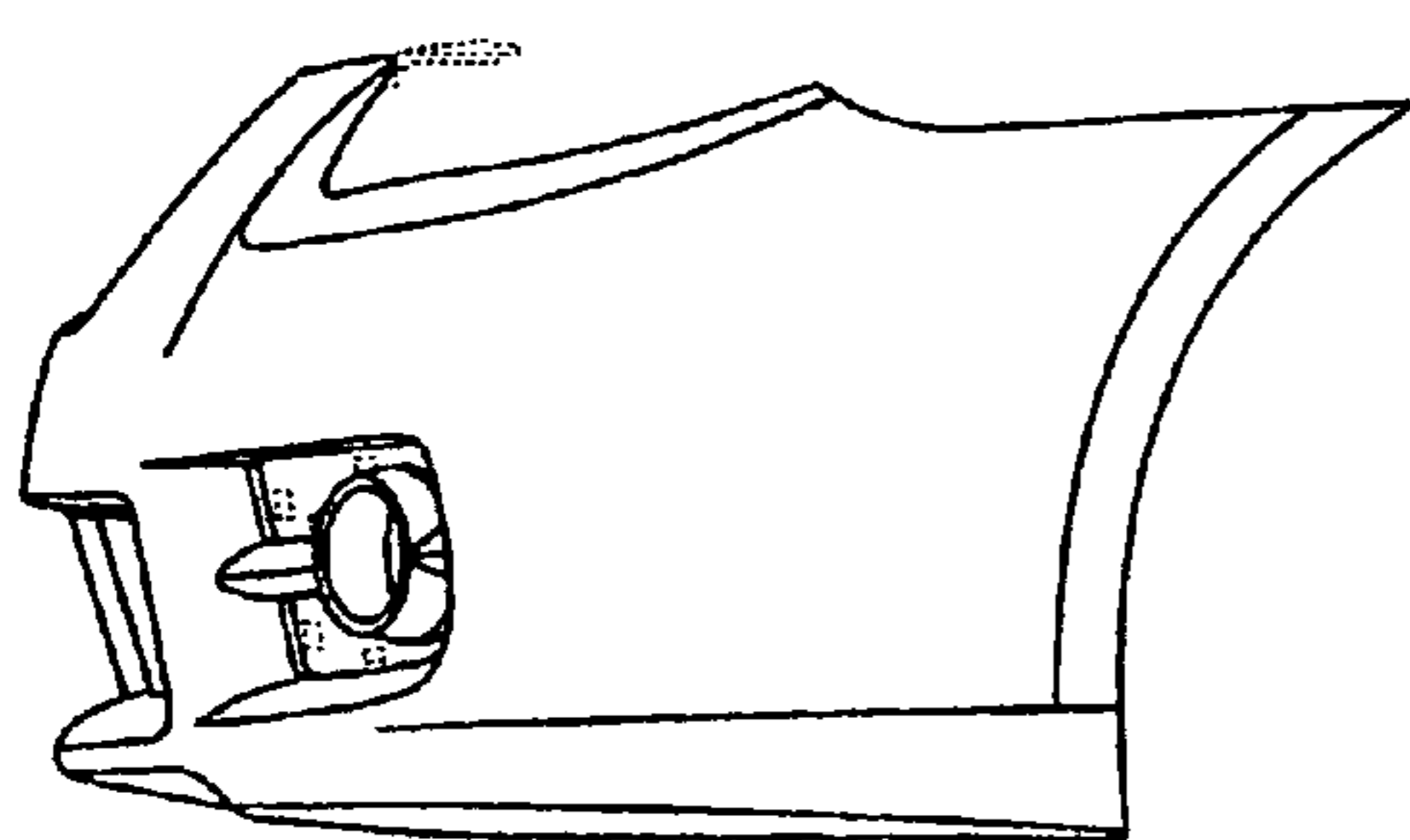

Fig. 5

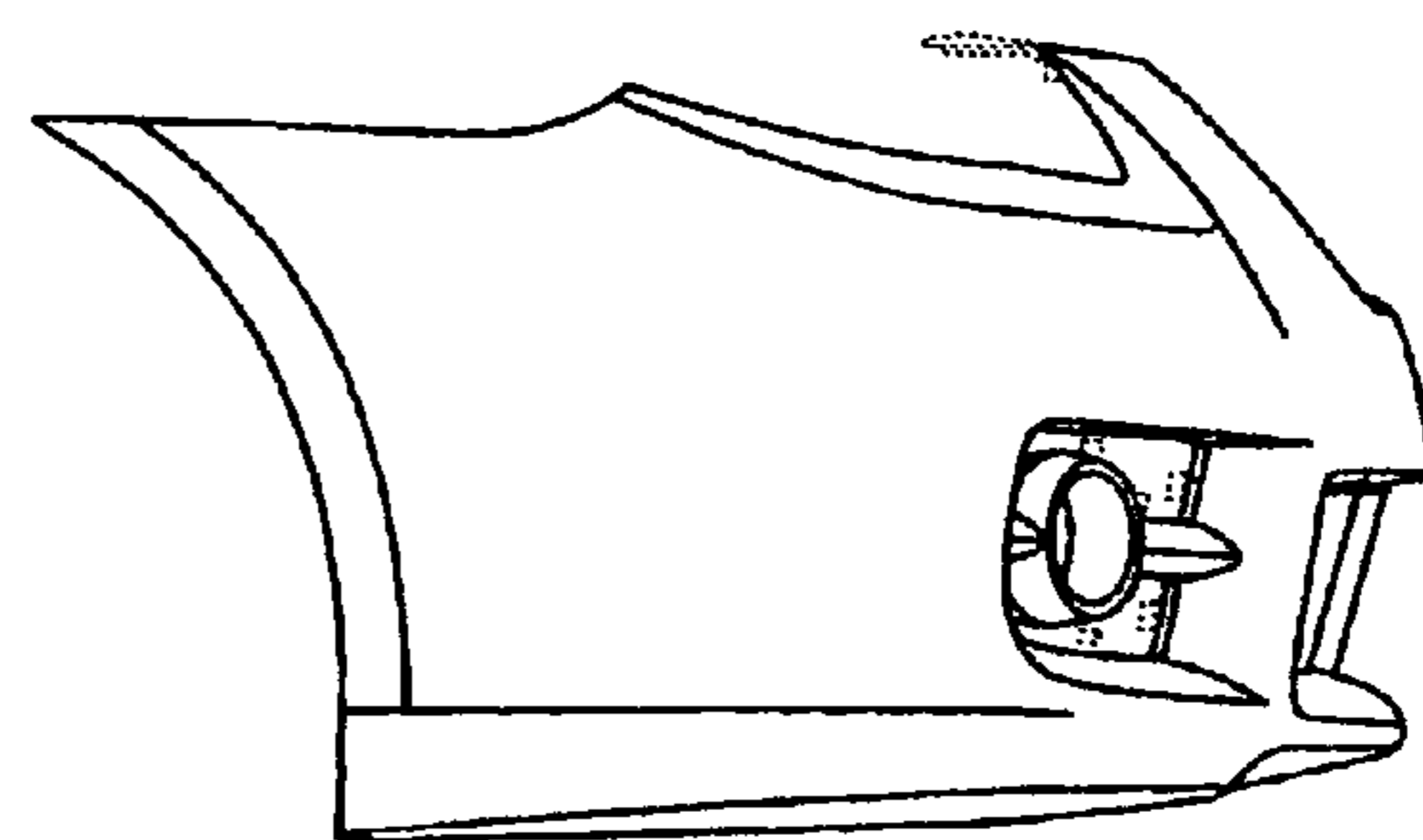

Fig. 6