

US00D543907S

(12) **United States Design Patent**
Amian

(10) **Patent No.:** **US D543,907 S**

(45) **Date of Patent:** **** Jun. 5, 2007**

(54) **SPLIT REPLACEMENT BOOT**

(76) Inventor: **Jesus Rey Amian**, 84-1015 Hana St.,
Waianae, HI (US) 96792

(**) Term: **14 Years**

(21) Appl. No.: **29/210,584**

(22) Filed: **Aug. 3, 2004**

(51) **LOC (8) Cl.** **12-16**

(52) **U.S. Cl.** **D12/160**

(58) **Field of Classification Search** D12/159,
D12/160; 92/34-39; 285/57, 145.5, 226,
285/299; 280/5.5, 5.501-5.509, 5.51, 5.511,
280/86.754; 180/84

See application file for complete search history.

(56) **References Cited**

U.S. PATENT DOCUMENTS

2,432,025	A *	12/1947	Lorenz	137/590
2,731,259	A *	1/1956	Dentler	267/141.1
2,758,612	A *	8/1956	Zaleski	285/114
3,135,295	A *	6/1964	Ziebold	138/121
3,162,371	A *	12/1964	Palmer et al.	239/327
3,169,785	A *	2/1965	Ziebold	285/226

3,369,411	A *	2/1968	Hines	74/18.2
4,531,450	A *	7/1985	Yamada et al.	92/48
4,834,419	A *	5/1989	Kozaki et al.	280/5.503
5,941,335	A *	8/1999	Krishner	180/255
6,182,979	B1 *	2/2001	Lee	280/5.507

* cited by examiner

Primary Examiner—Doris Clark
Assistant Examiner—Michael Pratt

(57) **CLAIM**

The ornamental design for the split replacement boot, as shown.

DESCRIPTION

FIG. 1 is a front perspective view of a split replacement boot showing my new design as applied in use on an axle of a vehicle;

FIG. 2 is a front elevation view thereof, with an indent on the inside wall and overlap on the outside wall of the boot;

FIG. 3 is a front elevation view thereof, with an indent on the outside wall and overlap on the inside wall of the boot; and,

FIG. 4 is a side elevation view thereof.

1 Claim, 4 Drawing Sheets

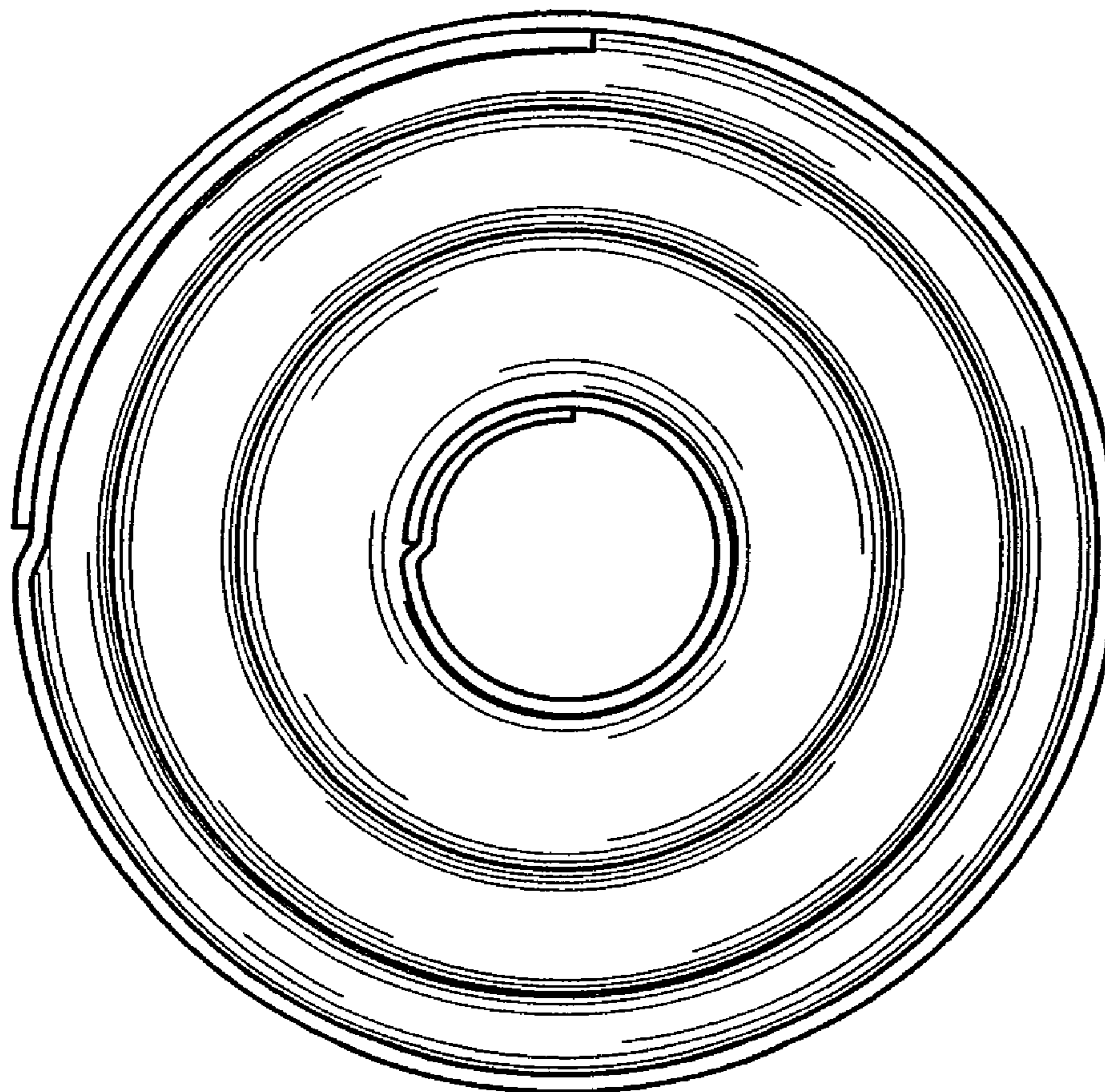

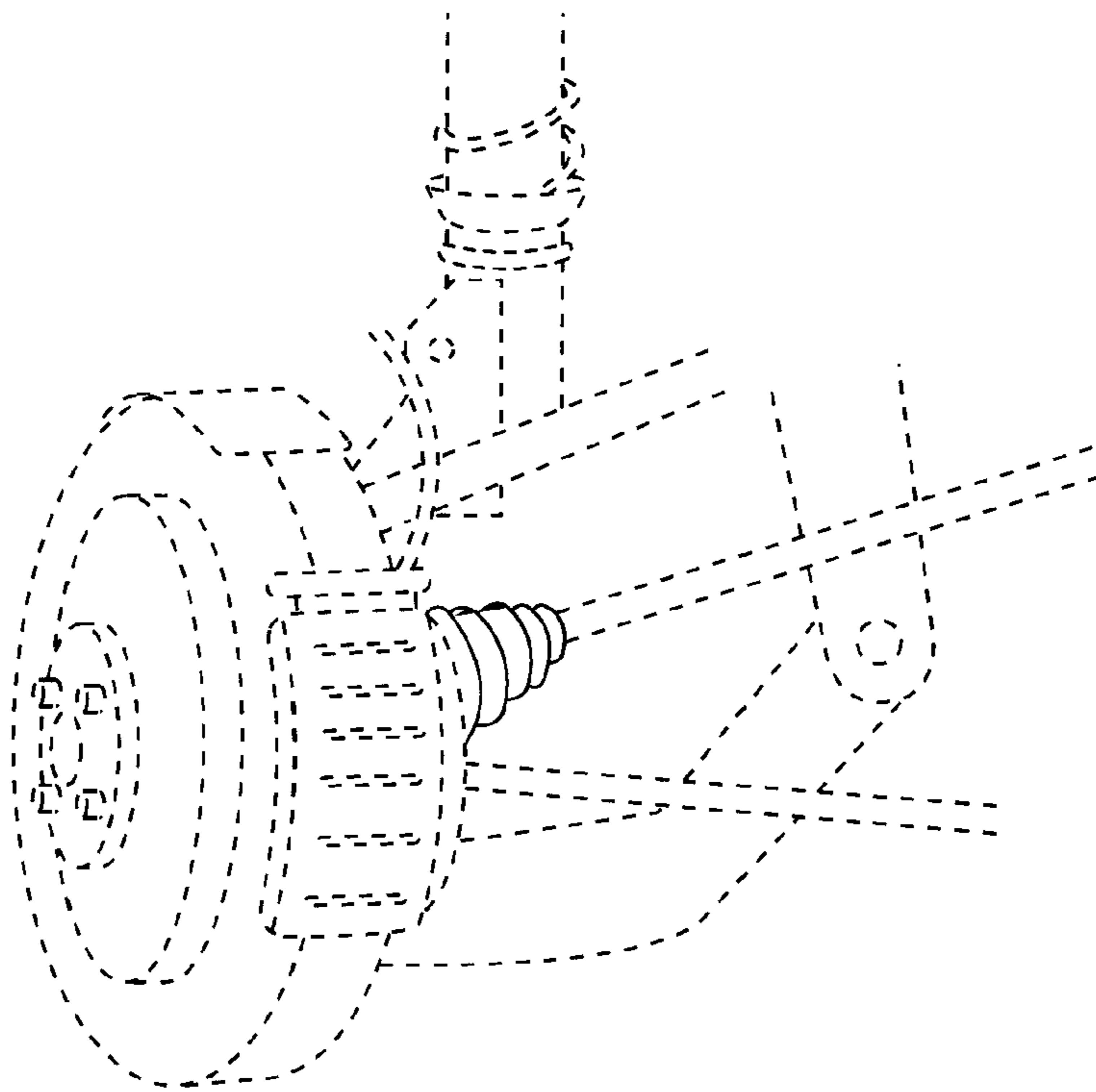

FIG. 1

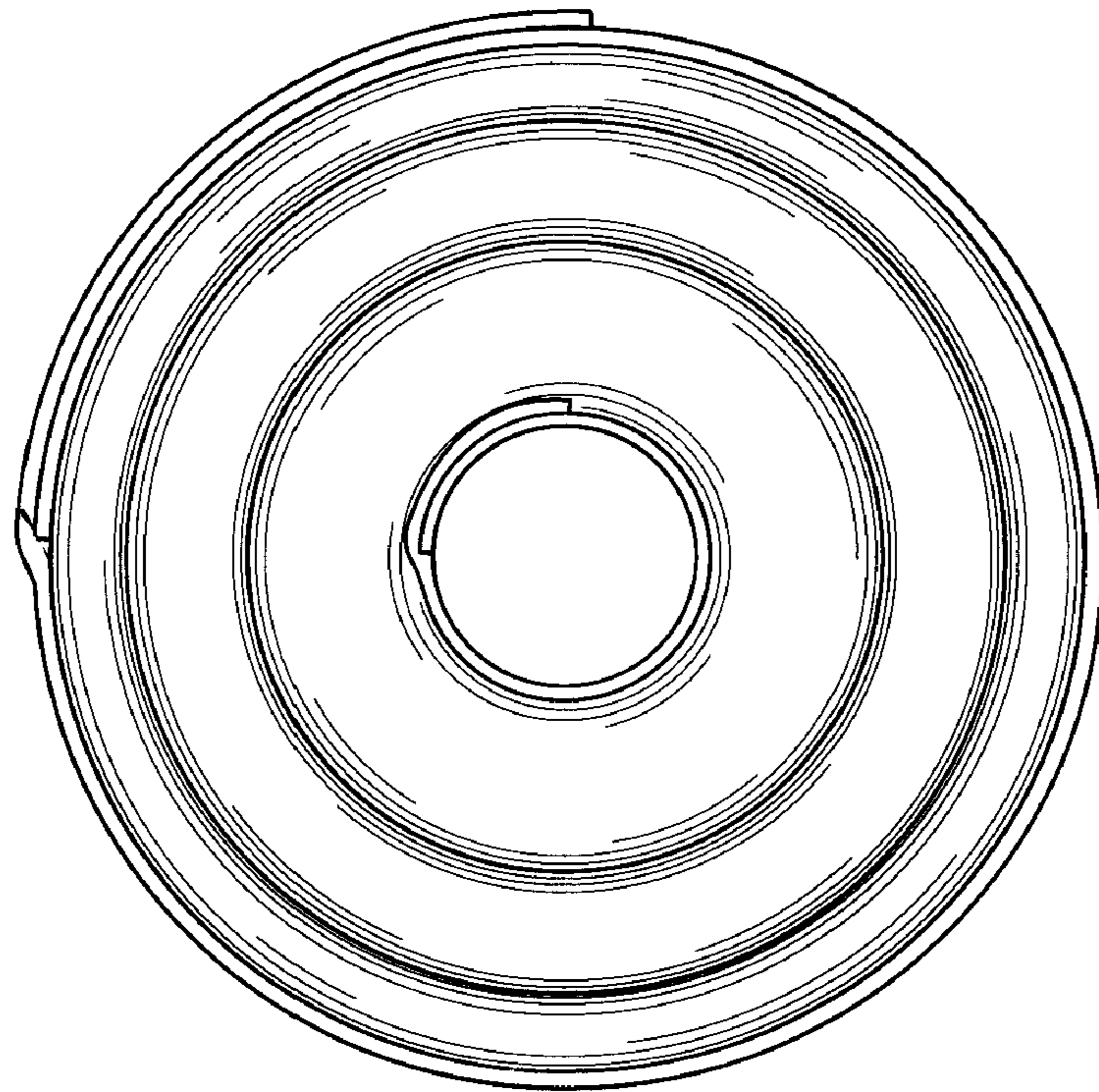

FIG. 2

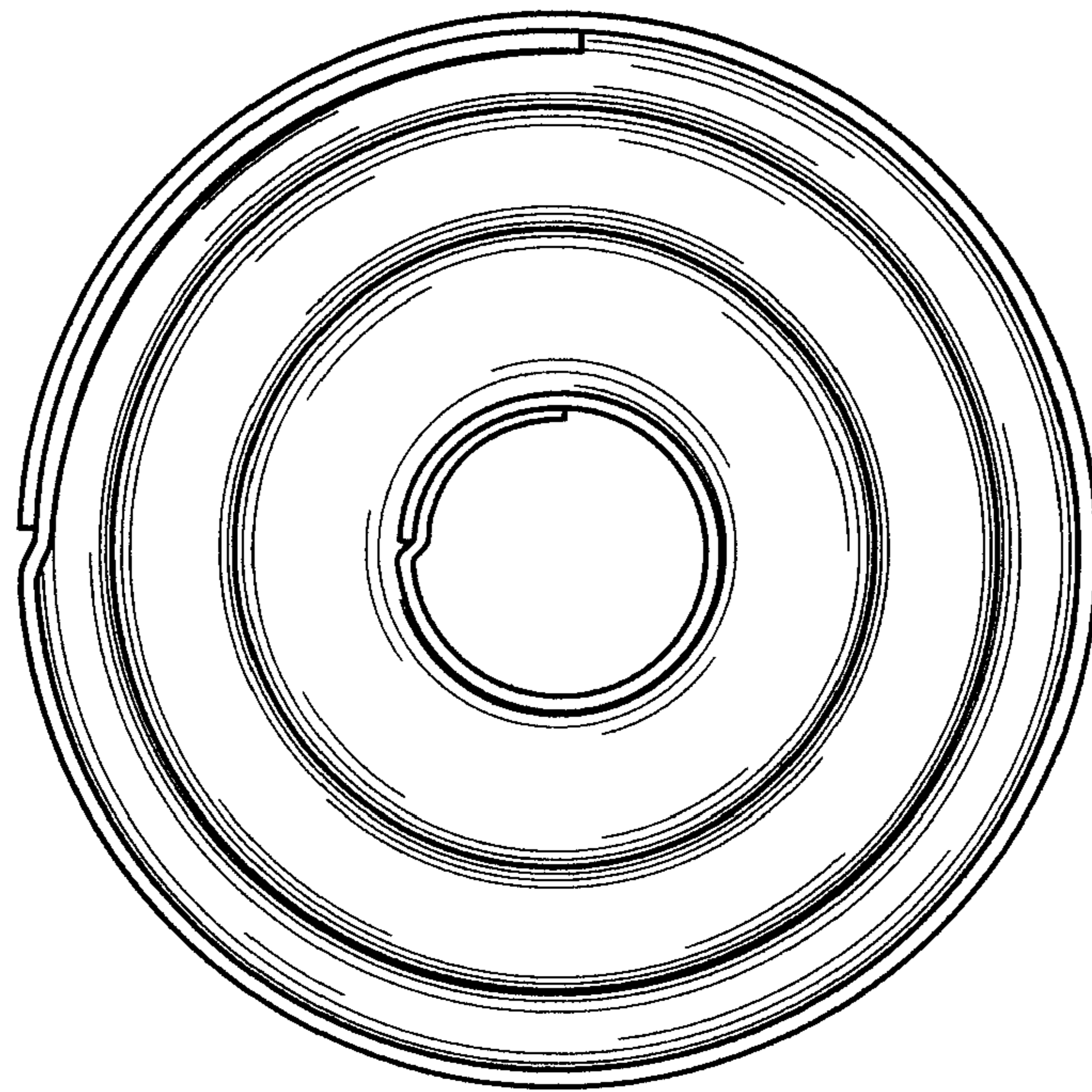

FIG. 3

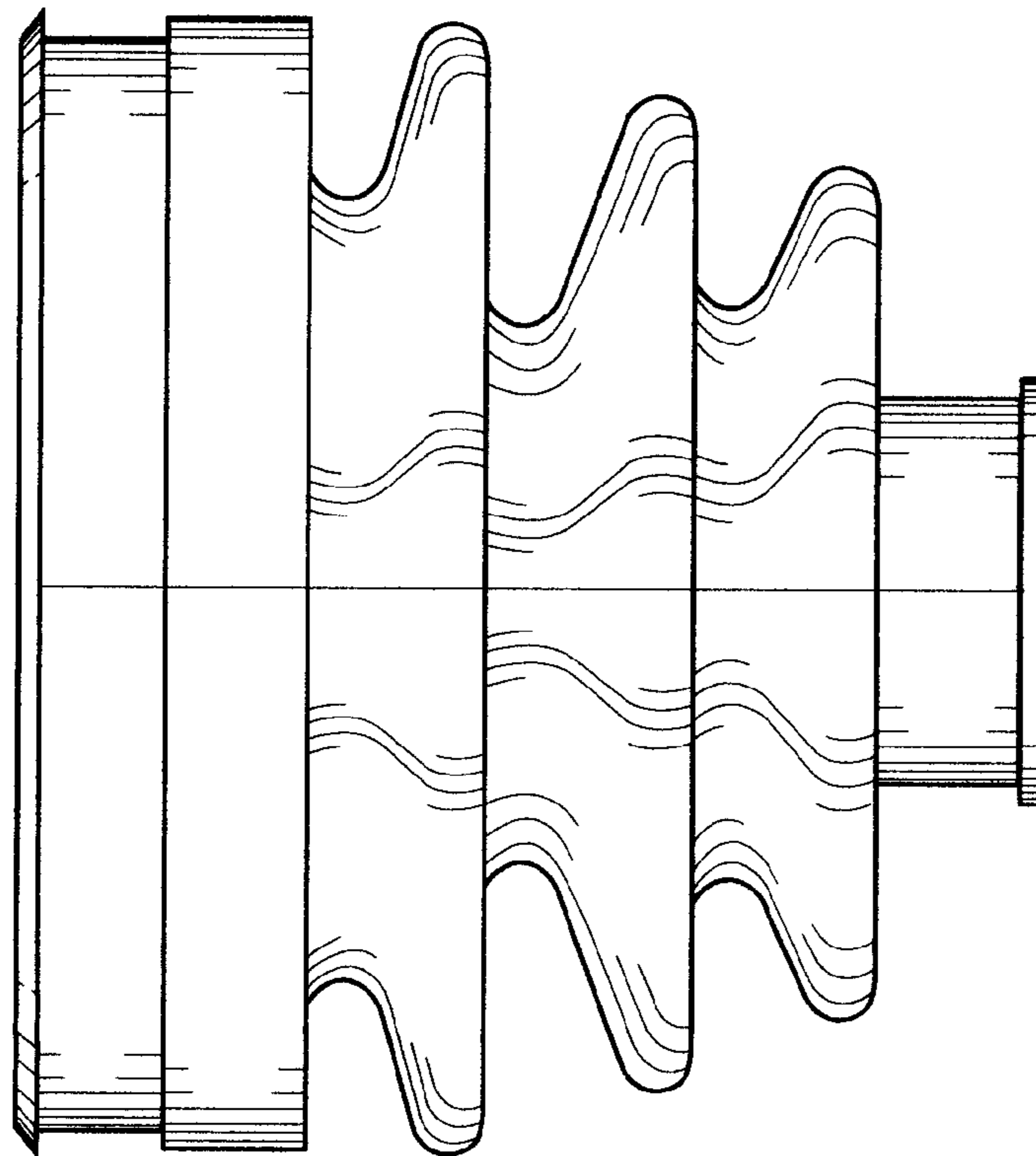

FIG. 4