

US00D543904S

(12) **United States Design Patent**
Chang

(10) **Patent No.:** **US D543,904 S**

(45) **Date of Patent:** **** Jun. 5, 2007**

(54) **MOTORCYCLE**

(76) Inventor: **Chen-Hsiung Chang**, No. 54, Sec. 1,
Jhongshan Rd., Sinjhuang City, Taipei
Hsien (TW)

(**) Term: **14 Years**

(21) Appl. No.: **29/246,734**

(22) Filed: **May 5, 2006**

(51) **LOC (8) Cl.** **12-11**

(52) **U.S. Cl.** **D12/110**

(58) **Field of Classification Search** D12/110;
180/219, 220

See application file for complete search history.

(56) **References Cited**

U.S. PATENT DOCUMENTS

D299,709 S *	2/1989	Miura et al.	D12/110
D475,950 S *	6/2003	Kawano et al.	D12/110
D490,750 S *	6/2004	Hoshino	D12/110
D514,987 S *	2/2006	Hsiao	D12/110

* cited by examiner

Primary Examiner—Alan P. Douglas

Assistant Examiner—Linda Brooks

(74) *Attorney, Agent, or Firm*—patenttm.us; James H.
Walters

(57) **CLAIM**

The ornamental design for a motorcycle, as show and described.

DESCRIPTION

FIG. 1 is a perspective view of a motorcycle, showing my new design;

FIG. 2 is a front elevational view thereof;

FIG. 3 is a rear elevational view thereof;

FIG. 4 is a left elevational view thereof, wherein the scale thereof is reduced;

FIG. 5 is a right elevational view thereof, wherein the scale thereof is reduced; and,

FIG. 6 is a top plan view thereof, wherein a bottom plan view thereof is omitted since it forms no part of the claimed design.

1 Claim, 6 Drawing Sheets

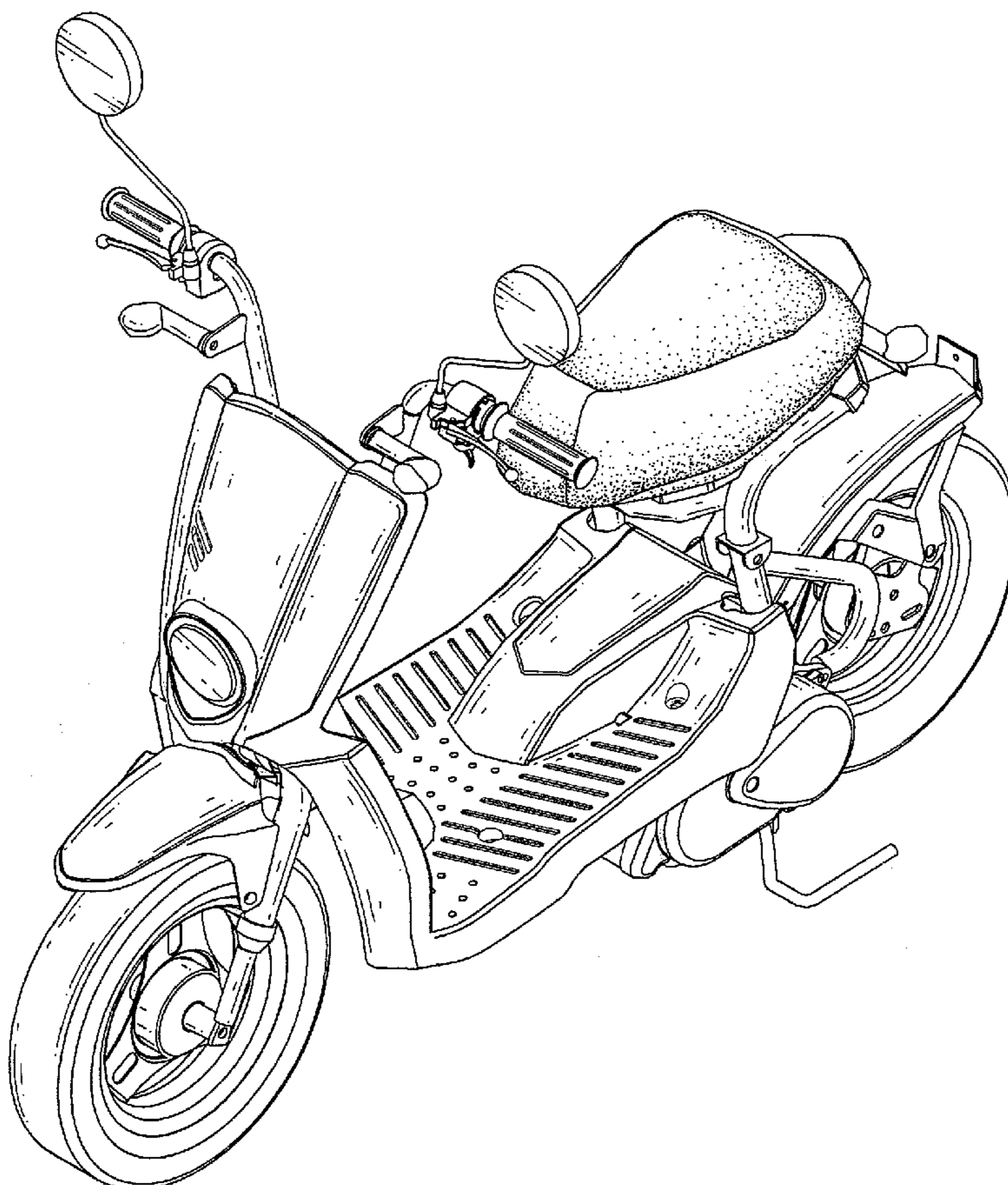

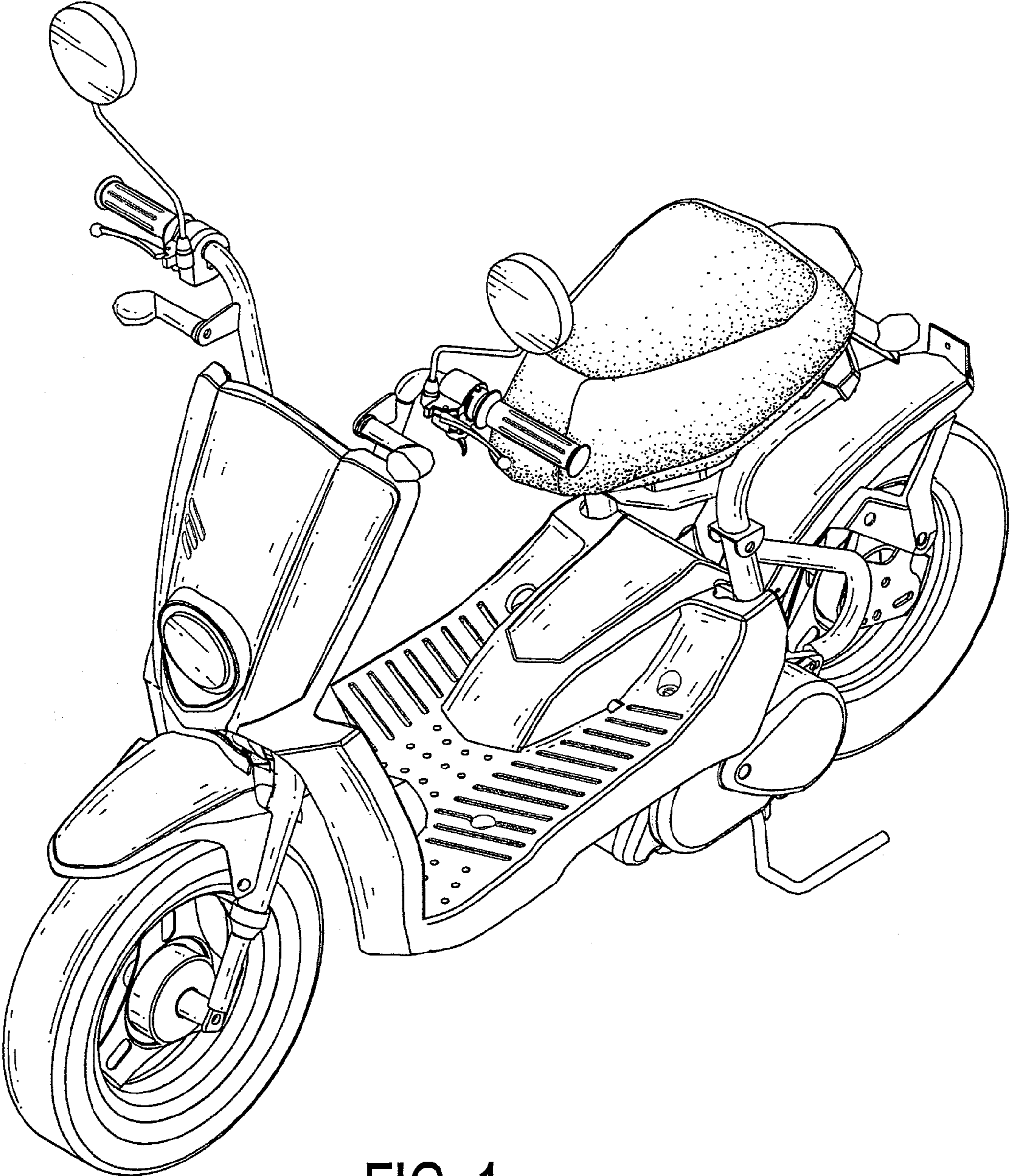

FIG .1

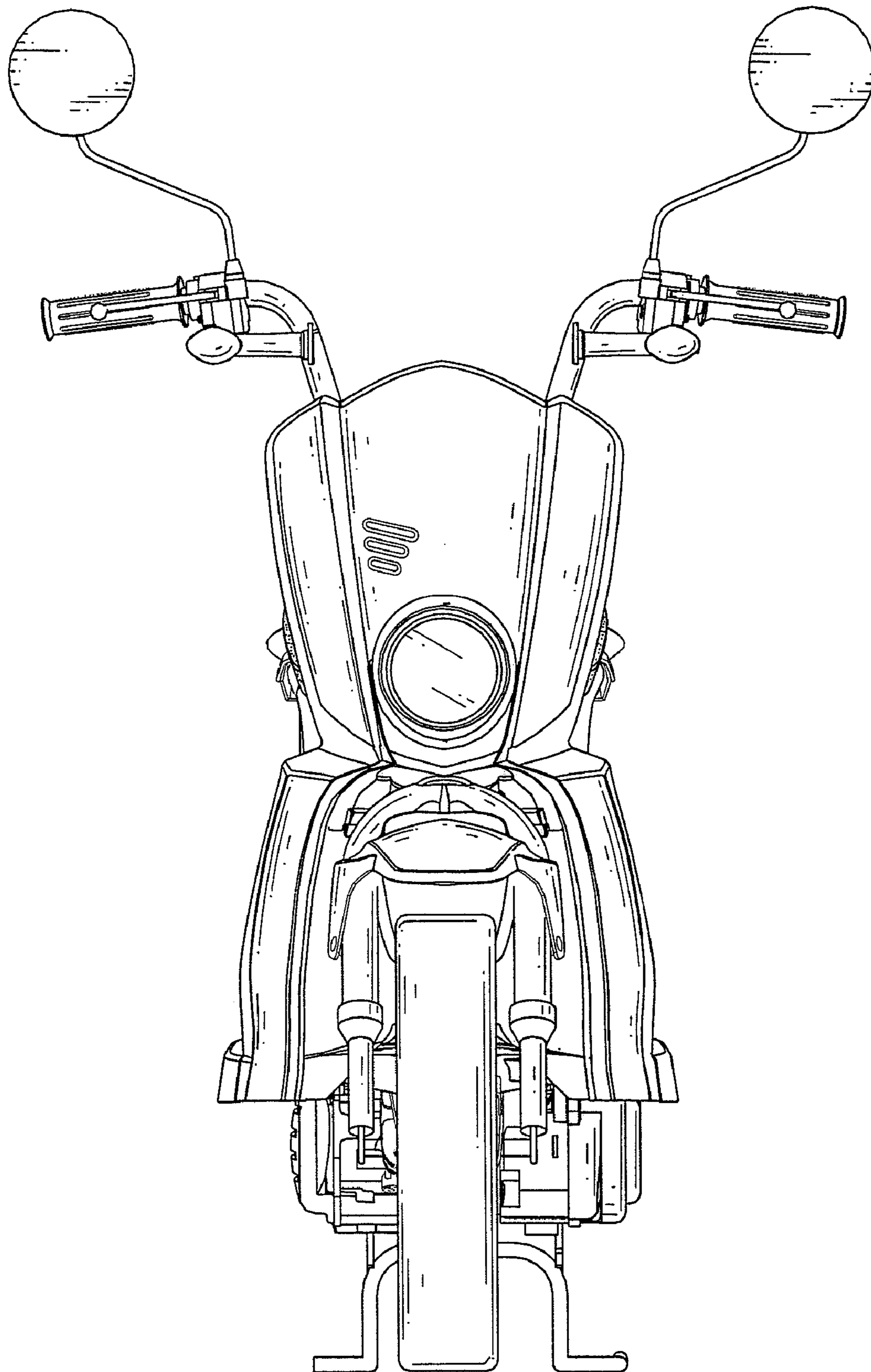

FIG. 2

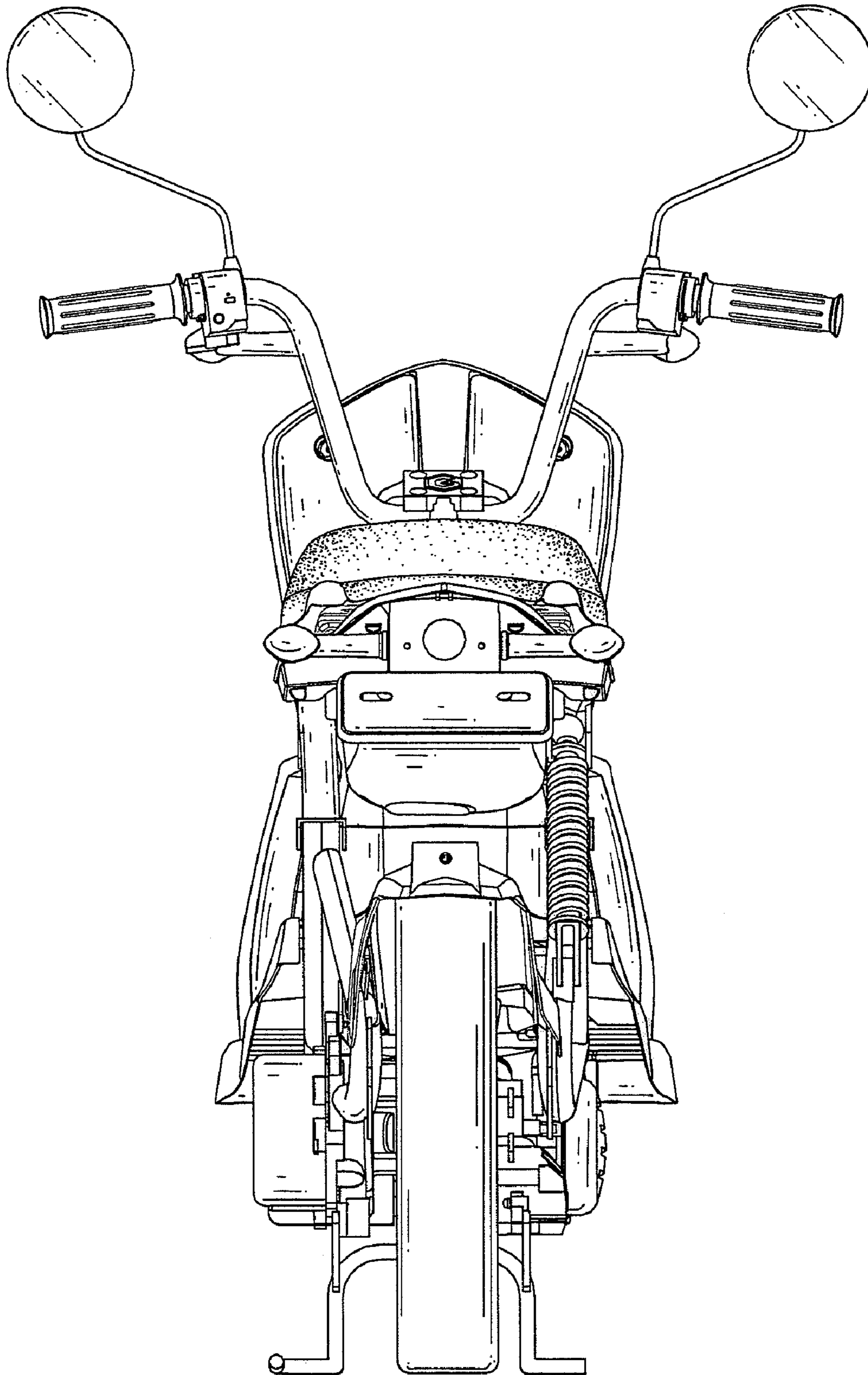

FIG. 3

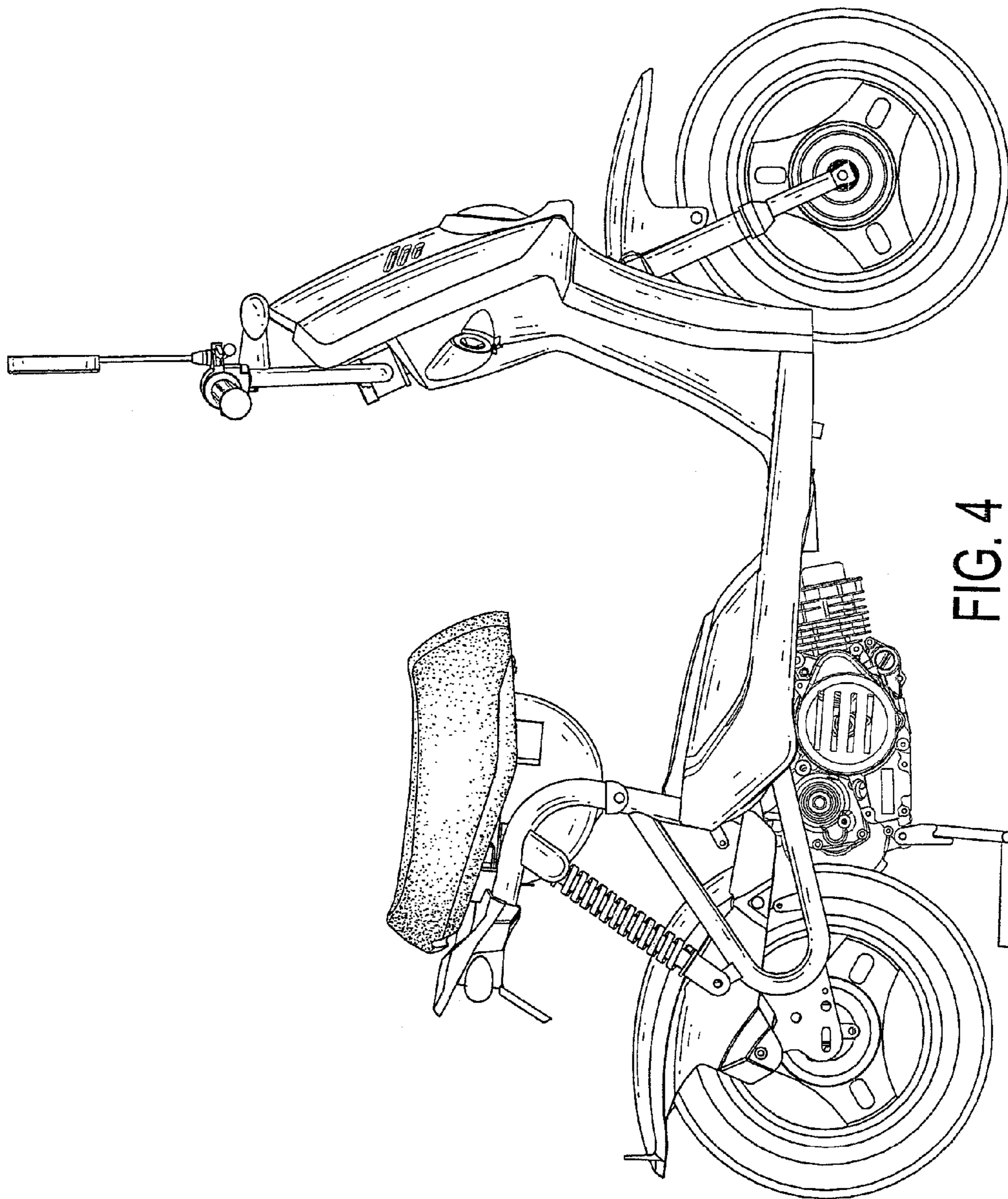

FIG. 4

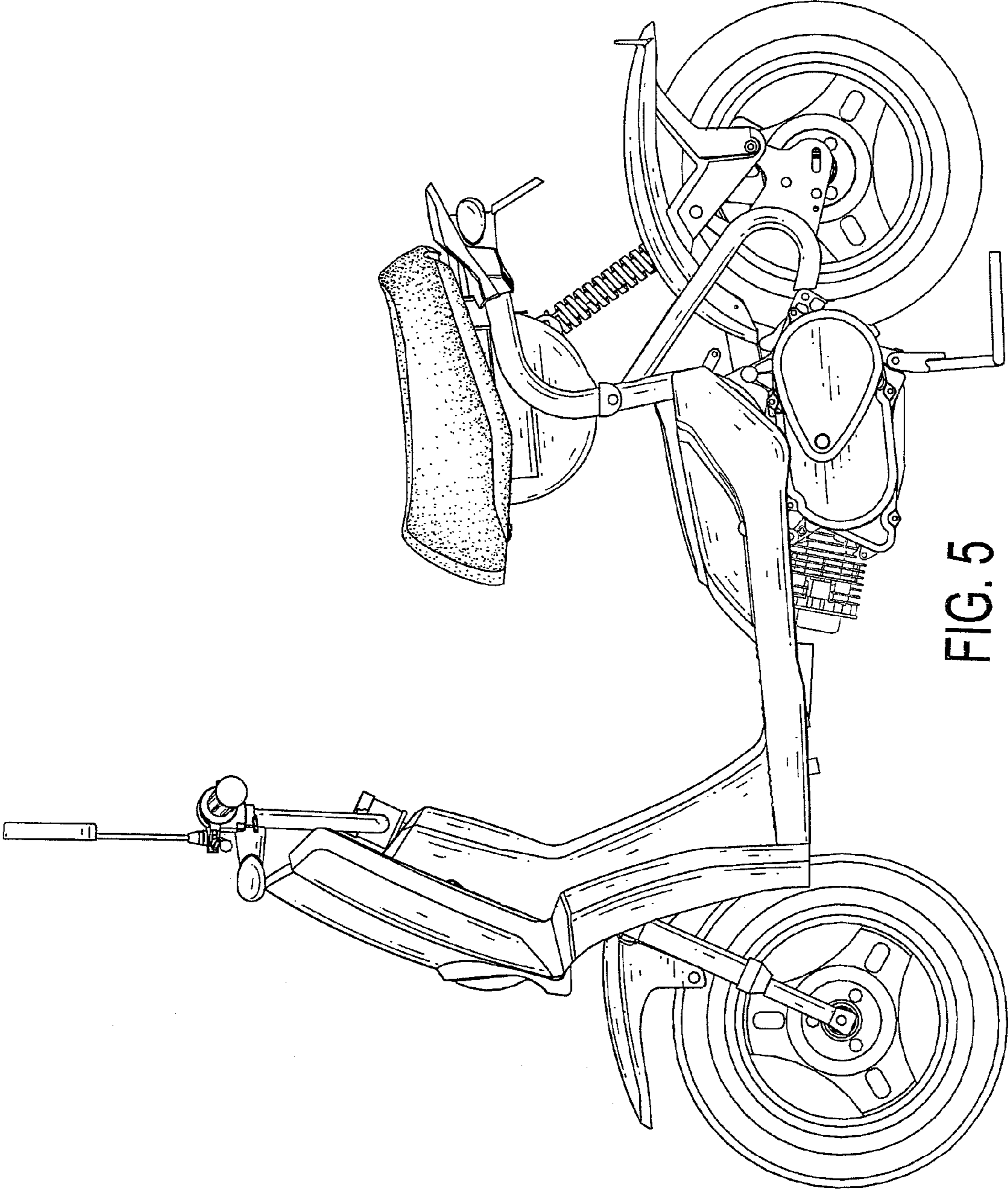

FIG. 5

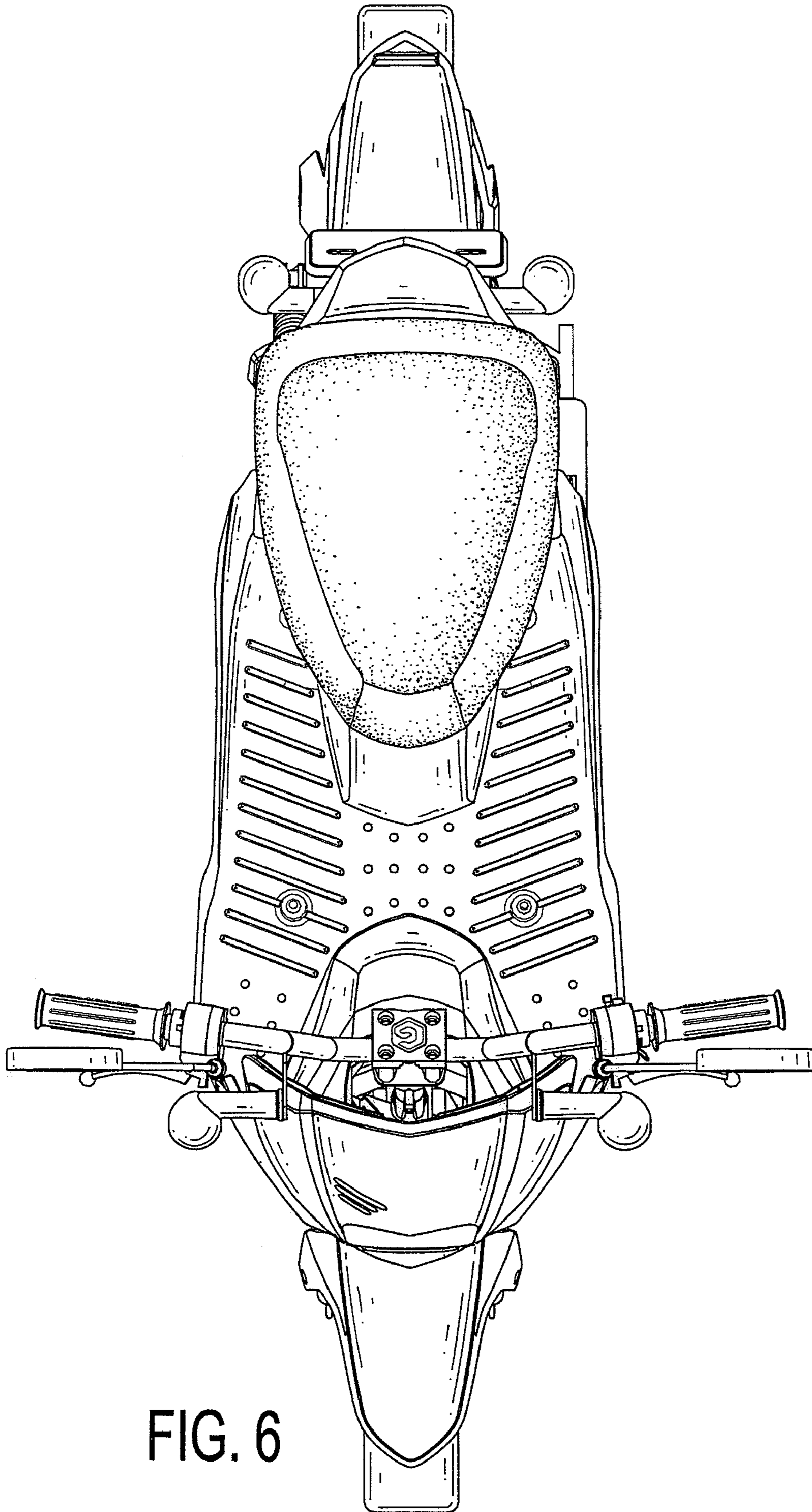

FIG. 6