

US00D543876S

(12) **United States Design Patent**  
**Kalis et al.**

(10) **Patent No.:** **US D543,876 S**  
(45) **Date of Patent:** **\*\* Jun. 5, 2007**

(54) **NAVIGATION DEVICE**

(75) Inventors: **Robert M. Kalis**, Overland Park, KS (US); **Warren R. Stevens**, Olathe, KS (US); **David F. Lammers-Meis**, Olathe, KS (US); **Paul E. Skelton**, Lenexa, KS (US); **Stephen P. Waite**, Blue Springs, MO (US)

(73) Assignee: **Garmin Ltd.** (KY)

(\*\*) Term: **14 Years**

(21) Appl. No.: **29/248,781**

(22) Filed: **Sep. 1, 2006**

**Related U.S. Application Data**

(63) Continuation-in-part of application No. 29/244,329, filed on Dec. 8, 2005.

(51) **LOC (8) Cl.** ..... **10-04**

(52) **U.S. Cl.** ..... **D10/65**

(58) **Field of Classification Search** ..... D10/65, D10/80; D14/347; 342/351, 419, 457, 357.06-357.13; 343/702; 345/87, 104, 133, 156, 168, 173, 345/901-905; 348/180, 184, 315, 739; 364/444, 364/499; 701/206-209, 213, 214  
See application file for complete search history.

(56) **References Cited**

**U.S. PATENT DOCUMENTS**

D366,220 S \* 1/1996 Sakamoto ..... D10/65  
D383,400 S \* 9/1997 Wada ..... D10/65

**OTHER PUBLICATIONS**

<http://www.mynewcheap.co.uk/products/details/snooper-indago-sat-nav-speed-cam/9926>.  
<http://www.poweracoustik.com/nav.html>.  
[http://www.miogps.com/products\\_269features.htm](http://www.miogps.com/products_269features.htm).  
[http://www.akihabaranews.com/en/news\\_9859.html](http://www.akihabaranews.com/en/news_9859.html).  
<http://www.gpsandco.com/articles/newsitem.php?id=4032>.  
<http://www.tomtom.com/products/category.php?ID=0&Language=4>.

\* cited by examiner

*Primary Examiner*—Antoine D. Davis

(74) *Attorney, Agent, or Firm*—David L. Terrell

(57) **CLAIM**

The ornamental design for a navigation device, as shown and described.

**DESCRIPTION**

FIG. 1 is a front perspective view of a navigation device according to the present invention; FIG. 2 is a rear perspective view thereof; FIG. 3 is a front elevational view thereof; FIG. 4 is a top plan view thereof; FIG. 5 is a left side elevational view thereof; FIG. 6 is a rear elevational view thereof; FIG. 7 is a bottom plan view thereof; and, FIG. 8 is a right side elevational view thereof. It should be noted that modifications may be made, equivalents may be employed, and substitutions may be made herein without departing from the scope of the claimed design.

**1 Claim, 3 Drawing Sheets**

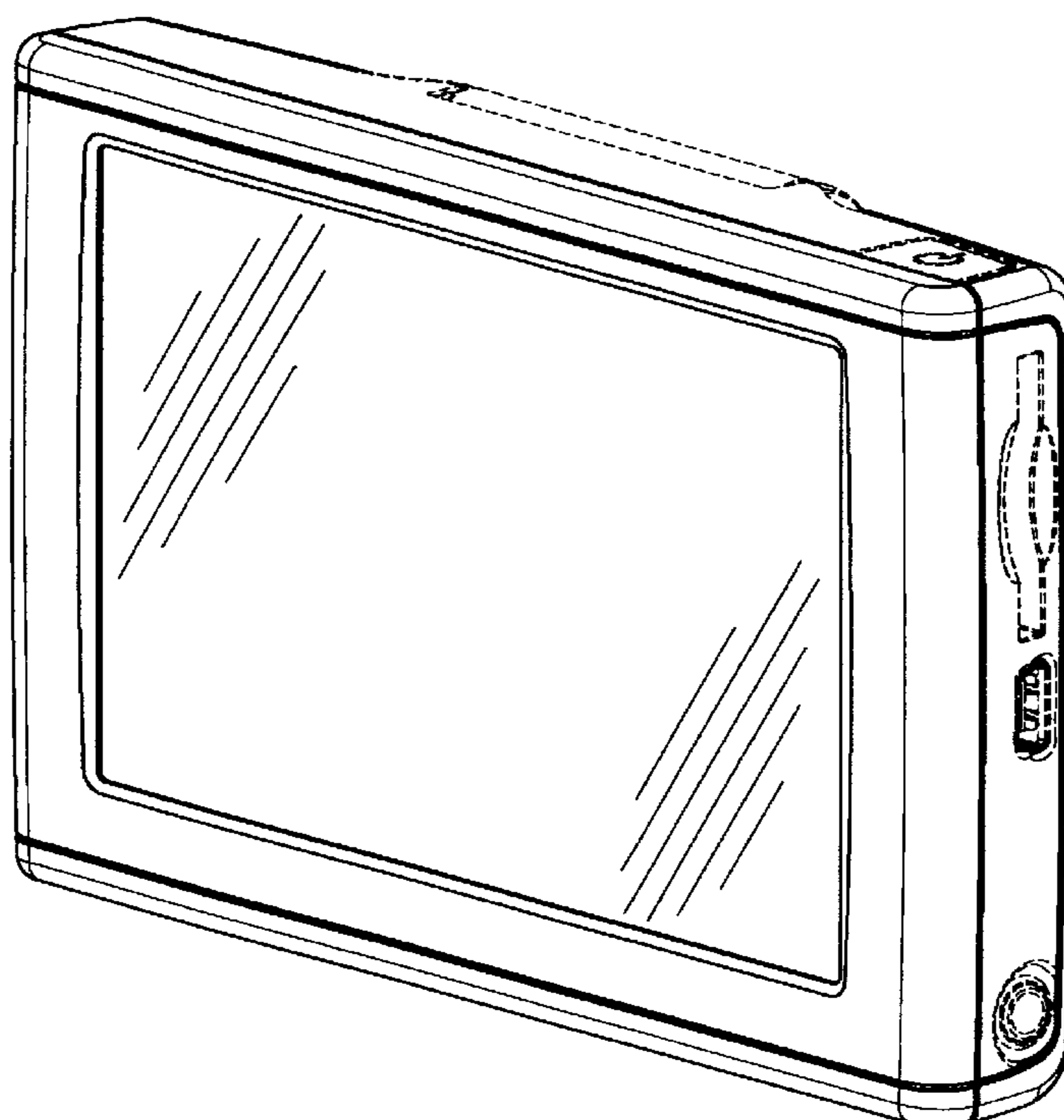

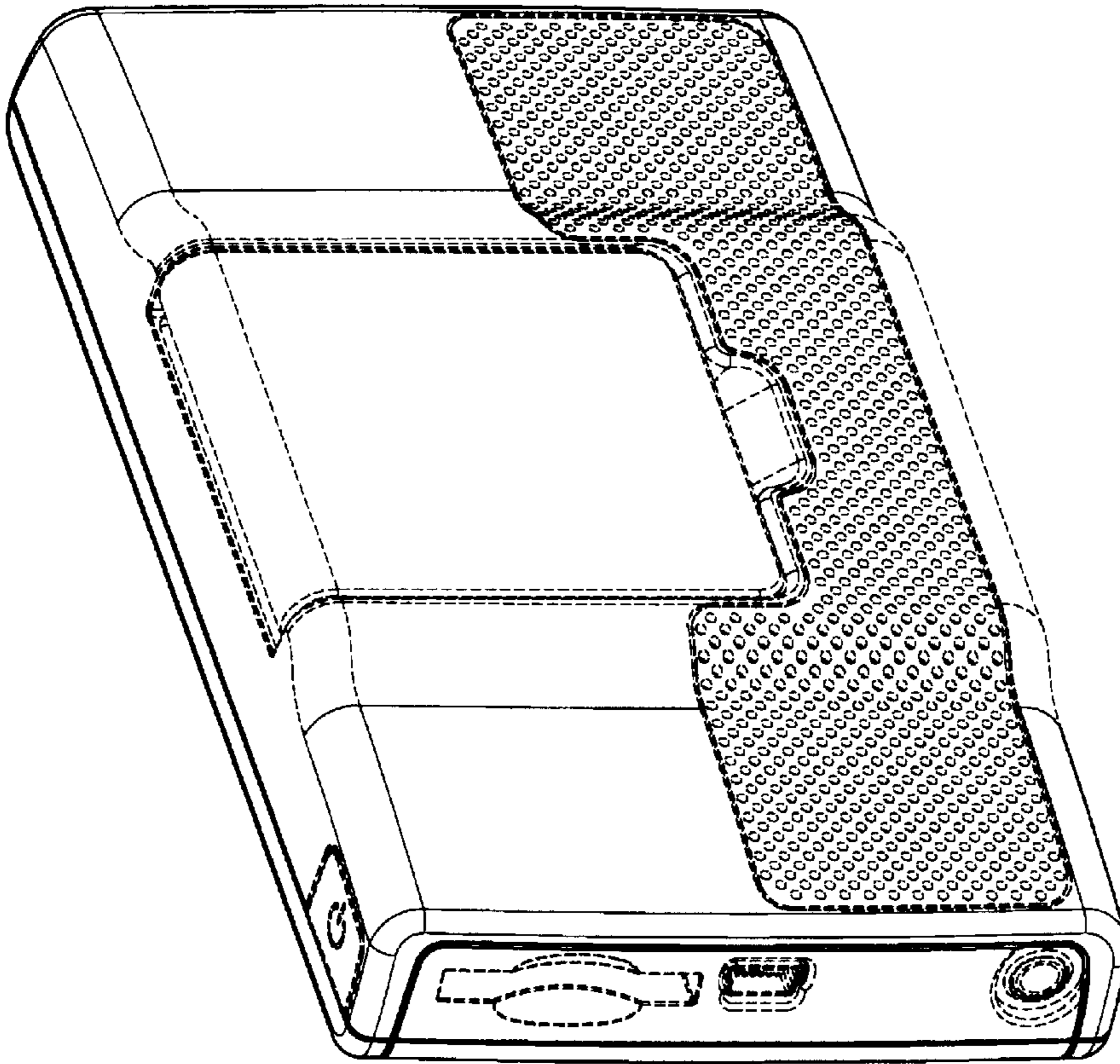

FIG. 2.

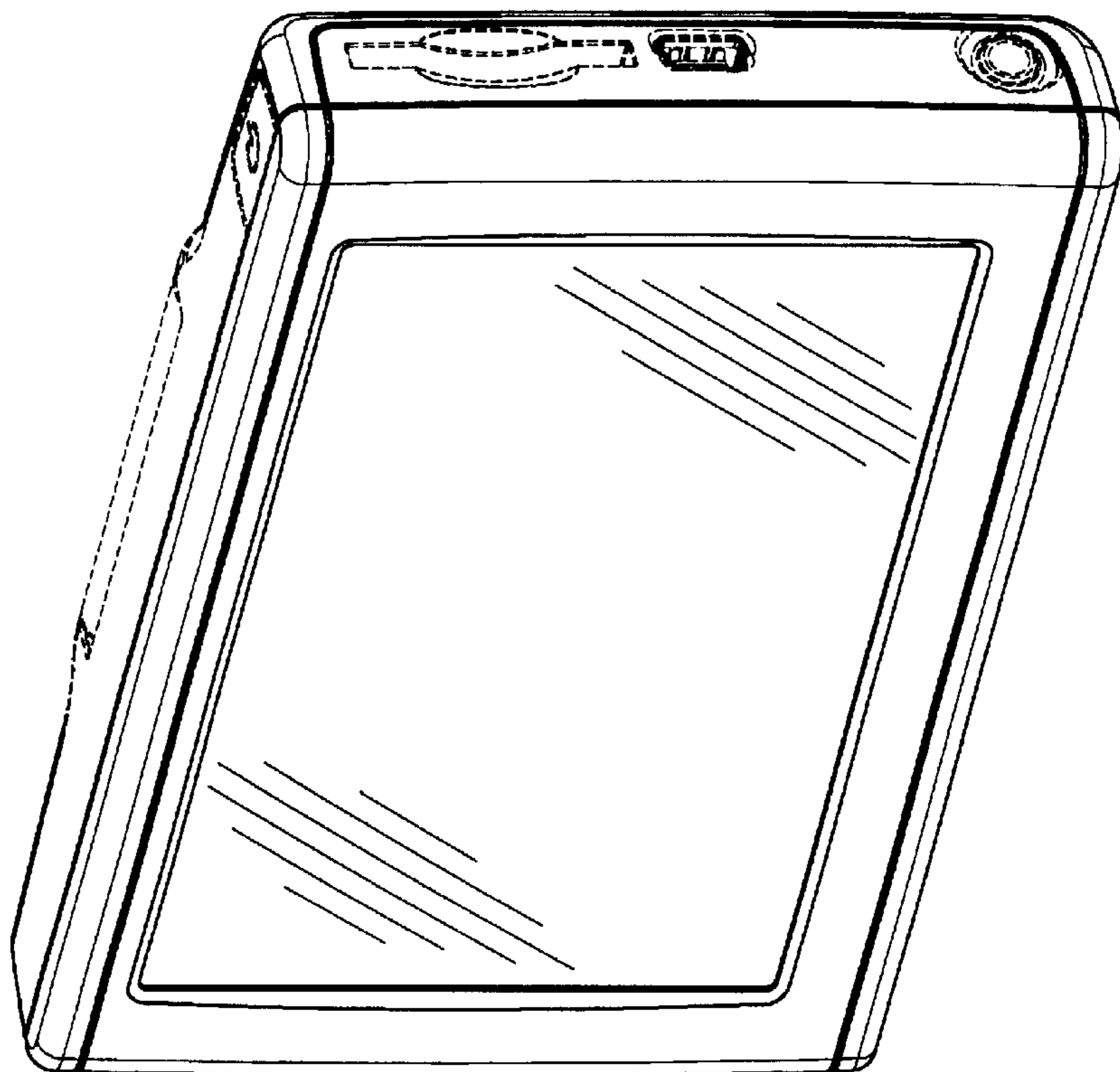

FIG. 1.

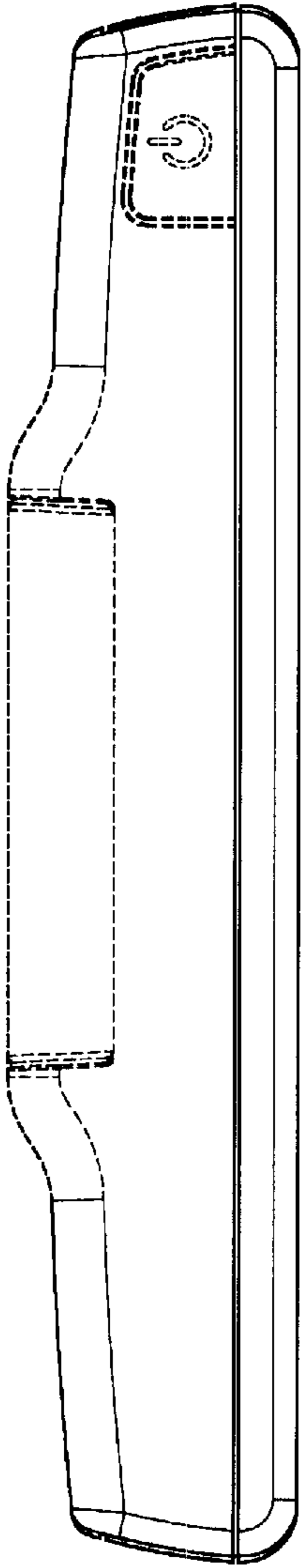

FIG. 4.

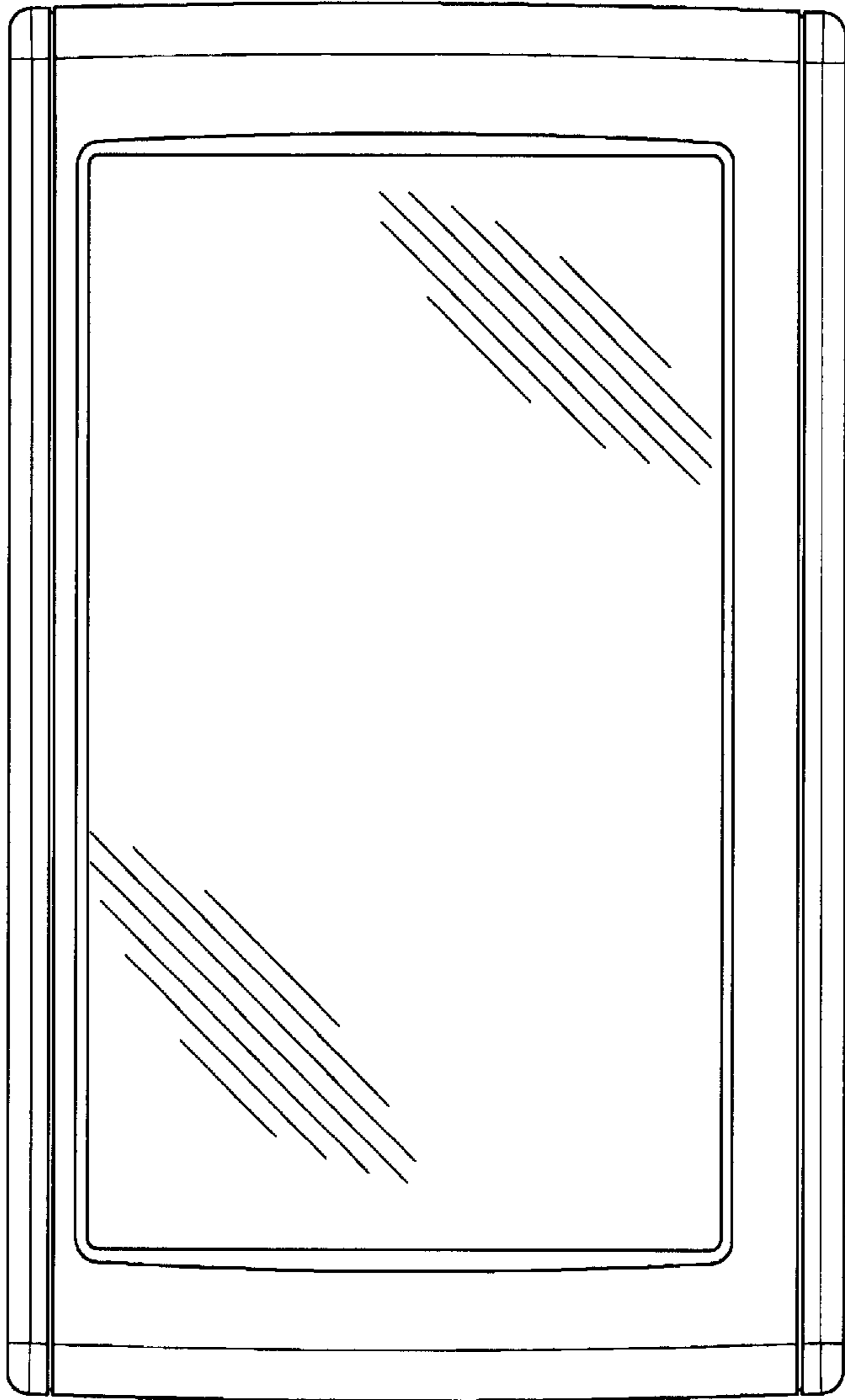
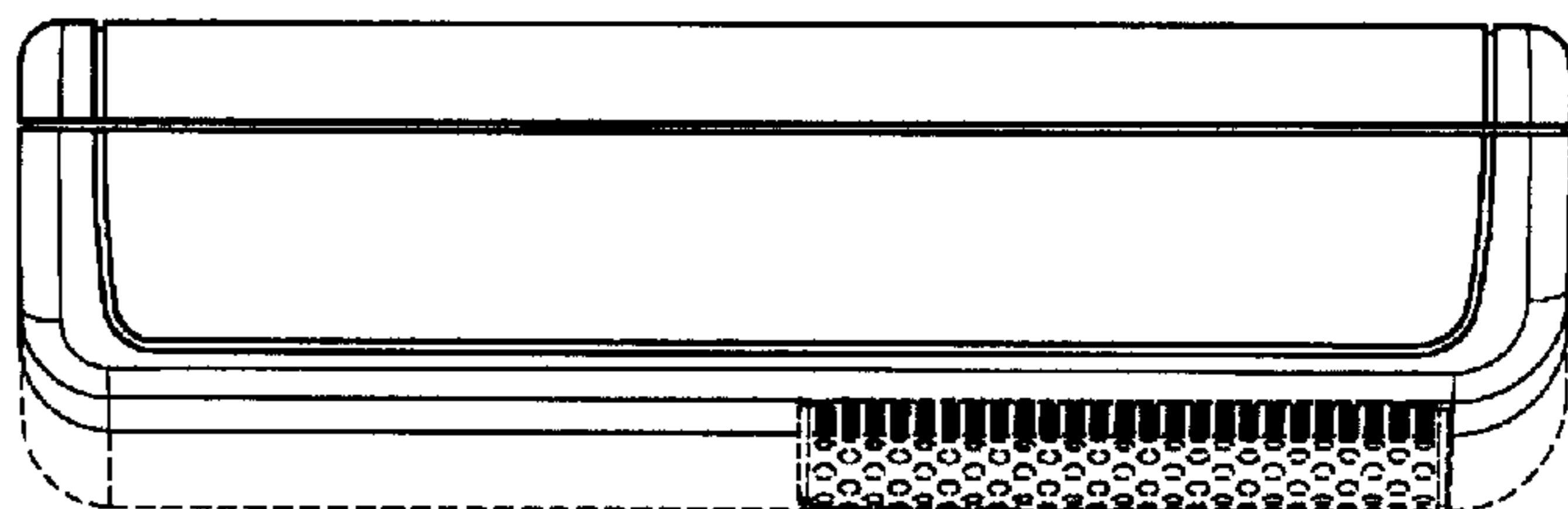

FIG. 3.

FIG. 5.



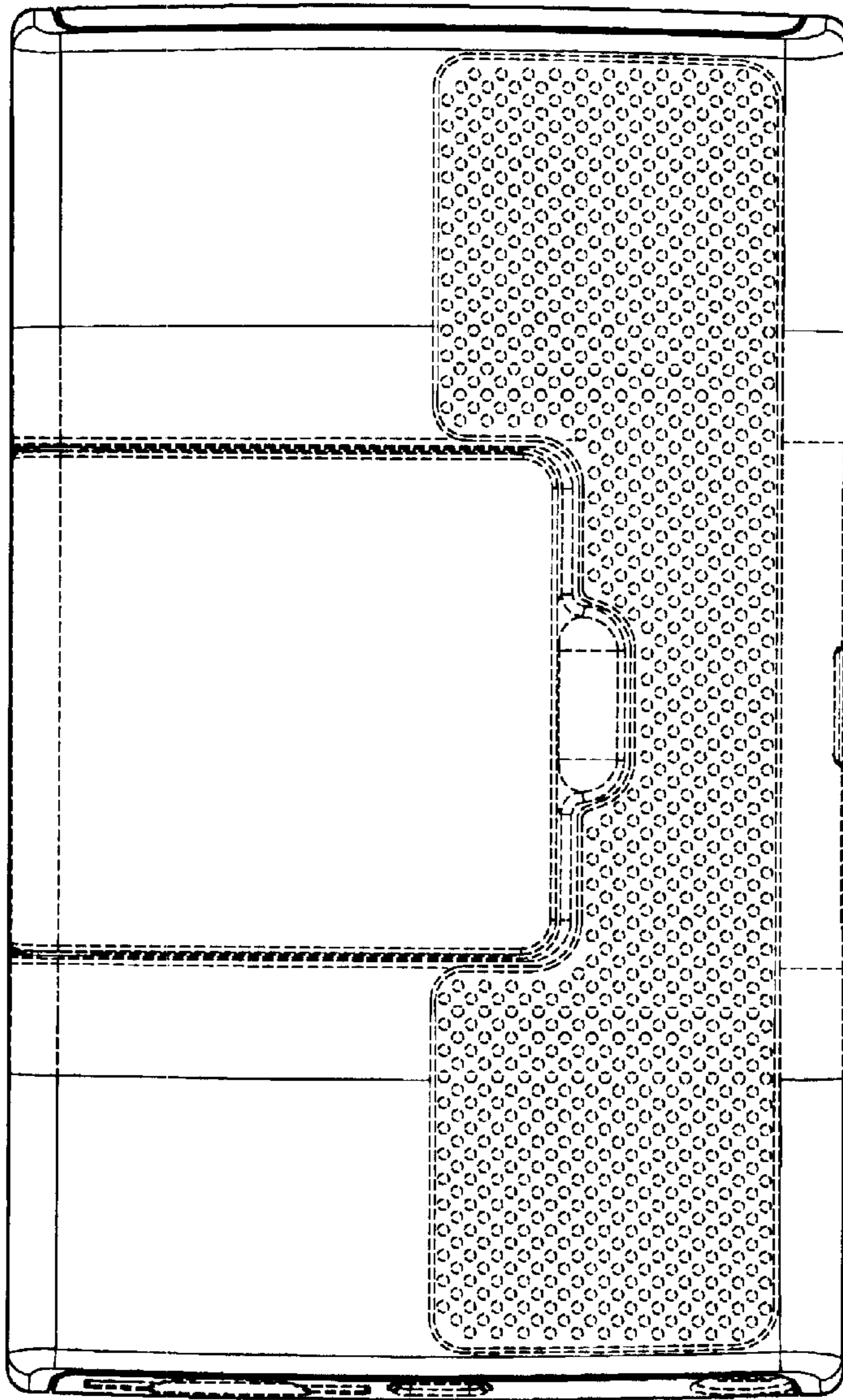

FIG. 6.

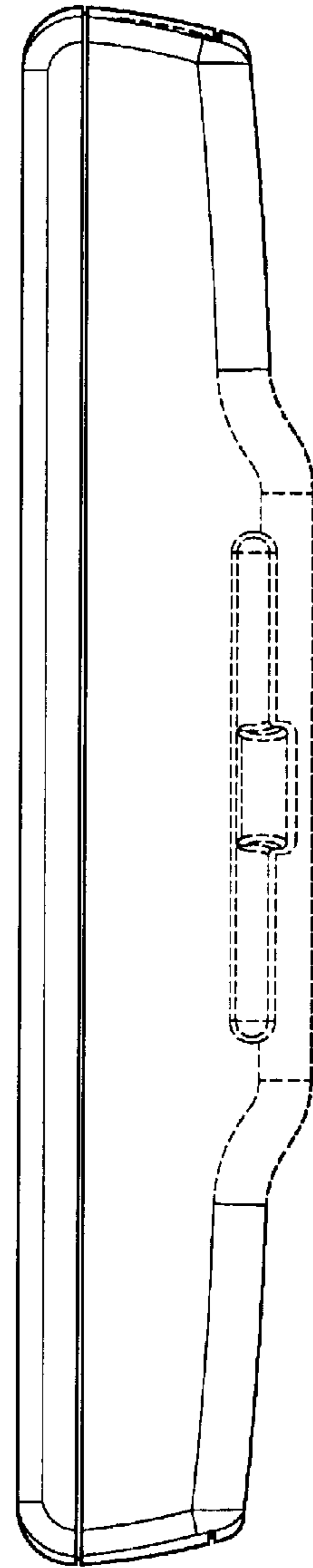

FIG. 7.

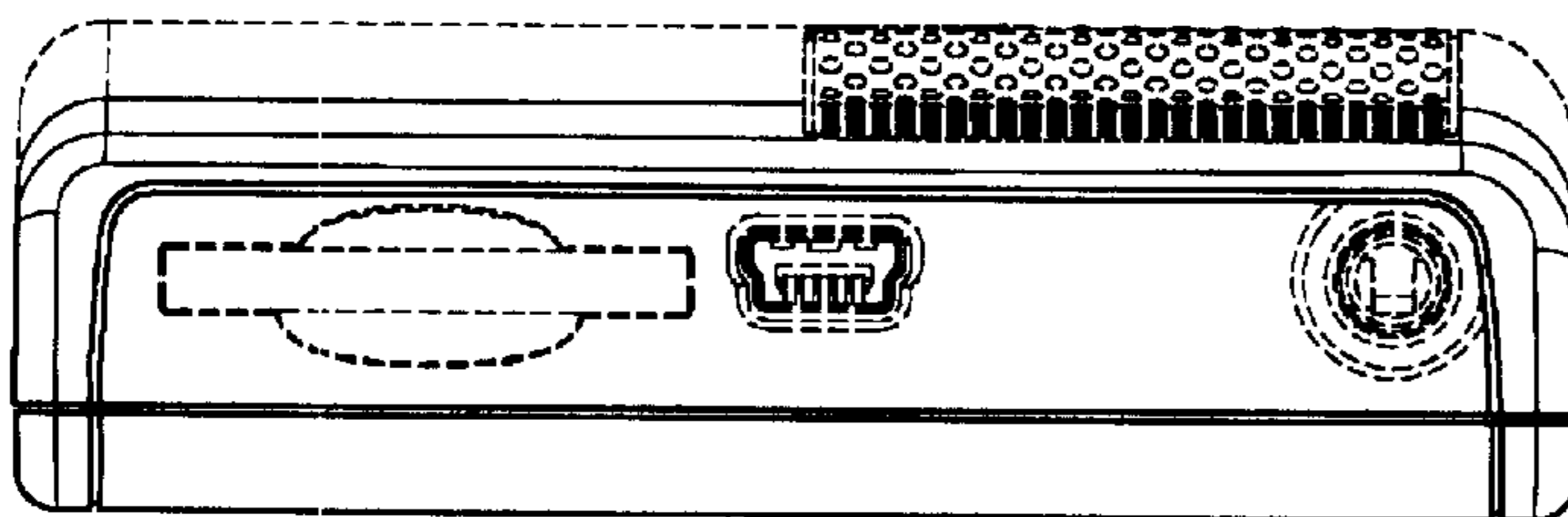

FIG. 8.