



US00D543835S

(12) **United States Design Patent**
Geiger

(10) **Patent No.:** **US D543,835 S**

(45) **Date of Patent:** **** Jun. 5, 2007**

(54) **DUAL SWIVEL SADDLE SPACER**

(75) Inventor: **Gerard G. Geiger**, Jackson, WI (US)

(73) Assignee: **HellermannTyton Corporation**,
Milwaukee, WI (US)

(**) Term: **14 Years**

(21) Appl. No.: **29/230,285**

(22) Filed: **May 19, 2005**

(51) **LOC (8) Cl.** **08-05**

(52) **U.S. Cl.** **D8/354**

(58) **Field of Classification Search** **D8/354;**
24/16 PB; 403/119

See application file for complete search history.

(56) **References Cited**

U.S. PATENT DOCUMENTS

1,313,372	A	8/1919	Dodge
1,437,144	A	11/1922	Isaacson
2,193,291	A	3/1940	Marchins
2,945,713	A	7/1960	Sears
3,149,808	A	9/1964	Weckesser
3,250,505	A	5/1966	Rodman, Sr. et al.
3,486,725	A	12/1969	Hidassy
3,504,937	A	4/1970	Panovic
3,632,070	A	1/1972	Thayer
3,632,071	A	1/1972	Cameron et al.
3,705,708	A	12/1972	Cunningham
3,913,876	A	10/1975	McSherry
4,037,978	A	7/1977	Connelly

(Continued)

FOREIGN PATENT DOCUMENTS

GB	933929	A1	8/1963
GB	2129863		5/1964

OTHER PUBLICATIONS

Thomas & Betts Corporation catalog, p. 3, showing Ty-Rap Cable Tying System, 2000.

Primary Examiner—Holly H. Baynham

(74) *Attorney, Agent, or Firm*—Ryan Kromholz & Manion, S.C.

(57) **CLAIM**

The ornamental design for a dual swivel saddle spacer, as shown and described.

DESCRIPTION

FIG. 1 is a perspective view of a first embodiment of a dual swivel saddle spacer according to the present invention.

FIG. 2 is a perspective view of the spacer of FIG. 1 with the upper portion thereof being rotated 90°.

FIG. 3 is an elevational view taken from either the front or the back of the spacer of FIG. 1.

FIG. 4 is an elevational view of either the left side or the right side of the spacer of FIG. 1.

FIG. 5 is a plan view of either the top or the bottom of the spacer of FIG. 1.

FIG. 6 is a perspective view of a second embodiment of a dual swivel saddle spacer according to the present invention.

FIG. 7 is a perspective view of the spacer of FIG. 6 with the upper portion thereof being rotated 90°.

FIG. 8 is an elevational view taken from either the front or the back of the spacer of FIG. 6.

FIG. 9 is an elevational view of either the left side or the right side of the spacer of FIG. 6; and,

FIG. 10 is a plan view of either the top or the bottom of the spacer of FIG. 6.

1 Claim, 4 Drawing Sheets

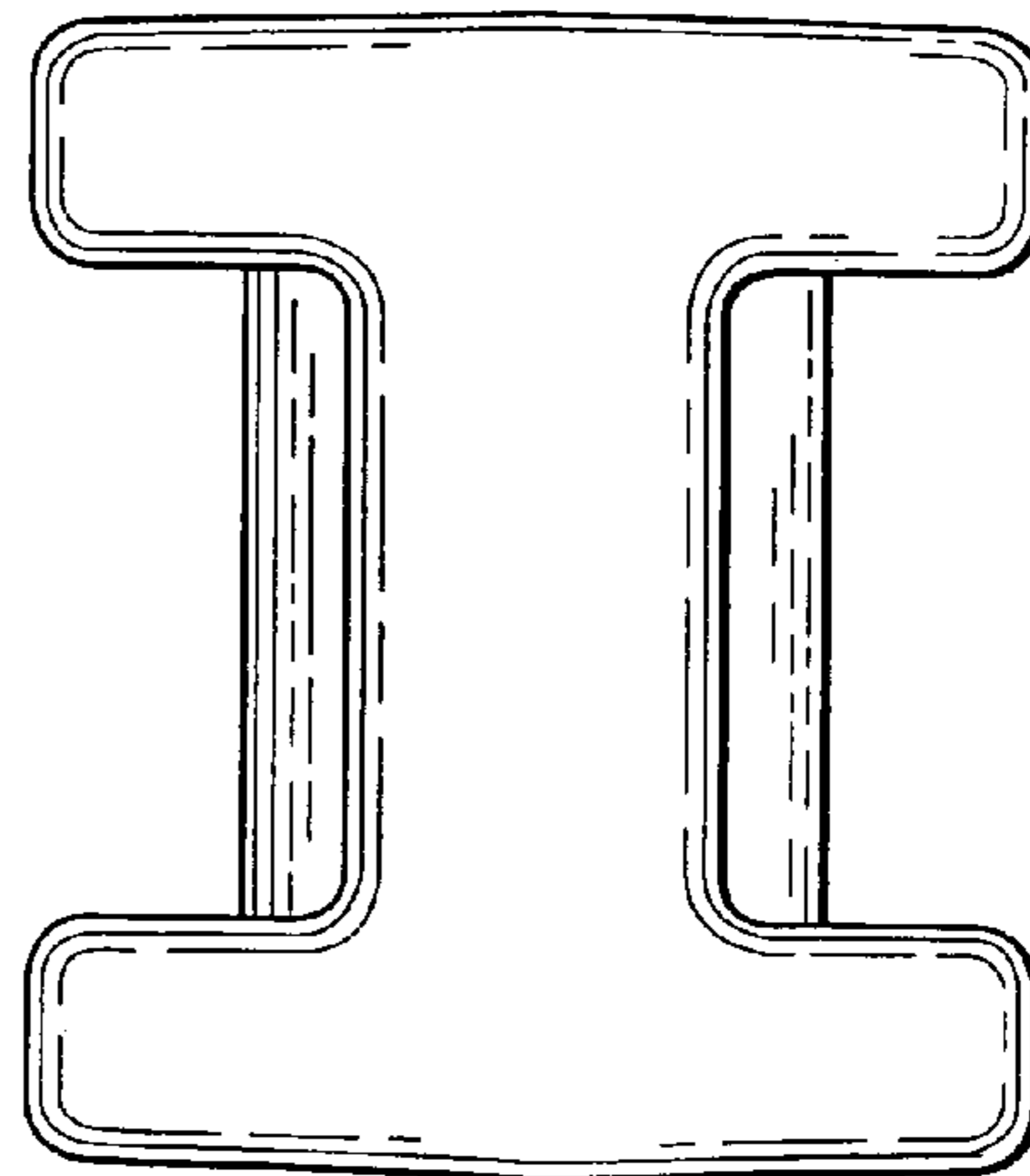
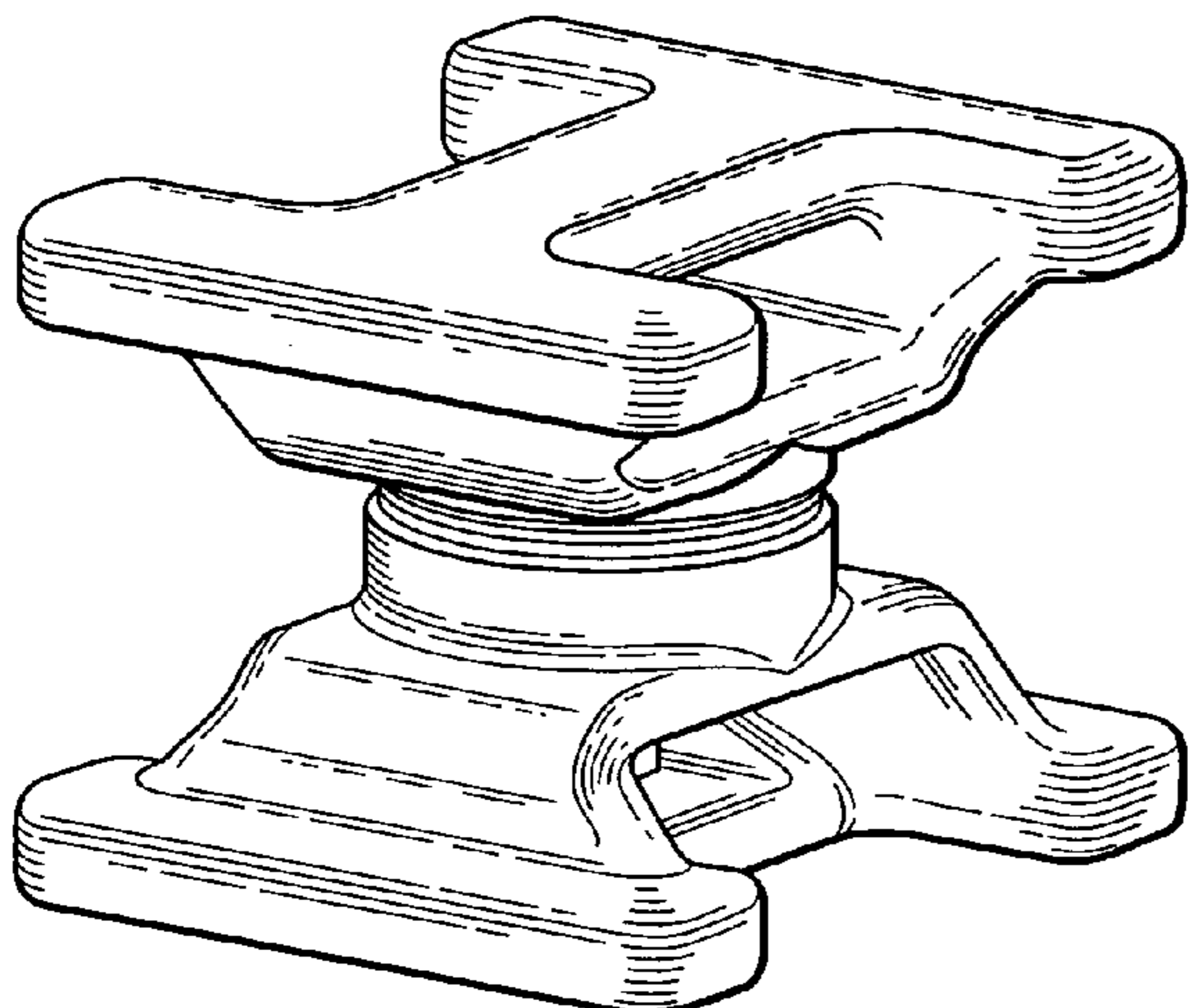

US D543,835 S

Page 2

U.S. PATENT DOCUMENTS							
4,128,220	A	12/1978	McNeel	5,636,937	A	6/1997	Zemlicka
4,141,116	A	2/1979	Zalonis	5,653,409	A	8/1997	White, Jr. et al.
4,396,329	A	8/1983	Wollar	5,730,399	A	3/1998	Baginski
4,552,481	A	11/1985	Bluett	5,732,915	A *	3/1998	Heard 248/219.4
4,665,588	A	5/1987	Nakano	5,820,048	A	10/1998	Shereyk et al.
4,688,961	A	8/1987	Shioda et al.	5,862,927	A	1/1999	Tebeau
4,705,245	A	11/1987	Osada	5,884,367	A	3/1999	Teagno et al.
4,768,741	A	9/1988	Logsdon	5,966,781	A	10/1999	Geiger
4,865,281	A	9/1989	Wollar	6,196,751	B1	3/2001	Khokhar
4,925,136	A	5/1990	Knott	6,240,602	B1	6/2001	Geiger
4,936,530	A	6/1990	Wollar	6,398,169	B1	6/2002	Streit
4,955,749	A	9/1990	Panovic	6,457,210	B1 *	10/2002	Shirai et al. 24/16 PB
5,224,244	A	7/1993	Ikeda et al.	6,533,226	B2	3/2003	Geiger
5,328,290	A	7/1994	Plastina	6,536,718	B2	3/2003	Benito-Navazo
5,332,179	A	7/1994	Kuffel et al.	6,718,597	B2	4/2004	Geiger
5,337,983	A	8/1994	Mailey	2002/0071715	A1	6/2002	Geiger
5,386,615	A	2/1995	Bernard	2002/0109050	A1	8/2002	Winton, III
5,538,208	A	7/1996	Cordes et al.	2003/0189140	A1	10/2003	Takeuchi

* cited by examiner

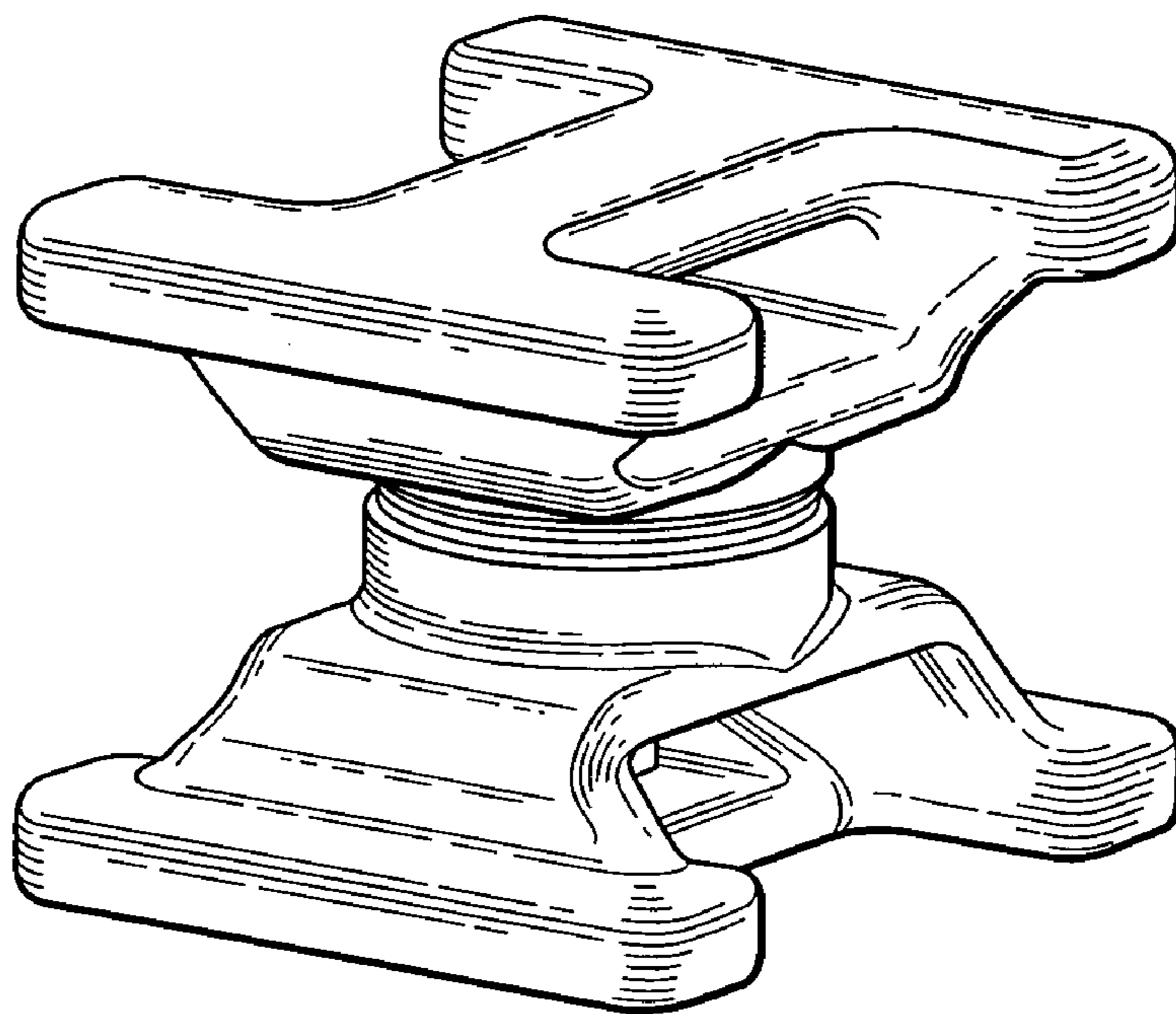

Fig. 1

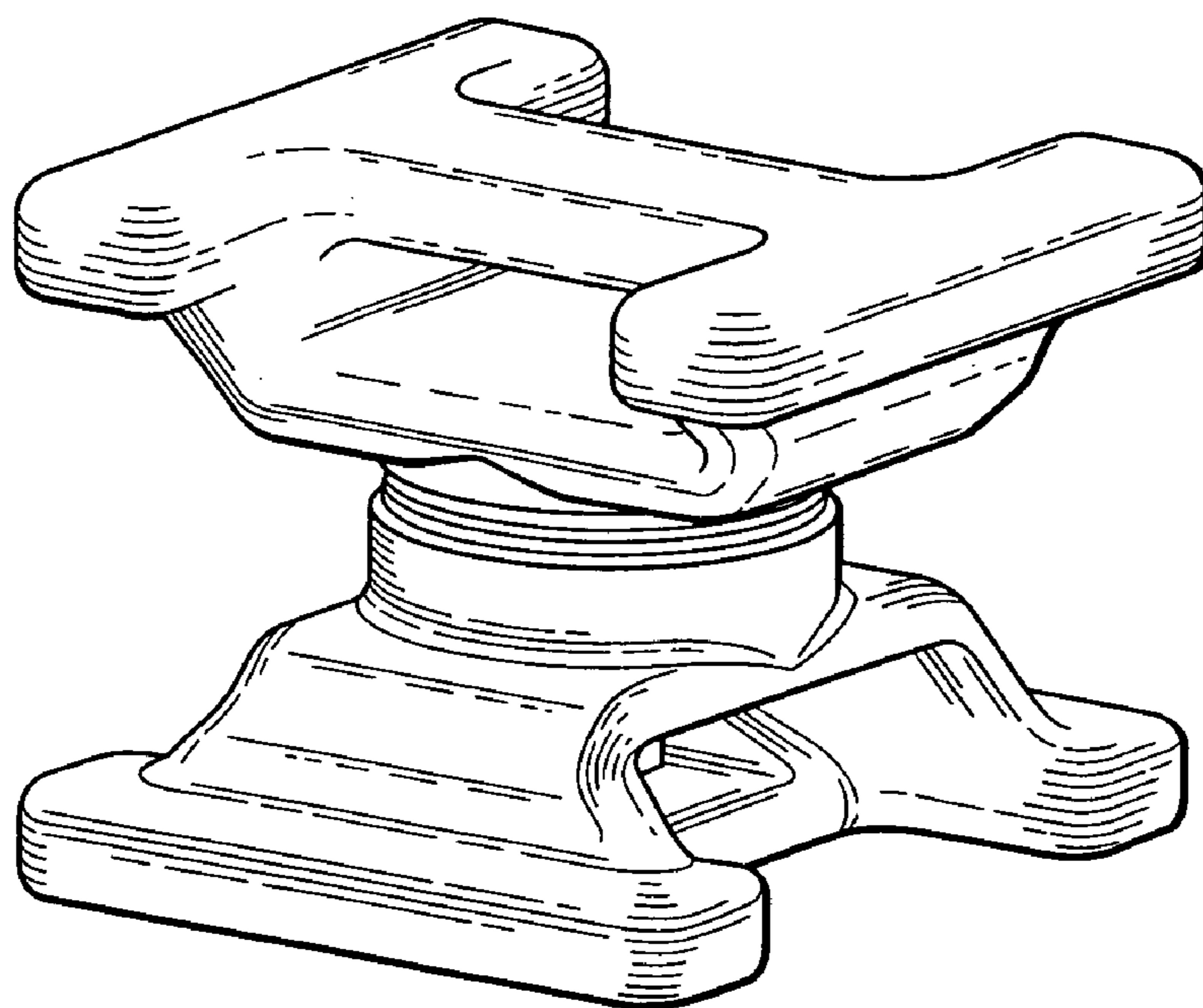

Fig. 2

Fig. 3

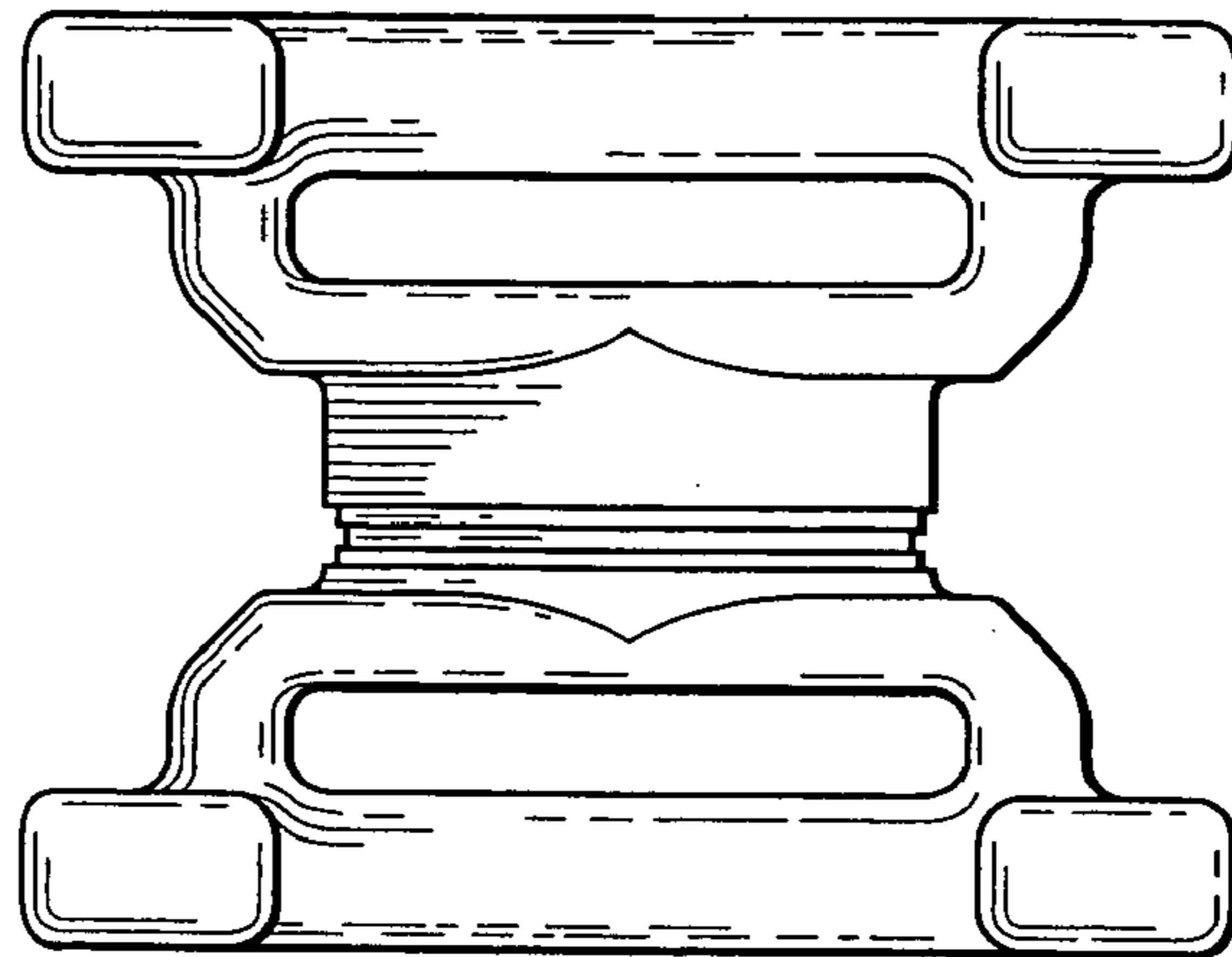

Fig. 4

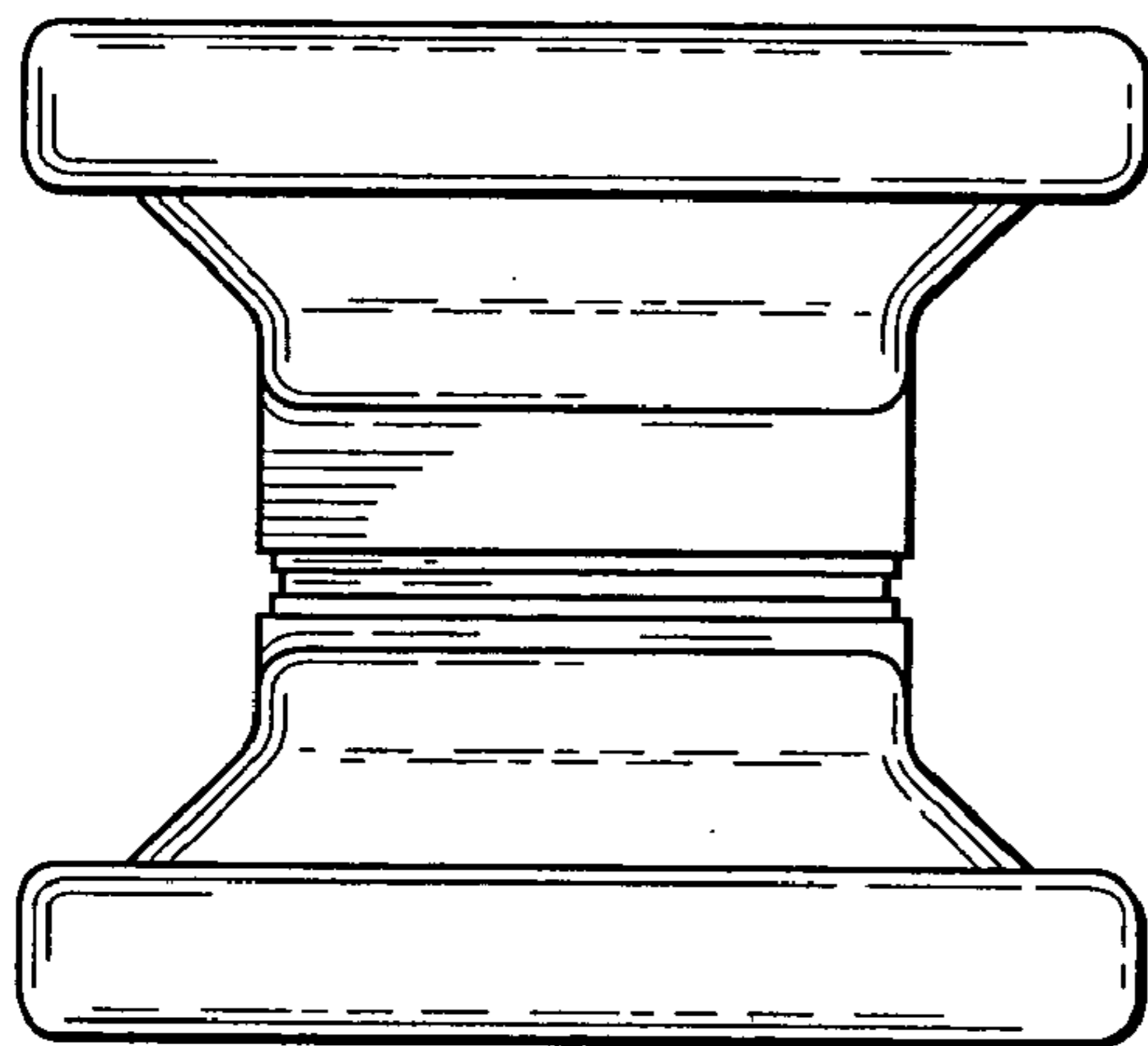
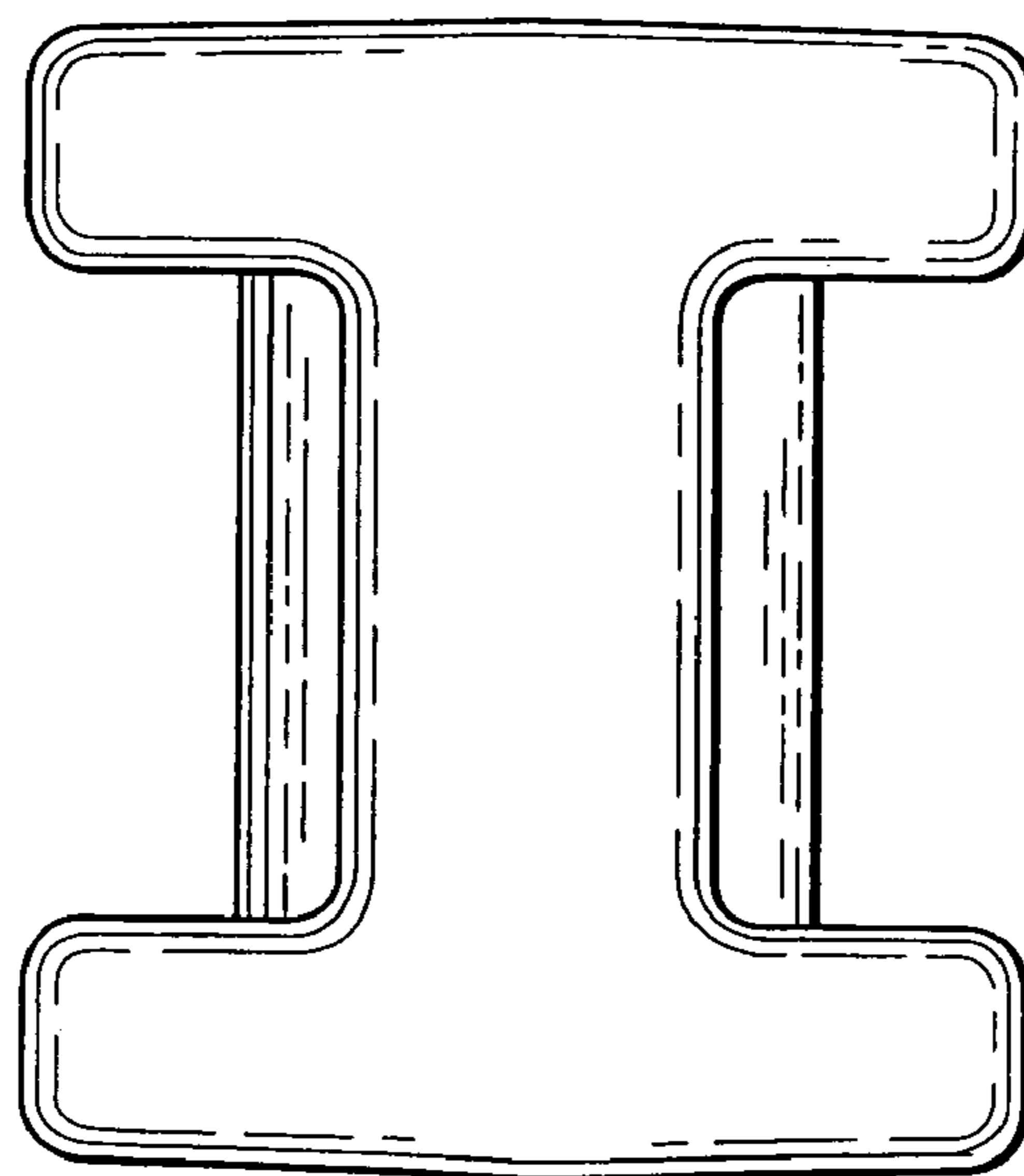

Fig. 5



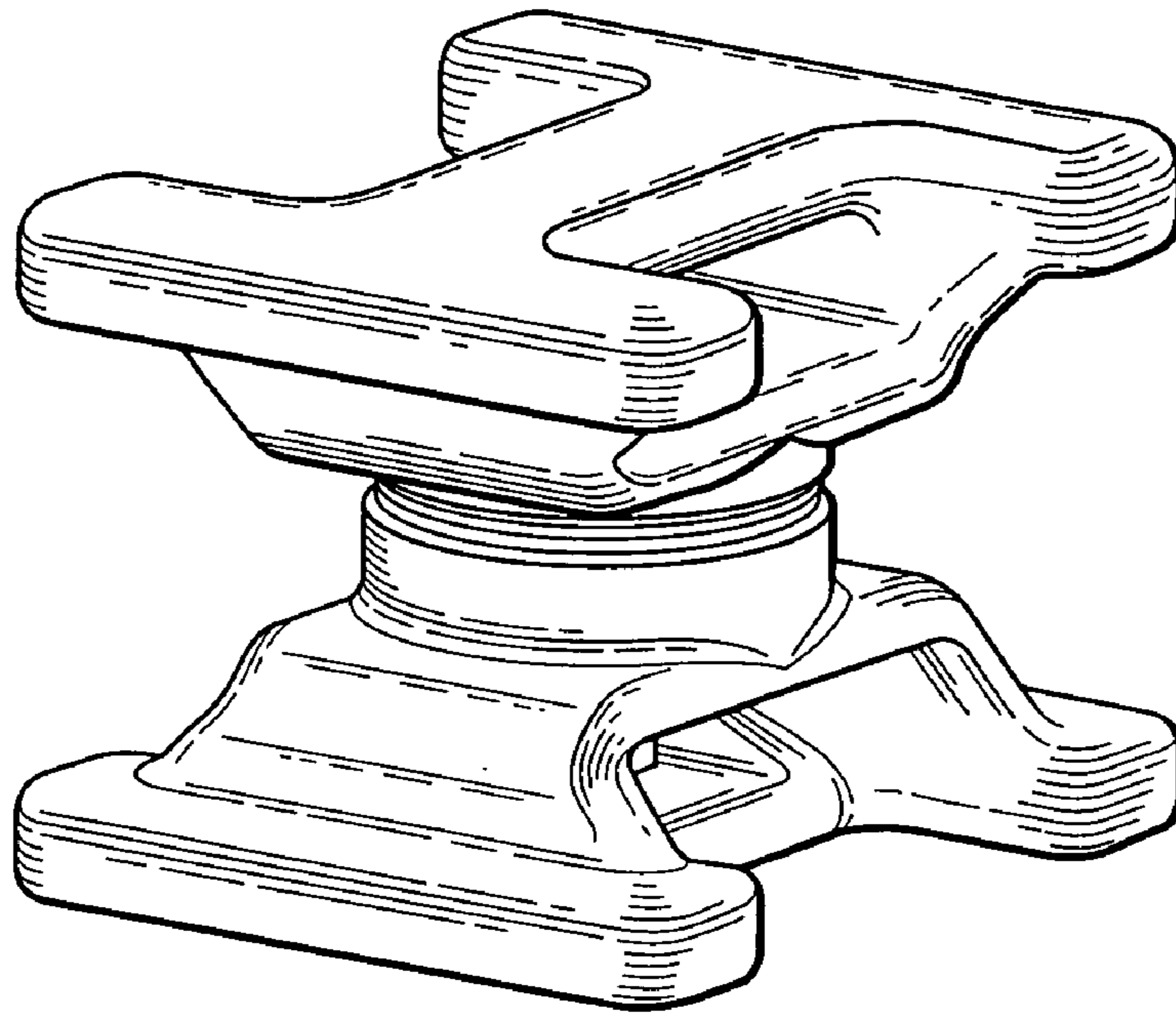

Fig. 6

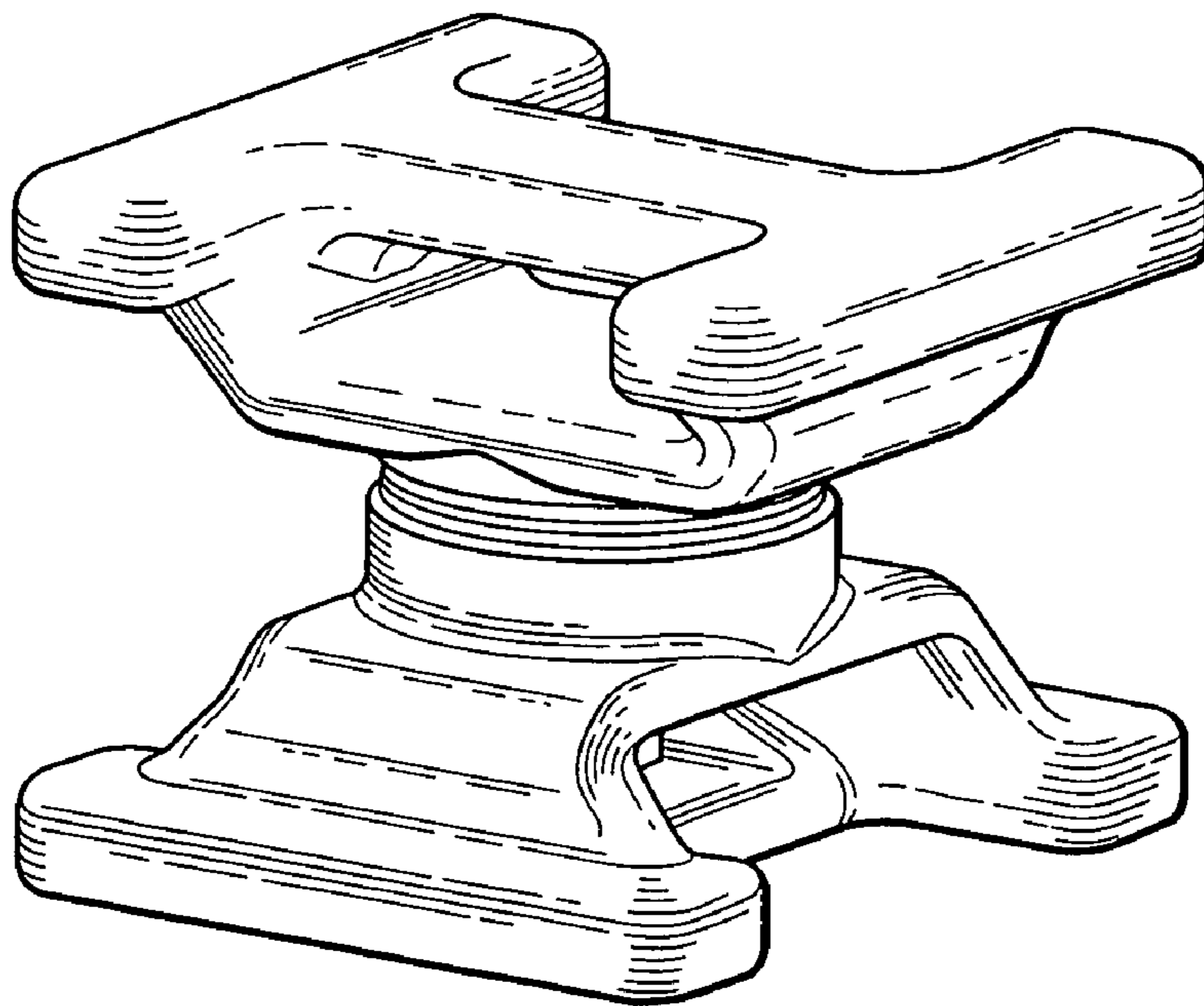

Fig. 7

Fig. 8

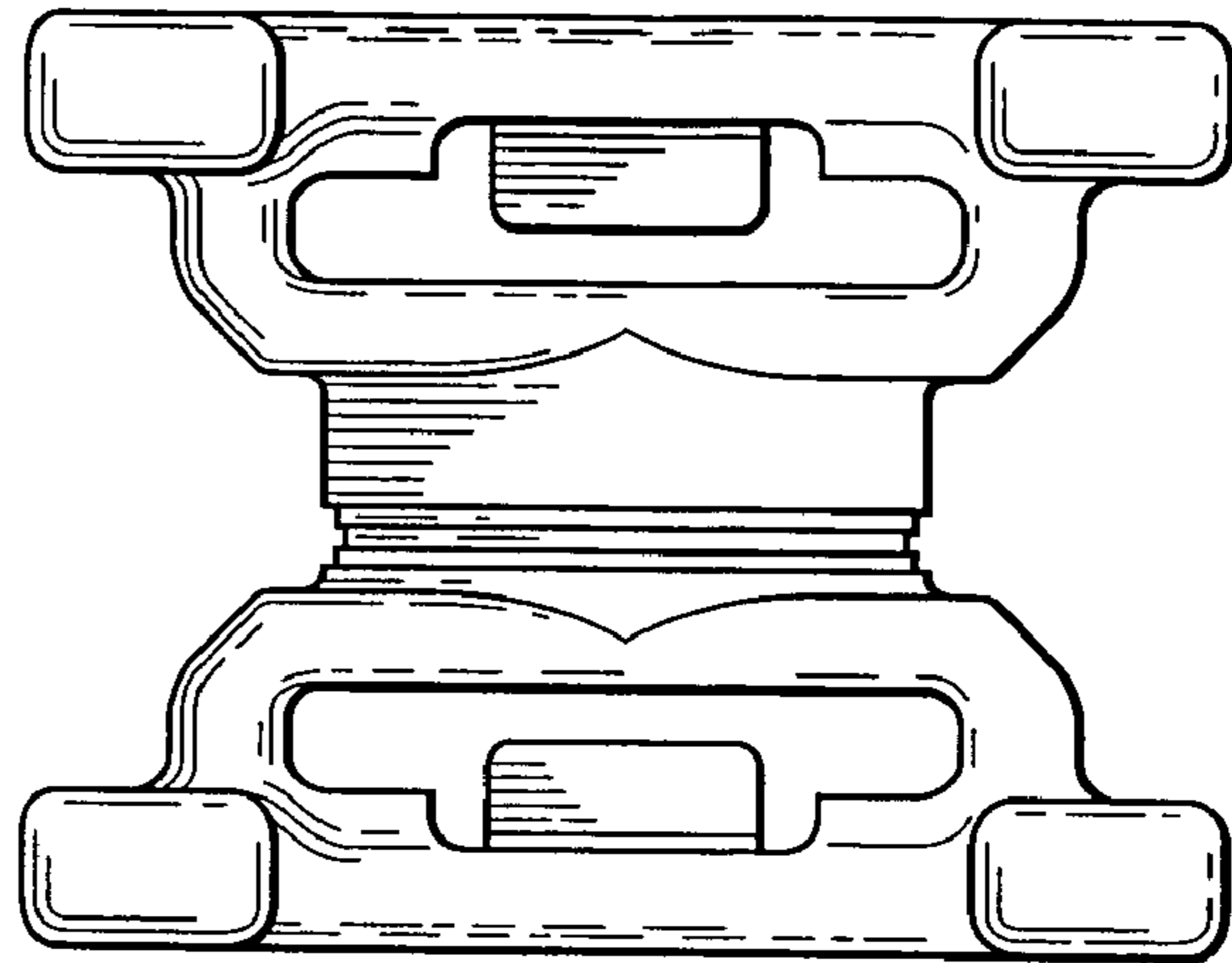

Fig. 9

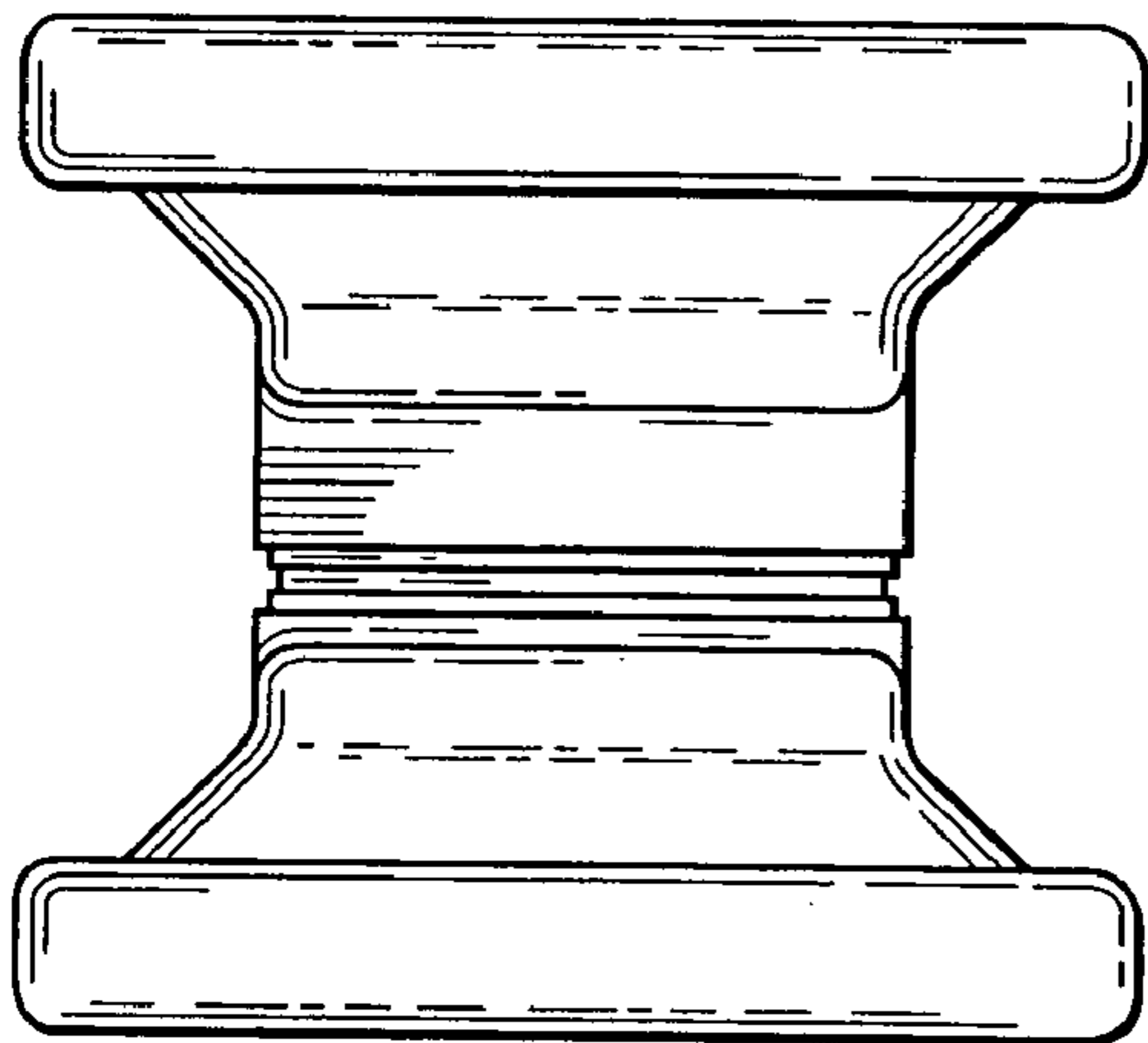

Fig. 10

