



US00D543489S

(12) **United States Design Patent**
Gunby

(10) **Patent No.:** **US D543,489 S**

(45) **Date of Patent:** **** May 29, 2007**

(54) **TRANSPORTER**

(57) **CLAIM**

(76) Inventor: **William Gunby**, 2740 SW. Martin
Downs Blvd. #251, Palm City, FL (US)
34990

The ornamental design for a transporter, as shown and described.

(**) Term: **14 Years**

DESCRIPTION

(21) Appl. No.: **29/246,396**

(22) Filed: **Apr. 7, 2006**

(51) **LOC (8) Cl.** **12-08**

(52) **U.S. Cl.** **D12/98**

(58) **Field of Classification Search** D12/98,
D12/93; 296/181.2, 181.3

See application file for complete search history.

FIG. 1 is a perspective view of the transporter as viewed from the left, front side of the transporter, with an environment of use of the transporter shown in broken lines for illustrative purposes and not forming part of the claimed design;

FIG. 2 is a left side elevation view of the transporter the transporter, , with an environment of use of the transporter shown in broken lines for illustrative purposes and not forming part of the claimed design;

FIG. 3 is a top view of the transporter, with an environment of use of the transporter shown in broken lines for illustrative purposes and not forming part of the claimed design;

FIG. 4 is a front elevation view of the transporter, with an environment of use of the transporter shown in broken lines for illustrative purposes and not forming part of the claimed design; and,

FIG. 5 is a rear elevation view of the transporter, with an environment of use of the transporter shown in broken lines for illustrative purposes and not forming part of the claimed design.

(56) **References Cited**

U.S. PATENT DOCUMENTS

D430,068 S *	8/2000	Castiglione et al.	D12/98
D500,461 S *	1/2005	Noguchi et al.	D12/98
D508,440 S *	8/2005	Hall et al.	D12/98
D515,462 S *	2/2006	Metros et al.	D12/98
D516,957 S *	3/2006	O'Connell et al.	D12/98
D517,449 S *	3/2006	Depeyster et al.	D12/98

* cited by examiner

Primary Examiner—Melody N. Brown

(74) *Attorney, Agent, or Firm*—Connolly Bove Lodge & Hutz, LLP; Larry J. Hume

1 Claim, 4 Drawing Sheets

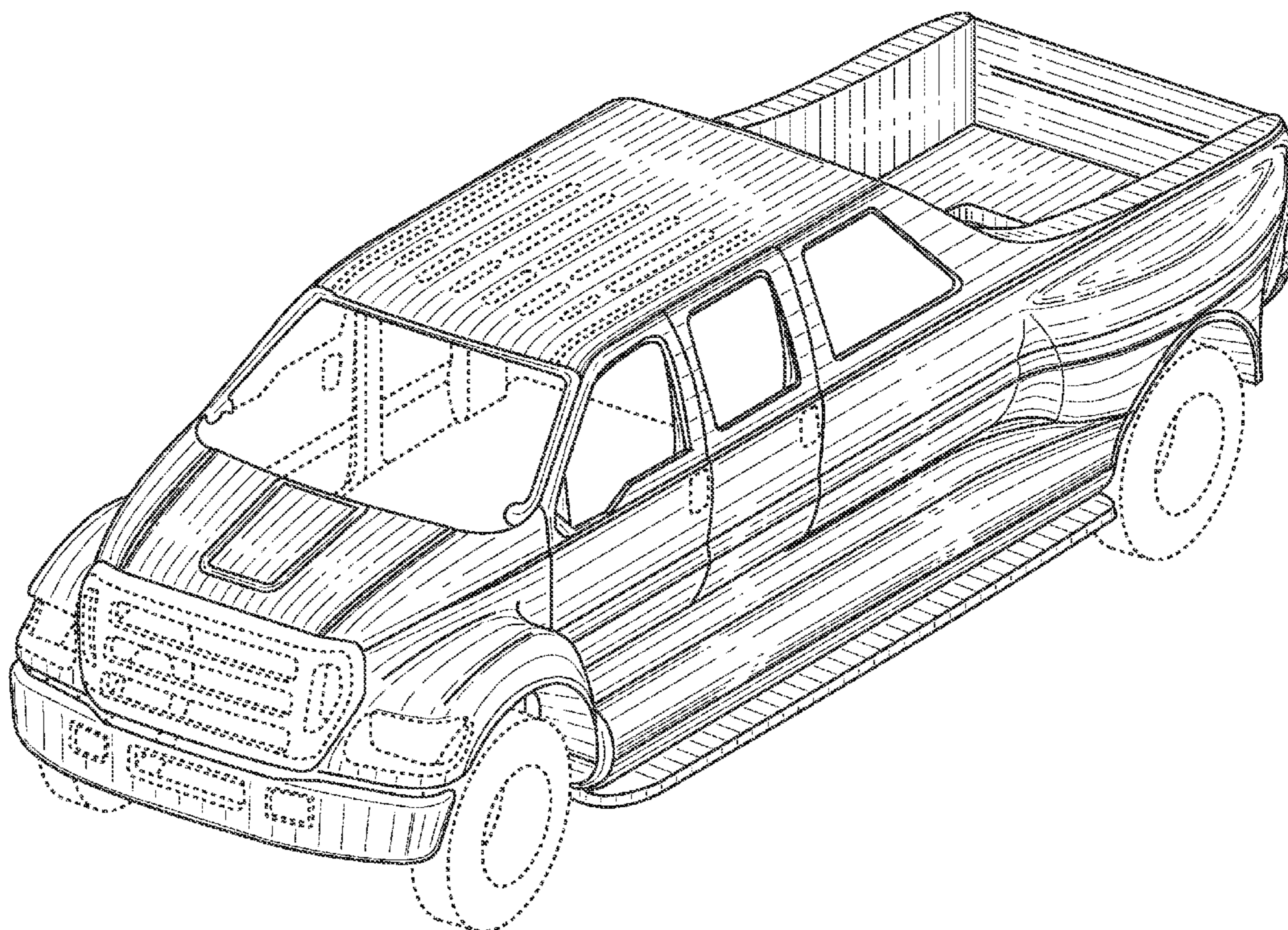

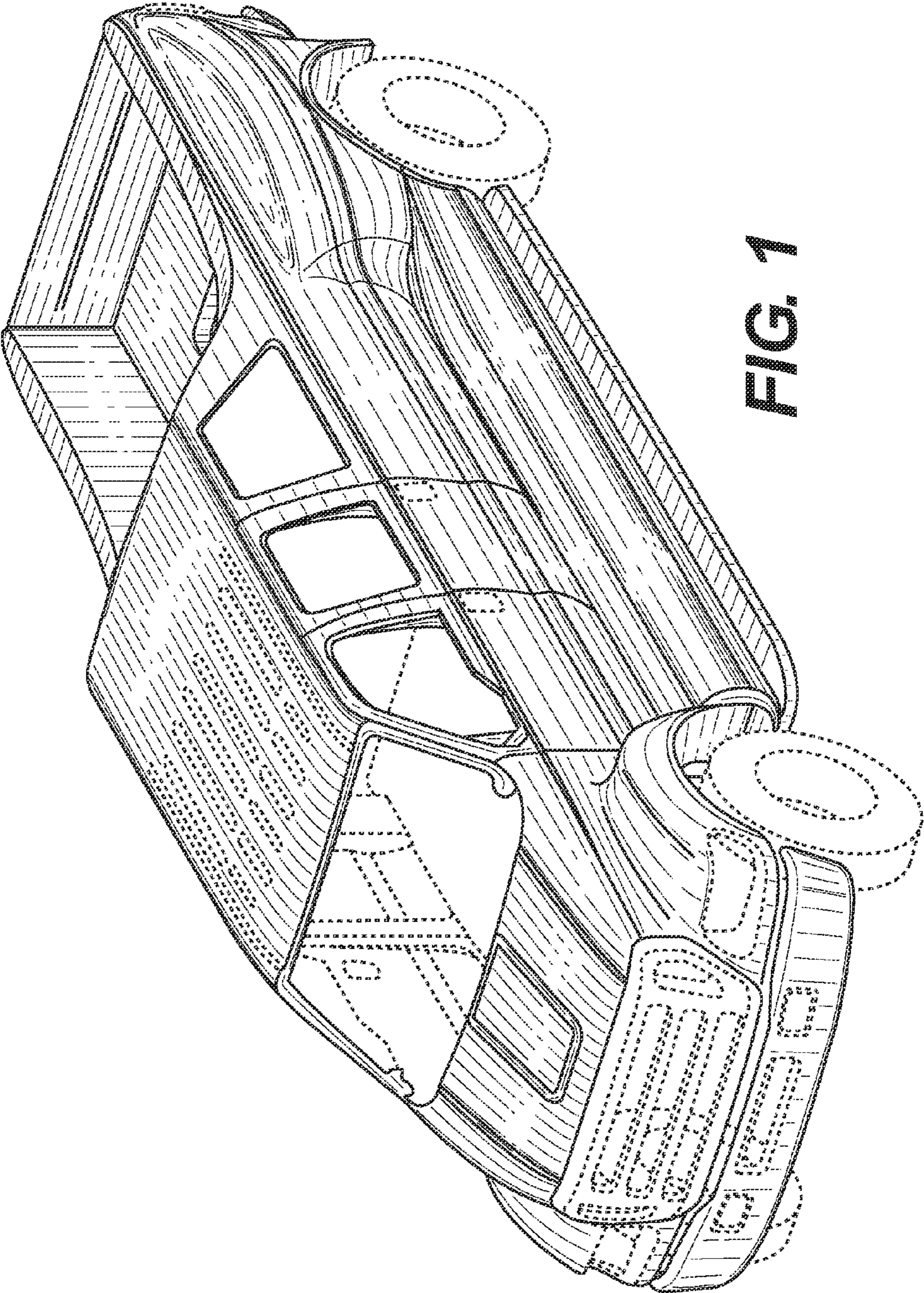

FIG. 1

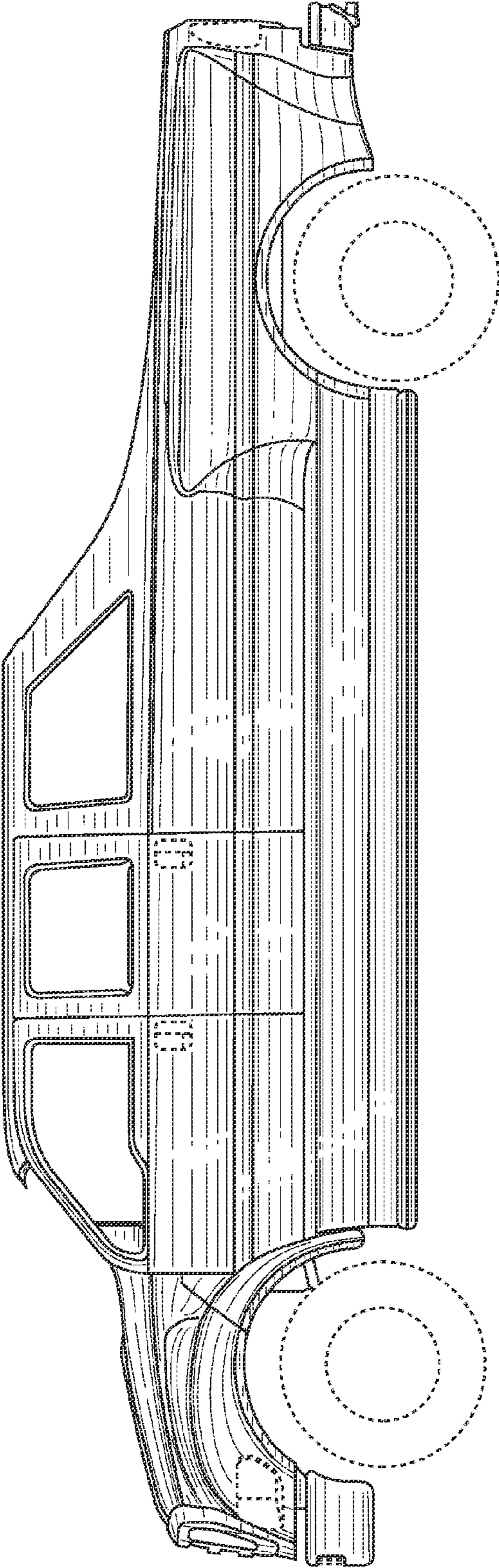

FIG. 2

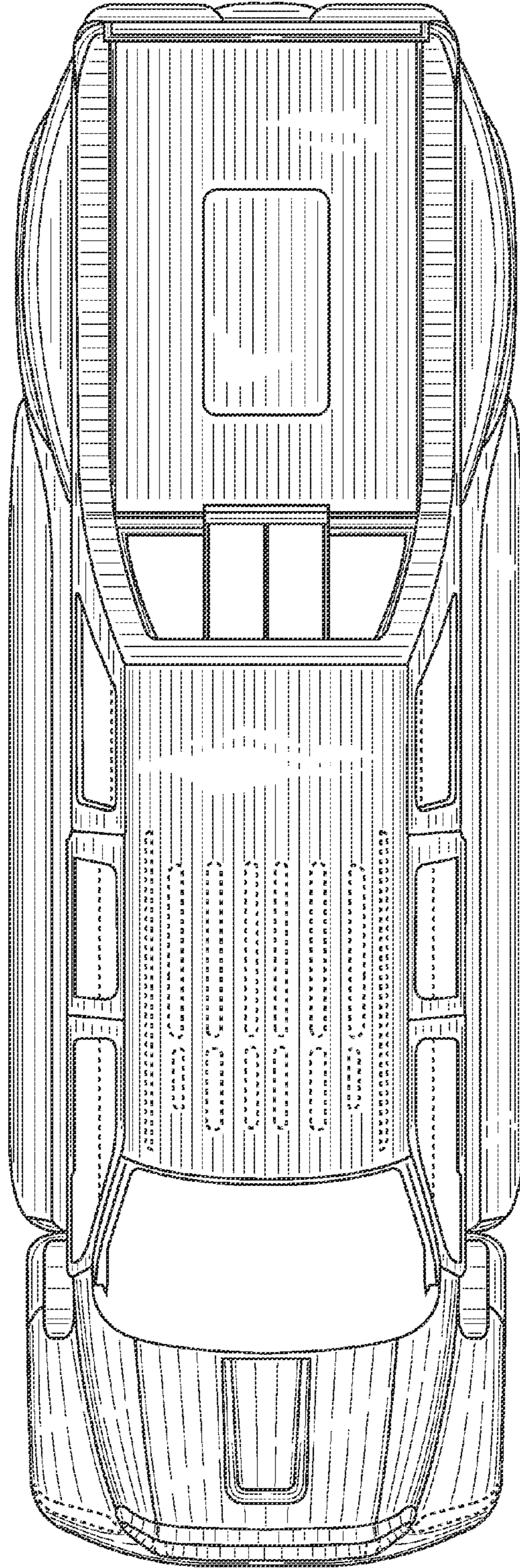

FIG. 3

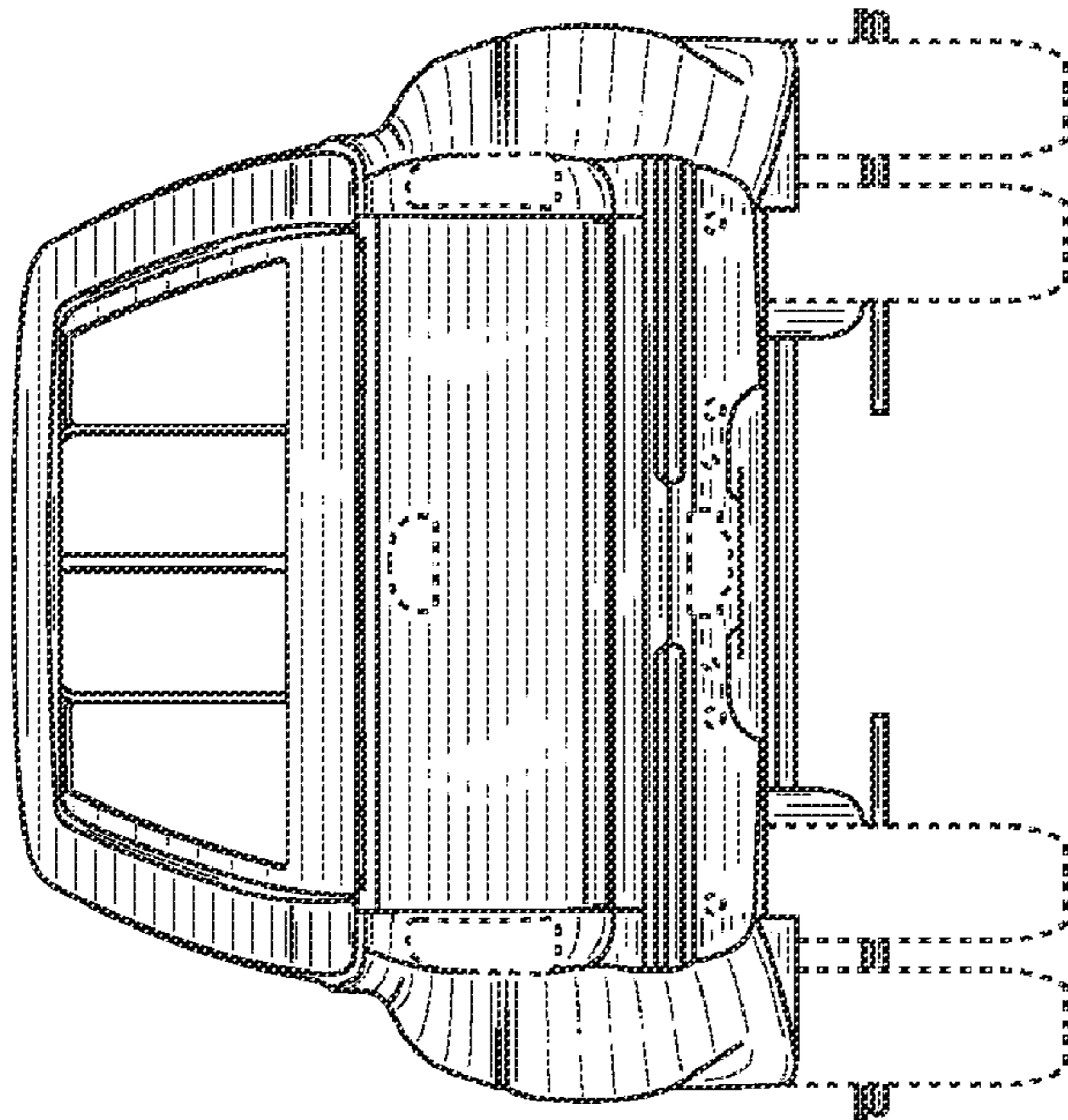

FIG. 5

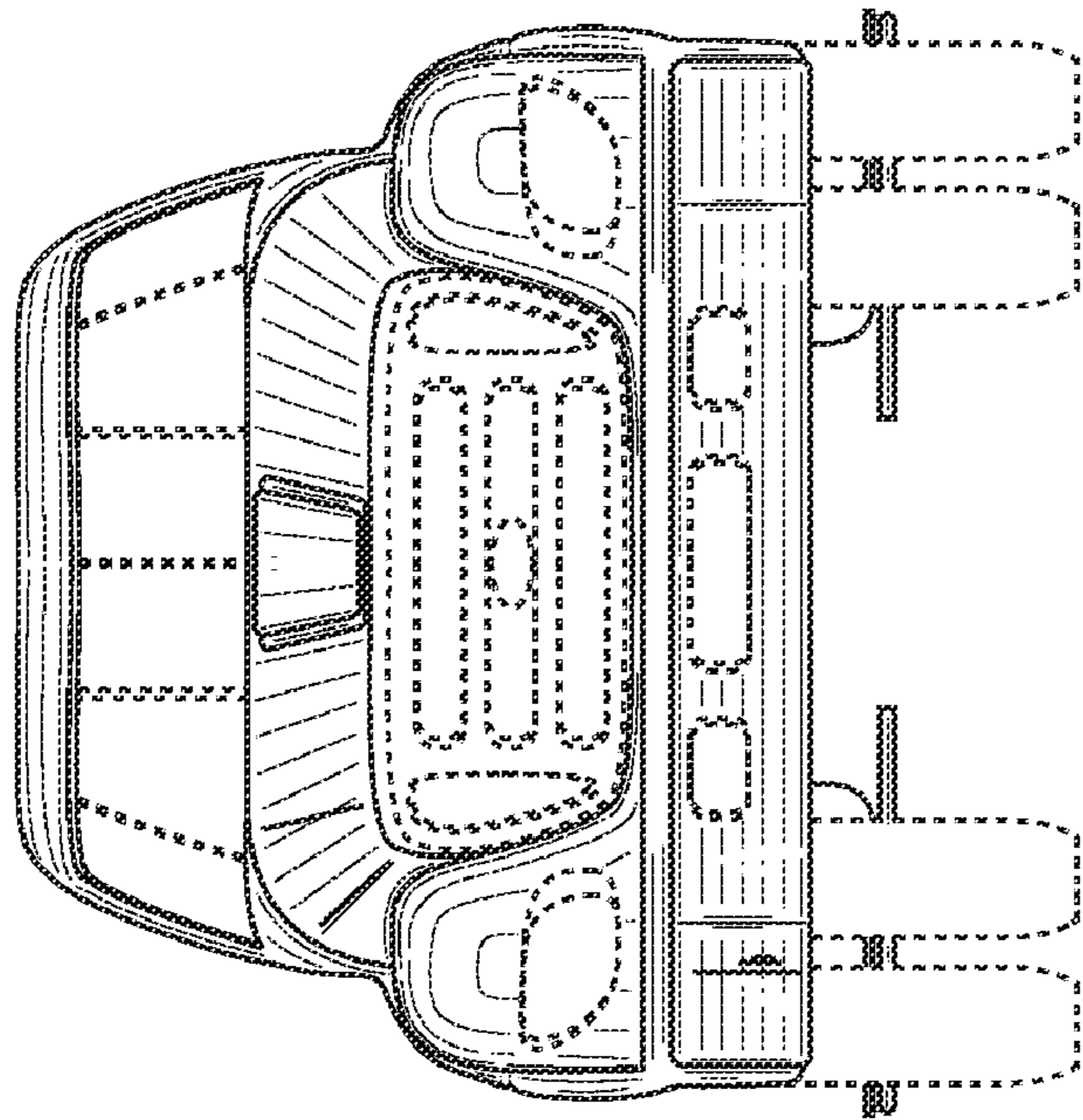

FIG. 4