

US00D543314S

(12) **United States Design Patent**
Morgandi

(10) **Patent No.:** **US D543,314 S**

(45) **Date of Patent:** **** May 22, 2007**

(54) **HAIR IRON**

D515,738 S * 2/2006 Grassi D28/35
D526,087 S * 8/2006 Seizer D28/35

(75) Inventor: **Arturo Morgandi**, Azzano S. Paolo (IT)

* cited by examiner

(73) Assignee: **Imetec S.p.A.**, Bergamo (IT)

Primary Examiner—Jennifer Rivard

(74) *Attorney, Agent, or Firm*—Sughrue Mion, PLLC

(**) Term: **14 Years**

(57) **CLAIM**

(21) Appl. No.: **29/252,207**

The ornamental design for a hair iron, as shown and described.

(22) Filed: **Jan. 20, 2006**

DESCRIPTION

(30) **Foreign Application Priority Data**

Jul. 20, 2005 (EM) 000375126

(51) **LOC (8) Cl.** **28-03**

(52) **U.S. Cl.** **D28/35**

(58) **Field of Classification Search** D28/35–38;
219/222, 225; 132/223–269

See application file for complete search history.

FIG. 1 is a perspective view of the top, one side and one end of a hair iron showing my new design;

FIG. 2 is a perspective view of the top, opposite side and said one end thereof;

FIG. 3 is a top plan view thereof;

FIG. 4 is a bottom plan view thereof;

FIG. 5 is an end elevational view of an opposite end thereof;

FIG. 6 is an end elevational view of said one end thereof; and,

FIG. 7 is an elevational view of said one side, the opposite side being a mirror image thereof.

The broken lines are shown for illustrative purposes only and form no part of the claimed design.

(56) **References Cited**

U.S. PATENT DOCUMENTS

D489,484 S * 5/2004 Cheung D28/35
D511,023 S * 10/2005 Cho D28/35
D514,252 S * 1/2006 Shin D28/35

1 Claim, 5 Drawing Sheets

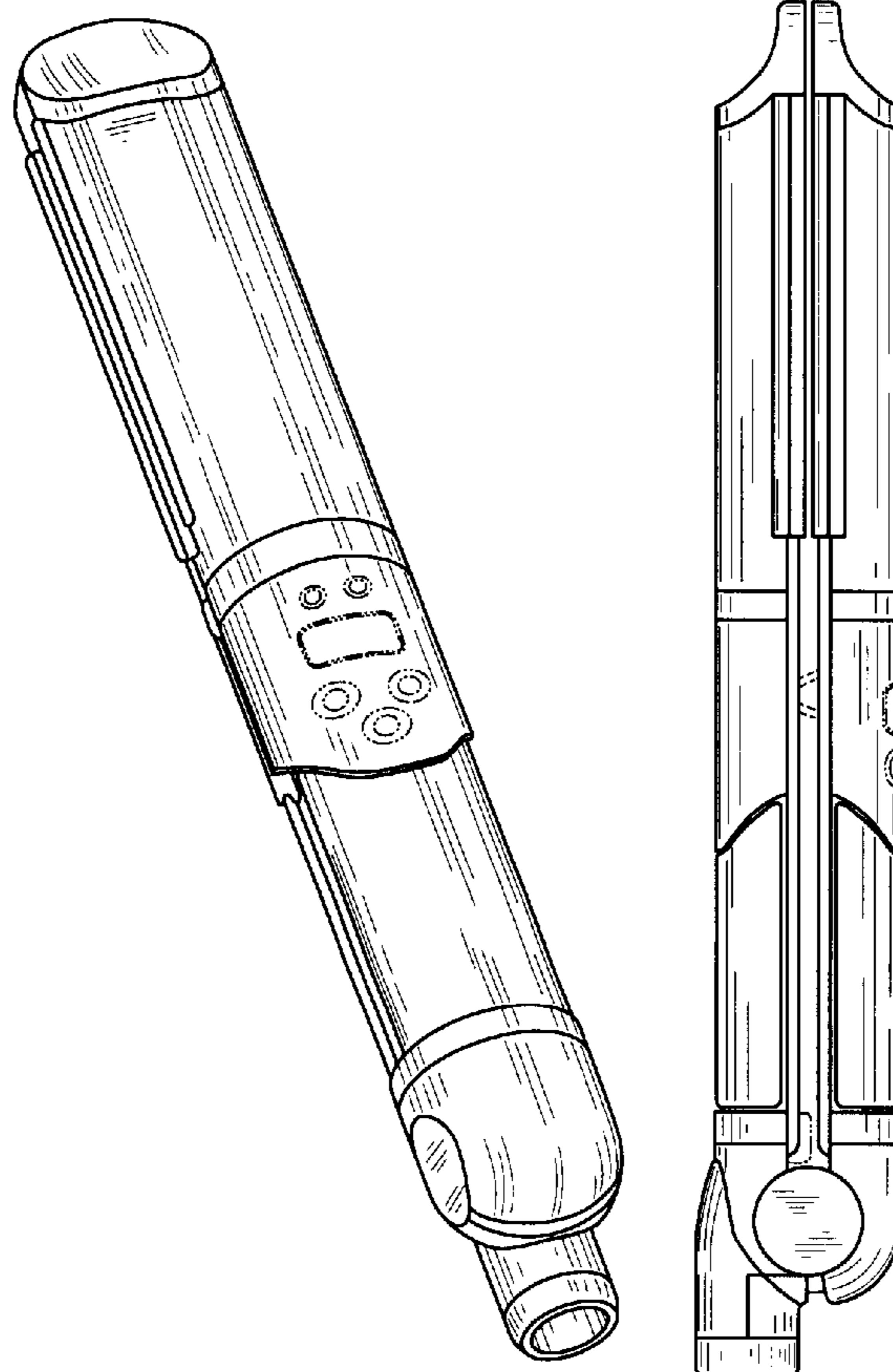

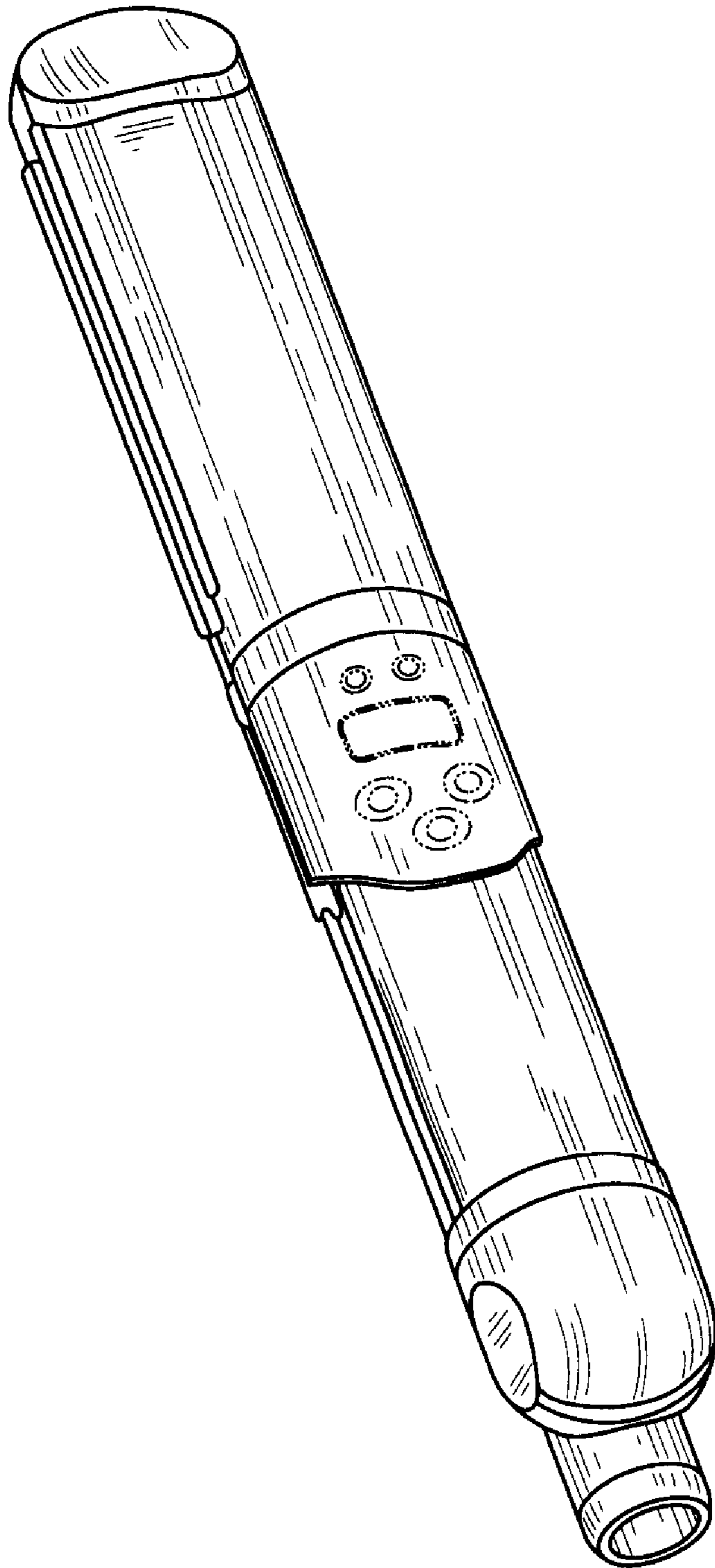

Fig. 1

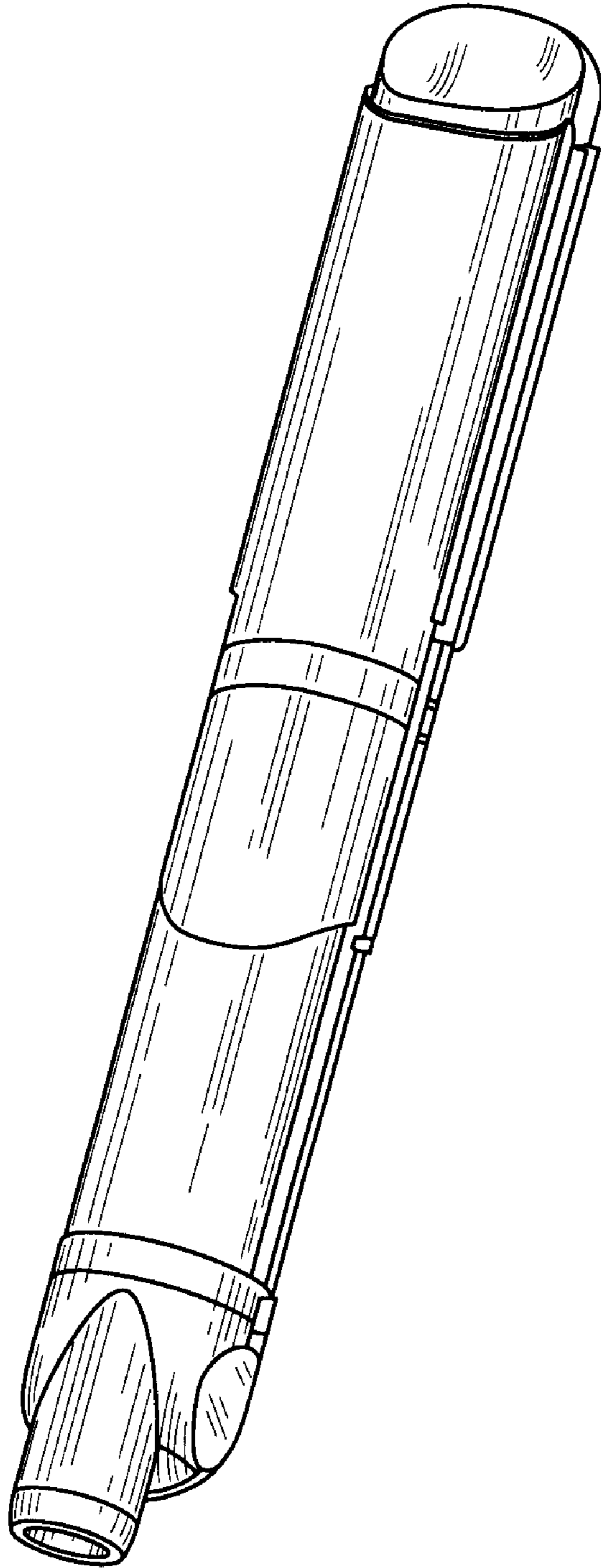

Fig. 2

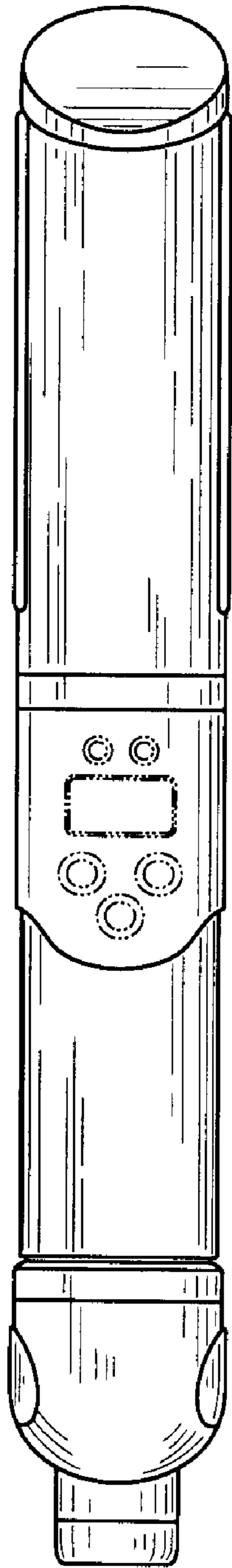

Fig. 3

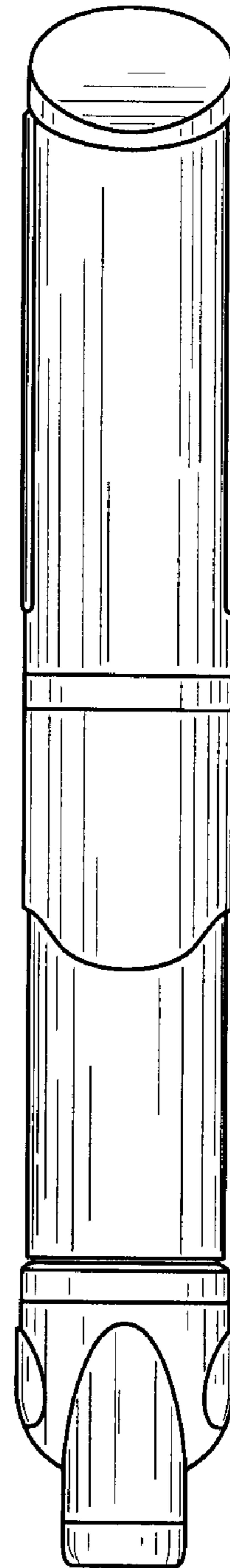

Fig. 4

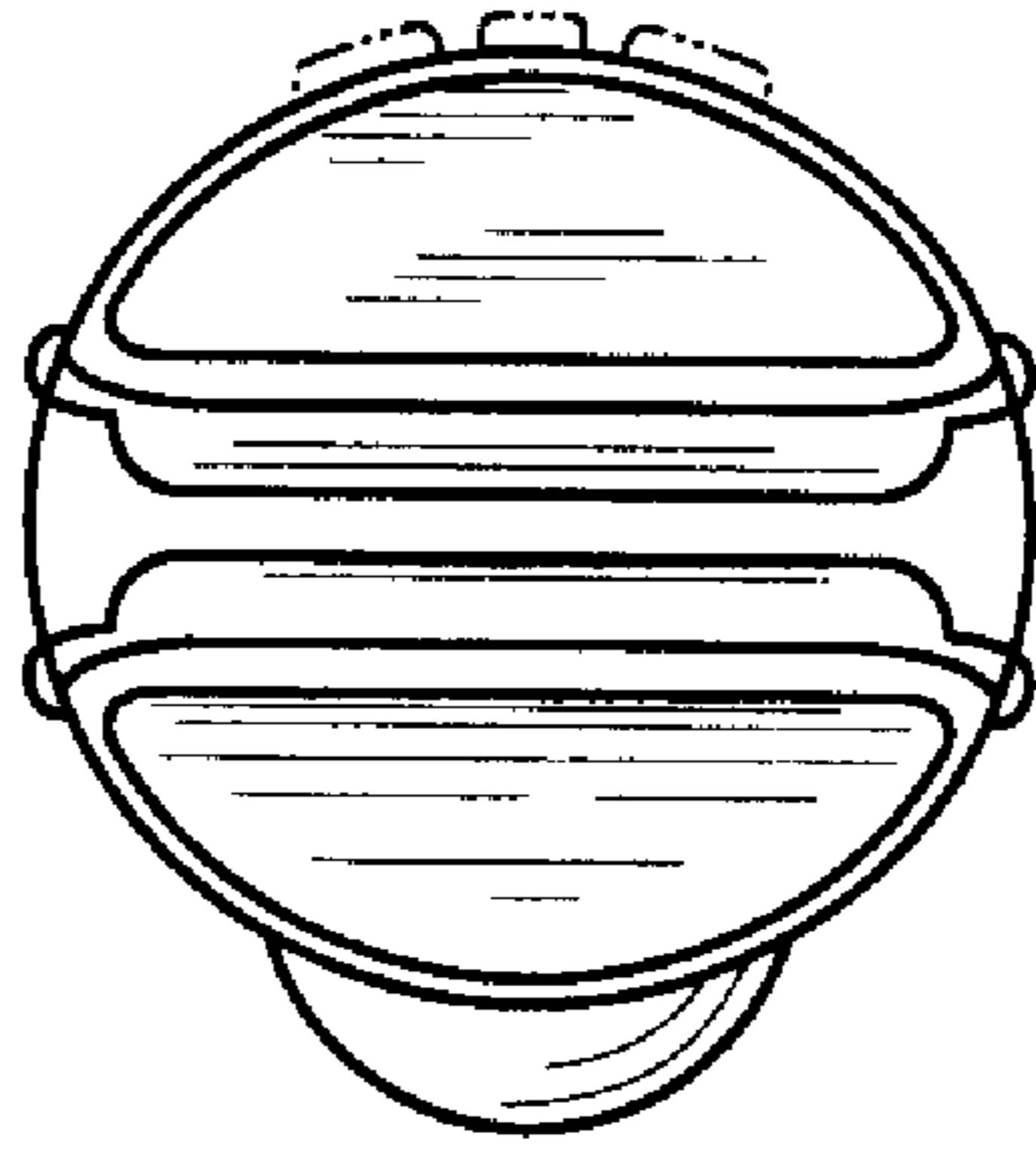

Fig. 5

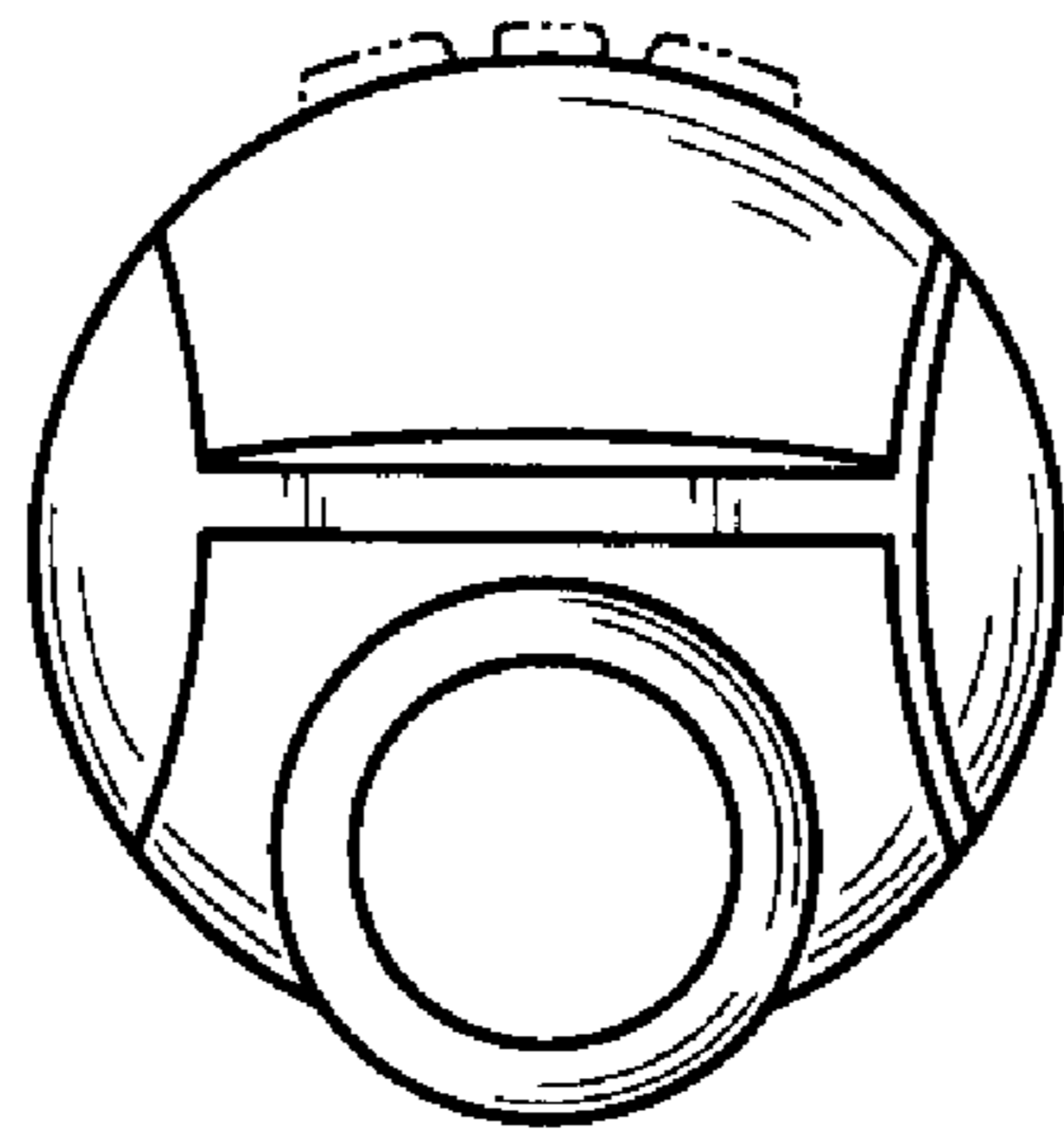

Fig. 6

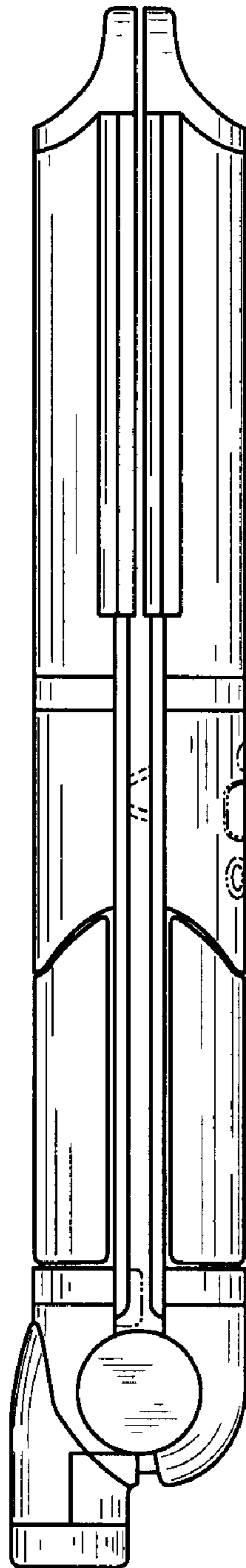

Fig. 7