

US00D543135S

(12) **United States Design Patent**
Trostle et al.

(10) **Patent No.:** **US D543,135 S**
(45) **Date of Patent:** **** May 22, 2007**

(54) **AUTOMOTIVE VEHICLE AND/OR TOY
REPLICA THEREOF**

FOREIGN PATENT DOCUMENTS

(75) Inventors: **D. Mark Trostle**, Plymouth, MI (US);
Christopher C. Dowdey, Grosse Ile,
MI (US)

AU 655 926 B 1/1996
CA 2 403 319 3/2003

(Continued)

(73) Assignee: **ASC Incorporated**, Southgate, MI (US)
(**) Term: **14 Years**

OTHER PUBLICATIONS

Photographs of 1942 Rolls-Royce, "Duchess" Fleetwood
seda with stationary roof (believed to have been offered for
sale or publicly used in 1942).

(21) Appl. No.: **29/236,263**

(Continued)

(22) Filed: **Aug. 12, 2005**

Primary Examiner—Melody N. Brown

(51) **LOC (8) Cl.** **12-08**

(52) **U.S. Cl.** **D12/92**

(58) **Field of Classification Search** D12/90-92,
D12/86, 88; D21/424, 433; 296/181.1, 181.5
See application file for complete search history.

(74) *Attorney, Agent, or Firm*—Harness, Dickey & Pierce,
P.L.C.

(57) **CLAIM**

The ornamental design for an automobile vehicle and/or toy
replica thereof, as shown and described.

(56) **References Cited**

DESCRIPTION

U.S. PATENT DOCUMENTS

1,694,546 A	12/1928	Lancia
1,794,465 A	3/1931	Ledwinka
1,797,989 A	3/1931	Ledwinka
2,370,211 A	2/1945	Ulrich
2,597,837 A	5/1952	Lindsay
2,751,247 A	6/1956	Barenyi
3,021,172 A	2/1962	Fiala et al.
3,154,341 A	10/1964	Booth
3,172,695 A	3/1965	Bordinat, Jr.
3,328,935 A	7/1967	Peras
3,944,276 A	3/1976	de Rosa et al.
4,230,361 A	10/1980	Nachbur et al.
4,231,607 A	11/1980	Bohlin
4,346,930 A	8/1982	Northey
4,493,506 A	1/1985	Alexander
4,514,891 A	5/1985	Draper
4,570,321 A	2/1986	Draper
4,613,184 A	9/1986	Rispeter et al.
4,634,171 A	1/1987	McKeag
4,660,345 A	4/1987	Browning

FIG. 1 is a top perspective view showing an automotive
vehicle and/or toy replica thereof, of the new design;
FIG. 2 is a side and rear perspective view showing the
automotive vehicle and/or toy replica thereof, of the new
design;
FIG. 3 is a side and front perspective view showing the
automotive vehicle and/or toy replica thereof, of the new
design;
FIG. 4 is a side perspective view showing the automotive
vehicle and/or toy replica thereof, of the new design, the
opposite side being a mirrored image of FIG. 4;
FIG. 5 is a rear perspective view showing the automotive
vehicle and/or toy replica thereof, of the new design; and,
FIG. 6 is a front perspective view showing the automotive
vehicle and/or toy replica thereof, of the new design.
The broken and shading lines within the drawings are for
illustrative purposes only and form no part of the presently
claimed invention.

(Continued)

1 Claim, 6 Drawing Sheets

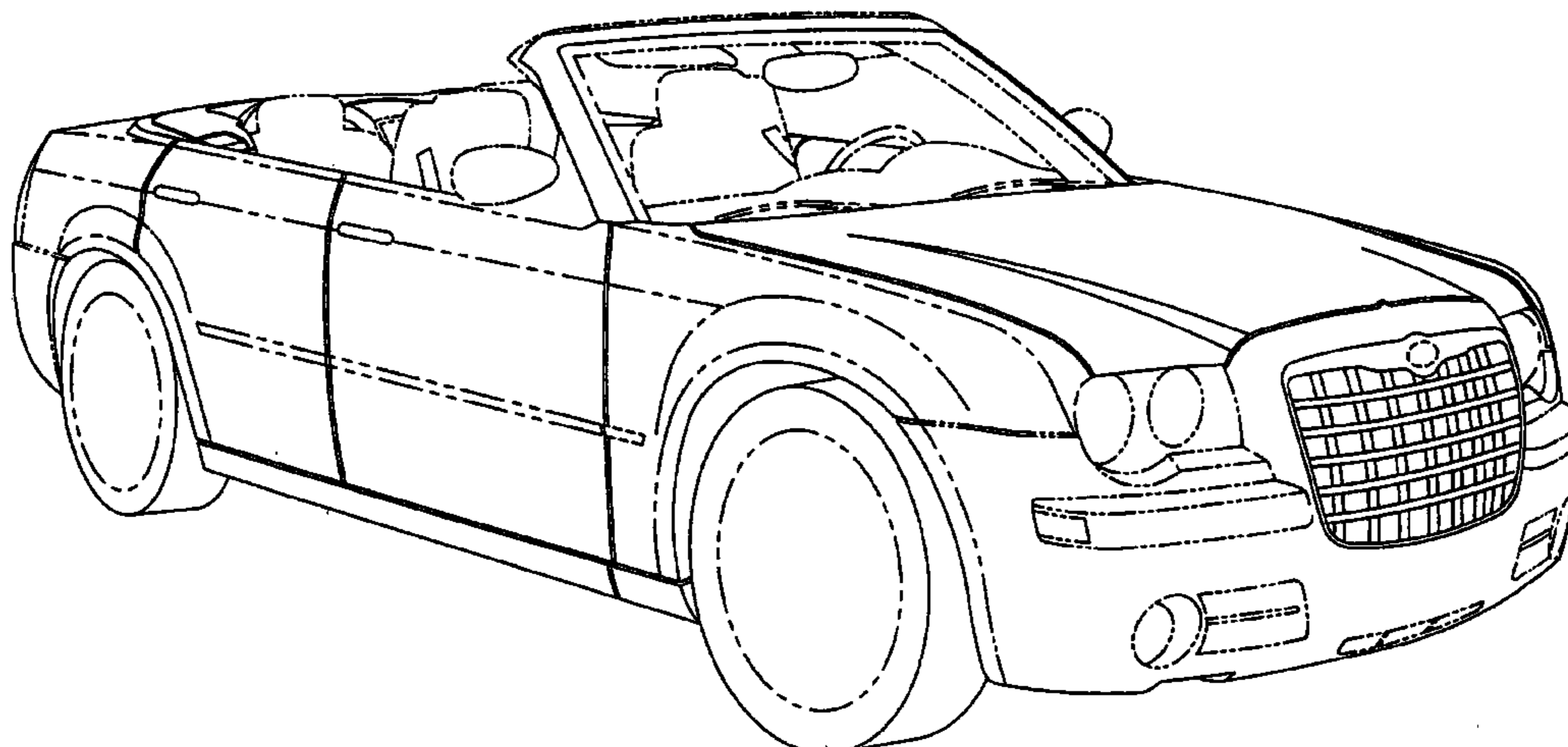

U.S. PATENT DOCUMENTS

4,662,052 A 5/1987 Draper
 4,729,156 A 3/1988 Norris, Jr. et al.
 4,892,350 A 1/1990 Kijima
 4,934,751 A 6/1990 Shimoda
 4,940,282 A 7/1990 Townsend
 4,944,553 A 7/1990 Medley et al.
 4,950,026 A 8/1990 Emmons
 4,958,862 A 9/1990 Cappelli et al.
 4,958,882 A 9/1990 Kolb
 4,968,087 A 11/1990 Gorla
 5,018,780 A 5/1991 Yoshii et al.
 5,020,846 A 6/1991 Bonnett
 5,094,478 A 3/1992 Pfanzeder et al.
 5,110,176 A 5/1992 Curtis
 5,351,400 A 10/1994 Samuel
 5,388,885 A 2/1995 Warren
 5,435,618 A 7/1995 Sacco et al.
 5,575,531 A 11/1996 Gauger et al.
 5,577,796 A 11/1996 Clausen
 5,577,797 A 11/1996 Takanishi
 5,584,525 A 12/1996 Nakano et al.
 5,613,727 A 3/1997 Yamazaki
 5,641,193 A 6/1997 Zepnik et al.
 5,641,194 A 6/1997 Honma et al.
 D391,547 S 3/1998 Lehmann et al.
 5,772,274 A 6/1998 Tokarz
 5,788,322 A 8/1998 Wolf et al.
 5,803,533 A 9/1998 Schulz et al.
 5,806,918 A 9/1998 Kanazawa
 5,868,426 A 2/1999 Edwards et al.
 D406,792 S 3/1999 Alexander et al.
 5,881,458 A 3/1999 Wolf et al.
 5,921,618 A 7/1999 Mori et al.
 5,954,390 A 9/1999 Kleinhoffer et al.
 5,988,734 A 11/1999 Longo et al.
 5,992,921 A 11/1999 Seki
 5,997,078 A 12/1999 Beck et al.
 6,007,145 A 12/1999 Tezuka
 6,039,386 A 3/2000 Hasshi et al.
 6,053,567 A 4/2000 Ito
 D427,138 S 6/2000 Alexander et al.
 6,126,232 A 10/2000 Nakano
 6,139,082 A 10/2000 Davis, Jr. et al.
 6,168,228 B1 1/2001 Heinz et al.
 6,176,544 B1 1/2001 Seksaria et al.
 6,189,952 B1 2/2001 Schmidt et al.
 6,220,654 B1 4/2001 Sommer
 D442,541 S 5/2001 Alexander et al.
 6,237,991 B1 5/2001 Weber
 6,270,153 B1 8/2001 Toyao et al.
 6,273,498 B1 8/2001 Hillman et al.
 6,296,301 B1 10/2001 Schroeder et al.
 6,299,238 B1 10/2001 Takagi et al.
 6,299,239 B1 10/2001 Sagawa et al.
 6,299,240 B1 10/2001 Schroeder et al.
 6,315,353 B1 11/2001 Brodt et al.
 6,332,643 B1 12/2001 Sukegawa et al.
 D452,675 S 1/2002 Alexander et al.
 6,382,710 B1 5/2002 Funk et al.
 6,398,292 B2 6/2002 Tsuruta et al.
 6,434,907 B1 8/2002 Simboli
 6,443,517 B1 9/2002 Just et al.
 6,443,518 B1 9/2002 Rohl et al.

D464,605 S 10/2002 Alexander et al.
 6,491,337 B2 12/2002 Averdick et al.
 6,540,286 B2 4/2003 Takemoto et al.
 6,568,745 B2 5/2003 Kosuge et al.
 6,572,181 B2 6/2003 Jonsson
 6,578,903 B2 6/2003 Ernst et al.
 6,604,781 B2 8/2003 Uchida
 6,644,725 B2 11/2003 Braitmaier et al.
 6,655,729 B2 12/2003 Neale
 6,666,500 B2 12/2003 Polzer et al.
 6,679,546 B2 1/2004 Mishima et al.
 6,688,677 B2 2/2004 Glashagel et al.
 D490,024 S * 5/2004 Zavatski et al. D12/92
 D494,101 S * 8/2004 Zavatski et al. D12/92
 D500,000 S * 12/2004 Dyson et al. D12/92
 6,869,132 B2 3/2005 Wang et al.
 2001/0019216 A1 9/2001 Kobayashi
 2001/0045759 A1 11/2001 Russke
 2002/0057004 A1 5/2002 Corcoran et al.
 2002/0089225 A1 7/2002 Bruck et al.
 2002/0145307 A1 10/2002 Fujita
 2002/0153749 A1 10/2002 Lee
 2002/0163225 A1 11/2002 Glashagel et al.
 2002/0195840 A1 12/2002 Mishima et al.
 2003/0006629 A1 1/2003 Kimura et al.
 2003/0034671 A1 2/2003 Streiff et al.
 2003/0038498 A1 2/2003 Rajasingham
 2003/0062742 A1 4/2003 Neale
 2003/0209929 A1 11/2003 Muin et al.
 2005/0057077 A1 3/2005 Telehowski et al.

FOREIGN PATENT DOCUMENTS

DE 4211918 3/1993
 DE 196 03 098 A1 7/1997
 DE 199 16 849 10/2000
 EP 0 059 147 5/1985
 EP 1 151 882 11/2001
 FR 2 120 326 A 8/1972
 GB 273894 7/1927
 JP 6-99851 4/1994
 JP 11-115662 4/1999
 WO WO 02/096675 12/2002

OTHER PUBLICATIONS

Photographs of 1931 Series 355 7-passenger touring vehicle with convertible roof and four doors (believed to have been offered for sale or publicly used in 1931).
 Photos and description of Kennedy Presidential Limousine (publicly used in 1960s).
 G. Guzzardi and E. Rizzo, Convertibles—History and Evolution of Dream Cars (1998), 38 pages.
 Photographs of Rolls Royce (publicly used or published in 1956).
 Photographs of Lincoln Continental Limousine (publicly used or published prior to 2003).
 “Drop-top Rolls”, Nov. 22, 2004, AutoWeek, p. 4.
 Mark Vaughn, “Chrysler 300C Cabriolet”, (Newport Convertible Engineering, Inc.), Nov. 22, 2004, AutoWeek, p. 4.
 3 Photographs of Chrysler 300 Vehicles (offered for sale before Jul. 2005).

* cited by examiner

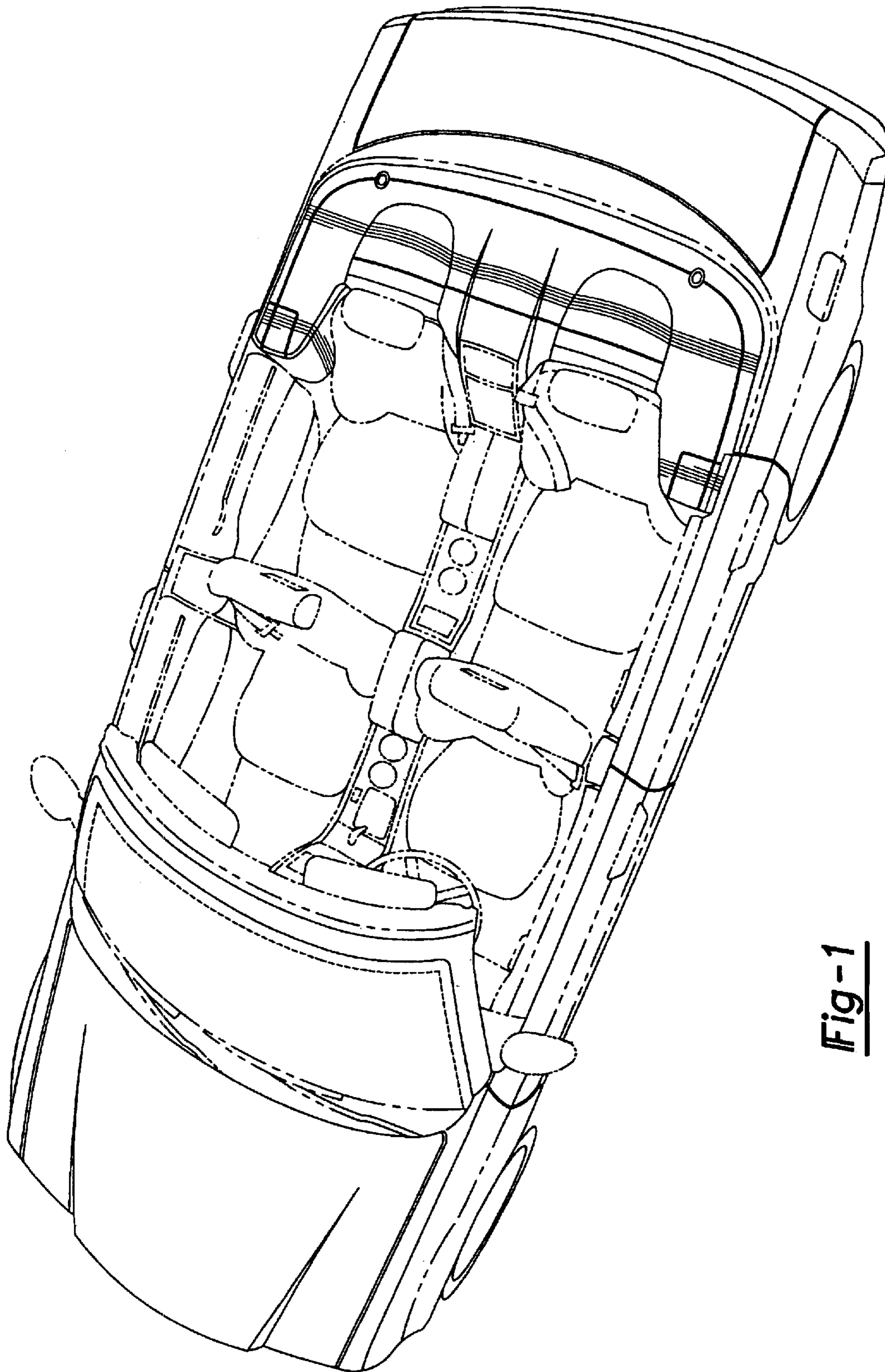

Fig-1

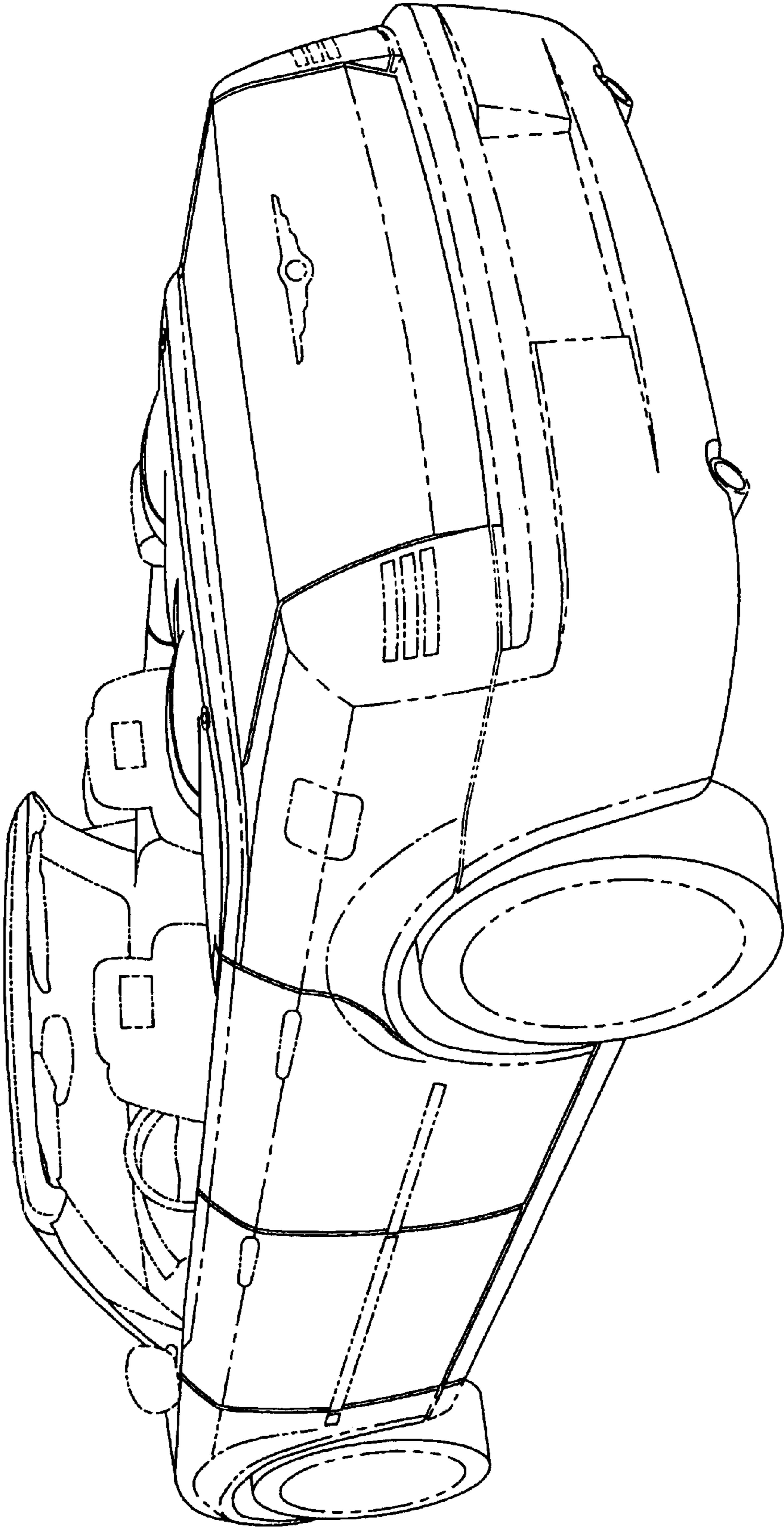

Fig-2

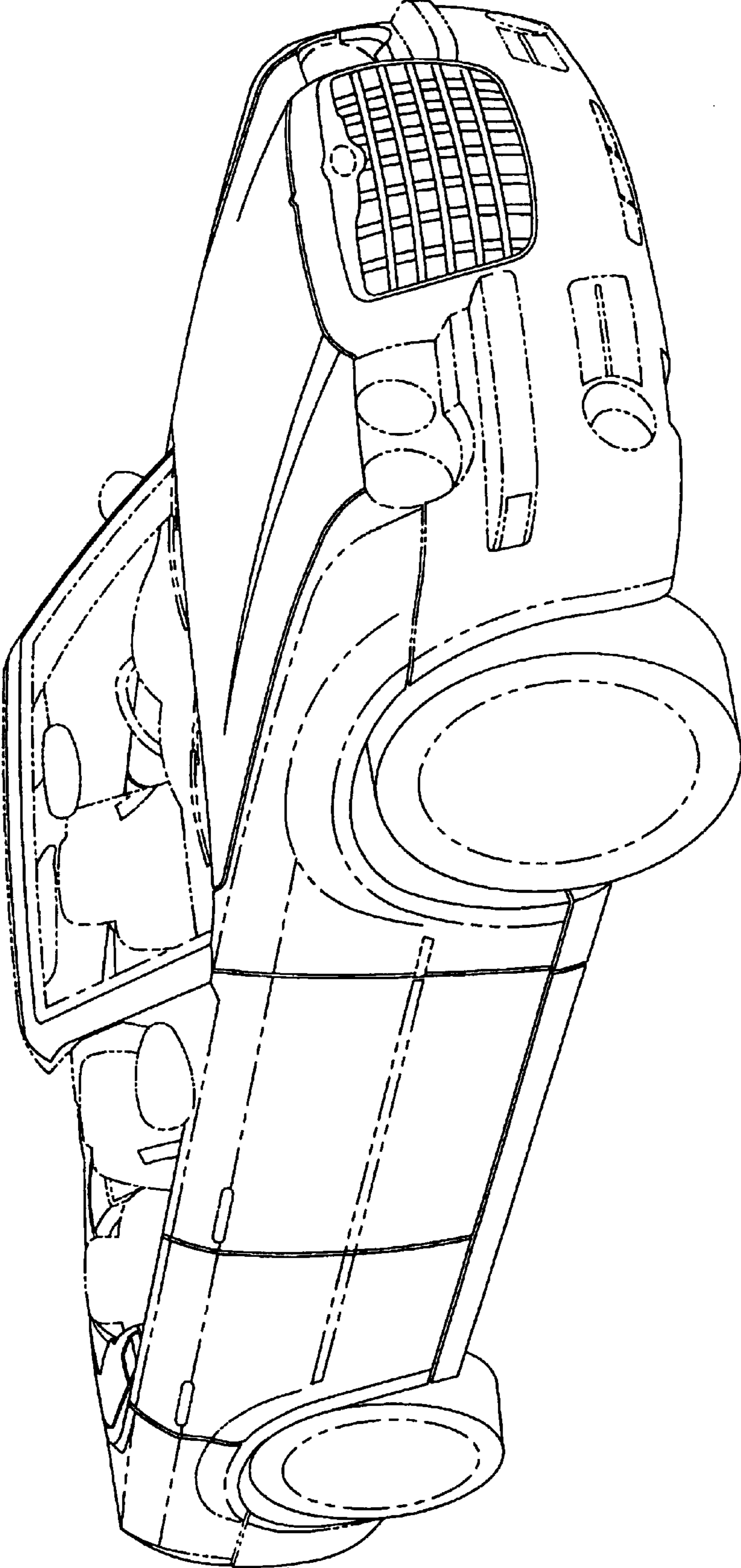

Fig-3

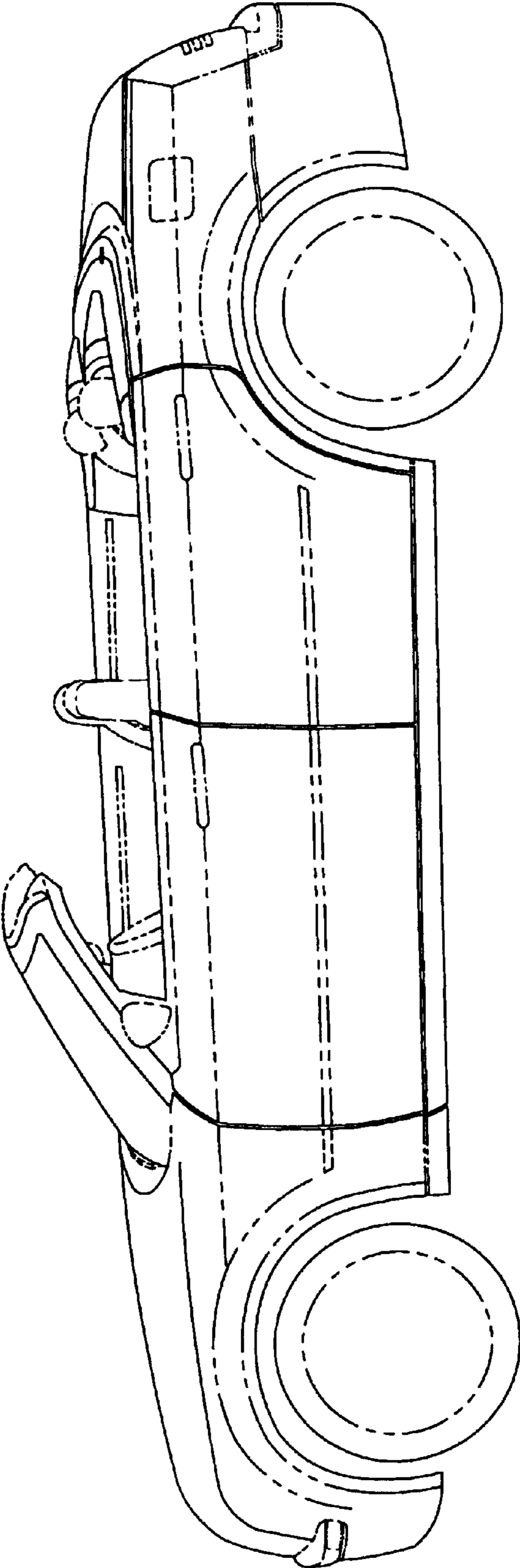

Fig-4

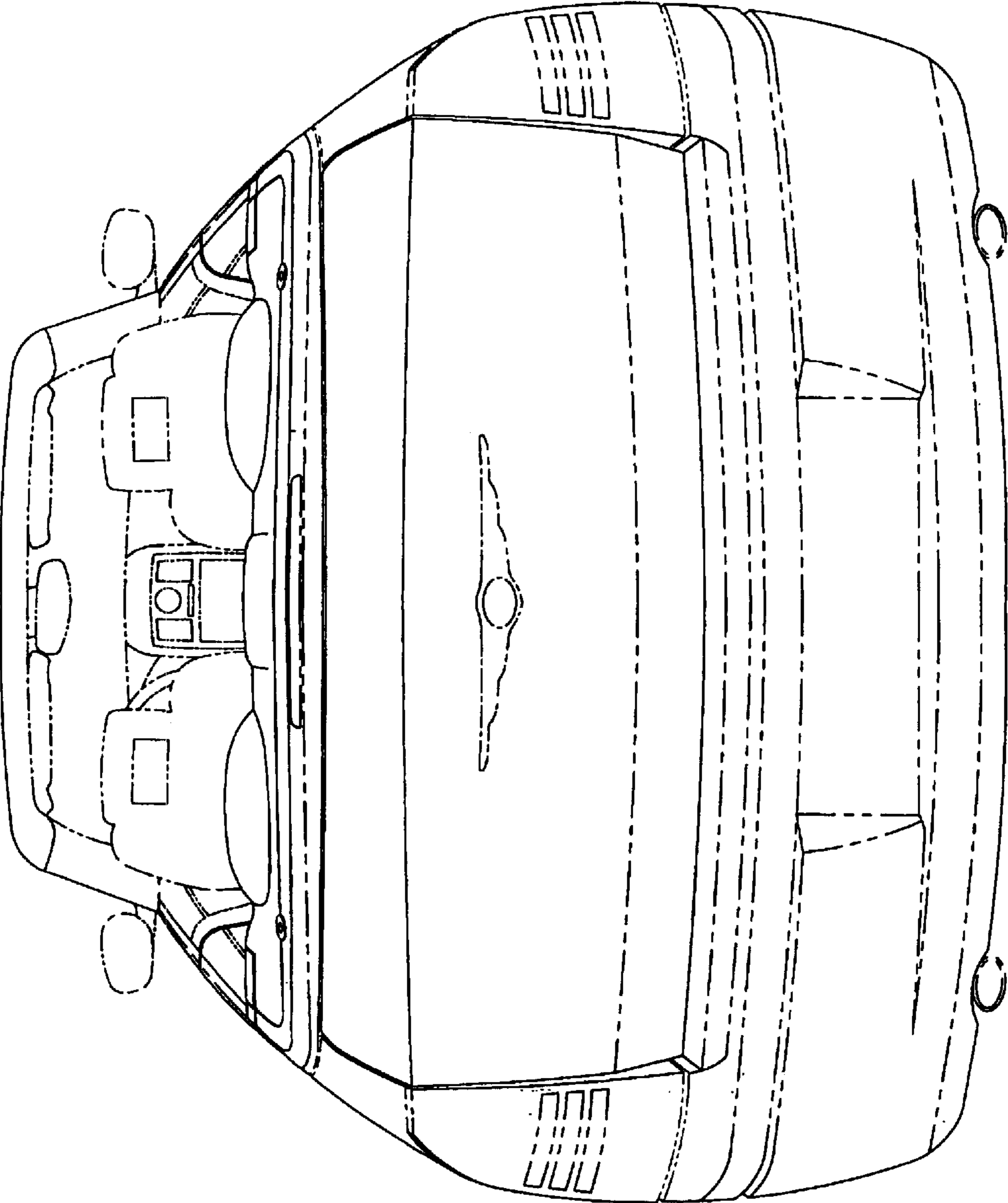

Fig-5

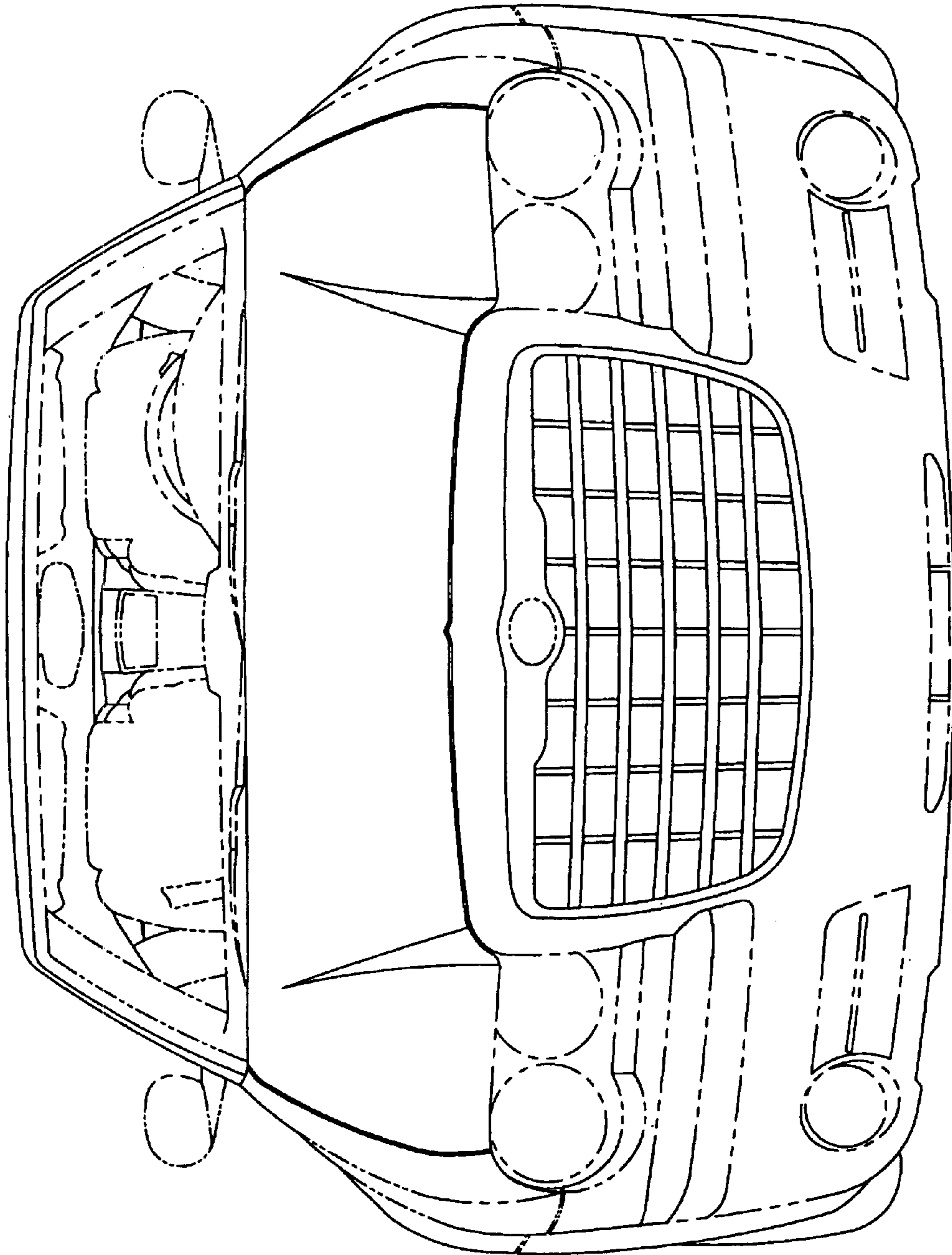

Fig-6

UNITED STATES PATENT AND TRADEMARK OFFICE
CERTIFICATE OF CORRECTION

PATENT NO. : Des. 543,135 S
APPLICATION NO. : 29/236263
DATED : May 22, 2007
INVENTOR(S) : D. Mark Trostle and Christopher C. Dowdey

Page 1 of 1

It is certified that error appears in the above-identified patent and that said Letters Patent is hereby corrected as shown below:

TITLE PAGE, No. (57), Claim, line 1, "automobile" should be --automotive--.

Signed and Sealed this

Fourth Day of December, 2007

A handwritten signature in black ink on a dotted background. The signature reads "Jon W. Dudas" in a cursive style.

JON W. DUDAS

Director of the United States Patent and Trademark Office