



US00D542817S

(12) **United States Design Patent** (10) **Patent No.:** **US D542,817 S**  
**George** (45) **Date of Patent:** **\*\* May 15, 2007**

- (54) **DIGITAL VIBRATION METER**
- (75) Inventor: **James George**, Wilmette, IL (US)
- (73) Assignee: **ENM Company**, Chicago, IL (US)
- (\*\*) Term: **14 Years**
- (21) Appl. No.: **29/266,375**
- (22) Filed: **Sep. 20, 2006**

**Related U.S. Application Data**

- (63) Continuation of application No. 29/227,827, filed on Apr. 15, 2005, now abandoned.
- (51) **LOC (8) Cl.** ..... **15-09**
- (52) **U.S. Cl.** ..... **D15/147**
- (58) **Field of Classification Search** ..... D10/46, D10/104, 106, 110, 111; D15/147; 73/570, 73/652, 653, 655-657, 662; 250/231.1, 231.11, 250/231.12, 231.13, 231.14, 231.15, 231.16, 250/231.18, 231.19, 239  
See application file for complete search history.

**References Cited**

**U.S. PATENT DOCUMENTS**

D249,248 S	*	9/1978	Gibbs	.....	D10/106
D280,390 S	*	9/1985	Schweitzer	.....	D10/106
D281,401 S	*	11/1985	Perrins	.....	D10/106
D332,923 S		2/1993	Polydoris et al.		
D348,019 S		6/1994	Kocol et al.		
D348,408 S		7/1994	Mazulis		
D365,035 S	*	12/1995	Haber et al.	.....	D10/106
D369,753 S	*	5/1996	Baril	.....	D10/104
D371,752 S	*	7/1996	Stemporzewski, Jr.	.....	D10/104
6,789,030 B1	*	9/2004	Coyle et al.	.....	702/77

\* cited by examiner

*Primary Examiner*—Antoine D. Davis  
*Assistant Examiner*—Patricia Palasik  
(74) *Attorney, Agent, or Firm*—McDermott Will & Emery

(57) **CLAIM**

What is claimed is the ornamental design for a digital vibration meter, as shown and described.

**DESCRIPTION**

FIG. 1 is a perspective view of a digital vibration meter according to the new design;  
 FIG. 2 is a front view of the digital vibration meter shown in FIG. 1, the rear view being identical thereto;  
 FIG. 3 is a top view of the digital vibration meter shown in FIG. 1;  
 FIG. 4 is a side elevation view of one side of the digital vibration meter shown in FIG. 1, the other side view being identical thereto;  
 FIG. 5 is a bottom view of the digital vibration meter shown in FIG. 1;  
 FIG. 6 is a perspective view of another embodiment of a digital vibration meter according to the new design;  
 FIG. 7 is a front view of the digital vibration meter shown in FIG. 6, the rear view being identical thereto;  
 FIG. 8 is a top view of the digital vibration meter shown in FIG. 6;  
 FIG. 9 is a side elevation view of one side of the digital vibration meter shown in FIG. 6, the other side view being identical thereto; and,  
 FIG. 10 is a bottom view of the digital vibration meter shown in FIG. 6.  
 Features shown in broken lines form no part of the claimed design.

**1 Claim, 2 Drawing Sheets**

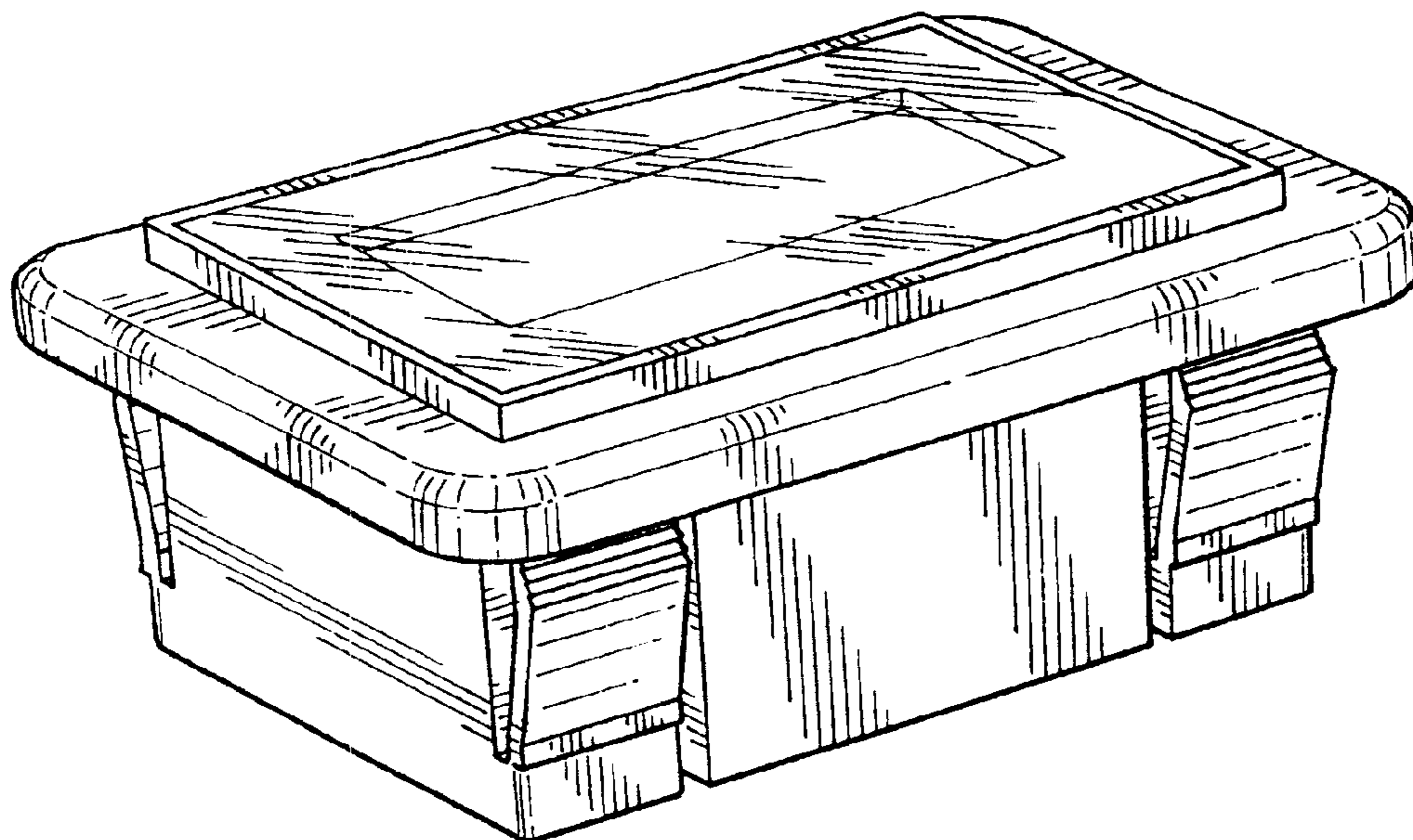

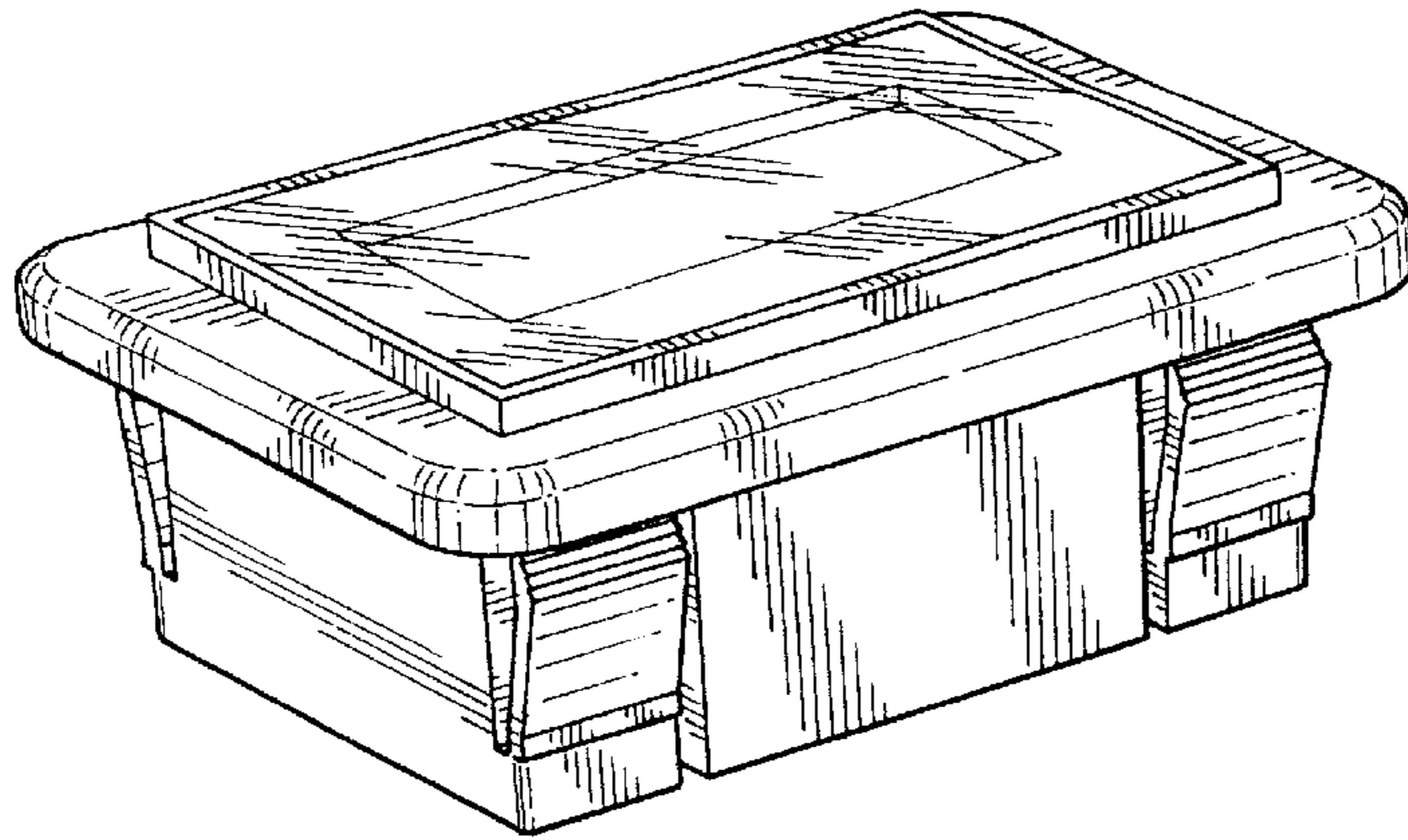

FIG. 1

FIG. 2

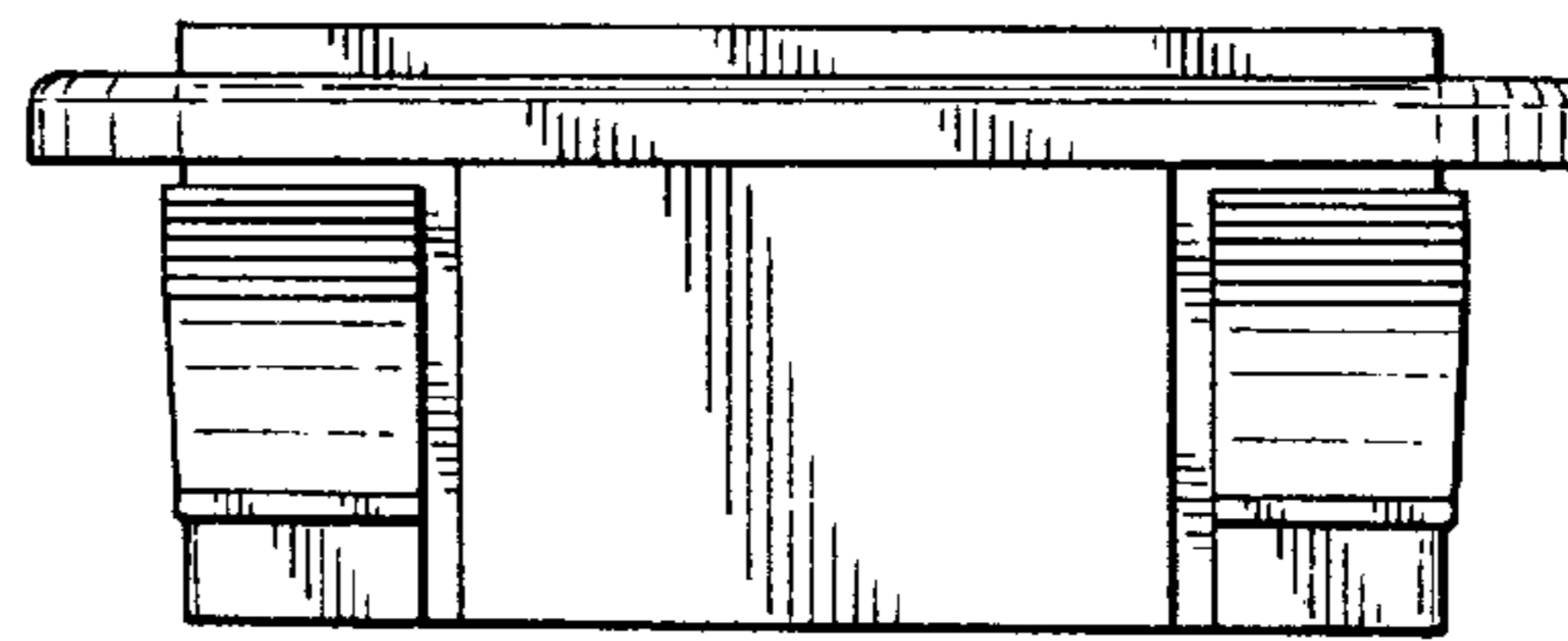

FIG. 3

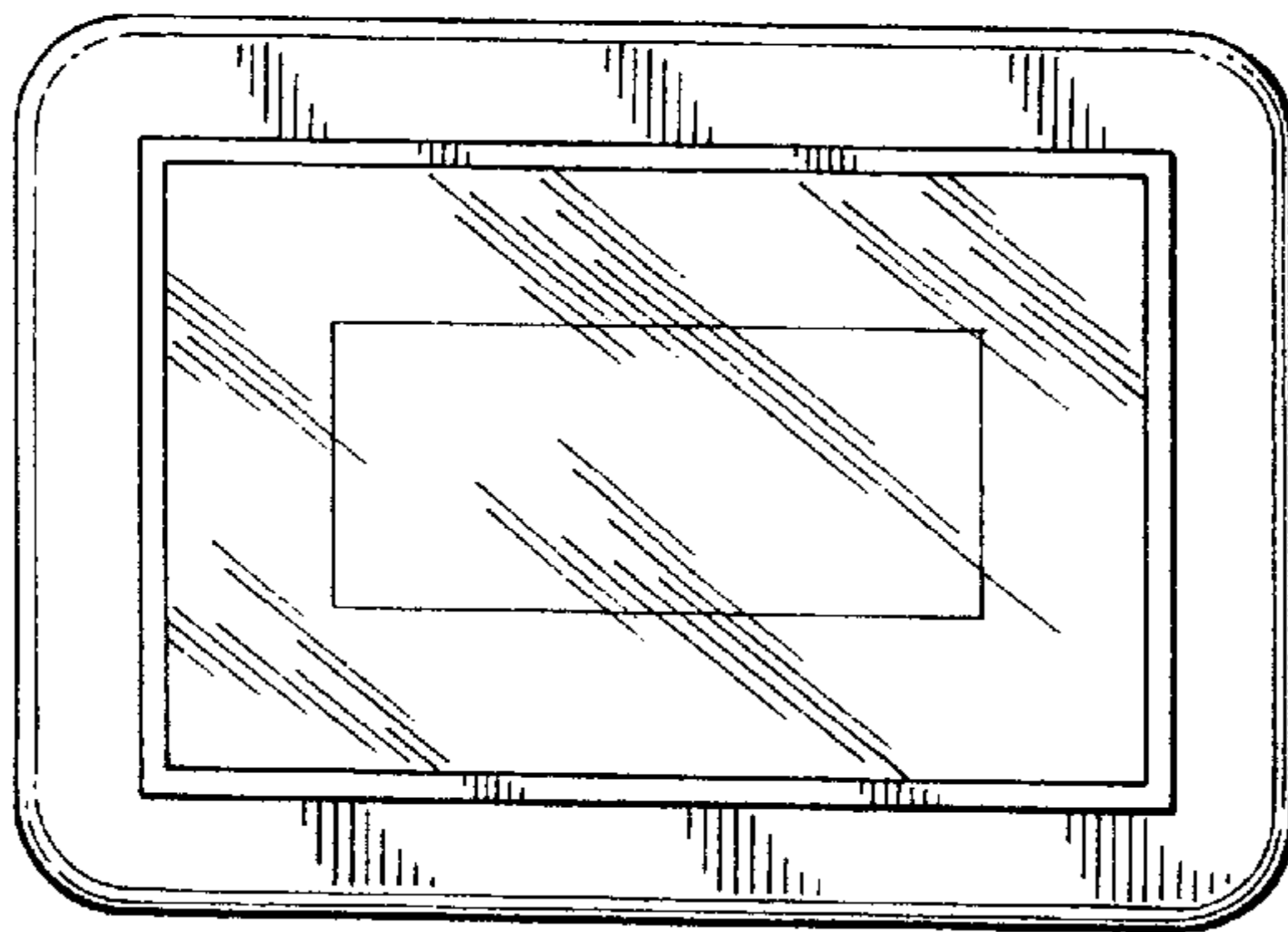

FIG. 4

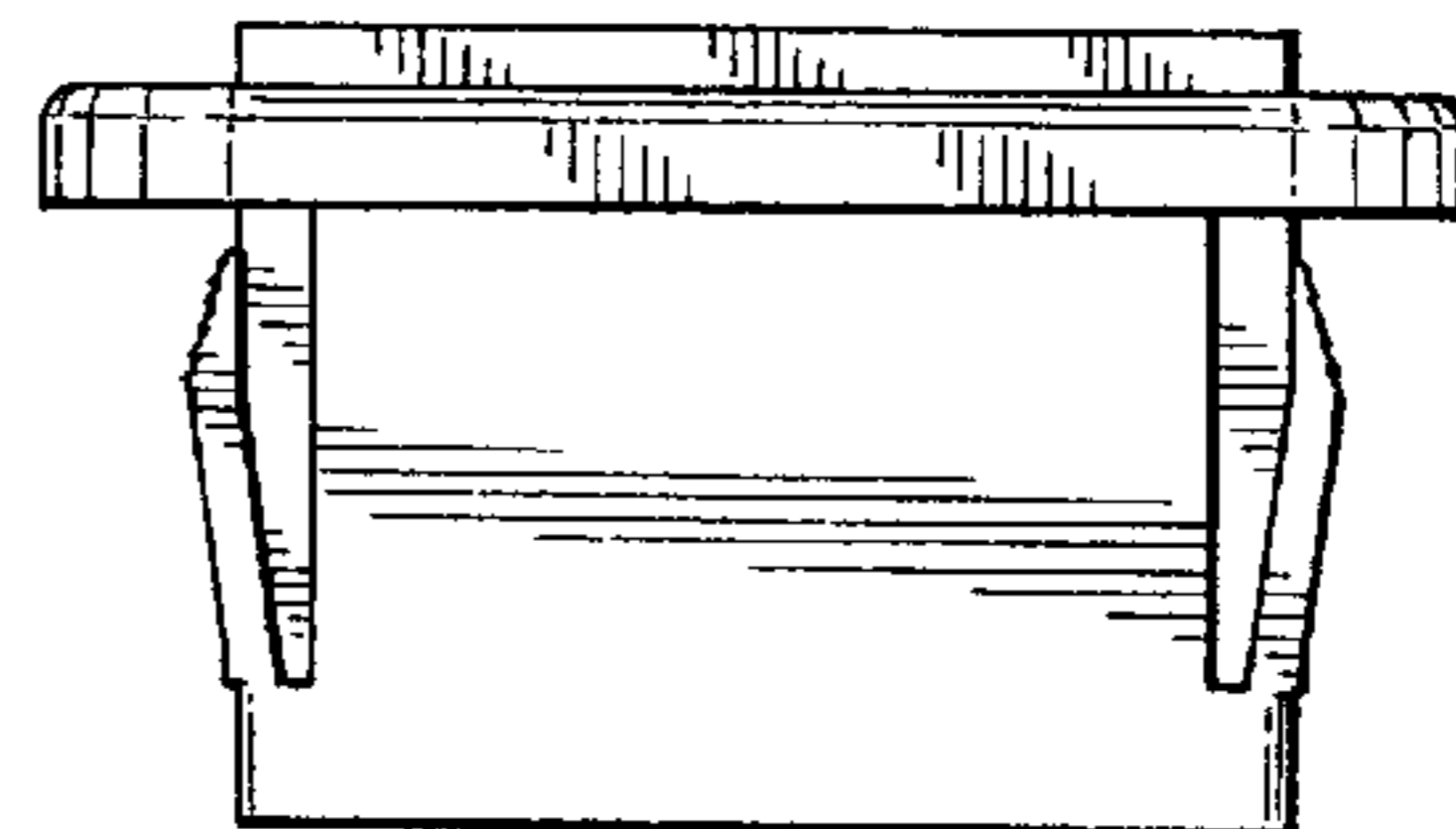
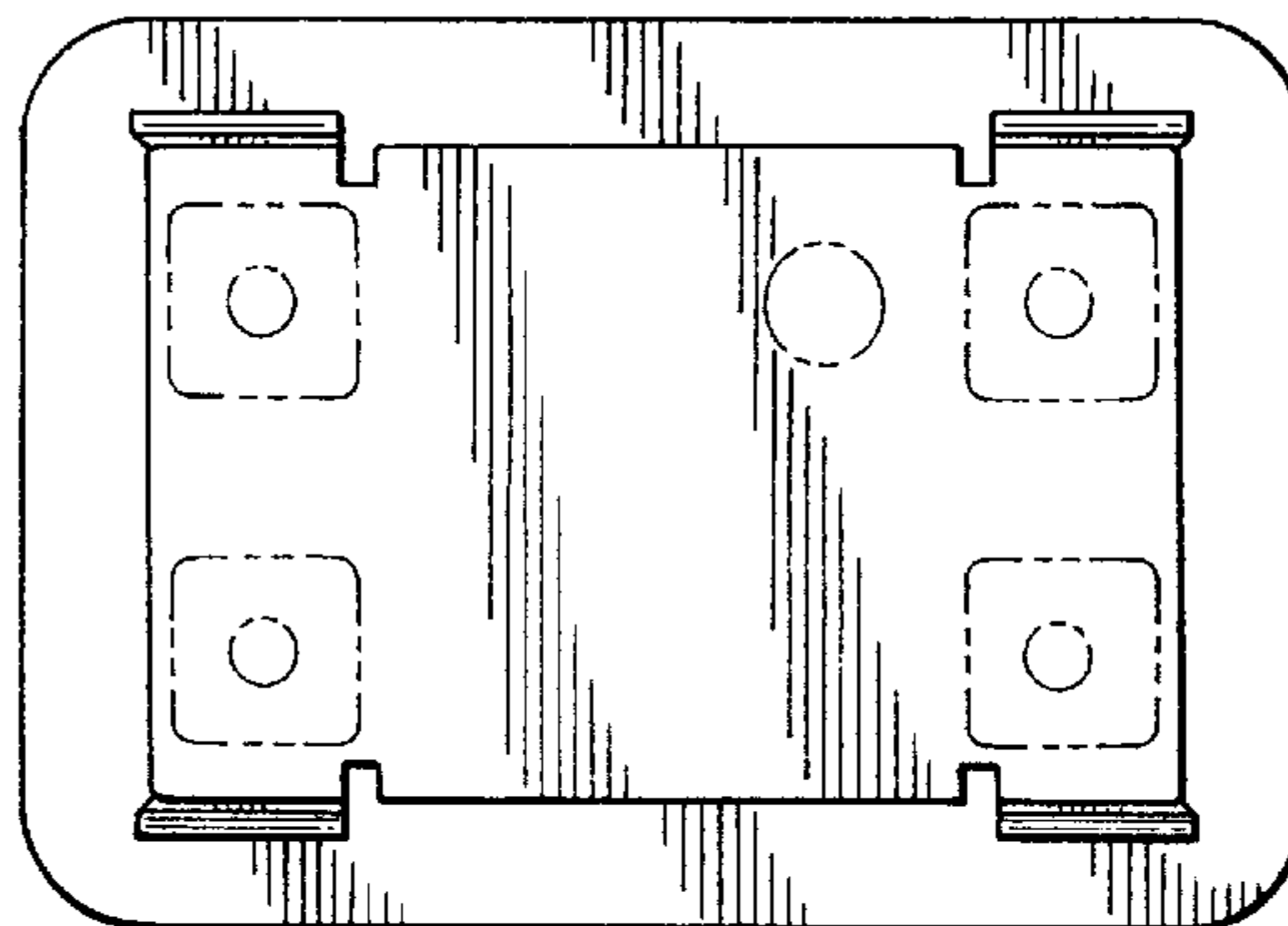

FIG. 5



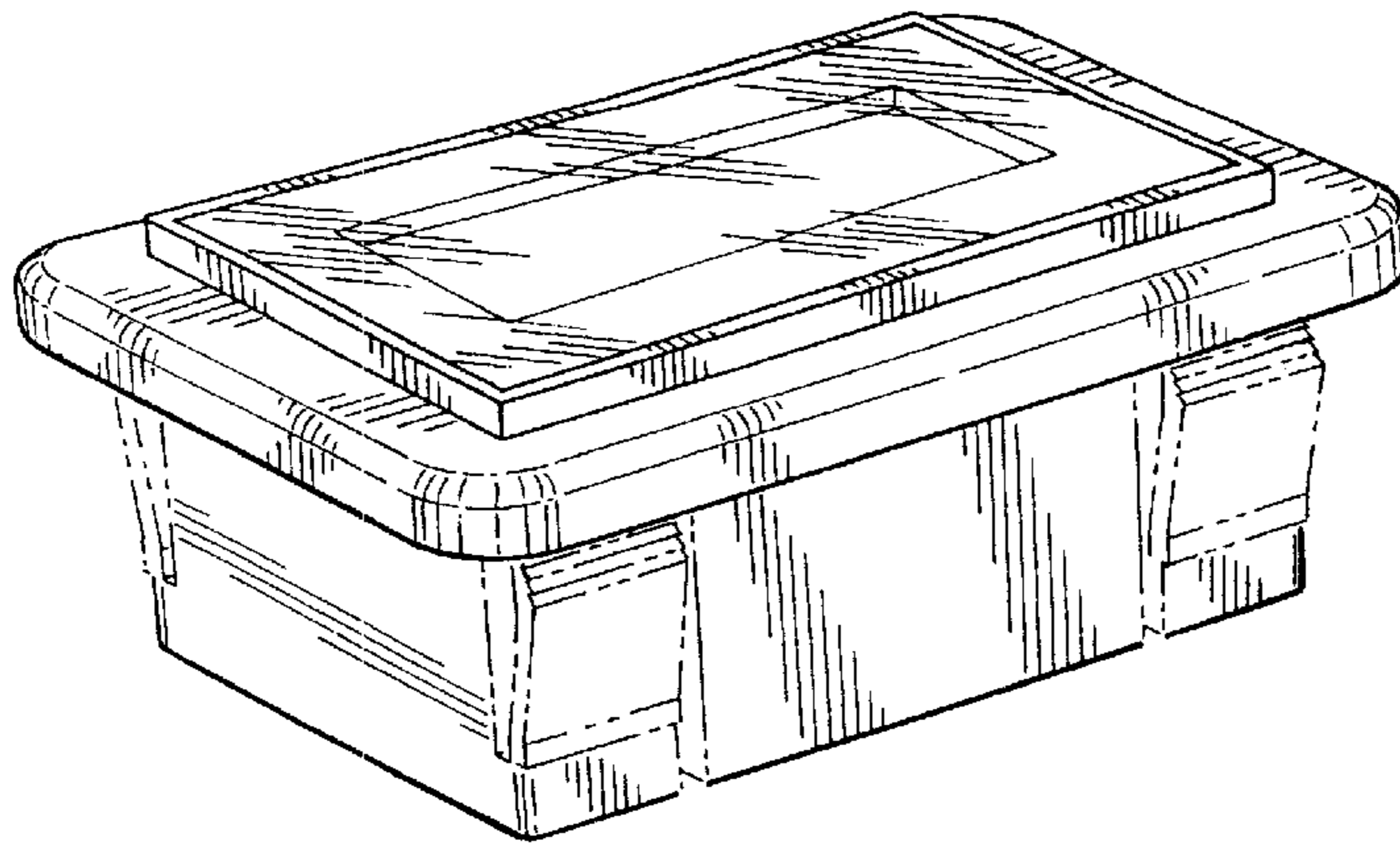

FIG. 6

FIG. 7

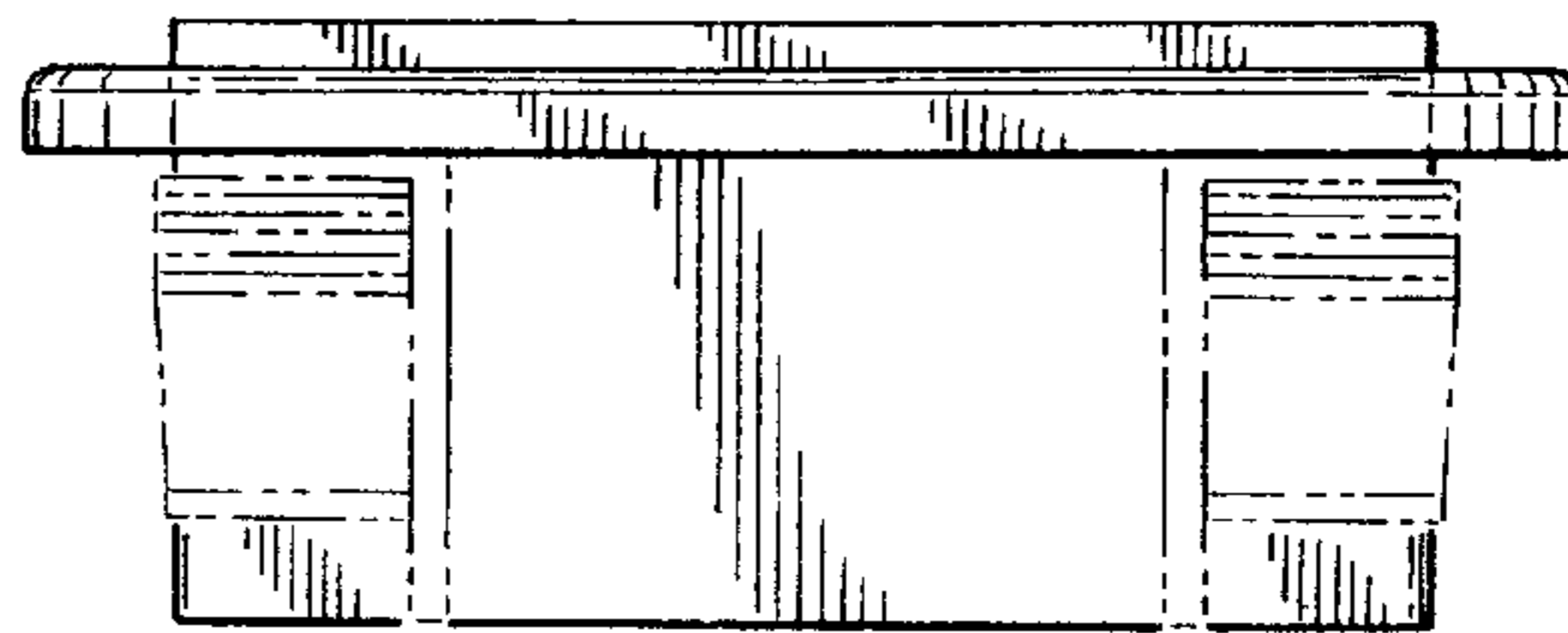

FIG. 8

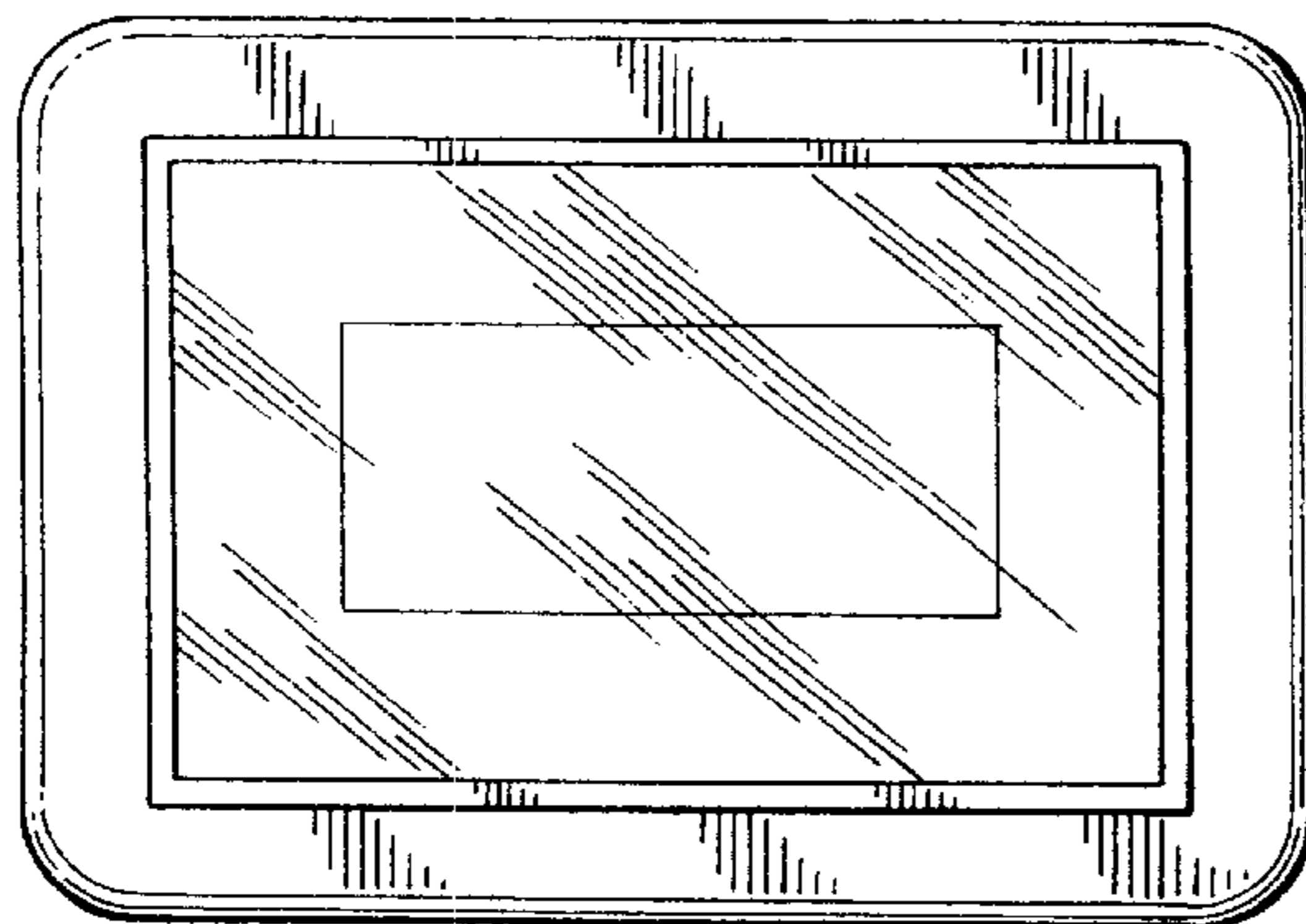

FIG. 9

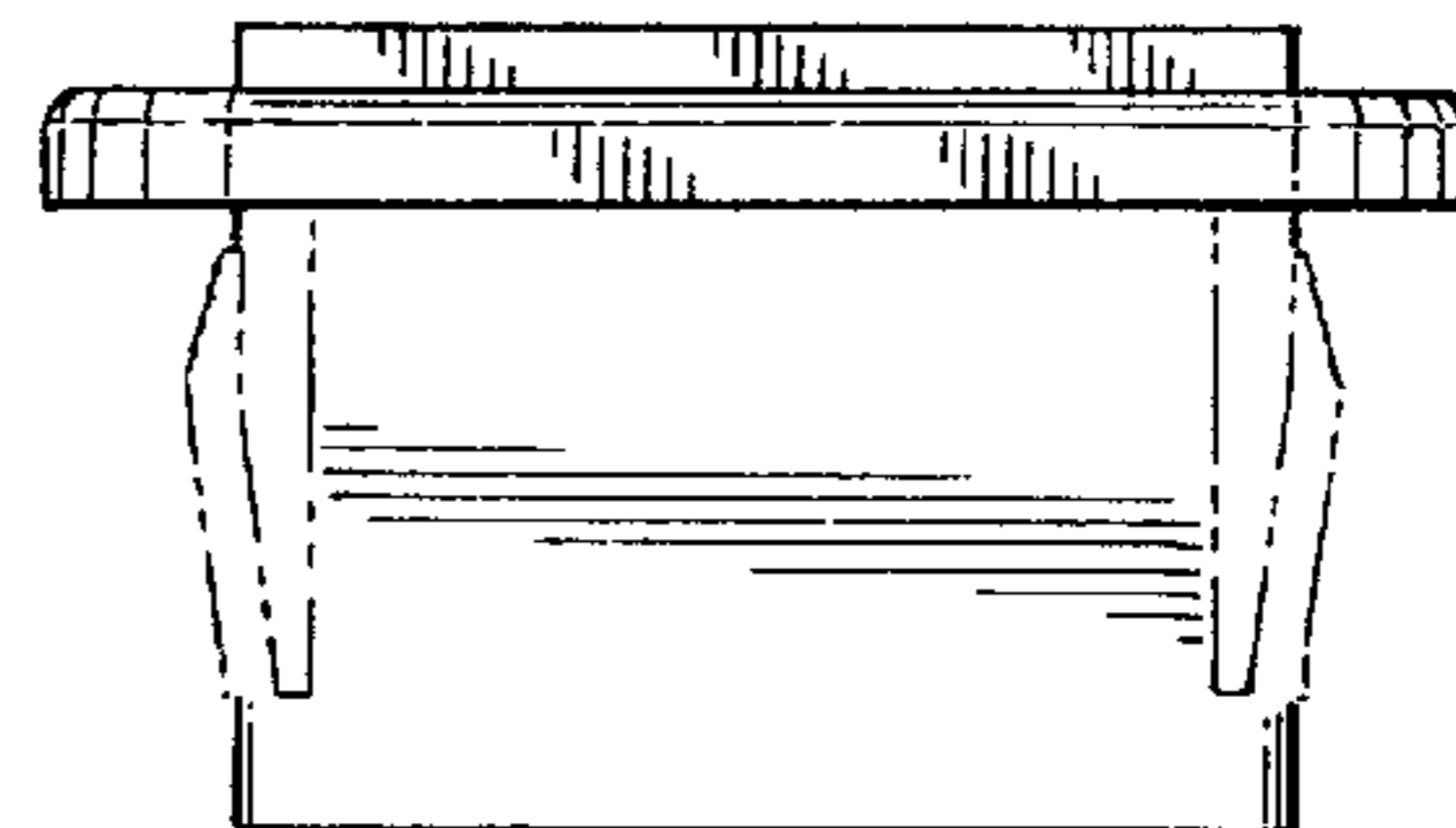

FIG. 10

