



US00D542726S

(12) **United States Design Patent**  
**Hieke**

(10) **Patent No.:** **US D542,726 S**

(45) **Date of Patent:** **\*\* May 15, 2007**

(54) **FRONT FACE OF VEHICLE WHEEL**

(75) Inventor: **Claus Hieke**, Sindelfingen (DE)

(73) Assignee: **DaimlerChrysler AG**, Stuttgart (DE)

(\*\*) Term: **14 Years**

(21) Appl. No.: **29/268,810**

(22) Filed: **Nov. 14, 2006**

(30) **Foreign Application Priority Data**

May 15, 2006 (EM) ..... 000529185-0004  
May 15, 2006 (EM) ..... 000529185-0003

(51) **LOC (8) Cl.** ..... **12-16**

(52) **U.S. Cl.** ..... **D12/209**

(58) **Field of Classification Search** ..... D12/204-213;  
301/37.101, 64.101, 65

See application file for complete search history.

(56) **References Cited**

**U.S. PATENT DOCUMENTS**

D420,637 S \* 2/2000 Glade ..... D12/209  
D437,821 S \* 2/2001 Fröhlich ..... D12/211  
D452,839 S \* 1/2002 Muth et al. .... D12/209  
D454,105 S \* 3/2002 Pfeiffer ..... D12/209

D480,676 S \* 10/2003 Bhambra ..... D12/211  
D494,524 S \* 8/2004 Rice ..... D12/211  
D502,135 S \* 2/2005 Weld ..... D12/211  
D515,491 S \* 2/2006 Elmitt ..... D12/209  
D530,258 S \* 10/2006 Schell ..... D12/211  
D531,104 S \* 10/2006 Kim ..... D12/209

\* cited by examiner

*Primary Examiner*—Stacia Cadmus

(74) *Attorney, Agent, or Firm*—Crowell & Moring LLP

(57) **CLAIM**

The ornamental design for a front face of a vehicle wheel, as shown and described.

**DESCRIPTION**

FIG. 1 is a front view of a first embodiment of a front face of a vehicle wheel according to my novel design; and FIG. 2 is a perspective view thereof.

FIG. 3 is a front view of a second embodiment of the front face of a vehicle wheel according to my novel design; and, FIG. 4 is a perspective view thereof.

The broken lines are for illustrative purposes only and form no part of the claimed design. Also enclosed is a set of photographs of an embodiment of the design.

**1 Claim, 2 Drawing Sheets**

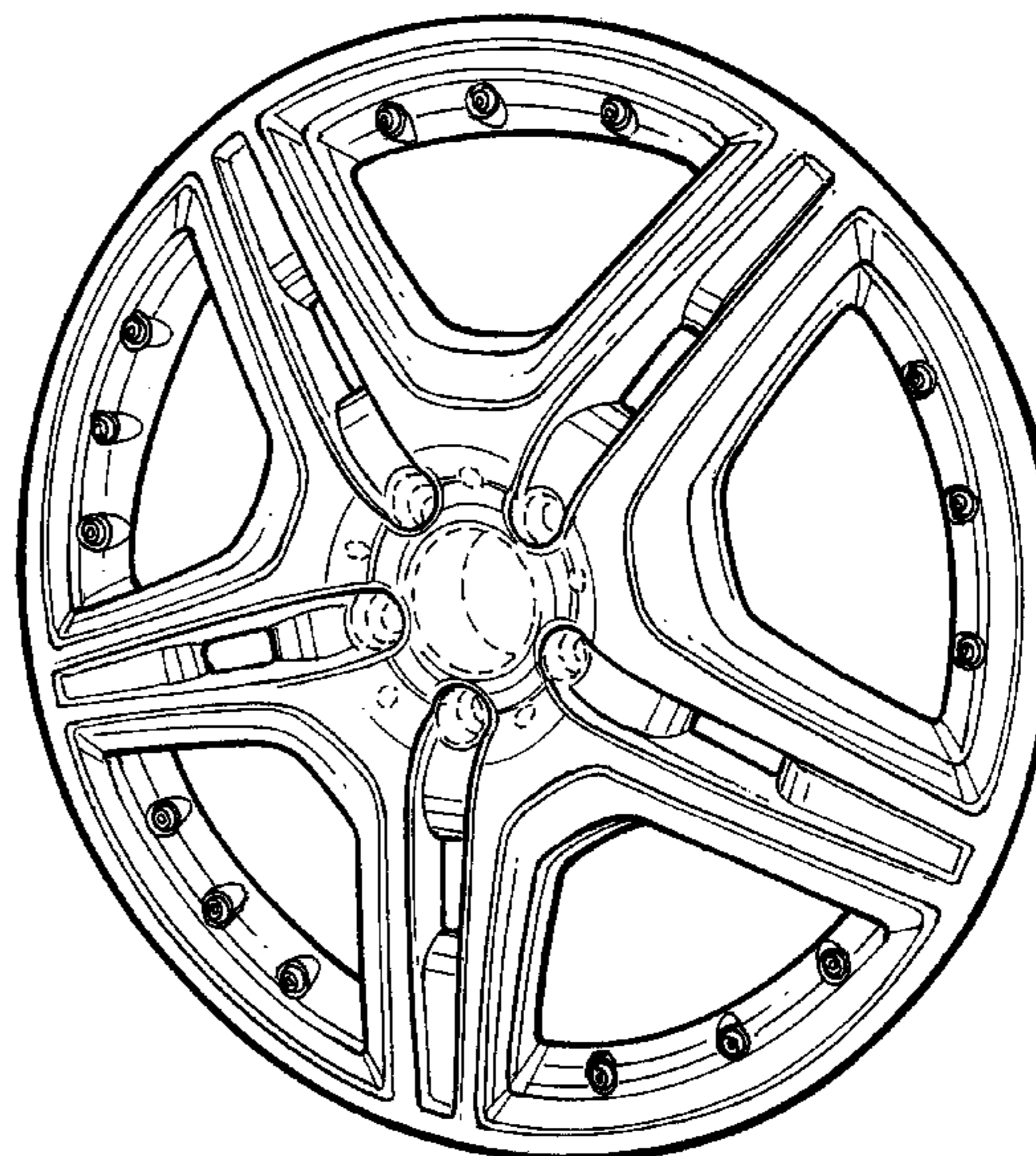
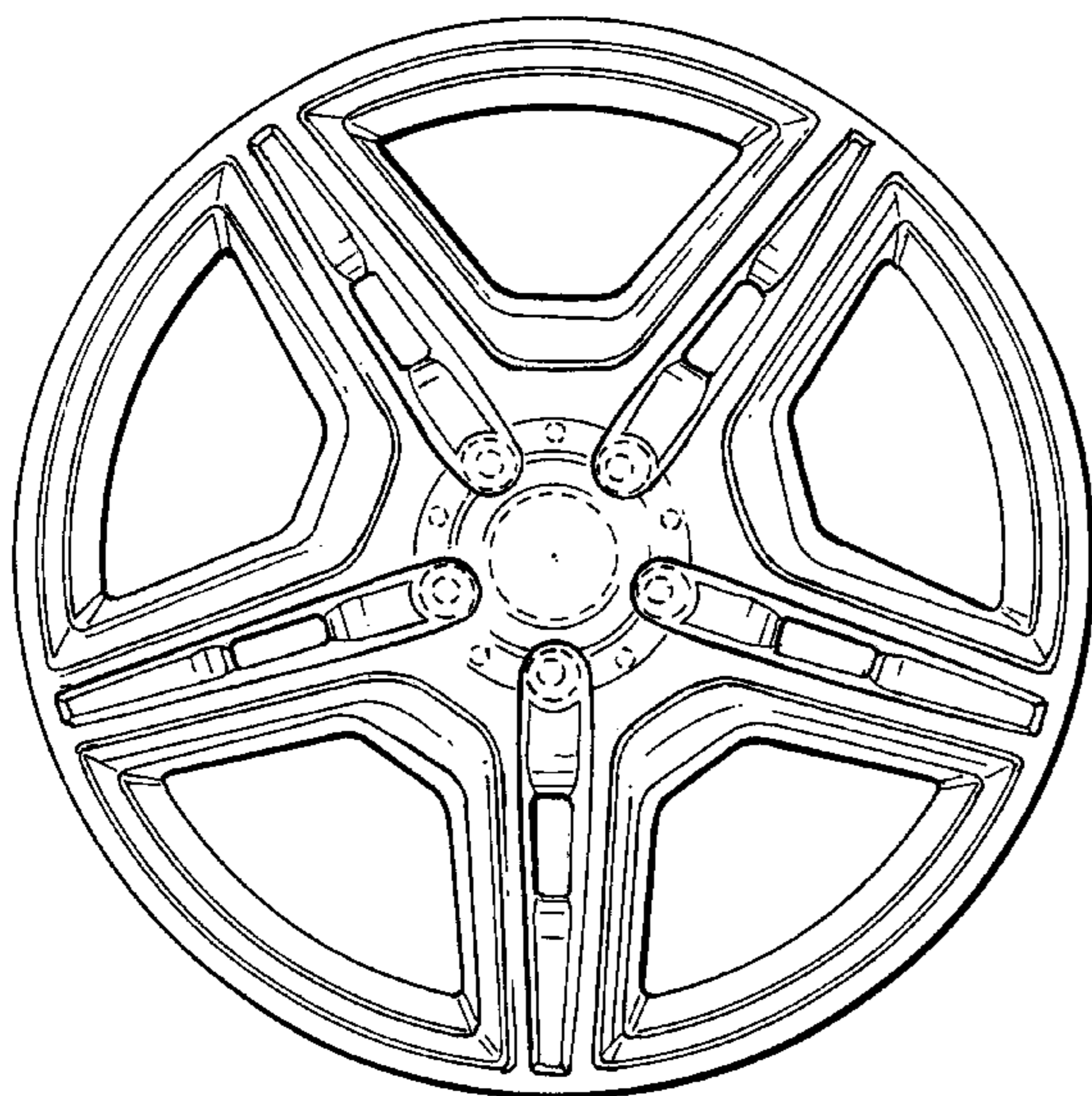

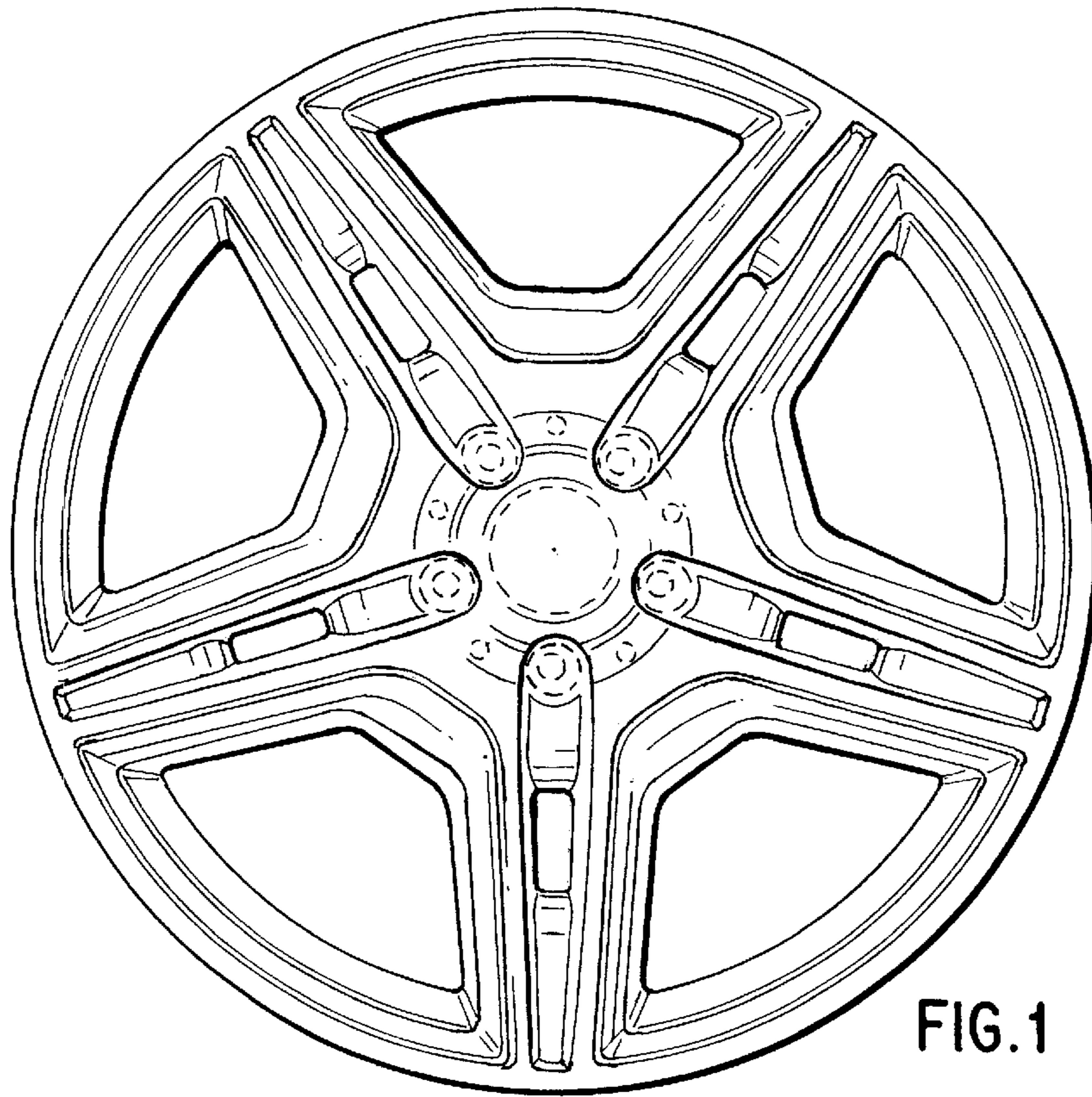

FIG. 1

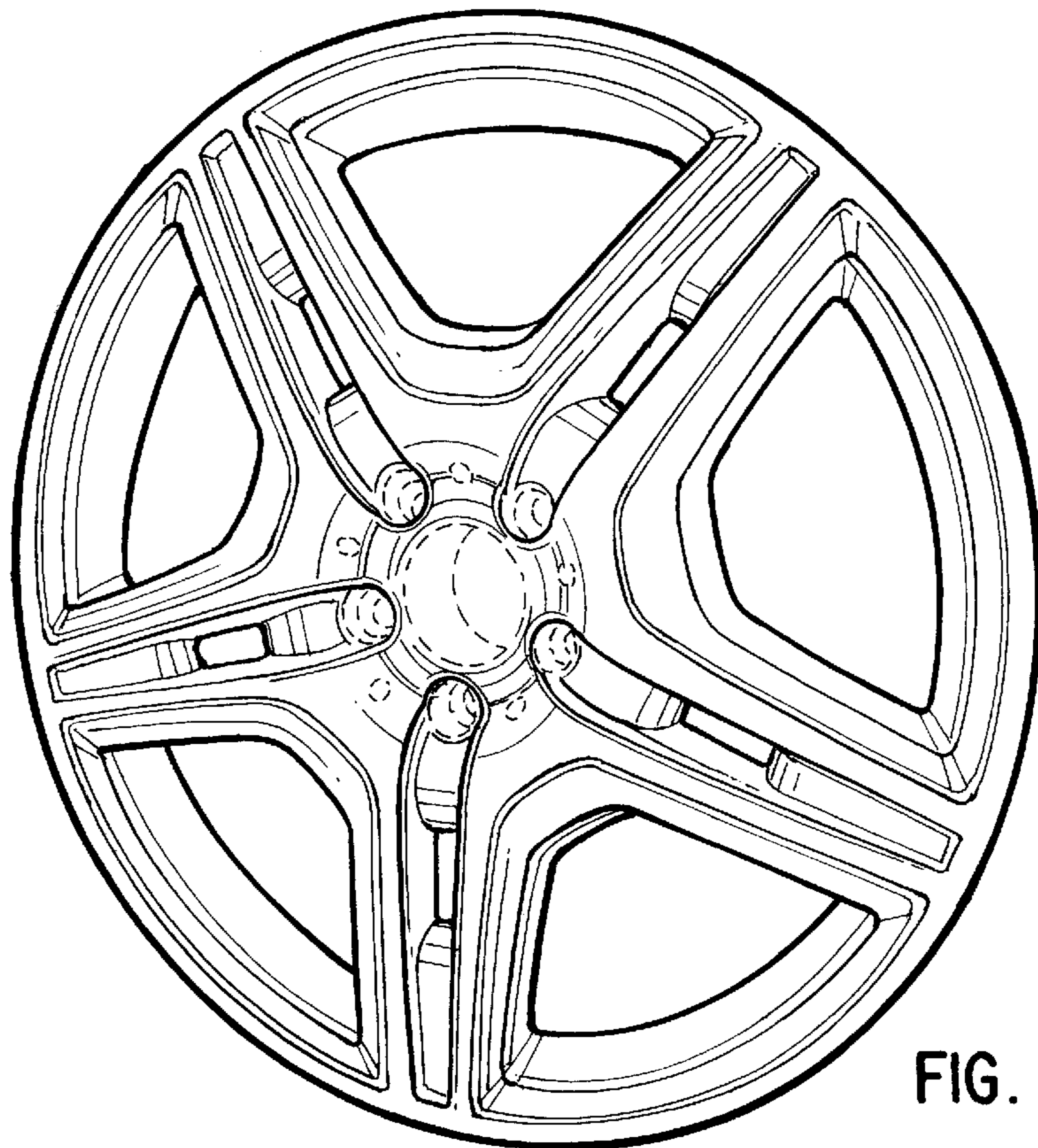

FIG. 2

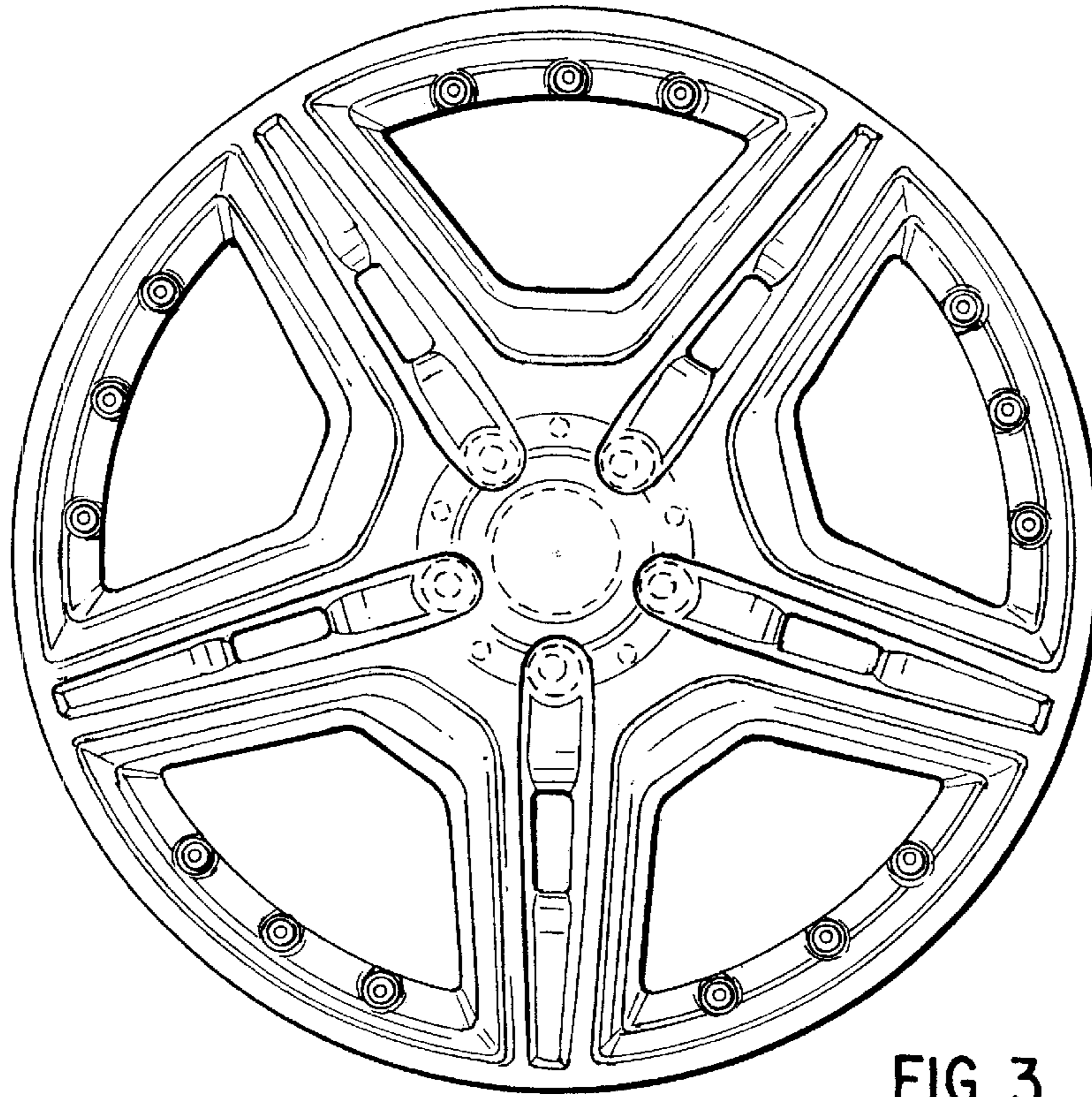

FIG. 3

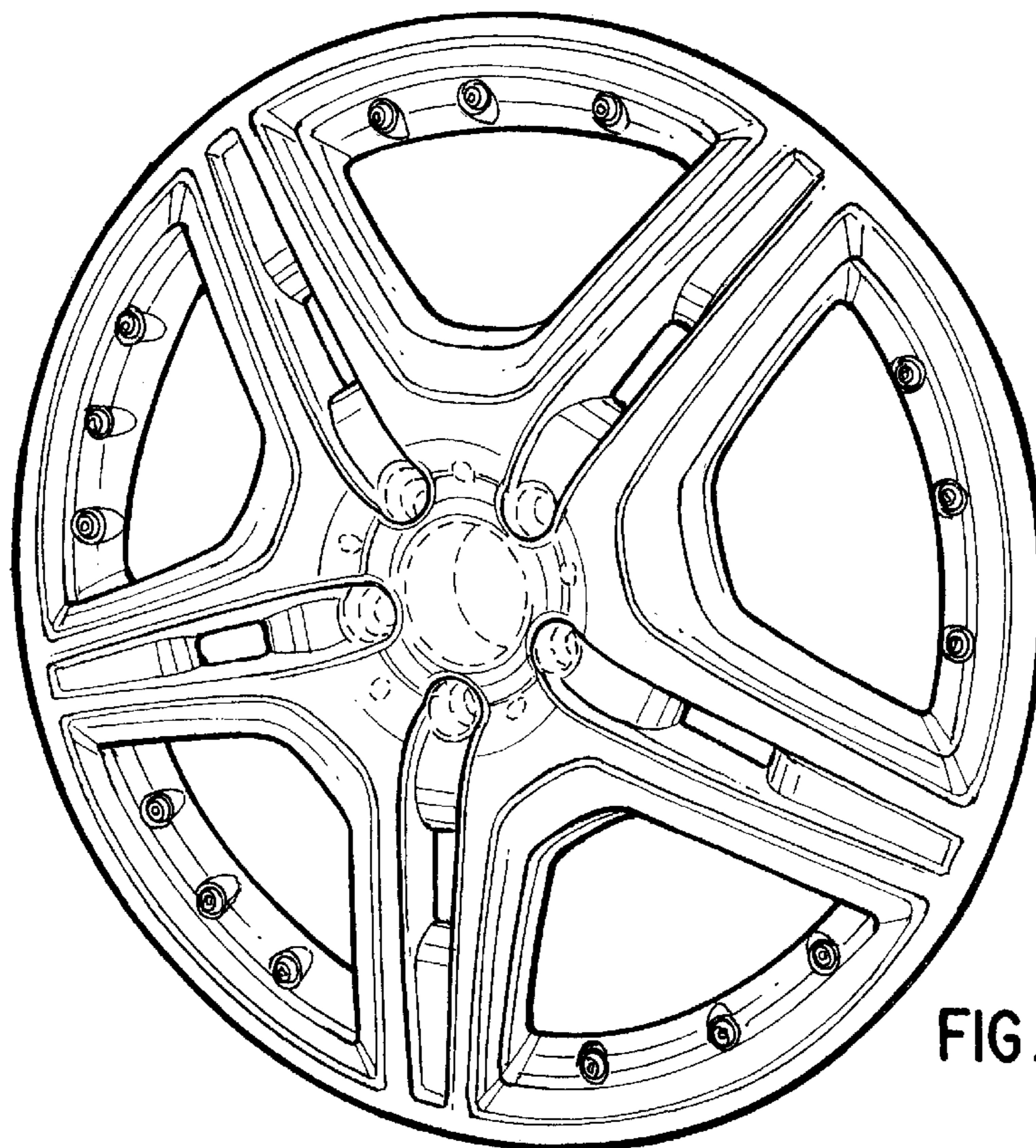

FIG. 4